

Hybrid Micro Genetic Algorithm Assisted Optimum Detector for Multi-Carrier Systems

Mahmoud A. M. Albreem¹, SPK Babu², M F M Salleh³

Department of Electronics and Communication Engineering, College of Engineering, A'Sharqiyah University, 400 Ibra, Oman

Article Info

Article history:

Received Aug 9, 2017

Revised Nov 20, 2017

Accepted Dec 28, 2017

Keywords:

Genetic Algorithms
Maximum Likelihood
OFDM

ABSTRACT (10 PT)

A low-complexity detection scheme, which consists of a Hybrid Micro Genetic Algorithm (Hybrid- μ GA), is proposed for Orthogonal Frequency Division Multiplexing (OFDM) systems. In the absence of orthogonality, intercarrier-interference (ICI) occurs because a signal from one subcarrier causes interference to others. In several environment, the OFDM signal reflections from a far obstacle generate inter-block-interference (IBI) due to long time delays. To avoid these unpleasant effects of IBI and ICI in OFDM system, a Hybrid- μ GA detection algorithm is proposed. The proposed detector combines the conventional one-Tap equalizer and the Micro Genetic Algorithm (μ GA) search engine. The output of one-Tap equalizer is considered as the input to μ GA search engine. Therefore, the μ GA starts with some knowledge rather than blindly to speed up the search. Theoretical analysis and simulation results show that the proposed detection Hybrid- μ GA scheme substantially improves the performance of OFDM systems. Moreover, its complexity is 10 times lower than the conventional GA.

*Copyright © 2018 Institute of Advanced Engineering and Science.
All rights reserved.*

Corresponding Author:

Mahmoud A. M. Albreem,
Department of Electronics and Communication Engineering, College of Engineering,
A'Sharqiyah University, 400 Ibra,
Oman
Email: mahmoud.albreem@asu.edu.om

1. INTRODUCTION

Orthogonal Frequency Division Multiplexing (OFDM) offers high data rate transmission for wireless applications. Therefore, it has been chosen for Digital audio/Video broadcasting (DAB/DVB), high Speed digital subscribers line (DSL), WMAN, HiperLAN systems, Long Term Evolution (LTE), Long Term Evolution-Advanced (LTE-A), etc [1]. However, OFDM transforms the frequency selective fading channel condition into a set of narrow flat fading channels, thereby reducing the effects of Inter Symbol Interference (ISI) [1].

Minimum Mean Square Estimation (MMSE) based Zero-Forcing (ZF) equalizer is a low complexity suboptimal solution but this technique reduces ICI with some limitations. Whenever the normalized Doppler frequency becomes large, the noise enhancement and ICI are prevailing. Therefore, MMSE becomes unsuitable [2].

Maximum likelihood detection (MLD) is the optimal detection technique. The MLD has a high computational complexity, especially for a large block data size. Therefore, other methods such as Viterbi Algorithm (VA), iterative decoding [3 - 9], and Genetic Algorithms (GA) [10-11] had been proposed to assist the detection process.

The applications of GA algorithms for multiple-input-multiple-output (MIMO) system are presented in [7 , 10]. The GA algorithm is also used in Multi-User-Detection (MUD), and OFDM along with a Minimum Mean Square Error (MMSE) detector.

The work in [11, 12] presents a single antenna OFDM system using GA. Work in [10] presents the adaptive subcarrier and bit allocation scheme to maximize the sum data rate for multiuser OFDM systems using GA. Different initial condition to accelerate convergence time of GA is used without sacrificing the performance of the system. Meanwhile, the work in [12] presents the use of GA to solve the problem of the maximum-likelihood estimation of OFDM system in the presence of nonlinear distortion. In [13], a detection scheme consisting a sphere decoder and parallel interference cancellation (PIC) equalizer achieved a relatively lower complexity than other detectors. In [14], an efficient lattice sphere decoding (LSD) technique has been proposed for multi-carrier systems. The proposed detection technique combines the LSD with two regularization methods. In [15], an implementation of receivers for spatial multiplexing MIMO-OFDM system is considered. The results provide a solid basis for systematic complexity-performance tradeoff of different detection algorithms for application in the evolving next generation cellular access standard.

The main objective of this paper is to propose an efficient Hybrid- μ GA detection scheme to achieve a good balance between complexity and performance. The proposed detection scheme is suitable for the systems suffered ICI and IBI. However, LTE system depends on MIMO-OFDM structure, the proposed detection technique is suitable and applicable for LTE and LTE-A systems.

This paper is organized as follows: Section 2 is a description of the OFDM system. Section 3 presents the GA and Micro-GA Based MLBD. Section 4 presents the proposed detection algorithm. Section 5 presents a mathematical analysis of the system performance. Section 6 presents the results and discussion, and Section 7 concludes the paper.

2. ORTHOGONAL FREQUENCY DIVISION MULTIPLEXING

Figure.1 shows the block diagram of the proposed OFDM system. A continuous binary information bits are truncated into blocks of data. The zero bits are added to make each block to be of size (N). Then, the bits of each block are mapped using any modulation scheme. The mapped data are converted to parallel symbols and should be transmitted to an inverse Fast Fourier Transform (iFFT). This process modulates each symbol by a carrier (total N carriers) in time domain.

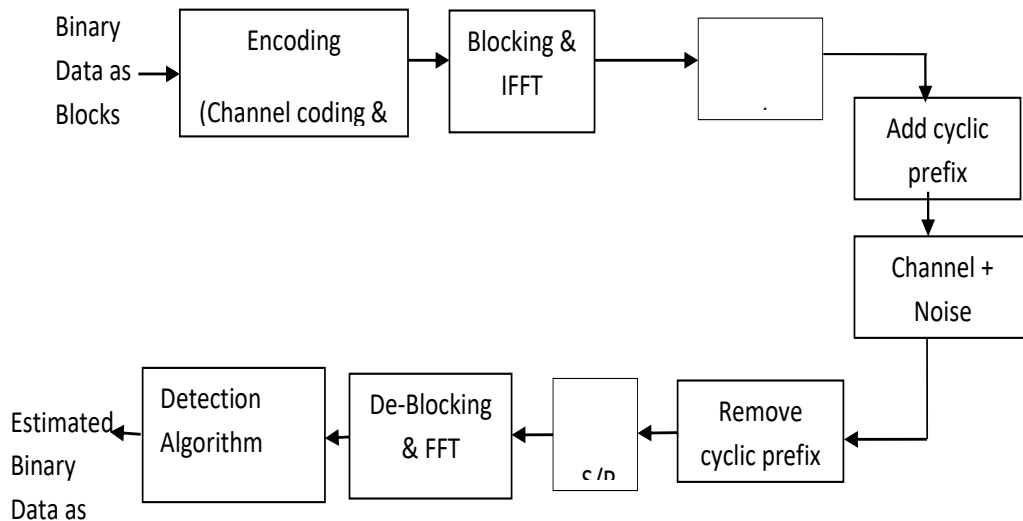

Figure. 1 Block Diagram of the Proposed OFDM System

In order to avoid IBI, a copy of the last few symbols (length greater than or equal to the order of channel) of each block is concatenated to the block. This is called the cyclic prefix (CP) which is discarded at the receiver. The addition of CP makes the linear convolution to be a circular convolution which producing a diagonal channel matrix at the receiver [17].

At the receiver, CP should be removed and the block data are converted to parallel symbols. Thereafter, they are fed to the Fast Fourier Transform (FFT). The data block are converted to serial data and

Multiplied by the complex conjugate of the channel frequency response via equalization process. Then the serial data are fed to a detector and the bits are recovered.

Suppose C_i be the OFDM block to be transmitted through a fading channel $h(n)$ of length L defined as

$$C_i = [c_i(0), c_i(1), \dots, c_i(N-1)]^T \tag{1}$$

$$h(n) = [h(0), h(1), \dots, h(L-1)] \tag{2}$$

and

$$H(n) = \sum_{l=0}^{L-1} h(l)e^{-j2\pi nl/N} \tag{3}$$

$H(n)$ is the channel frequency response of the n th sub carrier [18]. The $H(n)$ term is the FFT grid of the channel with each coefficient reflecting a set of narrow flat channel. This block consists of the BPSK, QPSK, or QAM symbols. It also consists of zero symbols that form the virtual channels to prevent the power leaking to the nearby channels [17]. The iFFT is performed by multiplying the C_i with a matrix F as given as

$$s_i = F^H C_i \tag{4}$$

where H represents a Hermitian transpose. The elements of F matrix are given as

$$[F]_{n,k} = \frac{1}{N} \exp\left(\frac{-j2\pi nk}{N}\right), \text{ for } 0 \leq n, k \leq N-1 \tag{5}$$

After adding N_g cyclic prefix, the transmitted signal becomes

$$S_{i_cp} = T_{cp} S_i \tag{6}$$

Where

$$T_{cp} = \begin{bmatrix} P_{N_g \times N} \\ I_N \end{bmatrix} \tag{7}$$

where I_N is represented by the $N \times N$ identity matrix and $P_{N_g \times N}$ is $N_g \times N$ matrix collecting the last N_g rows as CP. Without considering the noise, the received signal is defined as

$$r_{i_cp} = B^l S_{i_cp} + B^u S_{i-1_cp} \tag{8}$$

Where

$$B^l = \begin{bmatrix} 0 & \dots & h(1) & h(2) & \dots & h(L-1) \\ 0 & \dots & 0 & h(1) & \dots & h(L-2) \\ \vdots & \vdots & \vdots & \vdots & \ddots & \vdots \\ 0 & \dots & \dots & \dots & 0 & h(1) \\ 0 & \dots & \dots & \dots & \dots & 0 \\ \vdots & \vdots & \vdots & \vdots & \vdots & \vdots \\ 0 & \dots & \dots & \dots & \dots & 0 \end{bmatrix} \tag{9}$$

And

$$B = \begin{bmatrix} h(0) & 0 & 0 & \dots & 0 \\ h(1) & h(0) & 0 & \dots & 0 \\ h(2) & h(1) & h(0) & \dots & 0 \\ \vdots & \vdots & \vdots & \ddots & \vdots \\ h(L-1) & h(L-2) & h(L-3) & \dots & 0 \\ 0 & h(L-1) & h(L-2) & \dots & 0 \\ \vdots & \vdots & \vdots & \ddots & \vdots \\ 0 & 0 & \dots & 0 & h(0) \end{bmatrix} \tag{10}$$

The second term in Equation 8 represents the IBI component [14, 18], which can be removed by multiplying the term with Rcp. Therefore, the received signal is given as

$$r_i = R_{cp} r_{i_cp} = B^c F^H C_i \tag{11}$$

where $B^c = R_{cp} B^H T_{cp}$ is a circulant matrix whose first column is given by $[h^T \ 0_{N-L}^T]^T$. The received signal r_i is converted from parallel to serial and fed to the FFT unit can be expressed as

$$R_i = F B F^H C_i = D_d C_i \tag{12}$$

FBFH is diagonal matrix due to the diagonalization property of the circulant matrix [14]. The transmitted signal can be recovered by Equation 13.

$$\hat{C}_i = D_d^{-1} R_i \tag{13}$$

Equation 12 can be represented in a scalar form as

$$R_i(n) = H(n) C_i(n), \quad 0 \leq n \leq N-1 \tag{14}$$

Since D_d is a diagonal matrix, Equation 14 can be re-written as

$$\hat{C}_i(n) = \frac{R_i(n)}{H(n)}, \quad 0 \leq n \leq N-1 \tag{15}$$

Equation 15 shows that each element of the received vector is multiplied by single element (one Tap) of $1/H(n)$. The system works well in absence of noise and for channels without deep fades (spectral nulls). However, when the channels exhibit spectral nulls, this inversion process leads to high BER [18].

3. IMPLEMENTATION METHODS FOR GA PARAMETERS

In GA, many parameters should be taken into consideration such as coding, objective function evaluation, search process, and stopping criteria of GA. In this research, a binary GA (BGA) is used. Therefore, when the search process is completed, the solution should be given by the GA in a binary form.

3.1 Coding of Solution Space

This section presents the coding part of GA solution space. Table I illustrates the transmission and detection of message blocks of size 4 through the ISI affected channel using a MLD where all possible solutions are presented.

Table I: Coding of Solution Space for a Message Block of Size 4 in Binary Format

Block No.	Message Block	Message Block
1	-1 -1 -1 -1	0 0 0 0
2	-1 -1 -1 1	0 0 0 1
3	-1 -1 1 -1	0 0 1 0
4	-1 -1 1 1	0 0 1 1
5	-1 1 -1 -1	0 1 0 0
6	-1 1 -1 1	0 1 0 1
7	-1 1 1 -1	0 1 1 0
8	-1 1 1 1	0 1 1 1
9	1 -1 -1 -1	1 0 0 0
10	1 -1 -1 1	1 0 0 1
11	1 -1 1 -1	1 0 1 0
12	1 -1 1 1	1 0 1 1
13	1 1 -1 -1	1 1 0 0
14	1 1 -1 1	1 1 0 1
15	1 1 1 -1	1 1 1 0
16	1 1 1 1	1 1 1 1

3.2 Objective Function

Figure. 2 shows the objective function for each chromosome that represents the possible transmitted message in the GA based SC-BDTS. The objective function can be expressed as

$$e_{SSE} = \sum |R_n - S_i H| \quad (16)$$

where e_{SSE} , R, S, and H are the Euclidean distance, the received block, transmitted block, and channel matrix, respectively. For a message block size of 4, there are 16 possible message blocks or solutions. If the transmitted message block is the row 15th (See Table I) for the received vector R, the Equation 16 (objective function) is evaluated for all possible message blocks S_i . For the noise free condition, the objective function value is zero for the 15th block, and the other blocks result in a non-zero value for the evaluation of Equation 16. Figure 2 shows the objective functions presented in Equation 16 when the 15th message block ([1 1 1 -1]) is transmitted through normalized channel impulse response [0.4082 0.8165 0.4082] [19]. If a gradient based search technique is used, there is a possibility that the search technique will end up in some local minima. In this case the message blocks 7, 11, 13, and 16 are such local minima, which are closer to zero (the global optimum) and competitors for the 15th block.

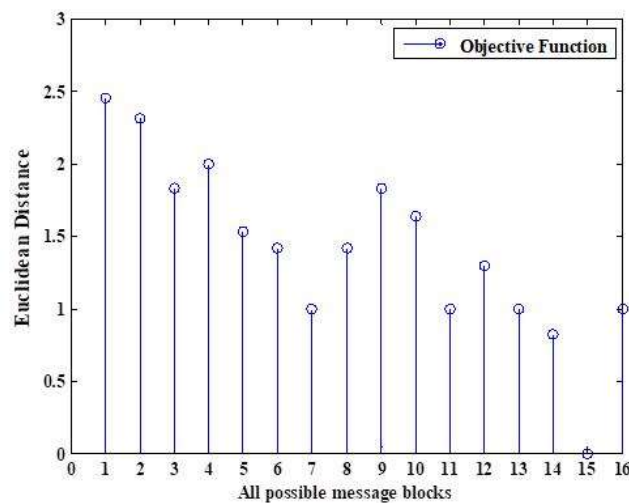

Figure 2. Euclidean Distances of All Possible Blocks for Channel [0.4082 0.8165 0.4082]

3.3 Stopping Criteria

The GA process starts with a set of solutions or training data and ends with a set of solutions. The best among the solutions at the end of the run is taken as the global optimum, which is the transmitted block, as in this case. The convergence of the GA for the channels taken into consideration differs with respect to the distortion. This is due to increase in number of competitors (local minima) or equivalent decreases in the objective function value of the competitors. In this case, the GA takes more time to converge the global optimum, which is the transmitted block. The proposed GA based detector system is time sensitive. The stopping criterion considers the use of the maximum generations of the GA for a particular Initial population to converge. The maximum generations for the GA based detectors for the BDTS under a particular channel are found in advance by the trial and error method. After checking the GA convergence on 106 blocks, SNR value is increased. Even though this procedure is time consuming, it is done in offline and the result values are stored. Once the channel parameters like impulse response and frequency response are known, the Initial population size and maximum generations, which vary for different channel characteristics, are set. Other parameters like Crossover, Mutation and Selection are found from parameter tuning.

Figure 3 is done offline. The procedure shown is to determine the number of generations required for GA based detectors to perform equally with the Exhaustive search technique, which is the optimum system. Similarly, the size of Initial population is fixed and generations are varied. A data block is generated and convolved with the Channel Impulse Response (CIR) and noise is added for the defined SNR value. The received data block is sent to the Exhaustive search and GA based MLBD method for detection. If the results are the same; the procedure is repeated for 106 times, which is the maximum number of blocks. This value (number of experiments) of 106 is taken to ascertain the working of the system. If the results are different, the generations are increased in tens. The increment ten is chosen because it is not too small or too big to miss intermediate value.

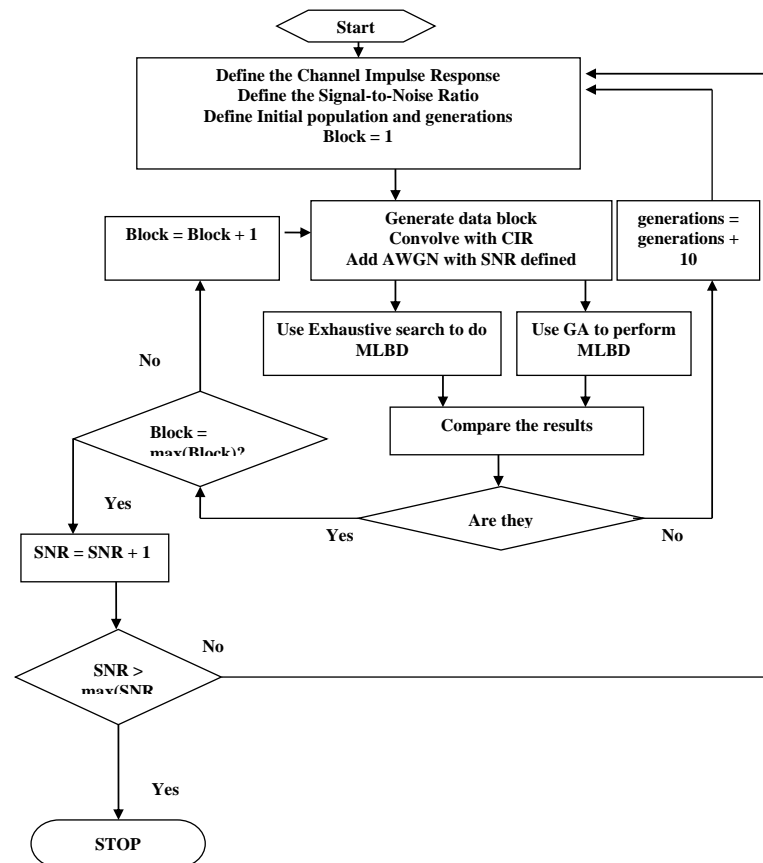

Figure. 3 Procedures to Find the Maximum Generations for Convergence

4. DETECTION SCHEME

This section presents the maximum likelihood detection scheme, followed by the proposed hybrid- μ GA based MLD

4.1. Maximum Likelihood Detection

The MLD problem is formulated below where the received block is given as

$$R_i(n) = H(n)C_i(n) + w(n) \quad (17)$$

where $w(n)$ is the additive white Gaussian noise (AWGN) with zero mean and variance $E\{|w(n)|^2\} = \sigma_w^2$. The MLD compares all the possible C_i with the received signal defined in Eq.17 based on the Euclidean distance as shown in Equation 18. The C_i that has the lowest Euclidean distance value is chosen as the most probable transmitted block.

$$e = |R - HC_i| \quad (18)$$

In this estimation, the block involves the CP term which has sufficient statistic about the signal. For a symbol length of N , the CP length of N_g and channel length of L , the received vector R have length l is given as

$$l = \begin{cases} N + N_g; & \text{if } L \leq N_g \\ N + L - 1; & \text{if } L > N_g \end{cases} \quad (19)$$

IBI occurs when l is greater than $N + N_g$. In this situation, the detector does not take into consideration the Inter-Block-Interference (IBI) and the receiver should wait for the next block and uses the channel impulse response (CIR) shortening procedure.

4.2. Hybrid Micro GA Based MLD

Figure 4 shows the block diagram of the proposed detection algorithm. Maximum likelihood block detection (MLBD) for the problem is handled using the Hybrid- μ GA based detector. This detector combines the conventional one-Tap equalizer with the μ GA search engine. The output of the one-Tap equalizer after threshold detection is suboptimal and used as the starting point of the μ GA search engine. By this arrangement, the μ GA starts with some knowledge rather blindly. This procedure speeds up the search process thereby reducing the computational load by reducing the initial population. Table II shows a comparison between the proposed Hybrid- μ GA and conventional GA in term of initial population variations

Table II: Initial Population Variations

SNR (dB) Method	0	2	4	6	8	10	12	14
Conventional GA	1600	1400	1200	1000	800	700	600	500
Hybrid μ GA	700	700	600	600	500	500	500	400

The population size of 5 is used in this work. The GA parameters used are two point crossover, stochastic uniform selection and mutation rate of zero. In the algorithm, the first generation of the μ GA process is altered by forcing the best individual to be the output of the one-Tap equalizer. The Hybrid μ GA based MLBD algorithm is given as:

- Step 1: Generate random population of size 4.
- Step 2: Add the detected block from BLE to the population generated so that the total population is 5.
- Step 2: Fitness function is evaluated for the chromosomes generated in step 1, 2 and best individual is taken.
- Step 3: The best individual is taken for the next generation.
- Step 4: The selection is made on five chromosomes.
- Step 5: Do crossover at rate equal to 1.

Step 6: Check for convergence (In this case Maximum generations) and if it is not achieved retain the best string and generate randomly another 4 chromosomes and go to step 2.
 Step 7: Stop.

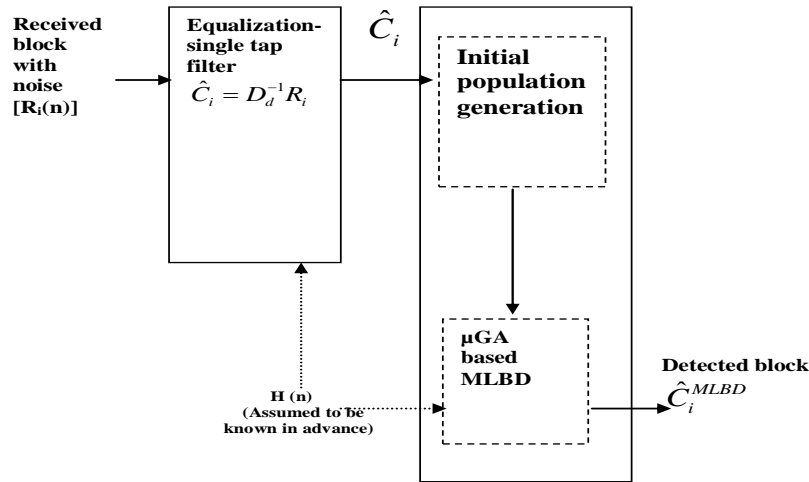

Figure. 4 Hybrid μ GA based MLBD for OFDM

4.3. Hybrid Micro GA Based MLBD

Figure 5 shows the GA based ML detector for the OFDM system. In this system, the detection part of the OFDM symbol is performed by the GA based MLBD. The GA based MLBD compares the received block with all possible (here it is 2^m , where m is the size of the OFDM symbol) symbols. Again it has to be noted that the receiver has a prior knowledge about the channel impulse response (CIR), and perfect synchronization is also assumed between transmitter and receiver

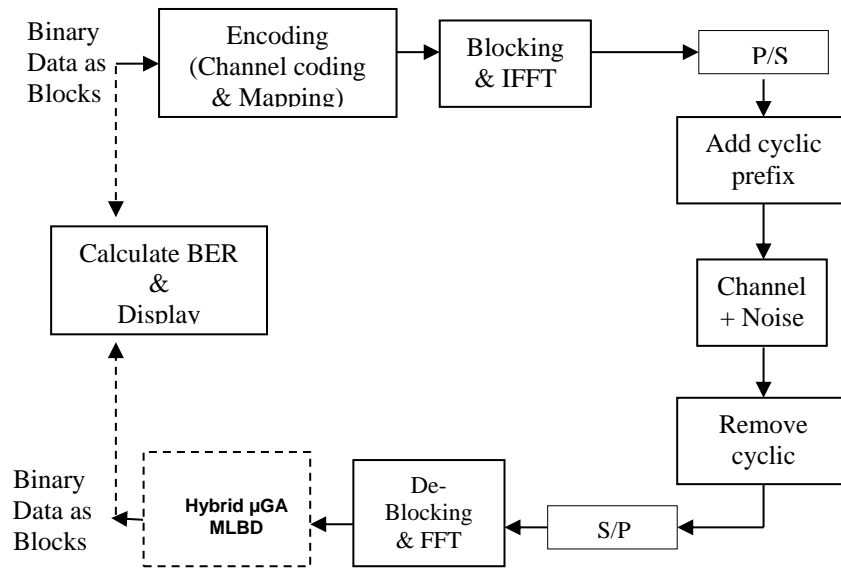

Figure. 5 General Block Diagram of A GA based MLBD for An OFDM System

The GA parameters Crossover, Mutation, Selection, are defined. For example, one can define what type of Crossover (Single point, Two point, or Multi point) is used. The Initial population parameter is changed, as it depends on the SNR value. The Initial population is chosen as high or low SNR, or vice versa. The SNR value is incrementally changed after each iteration. The flow chart of the Hybrid- μ GA system is shown in Figure 6, where the μ GA detector is used instead of the GA detector. The hybridization part is

shown by the dotted line. The received block is sent to block linear equalizer (BLE). The output of the BLE is taken as one of the five Initial populations, and it is the input to the μ GA. The incorporation of μ GA instead of GA has changed the GA's parameter definition. For Micro-GA it is the number of generations, which is varied for different SNR value, as the Initial population is always fixed.

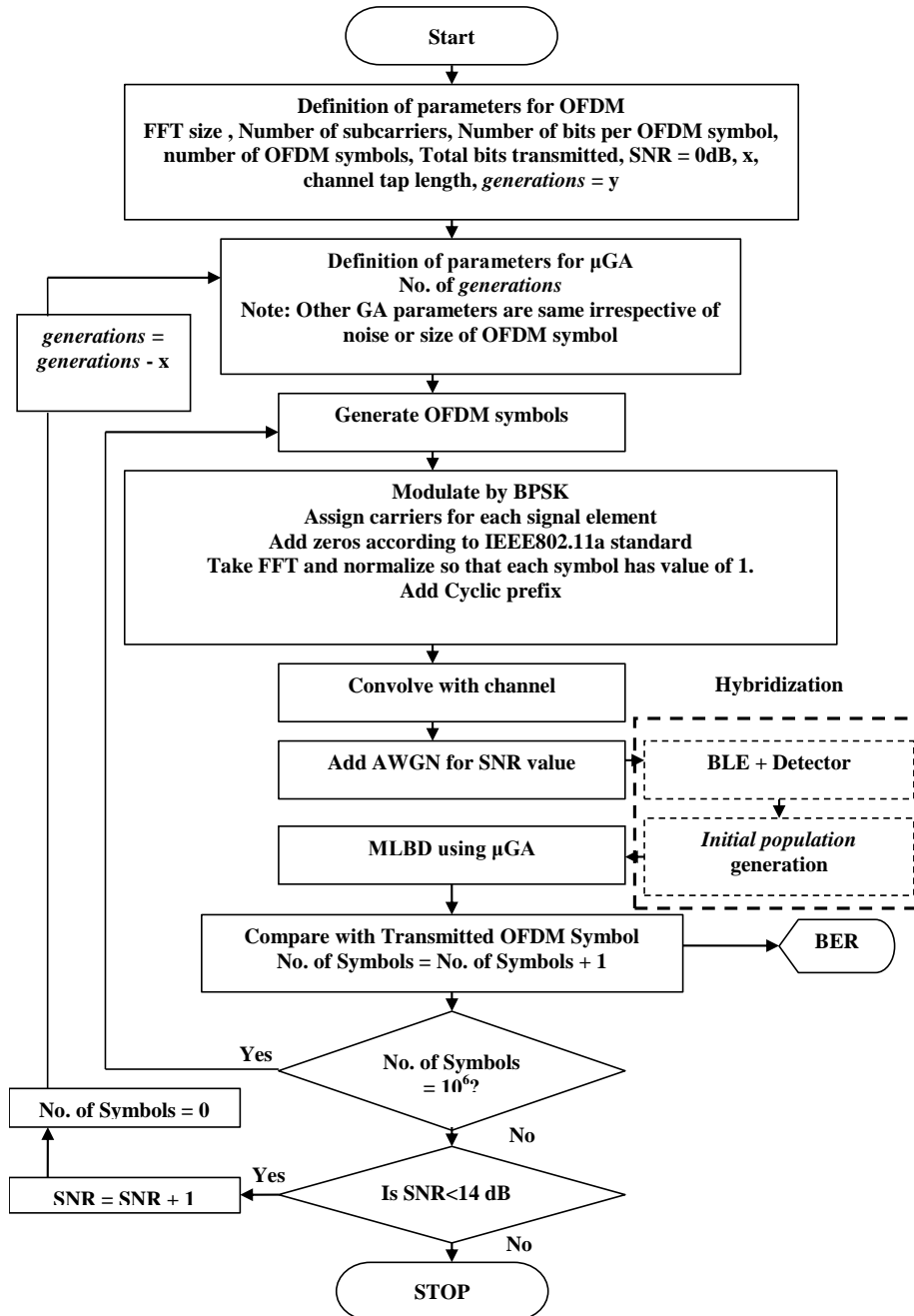

Figure. 6 Methodology of Hybrid- μ GA based MLBD for Multi-Carrier (MC) system

5. PERFORMANCE ANALYSIS

An error E_{ik} occurs when message block S_i is transmitted and message block S_k is received (S_i and S_k are any two possibility, $2m$ message blocks for block size of “ m ”) [16]. Error E_{ik} can be expressed as

$$E_{ik} = \{R : d(R, S_k Y) < d(R, S_i Y)\} \tag{20}$$

where $R = HiY + N$ and $d(R, SiH)$ is the distance between the received vector R from SiH . Therefore, error occurs when a block Si is detected as Sk . This occurs when the received block Si lies beyond the perpendicular bisector of the line $d_{ik} = \|SkH - SiH\|$. For any message block, probability of block error is given as

$$p[E_{ik}] = \int_{\frac{d_{ik}}{2}}^{\infty} \frac{1}{\sqrt{\pi N_o}} \exp\left(-\frac{\eta^2}{N_o}\right) d\eta \tag{21}$$

Equation 21 is a standard Gaussian integral and can be expressed as Q function which is the integral of the tail of the unit variance zero mean of a Gaussian density function [11, 20]. Therefore, Equation 21 can be re-written as

$$p[E_{ik}] = Q\left(\frac{d_{ik}}{2\sigma}\right) \tag{22}$$

Equation 22 is the general expression of the probability of block error ($p[E_{ik}]$) for message block Si transmitted and Sk detected. For all other error events by the possible message blocks including Sk gives an upper-bound on the probability of Block Error as

$$p(E / S_i) = p\left[\bigcup_{k=1, k \neq i}^{2^m} E_{ik}\right] \leq \sum_{k=1, k \neq i}^{2^m} p[E_{ik}] \tag{23}$$

Upon substitution of Equation 23 in the upper bound we get

$$p_{BLER} \leq \sum_{k=1, k \neq i}^{2^m} Q\left(\frac{d_{ik}}{2\sigma}\right) \tag{24}$$

This is the upper bound on block error probability for a message block Si being transmitted. The Q function is a very steep function and the above sum is dominated by small arguments of d_{ik} which is d_{min} or twice the minimum of distances to decision boundary

$$d_{min} \leq d_{ik} \text{ and } Q\left(\frac{d_{min}}{2\sigma}\right) \geq Q\left(\frac{d_{ik}}{2\sigma}\right) \tag{25}$$

The upper bound can be approximated as

$$p_{BLER} \leq (2^m - 1)Q\left(\frac{d_{min}}{2\sigma}\right) \tag{26}$$

A lower limit can be obtained by limiting to the message blocks that have minimum distance d_{min} . The total number of such blocks is given as N_{min} . When limiting to the nearest message blocks, the lower bound of the block error probability is given by;

$$p_{BLER} \geq N_{min}Q\left(\frac{d_{min}}{2\sigma}\right) \tag{28}$$

Then, the relation between the probability of block error (PBLER) and probability of bit error (PBER) can be given as

$$P_{BER} = 1 - (1 - P_{BLER})^m \quad (29)$$

If the (P_{BER}) is small; its higher powers can be neglected and, therefore, Equation 29 can be written as

$$P_{BER} = \frac{1}{m} P_{BLER} \quad (30)$$

Therefore, the probability of bit error (P_{BER}) can be simplified as

$$P_{BER} \geq \frac{N_{Min}}{m} Q\left(\frac{d_{min}}{2\sigma}\right) \quad (31)$$

However, the simulations are performed in this research to get a low BER using the proposed hybrid- μ GA detection scheme.

6. RESULTS

The BER performance of the ZF equalizer, GA based MLBD, μ GA based MLBD, sphere detection, and Hybrid- μ GA based MLBD are compared in this subsection. Random OFDM blocks have been transmitted for 106 times.

Figure.7 compares the performance of the proposed scheme Hybrid- μ GA detector with the ML detection using exhaustive detection and sphere detection technique proposed in [14]. It is evident that GA based system has the same performance as the optimum ML based detector.

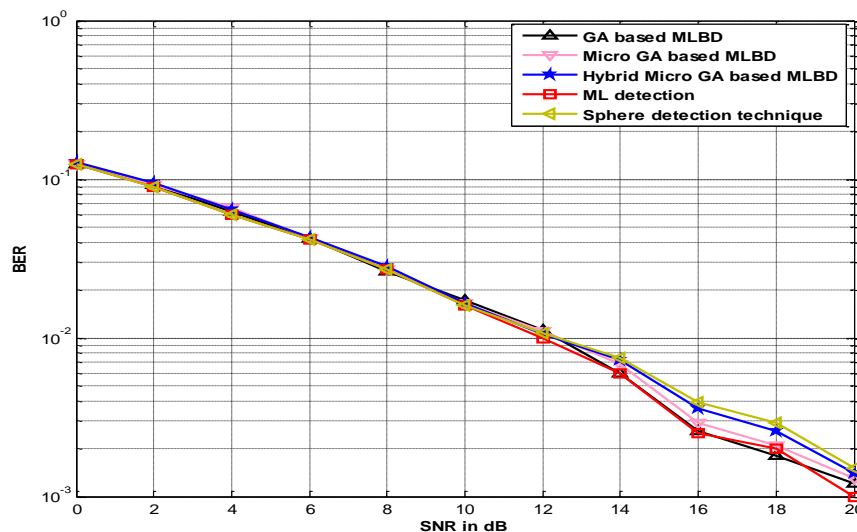

Figure. 7 Bit Error Rate Performance of GA based Detector (3-Tap Channel)

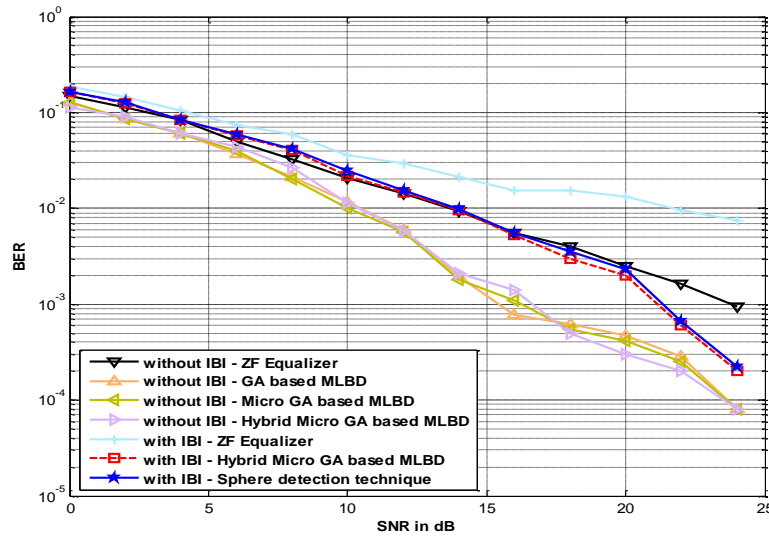

Figure. 8 Bit Error Rate Performance of GA based Detectors (10-Tap Channel)

Figure 8 shows the performance comparison of various GA based detectors for channel with long delay spread. It's shown that the proposed Hybrid-μGA detector outperforms the conventional GA based detectors. Figure 8 also presents the extreme case of having IBI in OFDM system where the number of CP is reduced to three symbols. The performance of the proposed Hybrid-μGA detector performs well at SNR 20 and above as compared to the one-Tap conventional equalizer which exhibits poor performance. It is also clear that the proposed Hybrid-μGA detector outperform the sphere detector proposed in [14].

In literature, the number of objective function evaluation is used for computational complexity measurement for GA based algorithm. Objective function is the product of the population size and number of generations. There are other various parameters of Hybrid-μGA process like selection, mutation, crossover, population size, and generations that can be tuned by trial and error basis to match the BER performance of the Exhaustive search based ML detector (optimum detector). The number of generations needed for convergence is found by similar way and stored for each SNR value.

Figure. 9 shows the complexity analysis of Exhaustive search, conventional GA, μGA and Hybrid μGA. For SNR of 20 dB and 10 Tap Rayleigh fading channel, it is clear that the Hybrid μGA based algorithm detector requires very few objective function evaluations as compared to conventional GA based approaches. This figure also shows that the proposed Hybrid-μGA based detector proposed in this work reduces the computational complexity of ordinary μGA by half.

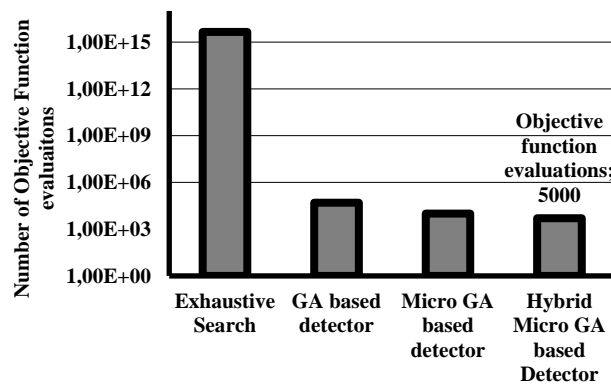

Figure 9. Complexity Analysis of Proposed Detector in Terms of Objective Function Evaluation

Complexity analysis, it is apparent that the proposed detection algorithm achieved a good balance between complexity and performance.0

7. CONCLUSION

A low complexity Hybrid- μ GA scheme is investigated for the OFDM system. The Hybrid technique speeds up the search process of the μ GA. The BER and computational complexity of the proposed detector is also analyzed. The complexity of the detector with respect to the conventional GA detector found in literature is reduced by 10 times. Thus, the proposed detection scheme is an attractive candidate for OFDM signal detection.

ACKNOWLEDGEMENTS

The authors would like to thank the University Malaysia Perlis (UniMAP), University Science Malaysia (USM), and Ministry of Higher Education “Malaysia” for their financial supports.

REFERENCES

- [1] Mahmoud A. M. Albreem (2015). An Efficient Lattice Sphere Decoding Technique for Multi-Carrier Systems. *Wireless Personal Communications*, 82(3), 1825-1831.
- [2] Dogan, H., Panayircı, E., & Vincent Poor, H., (2009). OFDM Receiver Design In The Presence Of High Mobility Fading Channels. *Proc NEWCOM - ACoRN Joint Workshop*, Barcelona, Spain.
- [3] Quadeer, A. A., Al-Naffouri, T. Y., & Shadaydeh, M., (2008). Iterative Blind Data Detection in Constant Modulus OFDM Systems. *Proc. 16th European Signal Processing Conference (EUSIPCO08)*, Lausanne, Switzerland.
- [4] Tellado, J., Loo, L., & Cioffi, J., (2003). Maximum-likelihood detection of nonlinearly distorted multicarrier symbols by iterative decoding. *IEEE Transactions on Communications*, 51(2), 218–227.
- [5] Liang, Y., Shu, F., Berber, S., Zhang, Q., & Liu, Z., (2009). Low-complexity sphere decoding for detection of OFDM systems in doubly-selective fading channels. *Electronic Letters*, 45(15), 797-798.
- [6] Cui, T., & Tellambura, C., (2004). Joint Channel Estimation and Data Detection for OFDM Systems via Sphere Decoding. *Proceedings of the Global Telecommunications Conference (IEEE GLOBECOM-04)*, 6, 3656 – 3660.
- [7] Jiang, M., & Hanzo, L., (2004). Genetically Enhanced TCM Assisted MMSE Multi-user Detection for SDMA-OFDM. *Proc. IEEE Conference on Vehicular Technology*, 3, 1954-1958.
- [8] Mahmoud A. M. Albreem, M. F. M. Salleh, and SPK. Babu, (2011). Reduced Complexity Optimum Detector for Block Data Transmission Systems using Lattice Sphere Decoding Technique. *IEICE Electron. Express*, 8(9), 644-649.
- [9] Mahmoud A. M. Albreem, and M. F. M. Salleh (2014). Lattice Sphere Decoding Technique for Block Data Transmission Systems with Special Channel Matrices. *Wireless Personal Communications*, vol. 79, issue: 1, pp. 265-277.
- [10] M. Jiang, J. Akhtman, and L. Hanzo (2007). Soft-Information Assisted Near-Optimum Nonlinear Detection for BLAST-type Space Division Multiplexing OFDM Systems. *IEEE Transactions on Wireless Communications*, vol. 6, no. 4., 1230-1234.
- [11] Ozbek, B., & Ruyet, D. L., (2008). Sum-rate Maximized Adaptive Subcarrier and Bit Allocation for Multiuser OFDM Systems with Genetic Algorithm. *Proc. 16th IEEE Conference on Signal Processing, Communication and Applications (SIU 2008)*, 1-4.
- [12] Sacchi, C., (2007). Genetic-Algorithm assisted Maximum-Likelihood Detection of OFDM Symbols in the Presence of Nonlinear Distortions. *IEEE Transactions on Communications*, 55(5), 854-860.
- [13] Liang, Y., Zhang, Q., Liu, Z., Shu, F., & Berber, S. (2009). Low-complexity sphere decoding for detection of OFDM systems in doubly-selective fading channels. *Electronics Letters*, 45, 797–798.
- [14] Mahmoud A. M. Albreem (2015). An Efficient Lattice Sphere Decoding Technique for Multi-Carrier Systems. *Wireless Personal Communication*, vol. 82, issue: 3, 1825-1831.
- [15] Ketonen, J., Juntti M., and Cavallaro J., (2010). Performance-Complexity Comparison of Receivers for a LTE MIMO-OFDM System. *IEEE Transactions on Signal Processing*, vol. 58, no. 6, 3360- 3372.
- [16] Hara, S. & Prasad, R., (2003). *Multicarrier Techniques for 4G Mobile Communications*, Boston: Artech House.

-
- [17] Sklar, B., (1997). Rayleigh Fading Channels in Mobile Digital Communication Systems- Part I: Characterization," *IEEE Comm. Mag.*, 35(7), 90-100.
- [18] Babu, SPK. Salleh, M. F. M., and Ghani, Farid, (2009). Reduced Complexity Optimum Detector for Block Data Transmission Systems. *IEICE Electron. Express*, 6(23), 1649-1655.
- [19] Proakis, J. G., & Salehi, M., (2007). *Contemporary Communication Systems using MATLAB*, Singapore: Thompson Asia Pte Ltd.
- [20] Anderson, J.B., (1997). Digital transmission Engineering. New York : *IEEE press*.