

Transmission Line Fault Detection: A Review

Hui Hwang Goh^{*1}, Sy yi, Sim², Asad Shaykh³, Md.Humayun Kabir⁴, Chin Wan Ling⁵,
Qing Shi Chua⁶, Kai Chen Goh⁷

^{1,3,4,5,6}Department of Electrical Engineering, Faculty of Electrical and Electronic Engineering,
Universiti Tun Hussein Onn Malaysia, 86400 Parit Raja, Batu Pahat, Johor, Malaysia

²Department of Electrical Engineering Technology, Faculty of Engineering Technology,
Universiti Tun Hussein Onn Malaysia, 86400 Parit Raja, Batu Pahat, Johor, Malaysia

⁷Department of Construction Management, Faculty of Technology Management and Business, Universiti
Tun Hussein Onn Malaysia, 86400 Parit Raja, Batu Pahat, Johor, Malaysia

*Corresponding author, e-mail: hhgoh@uthm.edu.my

Abstract

Transmission line is the most important part of the power system. Transmission lines a principal amount of power. The requirement of power and its allegiance has grown up exponentially over the modern era, and the major role of a transmission line is to transmit electric power from the source area to the distribution network. The exploded between limited production, and a tremendous claim has grown the focus on minimizing power losses. Losses like transmission loss and also conjecture factors as like as physical losses to various technical losses, Another thing is the primary factor it has a reactive power and voltage deviation are momentous in the long-range transmission power line. In essentially, fault analysis is a very focusing issue in power system engineering to clear fault in short time and re-establish power system as quickly as possible on very minimum interruption. However, the fault detection that interrupts the transmission line is itself challenging task to investigate fault as well as improving the reliability of the system. The transmission line is susceptible given all parameters that connect the whole power system. This paper presents a review of transmission line fault detection.

Keywords: Transformers, Transmission line, Fault in transmission line, Fault location techniques, Traveling wave method

Copyright © 2017 Institute of Advanced Engineering and Science. All rights reserved.

1. Introduction

Regarding the distribution system, transmission lines perform the most important part that is to transfer electric power from the generating station to load centres. Since the development of the distribution and transmission system, power system engineers have been an object for locating and detecting faults. As long as the fault detected in short duration, it provides a good service for protecting the apparatus as well as an open way for disconnecting the part where this incident happened at fault, and with the help of this, it gives safe way to the system from any damages. So it is needed to detect the fault otherwise due to fault it causes any disturbance which further tough time to the interconnected system that based on limitations. The structure of the transmission line constructed to investigate the location of the fault and can give separation only the part where the fault occurs. Stimulating method help in identify and isolate the fault in short period. A stable voltage can be achieved by the use of a series capacitor achieved. Series capacitors line inductance can be reduced by $\left(L \frac{di}{dt}\right)$ [1] along the line. If the line current leads the voltage, mean voltage increase. On the other side, there could be a voltage drop if line voltage is lagging by the line current. In this outlook, the voltage that has been boosted up and the voltage dropped decreased by the series capacitor as if the line inductance is smaller for the series recompensed line as associated with the unpaid line.

Suppose when more than two conductors develop contact each other or with the contact take place on the ground to 3 phase systems that are considered at fault which could be a balanced fault or unbalanced fault [2]. Due to these faults stresses are produced in power system equipment that could damage the power system components [3-5]. So to avoid these harms and to make power quality better, it is essential to know the reasons of fault as well as the location of the transmission lines and solve it properly. The problem of finding the type of

fault related to the transmission line as well as finding the location of the fault is a quite complicated job. The most exclusive problem of being worried is to investigate fault for the power industry. Apparently for the detection of fault some protective devices are used (relay) and also make control over it with the help of special control devices as well as devices called recording these all are used to cut the session where the fault is being occurred in the system [6]. Most important work is to collect all information regarding fault from this it is to be easy to investigate and make it possible to correct soon. Lots of researchers have been worked for knowing the skills for finding the locations of fault in distribution as well as in the transmission network related to methods of artificial intelligence like fuzzy set theory and artificial neural networks.

2. Fault Detection Method

Transmission lines operate spreading power from a generating station to remote load centres. Due to the existence of lightning strokes, the system has some mis-operation like a short circuit with this problem line could be overloaded hence it can damage the equipment. Due to the occurrence of a fault, the phase voltage does decrease and enormous current flow, which could damage the equipment. In this condition, fault detection play important role which can interrupt in the system very quickly. In the transmission line, the fault is comprised of ten parts that could interrupt in the three phase system, single line to ground, line to line fault, double phase to ground and the last one is three phase fault. A single line to ground fault occurs when it makes contact with the ground during the occurrence of fault the impedance. Z_{fag} , has some value it could not be considered zero impedance but still less than the impedance line. The magnitude of the fault current is frequently increased as compared to the normal current that is operated, but the magnitude of voltage remains unchanged frequently. Table 1 shows the occurrence of each type of fault.

Table 1. Type of Fault [b]

Fault category	Design	Occurrence (%)	Simplicity
Line-Ground	L to G	85	Very low
Line-Line	L to L	8	Low
Double line- Ground	L-L-G	5	Moderate
Three Phase	3 ψ	≥ 2	Very high

The series compensation is more efficient on transmission voltage that is essential to know because in series compensations have faced some technical problems when it is operated mainly with this problem is occurred like slow voltages and also high voltages [1]. These operational problems occurred due to a different type of caused like as line loading conditions and voltage control adjusted. In series compensations system has used a capacitor. This capacitors one side has to effectively controlled otherwise it will be based on voltage problems. For this reason, we can use series compensation for decrease voltage problems otherwise most probably overvoltage can cause these problems. On the other hand, in series compensation increase the voltage when the lines are heavily loaded and also low voltages occurred on the line. And flashovers occur due to high voltages or shrink the lifetime of devices and caused short circuits. We can use series compensation as a flows control of power. On the other hand, in a series compensated line based on current and voltage inversions each other [7].

The fault identification scheme for the series compensated by the fault and its magnitudes change in fault voltages as a positive sequence and terms of fault current change as a positive sequence [8]. When in series compensated lines developed by the algorithm for fault currents and phase voltages to get the decisions by using EMTDC/PSCAD. We can use a capacitor or don't have used capacitor regarding the testing process of series lines by just changing the source capacity, fault resistance, the fault inception angle, power flow direction those are the different system condition.

During the measure of current signals and voltage signals in both cases used fault location algorithm, two subroutines applied for locating faults and also for generalized fault loop model by taking help using different formulas [9]. The fault is occurred in anywhere the fault

doesn't maintain any distance of the parameters. The using of parameter both-end signals for measuring asynchronously compensating bank and it mainly depends on the location of the bank. In the special types of faults can be recognized by used to ATP-EMTP for the compensated of double-circuit series line. By using the method to verify the detected the fault in the transmission line is described on a double-circuit line. Moreover, this method is appropriate for the protection of uncompensated double circuit lines, and also series- compensated double circuit lines through the applied phase currents can measure [10]. To get the simulation result we of cognitive software of ATP-EMTP. Measurement channels the SCs & MOVs banks are developed by a complete model of the transmission line. The proposed algorithm used for two subroutines those are used to detect unbalance and balanced lines currents and approximately 99% correct fault categorization by symmetrical parallel line but in case of the line is unbalanced more than 85-95%accurate.

Furthermore, a double-circuit transmission line is a method which based on digital distance relaying and this method can protect the first-zone of transmission lines series double-circuit [11]. To an approximation, the fault distance as a considered from one end of the lines and this method is autonomous on fault current and source impedance. The double series circuit and using MATLAB/SIMULINK software of this method can guess exact fault distance. Through the algorithms to find the fault location, it is applicable for both single lines and double-circuit series lines. The series-compensated is anticipated at the relays of current differential are measured to locate more refined fault location solution [12].The technique of fault location which one is proposed by using the fault specified it is achieved by differential protective relays and also using this manner differential relays are utilized with communication infrastructure. With the purpose that is detaching for distinguishing the zones where the fault is occurred by the only line which is faulty precisely as well as indicating a particular type of fault both one is crucial that get help from data of one end only [13].The faults contain distinct frequency bands are generated by transient current waves and using the transient current signal that captures frequencies having two bands up to the 1dB that behave as wavelet like wavelet mother which is used. By using the frequencies of these two bands, it is determined by fault zone and to select faulted phase is used the mother wavelet. This phase which is faulty considered as average which has some value of factors of all current and by using 6 dB as mother wavelet to obtain a model signal. The external or internal regarding fault into the account by defining two of the energies related to signal model.

The transmission lines which are parallel related to problems of protection which rely on the 3 phase line voltages of the two parallel circuit lines and the six phase line currents at both ends is proposed [14]. Phasors of the current having magnitudes of equivalent phases are identified by differentiating line having double circuit each one of line it caused in internal faults. For the power it is compulsory for investigating and classifying the type of faults orrectly, it is efficiently distributed to different locations [15].During the fault, the tripping act of circuit breaker relies on waveforms of voltage as well as current and the accurate protection of transmission line is active tripping of circuit breaker ensures first. According to the classification of faults, energy level percentage has been done by using Discrete Wavelet Transform (DWT). With the help of Current Differential Pilot relay (CDPR), the series recompensed line can be protected that is debated by using transform wavelet [16]. We can get simulation results using MATLAB and used db4 to an analysis by mother wavelet. For detecting different types of faults, classification is done by wavelet based approach.

Another technique that is used for differentiation among the fault type which is a probability based technique called Bayesian linear discrimination [17].With the use of adaptive wavelet algorithm, BLD is caused for generating the wavelets. Wavelet of adaptive that is used in transmission line related to high speed protection system as filters. It is essential that the power should be transferred from the generating station to the consumers it should be kept away [18]. Moreover, in the transmission line, the probability of fault is to be considerable and signal processing in the digital distance protection is used. For locating faults are used Fourier transform and wavelet transforms. In case of protection of high speed EHV transmission line has been used the discrete wavelet analysis [19].Discrete wavelet analysis is accessible by using an algorithm which is related to detect and classify the fault. And all three phase signals of fault are identified by comparing different wavelet coefficients and used ATP-EMTP and MATLAB Wavelet toolbox for simulation. For EHV transmission line protection of the algorithm is quick, strong suitable and this is very prolific.

A new technique is proposed for boundary protection of series-compensated transmission lines and fault classification [20]. The frequency bands waves of transmission lines fault current can detect the fault location to have the appropriate boundary protection with different frequency bands. The frequency bands of 4 dB are a mother wavelet which can provide a transient fault current signal. It is indomitable by calculating the spectral energies of bands of dB4 of frequencies for the fault is internal or external. The average value of the frequency bands of 4 dB its wavelet coefficients of every single current wave are classified as a faulted phases. We can analyze power system disorder such as transmission line faults with Haar wavelets and Biorthogonal by using wavelet transform technique [21-24] appropriately. In this review paper, the approach of the mother wavelet transforms the frequency based on 4 dB is used to detect transmission line faults and in the index for transmission line can select which frequency wavelet is proper for this application.

3. Methods analysis

Most of the methods that have been analyzed depend on the values whether it could be phasor voltage or else current that is calculated given voltage as well as a current transformer at the substation or converting places. This is required for collecting the material at any rate three transformers that are connected to the end terminal of sub-transmission line or can say to transmission line [25]. Transformers that are connected with the end of a transmission line are very much luxurious particularly when HV lines get tangled in the system. Some algorithm fault impedance-based algorithm needed both current and voltage information [26]. The major disadvantages of using a current transformer during transient fault that is involved in their performance the namely possibility of magnetic core saturation [27]. With the probability of saturation condition, the flux remains up to the fixed for some duration of time when the voltage is no longer convinced respect of the secondary coil and the current of secondary kept beside the zero position. Time of saturation (period) relies on the magnitude of current especially on current transformer along with power factor and primary ratio X/R .

Magnetic field and conductors with these both the transmission line can be monitored while not having a current and voltage transformer. Because as we know, the conductors that have been connected in transmission line develops the magnetic field because of flowing of current. So from this analysis, the consequential magnetic field is developed that is formed from its conductor through the transmission line. In the end terminal of transmission line two sensing coils are used for identifying the magnetic field. The working of one sensing coil is tantamount to detect the vertical magnetic field intensity, and horizontal magnetic field intensity detects by another one [28]. The information can be resolved by these two dimensional magnetic fields intensity. In case of other fault detection, unexpected changes occur within the monitored data when faults are detected. In this case study, only the changes took place in the magnetic field forces that act as vertical as well as horizontal not having a single variation that is examined the voltages or else currents of the conductor [29]. Besides the transmission line along with algorithms, investigate fault as well as position of fault methods is to discuss related to the study of the predicted performance of a magnetic field. The link among detectors at both end terminals of a transmission line that transfer data related to currents as well as voltage and source impedance created by two terminal methods as showed in Table 2.

Table 2. Approaches to Fault detection

SL No	Methods	Types	Function Requirement
01	Base Impedance	One end Terminal Two end Terminal	This method is used for impedance of transmission.
02	Traveling Wave	One end Terminal Two end Terminal	In this method, one end terminal relies on time duration among voltage or else current on the other side two end terminals rely on the time duration that is to be delayed.
03	Magnetic Field		In these low detecting coils on the end terminal of vertical magnetic field strength, the rest other is sensed horizontal field strength.

3.1. Method of Impedance Based

In this method, two ways are single ended method used for a frequency that is related to phasor information and multi terminal method that is used for operating any data based on utilization. The method that is used for sensing the position of fault with the use of voltage and current called impedance base method in a transmission line to investigate the area of fault whether it is to occur or not. These calculations are needed by the impedance of the transmission line per unit length. That why the single ended impedance based fault does not need communications due to the simplest and fast fault location methodology. It has good numbers of application in power system having solid sequence with some value, having high ability to resist the fault as well as tapping the loads along with non-homogenous that gives challenges on the correctness of finding fault called single ended method [25]. It has 2 types of single-ended method that are simple reactance and Takagi-based

This method called simple reactance method used to work fine for a homogeneous system it is happening for the condition once fault does not have serious involvement with the resistance of fault and current that is drawn from the load. For the investigating fault, large errors are performed that is estimated by various parameters like sources of power system related to impedance, angles of transmission lines, impedance related to load. The main complications of one terminal impedance related to investigating fault method, it has been used only for measurement from one end of the transmission. This problem can be solved in several different ways. One of the best methods that state handled by Takagi method. With the use of Takagi method, it includes changing calculation and makes the difference between the current that is measured before and after the fault. From this analysis, it removes the fault impedance as well as removing these types of significant source.

The method that is used for the improvement of the correctness of single ended method called two ended method. For the load fault, this is necessary to have knowledge for collecting information for finding the position of phase fault. The problems related to one-terminal impedance based fault location method can be removed with the use of both sides of transmission line [28]. It is to be difficult to detect short time fault accurately having impedance related to finding position method of a fault having limited information exists for voltage as well as for the current and information which is already mentioned quite unnecessary for a condition called steady state.

3.2. Methods of Travelling Wave

In this method, two ways are used which are single terminal method and double terminal method. For the single terminal method, on the discontinuities of impedance single terminal method is used related to time duration among voltage and current [30-32]. It is furthermore distributed shown under:

- Category 1.1 Estimate the position of fault that is associated with time duration among finding fault and as well as transient fault.
- Category 1.2 Generate the pulse along with its reflection to investigate the fault rather than use the method of category 1.1 related to a transient fault.
- Category 1.3 Transient formed once the line is re-establish of the circuit breaker in view to investigating constant fault.

For the double terminal method, it used for a time duration that is to be delayed among appearances related to data at the close terminal of the transmission line.

- Category 2.1 Finding faults as a sensor in the transmission line it comprises on sending a signal. This act of duration of the time signal is used for locating time of the fault.
- Category 2.2 Establish the fault location by using the duration of time of transient where the fault is to be detected on the contradictory of the transmission line. To make more proper to this work the sensor should coordinate.
- Category 2.3 Traveling wave sensors for sensing fault position for the GPS category 2.2. Figure 1 illustate the concept of synchronizing fault detection timing with GPS satellite.

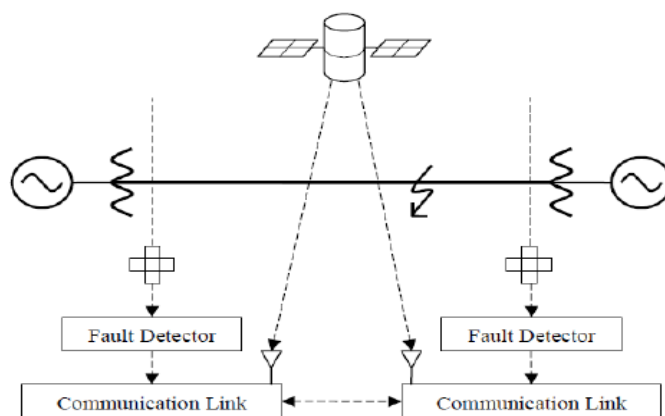

Figure 1. Synchronize fault detection timing with GPS satellite

4. Conclusion

Focusing on any research work regarding literature review is the very most important task because it builds up the thoughts and strong setting that can develop quickly. This development allows for making improvements based on unsolved questions thus clearly explain all limitations related to the progress of research work. Most of the prose worked on detection of fault related to the power system. For the improvement of power quality meaning that to make power purer, the compensated circuit is considered to be attached. While to enhance the system with reliability and supply of power respected time. Thus more important is to detect of fault as well as locating them as soon as possible.

Acknowledgement

The authors would like to thank the Ministry of Higher Education, Malaysia (MOHE), and the Office for Research, Innovation, Commercialization, Consultancy Management (ORICC), Universiti Tun Hussein Onn Malaysia (UTHM) for financially supporting this research under the FRGS grant No. 1529 and IGSP U667.

References

- [1] Kincic S, Papic, M. Impact of Series Compensation on the voltage profile of transmission lines. Power and Energy Society General Meeting PES. 2013; 1-5.
- [2] Shaaban SA, Hiyama, T. Transmission Line Faults Classification Using Wavelet Transform. 14th International Middle East Power Systems Conference (MEPCON'10). Cairo University, Egypt. 2010; 532-537.
- [3] Bendre A, Divan D, Kranz W, Brumsickle W. Equipment failures caused by power quality disturbances. In Industry Applications Conference. 39th IAS Annual Meeting. Conference Record of the 2004 IEEE. 2004; 1.
- [4] Brumsickle WE, Divan DM, Luckjiff GA, Freeborg JW, Hayes RL. Power quality and reliability. IEEE Industry Applications Magazine. 2005; 11(1): 48-53.
- [5] Bakshi UA, Bakshi MV. Protection And Switchgear. Technical Publications; 2009.
- [6] Lauglo M. Ground Fault Protection of Transmission Lines (Master's thesis, NTNU).
- [7] Jena P, Pradhan AK. A Positive- Sequence Directional Relaying Algorithm for Series Compensated Line. IEEE Transactions on Power Delivery. 2010; 25(4): 2288- 2298.
- [8] Nayak PK, Pradhan AK, Bajpai P. A fault detection technique for the series-compensated line during power swing. IEEE transactions on power delivery. 2013; 28(2): 714-22.
- [9] Izykowski, J., Rosolowski, E., Balcerek, P., Fulczyk, M. and Saha, M.M. Fault Location on Double-Circuit Series-Compensated Lines Using Two-End Unsynchronized Measurements. IEEE Transactions Power Delivery. 2011; 26(4): 2072-2080.
- [10] Pierz, P., Balcerek P. and Saha, M. M. A Method for Internal and External Fault Discrimination for Protection of Series Compensated Double-Circuit Line. IEEE Grenoble Power Tech. 2013; 1-6.
- [11] Kumar, R., Sinha, A. and Choudhary, G.K. A New Digital Distance Relaying Algorithm for First-Zone Protection for Series- Compensated Double-Circuit Transmission Lines. Third International Conference on Advances in Computing and Communications (ICACC). 2013; 102-106.

- [12] Saha, M.M., Rosolowski, E. and Izykowski, J. A fault location algorithm for series compensated transmission lines incorporated in current differential protective relays. The International Conference on Advanced Power System Automation and Protection. 2011; 706-711.
- [13] Sharma, R., Ahmad, A. and Shailendra, K. S. Protection of Transmission Lines using Discrete Wavelet Transform. International Journal of Innovative Technology and Exploring Engineering (IJITEE). 2013; 3(1).
- [14] Osman, A.H. and Malik, O.P. Protection of Parallel Transmission Lines Using Wavelet Transform. IEEE Transactions on power delivery. 2004; 19 (1).
- [15] Ashok, V., Bangaraju, K. G. V. S. and Murthy, V.V.N. Identification and Classification of Transmission Line Faults Using Wavelet Analysis. ITS Transactions on Electrical and Electronics Engineering. 2013; 1(1):117-122.
- [16] Pandya, V. J. and Kanitkar, S.A. A novel unit protection scheme for protection of series compensated transmission line using wavelet transform. Power Engineering Conference. 2007.
- [17] Perez, F.E., Orduna, E. and Guidi, G. Adaptive wavelets applied to fault classification on transmission lines. IET Generation, Transmission and Distribution. 2011; 5(7): 694–702.
- [18] Roshni, U., Niranjana, V., Prakash, C.D. and Srinivas, R. Location of Faults In Transmission Line Using Fast Fourier Transform And Discrete Wavelet Transform In Power Systems. Undergraduate Academic Research Journal (UARJ). 2012; 1(1): 84-86.
- [19] Solanki, M. and Song, Y.H. Transient Protection of EHV Transmission Line Using Discrete Wavelet Analysis. IEEE Power Engineering Society General Meeting. 3: 1868-1873.
- [20] Megahed, A.I., MonemMoussa, A. and Bayoumy, A.E. Usage of wavelet transform in the protection of series-compensated transmission lines. IEEE Transactions on Power Delivery. 2006; 21(3): 1213-1221.
- [21] Reddy, R.B., Kumar, M.V., Suryakalavathi, M. and PrasanthBabu, C. Fault detection, classification and location on transmission lines using wavelet transform. Electrical Insulation and Dielectric Phenomena. 2009; 409-411.
- [22] RavindraMalkar, VaibhavMagdum, Sunil Kumar Gunda. Transmission Line Fault Analysis Using Wavelet Theory. International. Journal of Engineering Science and Technology (IJEST). 2012; 4(6).
- [23] Mohammad, A.B. Travelling Waves for Finding the Fault Location in Transmission Lines. Journal Electrical and Electronic Engineering. 2013; 1(1):1-19.
- [24] R.P. Hasabe and A.P. Vaidya. Detection Classification and Location of Faults on 220 Kv Transmission Line Using Wavelet Transform and Neural Network. International Journal of Electrical Engineering & Technology. 2014; 5(7):32–44.
- [25] Kurt J. Ferreira, and Alexander E. Emanuel, Life Fellow, A Noninvasive Technique for Fault Detection and Location. IEEE Transactions on Power Delivery. 2010; 25(4): 3024-3034.
- [26] D. A. Tziouvaras, J. B. Roberts, and G. Benmouyal. New multi-ended fault location design for two- or three-terminal lines. Proc. Inst. Elect. Eng. Developments in Power System Protection, Amsterdam, the Netherlands. 2001; 395–398.
- [27] P. F. Gale, P. A. Crossley, X. Bingyin, G. Yaozhong, B. J. Cory, J. R. G. Barker. Fault Location Based on Travelling Waves. Fifth International Conference on Developments in Power System Protection. 1993; 54- 59.
- [28] M. Aurangzeb, P. A. Crossley, and P. Gale. Fault location on a transmission line using high frequency travelling waves measured at a single line end. Proc. Power Eng. Soc. Winter Meeting. 2000; 4:2437–2442.
- [29] Tumanski, S., Induction Coil Sensors – a Review, Measurement Science and Technology. 2007; 18(3).
- [30] Samapth, B. and Vijayabhaskar, K. Wavelet Based Protection Schemes for TEED Transmission Circuits. International Journal of Engineering Research and Applications (IJERA). 2012; 2(6): 931-940.
- [31] Saravanababu, K., Balakrishnan, P. and Sathiyasekar, K. Transmission Line Faults Detection, Classification, and Location Using Discrete Wavelet Transform. International Conference on Power, Energy and Control (ICPEC). 2013; 233-238.
- [32] Youssef, O. A. S. Fault classification based on wavelet transform. Transmission and Distribution Conference and Exposition IEEE/PES. 2001; 1:531-536.