

## Multi-output Portable Universal Power Supply Kit with Plug-and-Use Equipment for Emergency Application

A. Nazifah Abdullah\*, M. Asri Jusoh, Norkharziana Mohd Nayan, M. Syahril,  
N. Nadiyah Ayop

School of Electrical System Engineering, Universiti Malaysia Perlis, Pauh Putra Campus, 02600 Arau,  
Perlis, Malaysia, No. Telefon: 04-9885601

\*Corresponding author, e-mail: nazifah@unimap.edu.my

### Abstract

*This paper presents design and analysis of Multi-output Portable Universal Power Supply Kit (EPS Kit). This EPS Kit is intended as an alternative power supply kit to reduce the issue of a power outage. Lead Acid Battery which is considered one of the easiest sources that can be found during an emergency state is the best alternative energy source. The EPS Kit is designed to store the power in Lead Acid Battery as the main source and powered by the solar energy as the secondary source and will be providing both standard household alternating current (AC) and most common direct current (DC) power. This Kit is a stand-alone system comes with plug-and-use kit in which the system can be recharged using solar and AC power. The plug-and-use kit is equipped with intelligent multi-USB ports, adjustable dual mode NiCd, Ni-Mh, and Li-Ion battery which are Discharge/Charger mode, AC output port, LED lamp, and emergency electrical accessories. EPS Kit is also portable which installed with wheel and handle for mobility application. Production of EPS Kit is involved software and hardware. The software used are 3D CAD design software and circuit simulation software respectively for preliminary 3D drawing design and output circuit validation. Experimental results of the EPS Kit load testing, charging and discharging state are conducted in order to demonstrate the EPS Kit functionality and usage.*

**Keywords:** emergency power supply, eps, portable, solar, multi-output, plug and use

**Copyright © 2017 Institute of Advanced Engineering and Science. All rights reserved.**

### 1. Introduction

In this modern era, the dependent of energy source to carry our daily life activities is increasing with the flowing of time. The electrical energy is very useful at many level and it helps to improve our living standards and quality of life. Hence, it is become necessary to develop a portable device that could produce a backup source to fulfil the needs [1].

Developing a portable device that could store energy and supply it when needed is an invaluable solution to keeping up with the demand of energy needed. A portable device that could provide power and could be handy when used outdoors is of great significance of development. Examples of non-portable devices that can be handy when used outdoors are an electric fan and charger phone [1, 2].

A portable device is also necessary in extreme sport. It can be used to provide power to devices while hiking and camping outdoors. Examples of devices used camping outdoors that will utilize a portable solar charger are a flashlight light with a rechargeable battery. Portable device is also very helpful in rural areas such as forest and island which the power supply is hard to find [3].

The most important time to have a portable device is during the natural disaster and emergency state. For example, during the flood seasons, the power supply will be cut off. Therefore, the EPS Kit is created to reduce the problem on the energy supply demand. The EPS will be powered by Lead Acid Battery as the main source and solar energy as the secondary source. The Lead Acid Battery is easiest source can be found in during the emergency situation [4].

## 2. Research Method

There are quite a number of researches done previously based portable emergency universal power supply kit on which utilizes instant electric source and solar energy during an emergency cases cause by natural disaster or extreme activity such as hiking, camping and others [5].

There are many major sources of electrical energy such as batteries and generators. Batteries convert chemical energy into electrical energy. There are also other sources of electrical energy such as light sources and heat sources. Some sources produce direct-current energy whereas others produce alternating-current energy [3, 4].

### 2.1. Power Source

Lead acid batteries are large and heavy but provide the greatest power capacity and output. All lead acid batteries consist of flat lead plates immersed in a pool of electrolyte. The feature, along with their low cost, makes it attractive for use in motor vehicles to provide the high current required by automobile starter motors. Large format lead–acid designs are widely used for storage in backup power supplies in cell phone towers, high-availability settings like hospitals, and stand-alone power systems. For these roles, modified versions of the standard cell may be used to improve storage times and reduce maintenance requirements. Gel-cells and absorbed glass-mat batteries are common in these roles, collectively known as VRLA (valve-regulated lead–acid) batteries [6-8].

Light is a form of energy that is easily converted to electrical energy. Light energy is currently becoming very popular with eco-friendly to our environment and those who would like to purchase portable sources of energy for their own use. Solar energy is radiant light and heat from the Sun. It is an important source of renewable energy and its technologies are broadly characterized as either passive solar or active solar depending on the way they capture and distribute solar energy or convert it into solar power. Active solar techniques include the use of photovoltaic systems, concentrated solar power and solar water heating to harness the energy. Passive solar techniques include orienting a building to the Sun, selecting materials with favourable thermal mass or light dispersing properties, and designing spaces that naturally circulate air. Furthermore solar energy inexhaustible and independent, resource, enhance sustainability, reduce pollution, lower the costs of reducing global warming, and keep fossil fuel prices lower [9-11].

The Solar Cell device used to convert light energy into electrical energy is called a photovoltaic cell or a solar cell. Solar cells can convert not only light from the sun but also light from artificial sources such as light bulbs. Solar cells produce direct current electricity from the sun's rays which can be used to power equipment or to recharge a battery. When more power is required than a single cell can deliver, cells are generally grouped together to form PV modules or solar panels that may in turn be arranged in arrays. A solar cell is usually made of two layers of material: n and p. When solar cell is exposed to light, the two materials interact, producing an excess of electrons on one layer. A negative charge is thus developed. The other layer then has a deficiency of negative charge or a positive charge. The unbalanced in the electrons cause a difference voltage between the two layers. The difference in potential depends on the amount of light falling on the cell. The voltage is used to cause current to flow through a load connected to the cell. Thus, light acts as a source of electrical energy [9], [12, 13].

### 2.2. Methodology

The primary scope for this work is to design and analyses the solar rechargeable power supply to help reduce the issue of an outage during an emergency case, especially flood season. To achieve the scope, this project is divided into two sections, which is the development of software part and development of hardware part.

The hardware development part is basically inverter, control circuit, 12V lead acid battery, relay, switch and solar panel. Solar panel is to charge up the lead acid battery. Inverter is to converting DC to AC power supply for AC socket supply. EPS KIT contains all the electronic circuits to prevent damage to components and the main trolley to locate complete design for this EPS Kit.

3D CAD design software is used to sketch the preliminary 3D drawing design for a better view of the EPS Kit idea concept. The Proteus software is also applied on this project to stimulate and validate the output from the designed circuit.

Figure 1 shows the cross-function process of the EPS Kit includes 5 stages which are motivation, technical support, application, development and testing stage.

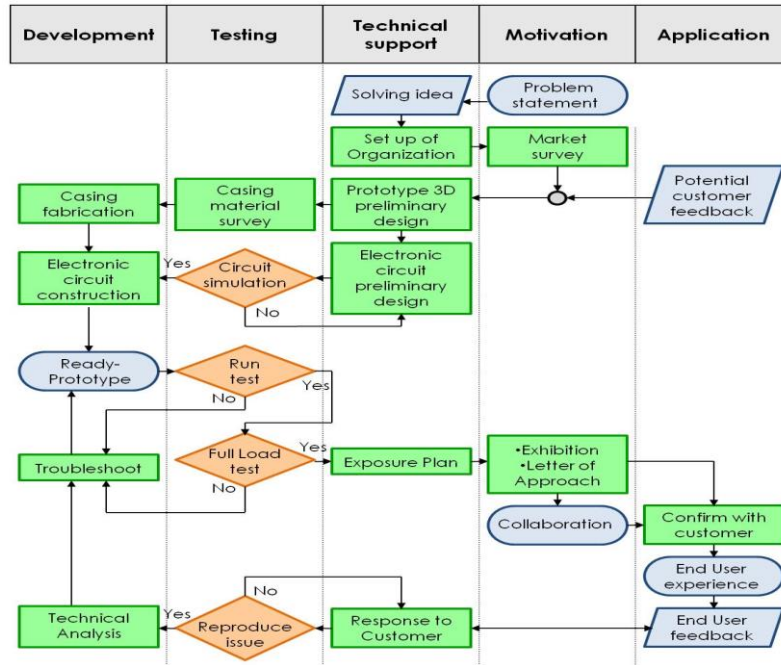

Figure 1. Cross-function Process of EPS Kit

The preliminary designs of EPS Kit are shown in Figure 2 and 3. Figure 2 shows the preliminary design of Universal Charger which consists of external DC/AC input ports, intelligent USB ports, LED battery charging level indicator, and Multi adjustable battery ports.

Figure 3 shows the illustration design sketch of the conceptual of Plug-and-Use Kit for the EPS Kit. The special feature of this kit is that it can be plug in directly to lead acid battery, to the trolley EPS Kit or even to common AC socket.

The full 3D drawing of EPS Kit in isometric view is shown in Figure 4 which shows all components that equipped in the kit. The Figure also shows the interior view and its compartment.

**2.3. Working Principle of Design Prototype**

The Portable Solar Power supply is supposed to capture solar energy, store it into a 12 volt lead-acid battery, and then provide useful power for a broad range of devices that operation on both AC and DC power. To gain a better understanding of how this project will function as single unit, a basic block diagram illustrating the functionality of this project is illustrating in Figure 5.

The prototype design will be powered by a rechargeable battery power source. The prototype design will be cost effective and user friendly as well especially during emergency situations. It will be equipped with 20 Watt Solar panel which used light energy or solar energy from the sun as the main source. It is environmentalist and renewable energy. Besides it also occupied with the boat type switch, universal charger, 3 pin AC supply, 5V DC supply, LED lamp and 12 V Lead Acid Battery. Universal charger consists of emergency port and quick charge port which can use during an emergency case, especially flood season. This design is universal and Multifunction besides, pollution free, no installation cost and installed with wheel and handle for mobility application.

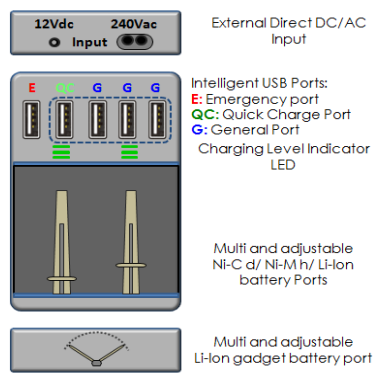

Figure 2. Preliminary Design of Universal Charger of EPS Kit

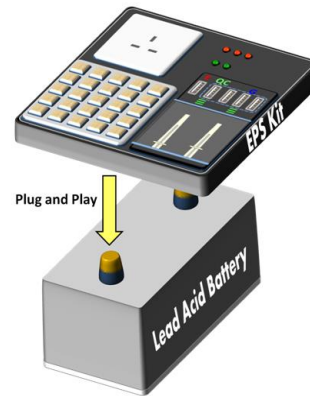

Figure 3. Illustration of Plug-and-Play Box of the EPS Kit

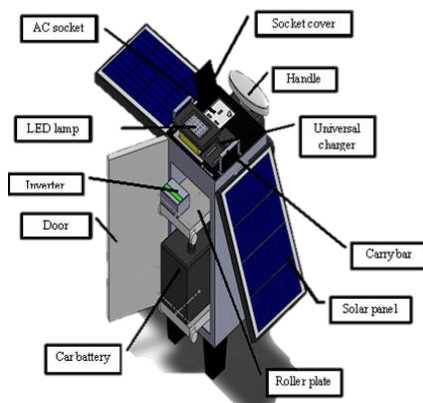

Figure 4. Preliminary design of EPS Kit with interior expose in isometric view

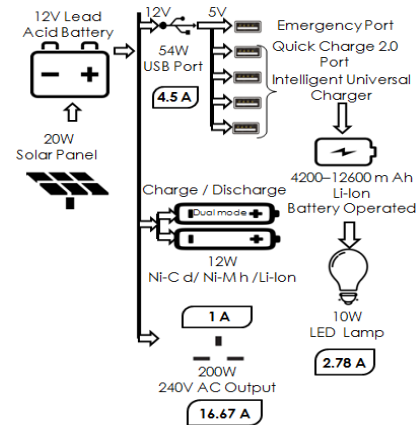

Figure 5. Block Diagram of the Functionality of the EPS Kit

### 3. Results and Analysis

Figure 6 shown Discharge Time (Hours) vs Discharge Current (A) graph for Lead Acid. Table 1 below shows the capacity of lead acid battery and Li-on battery with types of load, maximum rating current and estimated discharge duration.

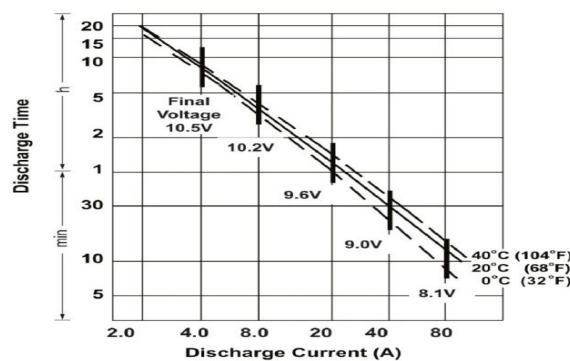

Figure 6. Datasheet of Discharge Time and Discharge Current Characteristic for Lead Acid Battery 40Ah [6]

Table 1. Battery 40Ah Estimated Duration Usage for Every Load

Capacity of battery	Load type	Maximum current	Estimated Duration
40 Ah	USB Port	4.5 A	9 h 00 min
40 Ah	Ni-Cd/ Ni-Mh/ Li-Ion Port	1 A	40 h 00 min
40 Ah	240V AC Output	16.67 A	1 h 30 min
40 Ah	Total Full Load	22.17 A	1 h 00 min
12.6 Ah	10W LED Lamp ~ full brightness	2.78 A	4 h 30 min
12.6 Ah	10W LED Lamp ~ half brightness	2.78 A	9 h 00 min

Table 2. Battery 40Ah Estimated Duration for Fully Charge

Capacity	Full voltage	Time to fully charged
40Ah	13.2v	8hours with 3amp

Table 2 shows the 12 V lead acid battery capacity, full voltage and time taken of full charge. Table 3 shows the inverter efficiency for the first and second day of experiment include with input power, output power and efficiency percentage in the table given. Thus, the average efficiency of the inverter is 79.5%.

Table 3. Experimental Result of Inverter Efficiency

Input power	Output power	Efficiency
183 watt	153 watt	84 %
167.33 watt	126.14 watt	75 %

Tables 4 (A) and (B) show 200 W AC load tested for EPS Kit by using 3x70 watt light bulb for the first day and second day which consist of starting time, ending time, voltage and current reading for battery and voltage and current reading for inverter.

Table 4. Experimental Result of 200 W AC Output

(a)		
Types	Start time	End time
Time	12.34pm	3.03pm
Battery voltage	12.34 V	10.7 V
Battery current		14.98 A
Inverter voltage		200 V
Inverter current		0.72 A

(b)		
Types	Start time	End time
Time	5.21pm	6.00pm
Battery voltage	12.15 V	11.71 V
Battery current		14.98 A
Inverter voltage		200 V
Inverter current		0.72 A

Table 5 shows the measurement of maximum rating current and voltage for Multi-USB ports and battery ports. This table also shows the starting and ending voltage for Lead Acid

Battery 40Ah. Table 6 below shows the experimental result for various type of load, capacity of battery and the total time taken for getting discharge. Hence, a fully charge EPS Kit can charge 2 Ipad Air, 2 Ipad, 2 Ipad mini, 2 Samsung Note 2 and 44.2 Ah li-ion Battery.

Table 5. Experimental Result of Measurement Current and Voltage

	Maximum current	Maximum voltage	Start voltage	End voltage
Lead acid battery status	-	-	13.18 V	11.69 V
Fast charging port	0.95 A	4.82 V	-	-
Port 2	0.91 A	5.01 V	-	-
Port 3	0.74 A	5.01 V	-	-
Port 4	0.74 A	5.01 V	-	-
Lion port 1	0.51 A	4.95 V	-	-
Lion port 2	0.51 A	4.95 V	-	-

Table 6. Experimental Result of Universal Charger Discharge Duration

Load type	Battery percentage	Capacity of battery	Discharge duration
Ipad air	13% left, port fast charging	8.8 Ah	9.8hours
Ipad	4% left, normal port	6.9 Ah	4.6hours
Ipad mini	10% left, normal port	4.5Ah	4.6hours
Samsung Note2	2% left, normal port	3.1Ah	4hour
12 W battery port	Approximately 0% left	4.2Ah	6.4hour
12 W battery port	Approximately 0% left	4.2Ah	6.4hour

#### 4. Conclusion

The prototype of the Portable Emergency Universal Power Supply Kit has been successfully developed. The group members had to do some research on power electronics, microcontrollers, and mechanical systems in order to create this project. Certain components were modified during the prototyping stage for this project. The research assisted the group to be well familiar with the project to be implemented such that if a component needed to be changed for the better one during the prototyping stage, the group was ready to adapt to this change and still meet the requirements of this project. Concerning efficiency, portability, and the capability to provide AC and DC power, the EPS kit met these requirements successfully. The most difficult challenge that the group encountered was designing a solar panel accurate size so that the solar panel will be compatible with EPS KIT trolley neatly and holder for solar panel at an angle of 45 degrees for solar tracking. Lastly, the experimental result is in a good agreement with predicted result and the experiment conducted is successful.

#### Acknowledgment

We would like to express gratitude to the Ministry of Higher Education Malaysia, School of Electrical System Engineering, Universiti Malaysia Perlis for providing the facilities. Thank you to En. Mohd Zulhisham, En. Mohd Hafiz bin Arshad, En. Baharuddin bin Ismail, En Zainuddin Isa for helping out during the experiments.

**Sponsor and Financial Support:** Fundamental Research Grant Scheme (FRGS) 2015.

#### References

- [1] Guiyin Yu. A New Type of Three-phase Emergency Power Supply (EPS). in *ICEMI' The Ninth International Conference on Electronic Measurement & Instrument*. 2009: 4-559.
- [2] Henrik Lund. Renewable Energy Strategies for Sustainable Development. *2006 Elsevier Science Direct Energy*. 2007; 32: 912-919.
- [3] Ji Hoon Hyun, Dong Sam Ha, Daniel Daeick Han, Chong-Min Kyung. A Solar Energy Harvesting System for a Portable Compact LED Lamp. in *IECON2015 Yokohama*. 2015: 1616.
- [4] Roopa Gangeputra, Nikhil Seshasayee, Usha A Joshi. Design, Analysis and Simulation of Portable Solar Power Inverter by Employing MSP-430F5132. in *2013 Texas Instruments India Educators' Conference*. 2013: 205.

- 
- [5] Baharudin, AD, *A Mobile Self-Powered Battery Charger*. Retrieved April 08, 2016, from [http://library.utm.my/index2.php?option=com\\_docman&task=doc\\_view&gid=4870&Itemid=208](http://library.utm.my/index2.php?option=com_docman&task=doc_view&gid=4870&Itemid=208) (2007, March).
- [6] CORPORATION PS. *Sealed Lead-Acid Batteries Technical Manual*. Retrieved April 08, 2016, from [http://www.power-sonic.com/images/powersonic/technical/1277751263\\_20100627-TechManual-Lo.pdf](http://www.power-sonic.com/images/powersonic/technical/1277751263_20100627-TechManual-Lo.pdf) (2009).
- [7] International BC. *Lead Acid Batteries*. Retrieved April 08, 2016, from [http://batteryCouncil.org/?page=lead\\_acid\\_batteries](http://batteryCouncil.org/?page=lead_acid_batteries) (2016).
- [8] Wikipedia. *VRLA Battery (valve-regulated lead acid battery)*. URL: [http://en.wikipedia.org/wiki/VRLA\\_battery](http://en.wikipedia.org/wiki/VRLA_battery).
- [9] V Ryan. *What is Solar Energy?* Retrieved April 08, 2016, from <http://www.technologystudent.com/energy1/solar1.htm> (2005).
- [10] Justin Tyner, Matt Coates, Dave Holloway, Kyle Goldsmith, Chris Daniels, Trevor Vranicar, John Roling, Dr. Dan Jensen, Mr. Al Mundy, Lt Col Brian Peterson. The Design of a Portable and Deployable Solar Energy System for Deployed Military Applications. in *Proc. 2011 IEEE Systems and Information Engineering Design Symposium*. 2011: 50.
- [11] D (n.d.). *Portable Solar Power Supply*. Retrieved April 08, 2016, <http://www.eecs.ucf.edu/seniordesign/su2012fa2012/g05/Conference Paper.pdf>
- [12] Luo-Qi Soh, Chee-Chiang Derrick Tiew. Building of A Portable Solar AC & DC Power Supply. in *Fifth International Conference on Intelligent Systems, Modelling and Simulation*. 2014: 445.
- [13] M Sitbon, S Gadelovits, and A Kuperman. Multi-output portable solar charger for Li-Ion batteries.