

A Comparison Study on Types of PV for Grid Connected Photovoltaic Power

Renuga Verayiah*, Anusiya Iyadurai

Department of Electrical Power Engineering, Universiti Tenaga Nasional, Jalan IKRAM-UNITEN, Kajang, 43000, Selangor, Malaysia

*Corresponding author, e-mail: renuga@uniten.edu.my

Abstract

Grid connected photovoltaic (PV) power systems is today's breakthrough for renewable energy source in electricity generation. Grid-connected photovoltaic (PV) power systems have the advantage of more effective utilization for highest renewable source of electricity generation and tendency to continual growth in the next years. The output performance of grid connected photovoltaic (PV) power systems is influenced by the impact of cell temperature or ambient temperature and solar irradiance of the solar module. This paper highlights the effect of output energy of solar module by implementing different types of solar module technology and selecting the highest energy output of the module technology for modelling and simulating the design of grid connected photovoltaic (PV) power system using Matlab/Simulink.

Keywords: photovoltaic, energy output, solar irradiance, ambient temperature, grid connected

Copyright © 2017 Institute of Advanced Engineering and Science. All rights reserved.

1. Introduction

Photovoltaic (PV) has heightened up growth on power generation sector as an alternate energy to overcome existing conventional energy problem such as extinction of fossil fuels, environmental issues like greenhouse effect and rise in electricity cost [1]. Grid-connected photovoltaic (PV) power systems have the advantage of more effective utilization for highest renewable source of electricity generation and tendency to continual growth in the next years. However, implementation of grid connected photovoltaic (PV) power systems has several drawbacks especially to power system operational problems like low conversion efficiency and unstable power output to grid system [2]. Consequently, these drawbacks will cause operational problems that affect the power system network, unbalanced voltage regulation and poor power factor [1-3]. Hence, grid connected photovoltaic (PV) power systems are essential to analyze the efficiency of output power before connecting to the grid for sustainable energy flow.

The effort in obtaining clean energy has led the worldwide countries like China, India, USA, and Canada to increase large scale PV installation in foreseeable future [1]. The European Union Renewable Energy forecasted a target of generating about 32% of power system from sustainable solar energy source by the year of 2030, with target of 100% by 2050 [4]. Solar energy is identified to be the next potential renewable energy in Malaysia where the geographical factor is an advantage to cruise solar energy for the electricity usages [5]. The tropical region of Malaysia with approximately 6 hours of sunshine per day suitable to increase the output performance of solar module [5], [17-18].

Typically, standard solar irradiance in Malaysia ranges between 800.W/m² to 1000.W/m². The nominal surrounding temperature is usually between 20°C to 40°C [5]. Hence, the output energy analysis test on three different types of PV module is carried out. The study analysis is carried out using the standard test conditions (STC) solar irradiation at 1000W/m² and ambient temperature at 25°C. The test location is located in Kuala Lumpur at 3.12° N, 101.55° E and the specifications of array are obtained from National Renewable Energy Laboratory (NREL) resources [6]. The test is performed according to the standard specifications of PV system by referring to the data available in National Renewable Energy Laboratory (NREL).

Aim of the study is to analyze the monthly energy output from different types of PV system technology such as Monocrystalline (Mono), Polycrystalline (Poly) and Amorphous

Silicon (Asi) module tested according to National Renewable Energy Laboratory (NREL) location data and standard PV specification data as described in Table 2 and Table 3 [6]. From here, the highest output energy of solar panel is determined according to the actual specification datasheets of the manufacturer's. Furthermore, the study is further carried out on highest output energy of PV module for modelling and simulating grid connected photovoltaic system using Matlab/Simulink.

2. Research Method

The test is initiated by analysing the energy output modelling of three types of PV module such as Monocrystalline (Mono), Polycrystalline (Poly) and Amorphous Silicon (Asi) using Matlab/Simulink based on NREL PV system specification. The test is performed according to the standard monthly output energy of PV system as described in Table 3 with the aid of the location sources as described in Table 2 from National Renewable Energy Laboratory (NREL) resources. The results are analysed based on the output value and then the test further carried on modelling and simulating grid connected on the highest energy output of PV module.

2.1. Modelling the PV Cells

The electrical specifications of I-V curve and P-V curve of solar module depends on the varying weather condition [7]. The values of voltage and current of solar module is influenced by the ambient temperature and solar irradiance of the selected location. Figure 1 illustrates the equivalent circuit diagram of single solar cell.

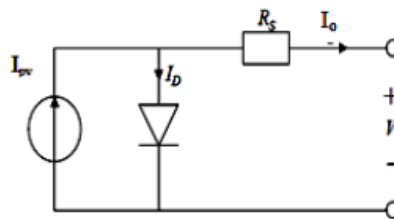

Figure 1. Model of single solar cell

I_{pv} represents the current generated by means of light of the solar cell that linearly dependant on the varying cell temperature and solar irradiance as described in Equation 1 [8].

$$I_{pv} = (I_{pv,n} + K_I \Delta T) \frac{G}{G_n} \quad (1)$$

2.2. Energy Output Modelling

The solar module output efficiency and types of solar are considered in modelling the output energy of the grid connected photovoltaic system. Photovoltaic module characteristics for standard test conditions are given in Table 1. The output energy of the solar module is obtained by the following equations. The cell temperature (T_c) is influenced by clearness index, (K_t) and nominal operating cell temperature (NOCT) is obtained from the Equation 2 by applying the actual value of standard ambient temperature referring to climate data from the Malaysia Meteorological Department site [9], [16].

$$T_c = T_a + (219 + 832K_t) \left(\frac{NOCT - 20}{800} \right) \quad (2)$$

The efficiency of solar array (η_p) is affected by the cell temperature of the array (T_c), module efficiency (η_r) and module temperature coefficient (β_p). Array efficiency is obtained in Equation 3 [7], [9]:

$$\eta_P = \eta_r \times [1 - \beta_P(T_C - T_r)/100] \quad (3)$$

The energy delivered equation by the photovoltaic array (E_p) is influenced by the array efficiency (η_p), area of the module (A) and irradiance (G). Hence, the energy delivered by the photovoltaic array (E_p) is configured from equation 4 [8], [10]. This energy is the capacity of (kWDC).

$$E_p = \eta_p(A \times G) \quad (4)$$

The energy delivered by the solar array to the grid connected power system, E_{grid} is obtained from Equation 5 [11] that are influenced by the power conditioning losses (λ_c), miscellaneous photovoltaic array losses (λ_p) and inverter's efficiency (η_{inv}). Hence, the actual energy delivered (E_{dvd}) is influenced by energy delivered to the grid system (E_{grid}) and PV energy absorption rate (η_{abs}) is determined in Equation 6 [10]. The energy is the capacity of (kWAc).

$$E_{Grid} = E_p(1 - \lambda_p)(1 - \lambda_c) \times \eta_{inv} \quad (5)$$

$$E_{dvd} = E_{Grid} \times \eta_{abs} \quad (6)$$

The monthly energy output of the solar module is obtained from the equation 7 where energy delivered by the photovoltaic array (E_p) is measured (kWh) and Solar Radiation in (kWh/m²/day).

$$\text{Monthly Energy Output} = E_p \times \frac{\text{Solar Radiation}}{\text{PerDay}} \times \frac{\text{DaysPer}}{\text{Month}} \quad (7)$$

The PV module that is tested in this research is Monocrystalline (Mono-Si), Polycrystalline (Poly-Si) and Amorphous Silicon (A-Si). Figure 2 illustrates the three types of solar module that will be tested for the monthly energy output in according to the daily solar irradiance at Kuala Lumpur in NREL resources. The specifications of the solar module are listed in Table 1.

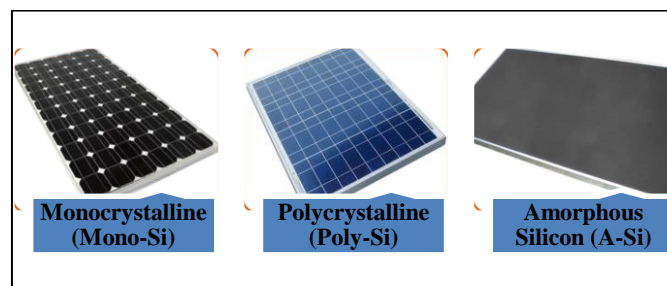

Figure 2. Model of single solar cell

Table 1. Parameters of type solar module characteristics for standard technologies [12-14]

Type of PV module	η_r (%)	NOCT (°C)	β_p (%/°C)	Area(m ²)	Variable	Speed (rpm)	Power (kW)
Mono-Si	13.0	45	0.4	1.63176	x	10	8.6
Poly-Si	11.0	45	0.4	0.92055	y	15	12.4
A-Si	5.0	50	0.11	1.21968	z	20	15.3

2.3. Matlab/Simulink Circuit Modelling

Figure 3 shows the modelling of grid connected photovoltaic power system with load using Matlab/Simulink software. The model comprises of basic components such as PV modules, irradiance block, temperature block, MPPT, Boost converter, load, transformer, diode, RLC filters, 3-level 3-phase VSC, feeders and utility grid to develop photovoltaic power system model. The details of the model are as follows [14]:

1. PV array delivering a maximum 100kW at 1000W/m²
2. 5kHz DC-DC Boost converter to increase the voltage
3. MPPT controller used and a 'Perturb and Observe' technique to optimize the switching duty cycle to extract maximum power maximum power.
4. 1980Hz 3-level 3-phase VSC to convert Dc voltage to Ac and keeping the system at unity power factor.
5. 10kVAR capacitor used to filter harmonics produced by the VSC.
6. 260/25kV 100kVA transformer
7. 25kV distribution feeder and 120kV of transmission system to represent the utility grid.

Modelling of grid connected photovoltaic power system is important because solar energy is promising power in future without degradation of environment through greenhouse gas emission and no storage losses from the power generated from photovoltaics power system. In Figure 3 the modelling of grid connected is illustrated using the highest monthly output energy PV and the model is built to study the impact of varying solar irradiance and cell temperature at the selected location in this research. The variation of the cell temperature and solar irradiance influences the output power and output voltage of the photovoltaics system.

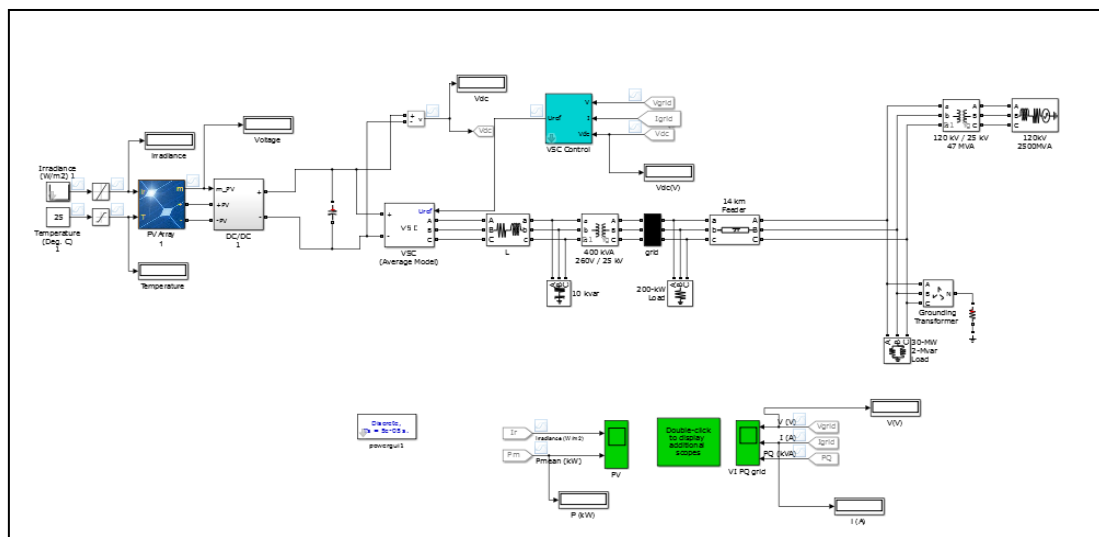

Figure 3. Grid connected Photovoltaic model using Matlab/Simulink

3. Results and Analysis

The monthly energy output on three different types of photovoltaic module such as Monocrystalline (Mono), Polycrystalline (Poly) and Amorphous Silicon (Asi) module is executed for open rack array at location 13.12° N, 1101.55° E in Kuala Lumpur with standard specifications of PV system using National Renewable Energy Laboratory (NREL) resources in Table 2 [6]. The monthly energy output data obtained by referring to Table 3. The energy output of Monocrystalline (Mono), Polycrystalline (Poly) and Amorphous Silicon (Asi) module is obtained from equation 7.

The PV specification used is standard reference for all three modules tested such as the parameters like type of array, degree of array tilt, array azimuth, the basic percentage system losses, inverter efficiency and DC to AC size ratio. The standard optimum energy output can be yield at 15° array tilt and 180° array azimuth according to Malaysian climate [15]. A

standard inverter efficiency is selected to perform the testing on three different types of solar module.

Table 2. Parameters taken from the national renewable energy laboratory resources [6], [15]

Location and Station Identification	
Requested Location	2.977415,101.730798
Weather Data Source	(INTL) KUALA LUMPUR,MALAYSIA 16mi
Latitude	3.12° N
Longitude	101.55° E
PV system Specification(Residential)	
DC System Size	100kW
Module Type	Standard
Array Type	Fixed (Open Rack)
Array Tilt	15°
Array Azimuth	180°
System Losses	15%
Inverter Efficiency	95%
DC to AC Size Ratio	1.1

Table 3. Monthly energy output data taken to calculate energy output of the 3 different pv modules [6]

Month	Solar Radiation (kWh/m ² /day)	Days Per Month
January	4.42	31
February	4.57	28
March	4.58	31
April	4.29	30
May	3.92	31
June	3.91	30
July	3.94	31
August	4.12	31
September	4.28	30
October	4.24	31
November	4.20	30
December	4.04	31

The average monthly energy output for Monocrystalline (Mono) is 40.3048kWh/month whereas Polycrystalline (Poly) module yields about 15.3542kWh/ month and Amorphous Silicon (Asi) module produces about 13.8188kWh/month. The results are obtained using Matlab/Simulink in Figure 4, Figure 5 and Figure 6. Hence, it is clearly seen that Monocrystalline (Mono) photovoltaic module has the highest energy output compared to Polycrystalline (Poly) and Amorphous Silicon (Asi). Since, Monocrystalline (Mono) photovoltaic module has the highest energy output therefore it is suitable to be implemented in grid connected photovoltaic power system model.

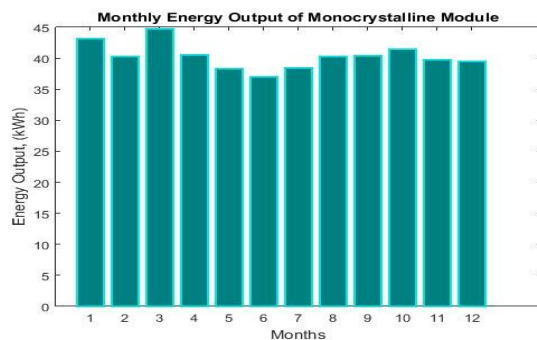

Figure 4. Monthly Energy Output for Monocrystalline (Mono)

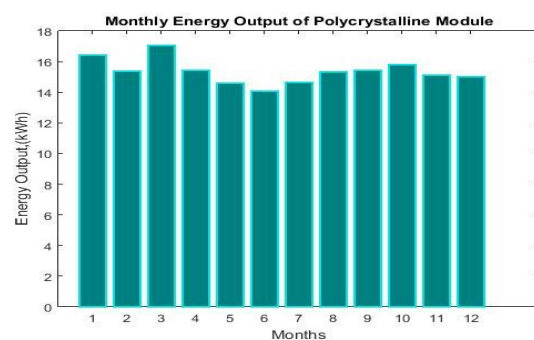

Figure 5. Monthly Energy Output for Polycrystalline (Poly)

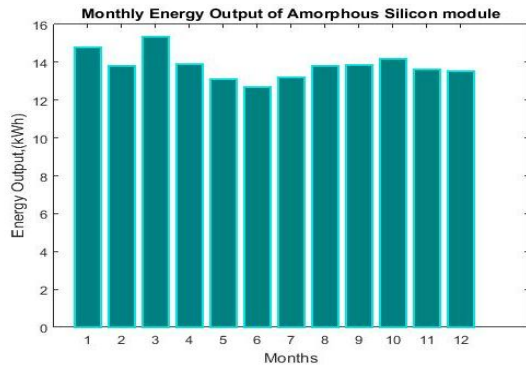

Figure 6. Monthly Energy Output for Amorphous Silicon (Asi)

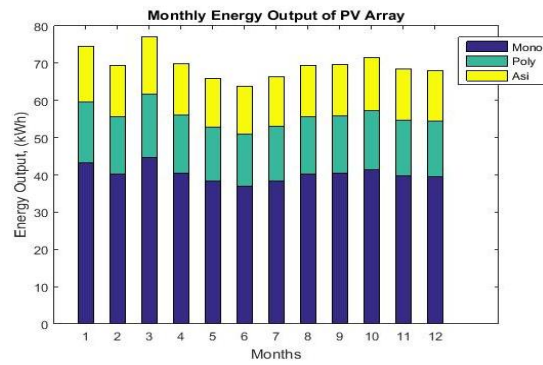

Figure 7. Monthly energy output of three modules tested

In Figure 7 the total monthly energy output of three types of module is combined show the differences of energy output produced by each module tested.

From the results in Figure 7, the energy yield for Monocrystalline module is highest, then followed by Polycrystalline and Amorphous Silicon. Hence, Monocrystalline material is chosen to be tested in grid-connected photovoltaic power system using Matlab/Simulink. The impact of cell temperature and solar irradiance is taken into account and the results are simulated in Figure 8 and Figure 9. In the simulation of model, a 100kW PV array SunPower SPR-31E-WHT-D is connected to 25kV utility grid is integrated with important components like a DC-DC boost converter and a three-phase three-level Voltage Source Converter (VSC). Maximum Power Point Tracking (MPPT) is executed in the model by using ‘Perturb and Observe’ technique.

The simulation design using Matlab/Simulink is used to obtain the varying cell temperature and solar irradiance parameters tested using SunPower SPR-31E-WHT-D solar array [12]. The varying cell temperature is tested from 0°C to 75°C with step size of 25°C at a constant solar irradiance value of 1000 W/m² is simulated. Hence, the results obtained shows that the open circuit voltage (V_{OC}) of PV array reduces as the cell temperature increases. As the temperature increases, the output voltage from the solar module decreases because every solar module is designated at standard temperature of 25°C and the temperature coefficient of SPR-31E-WHT-D is 0.27%/°C. Hence, for every degree above 25°C, the voltage decreases by 0.27%. The results of I-V curve and P-V curve at constant irradiance 1000 W/m² & specified temperatures are displayed in Figure 8.

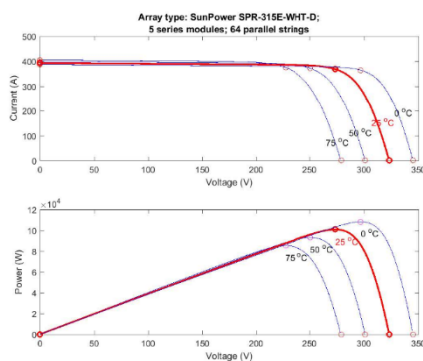

Figure 8. The I-V curve and P-V curve of SunPower SPR-31E-WHT-D with varying temperature

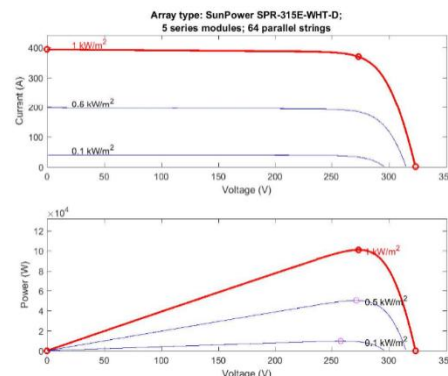

Figure 9. The I-V curve and P-V curve of SunPower SPR-31E-WHT-D with varying irradiance

The results obtained with varying solar irradiance and cell temperature is vice versa. The results obtained in Figure 9 illustrates the varying irradiance from $100\text{W}/\text{m}^2$, $500\text{W}/\text{m}^2$ and $1000\text{W}/\text{m}^2$. The current generated from the module varies directly with irradiance. The higher the solar irradiance value hence the higher the voltage and power output of the photovoltaic system.

The module I-V and P-V curves shows the standard temperature and solar irradiance values of voltage at maximum point (V_{mp}), the current drawn at maximum peak point (I_{mp}) and maximum power obtained (P_m) by using the module. The results obtained are from the graph in Figure 10 where voltage at maximum point (V_{mp}) is 54.7V , current drawn at maximum point (I_{mp}) is 5.76 and maximum power obtained (P_m) is 315.072W . Hence, the photovoltaic grid connected power system is suitable and able to meet load demand stated in the model.

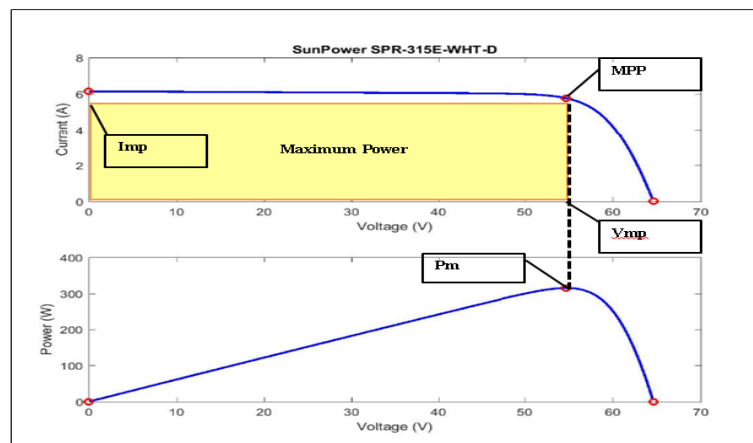

Figure 10. Module I-V and P-V curve of SunPower SPR-31E-WHT-D

4. Conclusion

Based on the research, the monthly output energy of the solar module is influenced by the impact of varying solar irradiance and ambient temperature. The study proves the variation of type of solar module with respect to area, influences the output energy executed from the solar module. Furthermore, the results show Monocrystalline (Mono) solar module material yields highest energy output which is suitable to be implemented in photovoltaic grid connected power system because the DC voltage capacity produced is high. Hence, AC voltage capacity that is gained from the high DC voltage conversion able to meet and sustain the load demands. Model is simulated using SunPower SPR-31E-WHT-D type of Monocrystalline (Mono) solar module by testing the impact of varying solar irradiance and ambient temperature. Thus, selection of most suitable photovoltaic technology is dependent on the photovoltaic system installation location and the area of the solar module used. This research on grid connected pv power systems are significant because solar energy is the most promising power in future without degradation of environment through greenhouse gas emission. Therefore, distributed generation particularly photovoltaics systems are more effective mitigation element of conventional energy usage and cheaper maintenance and installation cost compared to other conventional energy.

For more monthly output energy of photovoltaics accuracy, few parameters should be taken into account such as the diffusing irradiance, the zenith angle of the sun, the beam irradiance and beam radiation ratio on photovoltaic array to model photovoltaic grid connected power system. It is more accurate compared to obtain the output power energy instead of using standard variation of solar irradiance and cell temperature. Besides that, the average cost of the electricity produced from grid connected photovoltaics power system can be calculated based on the actual utility rate at a particular location.

Acknowledgement

We would like to thank University Tenaga Nasional for permitting this study.

References

- [1] Rakibuzzaman Shah, N Mithulanathan, RC Bansal & VK Ramachandramurthy. *A Review of Key Power System Stability Challenges for Large- Scale PV Integration*. 1364-0321/& 2014 Elsevier Ltd
- [2] SV Swarna Kumary, V Arangarajan Aman Maung than Oo, GM Shafiullah & Alex Stojcevski. *Modelling and Power quality analysis of a Grid-connected Solar PV System*. Australasian Universities Power Engineering Conference, AUPEC, Curtin University, Perth, Australia. 2014.
- [3] Masoud Zebarjadi & Alireza Askarzadeh. *Optimization of a reliable grid-connected PV-based power plant with/without energy storage system by a heuristic approach*. Science-Direct. 2016.
- [4] European Renewable Energy Council. *Re-thinking 2050: A 100% renewable energy vision for European Union*; April 2010 [Online]. Available: http://www2.warwick.ac.uk/fac/soc/pais/research/researchcentres/csgr/green/foresight/energyenvironment/2010_erec_rethinking_2050.pdf.
- [5] Faisal Mohammed Seif Al-Shamiry, Desa Ahmad, Abdul Rashid Mohamed Sharif. *Design and Development of a Photovoltaic Power System for Tropical Greenhouse Cooling*. Biological and Agricultural Engineering Department, University Putra Malaysia (UPM), American Journal of Applied Sciences 2007.
- [6] National Renewable Energy Laboratory (NREL) website. [Online]. Available: <http://www.pvwatts.nrel.gov/pvwatts.php>
- [7] HA Rahman, KM Nor, MY Hassan and MS Majid. *Assessment of PV Cell Performance under Actual Malaysia Operating Condition*. AUPEC09, Australia. 2009.
- [8] MG Villalva, JR Gazoli, E Ruppert F. *Modelling and Circuit Based Simulation of Photovoltaic Arrays*. University of Campinas-Brazil.2009 [Online]. Available: <http://www.ieeeexplore.ieee.org>
- [9] Malaysia Meteorological Department website. [Online]. Available: <http://www.met.gov.my>
- [10] MA Saqib. *A Photovoltaic System with Load Control*. University of Engineering and Technology, Lahore Pakistan.
- [11] Anca D Hansen, Poul Sorensen, Cars H Hansen and Henrik Bindner. *Model for a Stand Alone PV System*. Sandia Laboratory.
- [12] Datasheets of the solar panel manufacturer's [Online]. Available: <http://www.solardesigntool.com/components/modulepanelsolar/SunpowerSp-ecification>
- [13] Datasheets of the solar panel manufacturer's [Online]. Available: <http://www.mitsubishielectricsolar.com/specs>
- [14] Datasheets of the solar panel manufacturer's [Online]. Available: <http://www.pv.kaneka.co.jp>
- [15] Zeinab Abdallah, M. Elhassan, Muhammad.Fauzi, Moh.Zain, Kamaruzzaman Sopian, Arafah Awadalla. Output Energy of Photovoltaic Module Directed at Optimum Slope Angle in Kuala Lumpur, Malaysia. *Journal of Applied Sciences*, 2011.
- [16] HA Rahman, KM Nor, MY Hassan, S Thanakodi, MS Majid & F Hussin. Modeling and Simulation of Grid Connected Photovoltaic System for Malaysian Climate Using Matlab/Simulink. *International Journal on Advanced Science Engineering Information Technology*. 2016. (PEOCO 2010).
- [17] AR Amelia, YM Irwan, WZ Leow, M Irwanto, I Safwati, M Zhafarina. Investigation of the Effect Temperature on Photovoltaic (PV) Panel Output Performance. *International Journal on Advanced Science Engineering Information Technology*. 2016 (PEOCO2016)
- [18] WZ Leow, YM Irwan, M Irwanto, M Isa, AR Amelia, I Safwati. Temperature Distribution of Three-Dimensional Photovoltaic Panel by Using Finite Element Simulation. *International Journal on Advanced Science Engineering Information Technology*. 2016 (PEOCO2016)