

Development of an Automated Three-Phase Distribution Box System

N. M. Nor*, N. S. Zemri, S. A. Daud, T. Ibrahim, H. Daud

Universiti Teknologi PETRONAS, Department of Electrical and Electronics Engineering, Bandar Seri Iskandar, Perak, 32610, Malaysia

*Corresponding author, e-mail: nursyarizal_mnor@utp.edu.my

Abstract

Most electrical appliances require continuous power supply. For domestic use, crucial appliances such as refrigerator, aquarium and alarm system highly depend upon the continuity of power supply. However, if they are left without electricity due to power outage or blackouts caused by internal or external disturbance, the discontinuity of power supply could be a critical issue to some involving party. Blackouts may be due to short circuit, fault or the overloading of electricity mains. During power outage, Residual Current Device (RCD) detects fault currents from live to the neutral wire within circuit and will trip to prevent shock. This circumstance can increase safety when a house is left unoccupied. Be that as it may, the power will remain switched off until manually reset by man. Thus, this paper presented a new concept of Three-Phase distribution box system in order to overcome tripping problem. This system will be able to identify and isolate the fault using measurement of current flow into each Miniature Circuit Breaker (MCB) of appliances and current flowing out from each of the load. The measured current value will be compared and the maximum allowable difference is 30mA. If the current difference exceeds the maximum limit then the fault MCB will be detected. Hence RCD will be automatically close the circuit after determining the fault location via the motor operation to make sure of power stability and evade any property loss.

Keywords: Automated Three-Phase Distribution Box System; Miniature Circuit Breaker (MCB); Residual Current Device (RCD)

Copyright © 2017 Institute of Advanced Engineering and Science. All rights reserved.

1. Introduction

The world today is very dependent on supply of electricity regardless in industries or domestic use. It is important especially for the industrial sector which depends on a continuous supply of electricity to continue their operations. In the same way, for domestic appliances such as aquarium, refrigerator and alarm system have need of continual electrical supply even though the owners are not at home. However, an electrical fault may occur resulting in discontinuity of power supply to all the appliances.

Power system fault is defining as adverse circumstance that occurred in system. These adverse circumstances are like short circuit, current leakage, ground short, over current or over voltage. With the collective loads, voltages and short-circuit duty in distribution system, over current protection has turn out to be supplementary significant nowadays. Thus, power system protection is necessary to protect human and the appliances from damage. The operation of power system is inappropriate without the installation of any protection devices. The protection system is not only desired to be economical but reliable to be applied.

1.1. Electrical System's Fault

The probability of fault occurrence in three-phase system is common. In order to design any electrical equipment or system that can eradicate the entire potential fault in the system, it is not possible which result in why fault still exists. As cited by Abu Harun, a fault can be definite as irregular or accidental connections of the live element of circuit to each other live or earth element [1]. Faults can be alienated into two foremost kinds which are labelled as 'active' and 'passive'. Passive fault is a non-existent fault in the factual logic of the reality but is slightly circumstances which emphasize the system in a distance to its design limit, as to that active fault will eventually happen [11]. 'Active' fault is as soon as actual current flow from one point

conductor to earth (phase-to-earth) or consecutively from one point conductor to another (phase-to-phase) [7].

1.2. Current Sensor

Current sensor converts current for numerous functions comprising measurement or information transfer. It is used by getting a definite voltage level as input by prompting current from current transformer to the microcontroller. This current sensor (ACS712) will quantify the maximum current 20A from the load current as its primary nominal current (I_{pn}). The output voltage, V_{out} ($1 \text{ mA}=100 \text{ mV}$) which is connected to the Arduino UNO microcontroller as an analogue.

1.3. DC Servo Motor

Servo motors are employed in controlling robotics and applications. For speed control at high torques and accurate position, servo motors are used. It comprises of an appropriate motor and a sophisticated controller. Servo motors can be categorized conferring to the servomechanism controlling the motor. Servomechanism is a closed-loop system and relates to a system with controlling speed and position while servo motors are used to accurately control them, but in simple circumstance, only position may be controlled. TowerPro MG995 Metal Servo, the most suitable motor to be used in this project since it can provide high torque up to 9.4 kg-cm with low voltage and current operation [2].

1.4. Comparison of Three-Phase System Protection System

The comparison between all methods for detection and isolation of the fault is summarized as shown in Table 1. The feasible method for this project is by using a microcontroller sense the current continuously. A current sensor will be used for current measurement to identify any current leakage, overload or short circuit happen by comparing to pre-set value and then send the information to the controller. When the current exceeds the pre-set value, information will be sent from microcontroller to solid state relay for break the connection of circuit breaker. This two main flow can be related with method indicated before which are protection scheme using Arduino microcontroller and employment of solid state relay for protection of power system. Arduino coding will be appropriate virtual device program to incorporate the whole system. Using Arduino Uno microcontroller, the platform became simpler and conservative because it uses regular language programming which is C programming.

Table 1. Comparison of Protection System

Reference Number	Summary
[3]	Develop and experimentally demonstrate a new class of high-fidelity model-based fault detection and isolation filters for three-phase AC-DC power electronics systems. The structure of these filters is alike to that of a piecewise linear observer
[4]	Proposed a fault detector for digital relaying based on an Independent Component Analysis (ICA) This method can be practiced for fault classification and localization of a distance relay imitating its steadiness in all system changing condition. Fault detection algorithm was suggested grounded on the independent component of a current signal
[7]	Proposed method using Rogowski coil to study the feasibility of fault passing current sampling. Current sampling data will be used in developing an operative technique by using electronic transducer combined with multilayer perceptron (MLP) network to derive the short-circuit fault in order to finish the fault identification
[8]	Avoidance of fault current exceeded the cutoff capacity of the circuit breaker by quenching superconducting elements connected in the sound phase if critical current of superconducting fault current limiter (SFCL) exceeded
[9]	Suggestion using superconducting fault current limiter (SFCL) in neutral line of power system The device will investigate the current restraining attribute and power load of the superconducting element of flux-coupling
[12]	Presents the development of protection scheme by using Arduino that will continuously detects the current of load and temperature of a transformer. The protection scheme works and trips the load when the value of current and voltages rises from pre-set values
[15]	Employment of solid state relays in improving the power system protection as relays are responsible as the controller of any overload voltage or current and protection of the devices

2. Research Method

2.1. Operation of System Plan

The system is designed to detect fault location at MCB in three-phase design. Electrical fault usually occurs at a single circuit which could be among switches or sockets caused by overload, overcurrent or short circuit. With the intention of isolating the fault in a system, first, the location of the fault must be found. To measure the current flow in or out of each MCB at the electrical panel, certain test needs to be conducted. Current value measured at the input MCB will be compared with the current measured at the output of the load. If the difference value is higher the maximum limit, then the faulted MCB is detected. The maximum current difference allowable is only 30 mA, beyond than that is detected as fault. Hence, the faulty MCB connection will be automatically open so that others appliances can continue to operate as usual after automatic close the RCD.

Initially, the faulty MCB in the system will be detected and isolated. To discover fault in the system, fault trip test need to be conducted. The RCD will automatically close by motor operation after the fault is detected and isolated. This is the second objective of the project.

For a complete operation, both mechanisms are necessary to be employed in a system. To begin developing the prototype according to the design specified, the tools are prerequisite in thought such as hardware and software. Afterward, when the system planning is done, a project circuit will be designed and developed. The development stage of the project continues until the projected result is met. Once completed, the real prototype will be developed. Finishing test upon project completion will be made subsequently when all the system effectively combined.

2.2. Auto-Reset RCD

The electrical system will open the circuit when a fault occurred. An auto reset of RCD will be implemented to close the circuit to turn the electricity back to normal flow in the system. 6 V servo motor is selected to close the RCD connection using spring plunger. With certain alteration inside the panel box with a steel rod and aluminium, the device could simply close the circuit with the RCD plunger. The electrical signal will be converted into the mechanism which it will work when the motor rotates. Choice of the motor is very important because the RCD plunger is made from spring trap piece which is, in fact, it is inflexible to turn back to original state when tripped, the choices of the motor are essential. In this project, DC servo motor will be used for accurate speed control at high torques and position. Figure 1 at the left-side part shows the initial design of spring plunger but this design does not seem practical because the movement of the motor to push RCD switch back to original place is not smooth. The new design discovered shown at the right-side figure which is more practical to be implemented. This design can help the movement of motor to push back RCD switch back to original place. It can tightly grip the RCD switch.

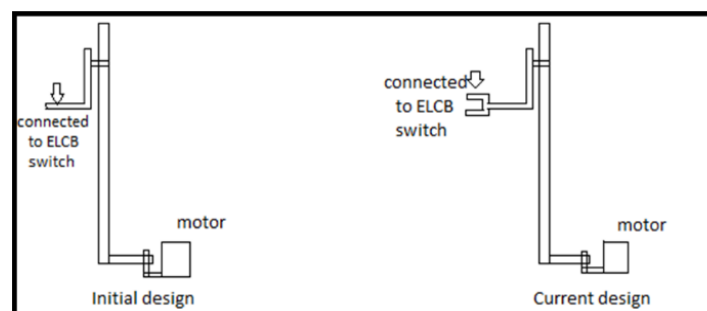

Figure 1. Design of spring plunger

2.3. Fault Detection

Electrical fault usually happens at a single circuit, could be among switches or sockets. Those faults might happen as the outcome of an overcurrent condition for example overload or high-level short circuit at any point in the electrical system or lightning. Hence, fault protection is

needed to avoid from the unforeseen power outage. With the aim of detecting and isolating the fault, the location of the fault needs to be searched. It can be accomplished through current measurement evaluation by measuring the amount of current flow into each of MCB to the appliances by using current sensor and this value will be compared with the current measured at output of the load. If the difference value is within allowable limit, then the appliance is operating at normal condition but if the value is above the maximum limit then faulted MCB will be detected. The faulty MCB opened the circuit and signal will transmit to RCD to reclose the circuit for the power supply turn back to normal operation. Figure 2 shows the connection of current sensor at the input of MCB and output of the load. The output of the current sensor is connected to the Arduino. The signal will be send to solid state relay to open the MCB connection if the breaker is detected as faulty MCB.

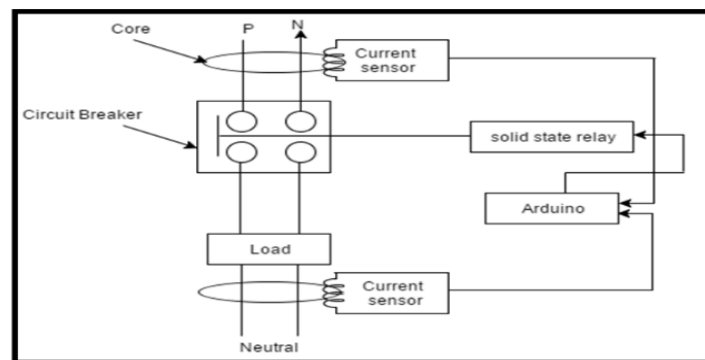

Figure 2. Circuit diagram of fault detection

3. Results and Analysis

3.1. Spring Plunger and Motor Holder Fabrication

Figure 3 shows the mechanism part that helps in DC motor movement to push the RCD switch back to the original place. The idea to design spring plunger mechanism has been inspired by an online streaming video. AutoCAD software is used to design DC motor's holder. DC motor needs a gripping mechanism in order to hold motor tightly so that the movement of the motor can operate efficiently. The holder of the DC motor is made up from Perspex material. Tables and Figures are presented center, as shown below and cited in the manuscript.



Figure 3. Spring plunger

3.2. Analysis of Motor Operation

The motor will move 90 degrees as shown in Figure 4 to push the RCD switch back to original place. The signal will be transmitted from Arduino to the motor after the fault is detected and isolated. This motor is capable to move the RCD switch with 90-degree movement within

1.5 ms. Motor movement consists of three condition: (1) normal condition; 0 degree (no movement), (2) trip condition; 90 degree movement and (3) reset condition; reverse the rotation (90 degree) back to original place.

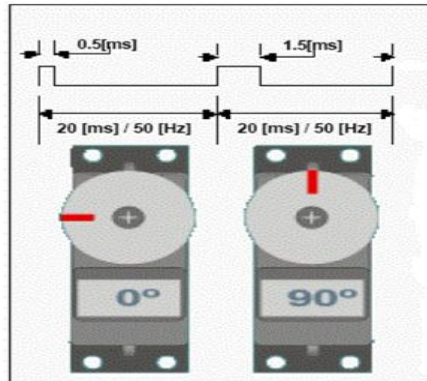

Figure 4. Phase of motor movement

3.3. Current Sampling Method

In order to identify there is a leakage current happened on the line, the current measured at the input of MCB and output of the load must be compared. In real life application, the normal load that been used is alternating current (AC) load. The output current for this type of load is in sinusoidal form. This might lead a problem in determining either the input current flowing into each of MCB and the current flowing out of the load is the same or not. There is no issue if the DC load is used since this type of load generate DC output hence it is easier in determining the current value because the value will not fluctuate like alternating current. Current sampling technique has been used to sample an alternating current measured at the input of the MCB and output of the load. AC voltage will be a sample for one second (1 s) while recording the maximum and minimum value. From this, the peak to peak voltage (V_{pp}) is calculated. This V_{pp} value then converted to root mean square of the voltage value (V_{rms}) by getting peak value of voltage. This V_{rms} value then is used to calculate root mean square of the current value (I_{rms}). In alternating electrical current, RMS value is equal to direct current that will produce the same average power dissipation in a resistive load. The I_{rms} value is not a straightforward conversion from voltage to current because the current sensor is used to measure current and converts it to voltage in order to be readable by Arduino and it involved sensitivity of the current sensor. Hence, the calculation must include the sensitivity of the ACS-712 current sensor.

The analogue value at each of the current sensors that connected to the input and output of the load are depicted in Table 2. A normal load such as solder fan, AC machine and bulb have been connected to measure current flow at the load. The analogue value was taken using serial monitor at the Arduino software and the current difference is calculated as in Table 2.

Table 2. Result of the Measurement

Reading	Analogue value	Result			Current difference (Amp)
		V_{pp} (Volt)	V_{rms} (Volt)	I_{rms} (Amps)	
1	Sens1:45	Vpp1: 0.219	Vrms1:0.077	Irms1:0.77	0.03
	Sens2:43	Vpp2: 0.210	Vrms2:0.074	Irms2:0.74	
2	Sens3:46	Vpp1:0.224	Vrms1:0.079	Irms1:0.79	0.27
	Sens4:30	Vpp2:0.146	Vrms2:0.052	Irms2:0.52	
3	Sens5:4	Vpp1:0.019	Vrms1:0.007	Irms1:0.07	0.02
	Sens6:3	Vpp2:0.014	Vrms2:0.005	Irms2:0.05	
4	Sens3:4	Vpp1:0.019	Vrms1:0.007	Irms1:0.07	0.00
	Sens4:4	Vpp2:0.019	Vrms2:0.007	Irms2:0.07	
5	Sens5:9	Vpp1:0.043	Vrms1:0.015	Irms1:0.15	0.13
	Sens6:1	Vpp2:0.005	Vrms2:0.002	Irms2:0.02	

From Table 2, Reading 2 and Reading 4 indicate that a fault occur at MCB 2 and MCB 3 known as Detect 2 and Detect 3 as shown in Figure 5 and Figure 6 because the value of current difference already exceed 30 mA. It can be proven that the maximum allowable difference is only 30 mA as indicated in Reading 1. If a leakage current happened in the line, the output current of the load will be reduced. Hence the current difference between the input of MCB and output of the load must be beyond 30 mA. The location of faulted MCB will be detected.

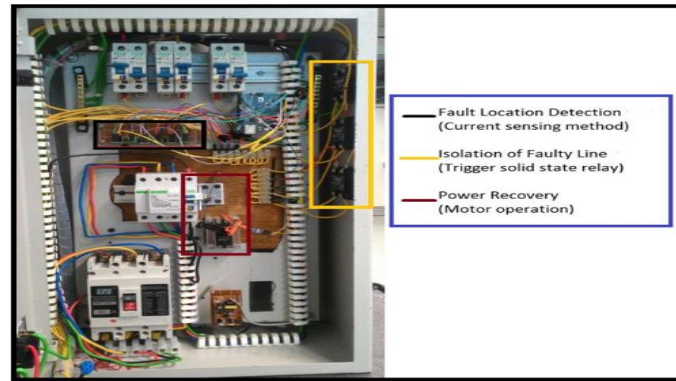

Figure 5. The fabrication process of the prototype

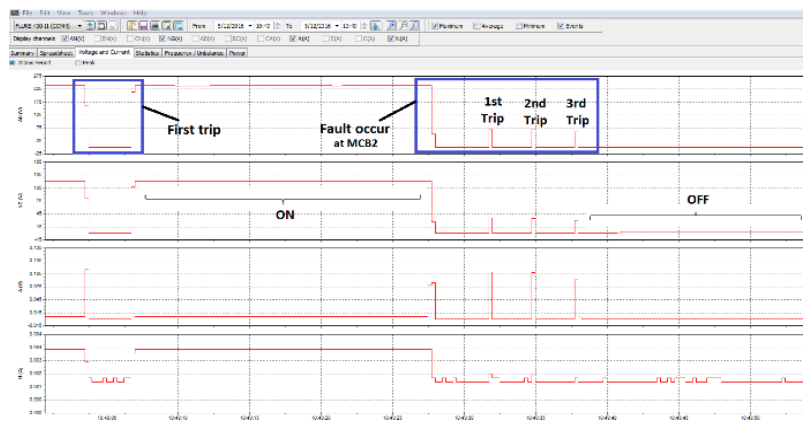

Figure 6. Voltage and Current Waveform at MCB2

3.4. Prototype Development

The fabrication of this prototype has taken almost two weeks for completing the wiring and all the connection to the components. There are three new features as indicated in Figure 5 which includes fault location detection, isolation of the faulty line and power recovery mechanism. For power recovery mechanism, this part is like “plug and play” in this distribution box but for fault detection and isolation part, it requires some modification in the wiring system.

3.5. Prototype Testing

This prototype has been tested by connecting normal load while for applied faulty condition, tripping load have been used. Based on the graph, when fault occur (1st Trip) as indicate in Figure 6, there is leakage current flowing at the earth line. This caused RCD switch to trip. RCD switch will be reset one time by using a servo motor. This motor will be triggered to move 90 degree by sending signal from Arduino for recovers the power supply. If there is no permanent fault in the system, the power supply can be turned back to normal condition (ON state) by only reset one time of the RCD switch. But if there is permanent fault occur as shown

in Figure 8 (fault occur at MCB2), this servo motor will reset three times before it goes to the function for checking fault location and isolate it. Fault location will be detected if there is a difference in current value at the input of MCB and output of the load. To isolate it, solid state relay will be triggered to low voltage (0 volt), hence there is no current flow through the faulty MCB (OFF state). After fault has been isolated, the power supply can be turned back by resetting the RCD switch one time as labelled in Figure 7.

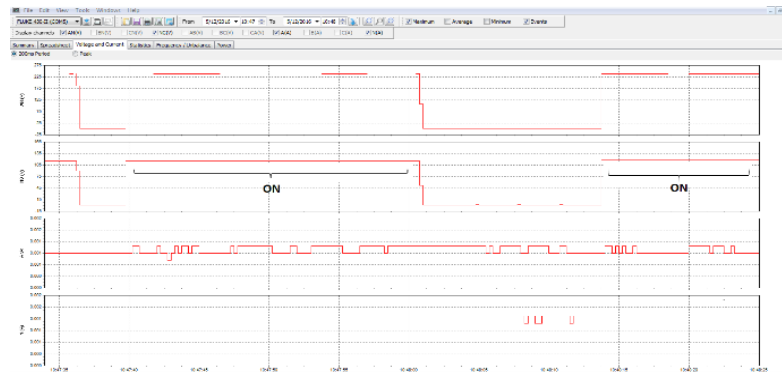

Figure 7. Voltage and Current Waveform at MCB3

4. Conclusion

The aim of this project has been achieved by developing an automated three-phase distribution box system including auto-reset the RCD and auto detection for any lasting fault. A mechanism that enables an auto-reset the RCD had been developed. As stated in result and analysis section, the developed system is able to identify and isolate the fault. Above all, the prototype could identify and isolate the fault in less than 2 seconds, provide an effective solution in recovering power supply and enhancing power system protection.

References

- [1] Abu Harun Z. Over Current Protection relay using pic micro controller. Universiti Malaysia Pahang. 2007.
- [2] Daware K. How does a servo motor work? | electricaleasy.com. Electricaleasy.com. Retrieved 19 June 2016, 2015. from <http://www.electricaleasy.com/2015/01/how-does-servo-motor-work.html>
- [3] Ding X, Poon J, Celanovic I, Dominguez-Garcia A. Fault Detection and Isolation Filters for Three-Phase AC-DC Power Electronics Systems. *IEEE Trans. Circuits System I*. 2013; 60(4): 1038-1051.
- [4] Dubey H, Mohanty S, Kishore N. *Abrupt Change Detection of Fault in Power System Using Independent Component Analysis*. International Conference on Signal Processing, Communication, Computing and Networking Technologies. 2011: 689-664.
- [5] Electrical Technology. What is the Difference Between Neutral, Ground and Earth? - Electrical Technology. Electrical Technology. Retrieved 19 June 2016, from <http://www.electricaltechnology.org/2015/08/difference-between-neutral-ground-and-earth.html>
- [6] Electrical Technology. All about MCB, its Construction, Working, Types & Applications. - Electrical Technology. Electrical Technology. Retrieved 19 June 2016, from <http://www.electricaltechnology.org/2016/02/mcb-miniature-circuit-breaker-types-construction-working-uses.html>
- [7] Jin L, Yuan Z, Guan Y, Zheng X. *Research on the Identification of the Short-circuit Fault in Power System Based on the Information of Electronic Transducer*. The 8th International Power Engineering Conference. 2007: 1203-1206.
- [8] Jung B, Choi H, Cho Y, Chung D. Current Limitation and Power Burden of a Flux-Coupling Type SFCL in the Three-Phase Power System According to Turn's Ratio and Fault Type. *IEEE Trans. Appl. Supercond*. 2011; 21(3): 1225-1228.
- [9] Lim S, Moon J, Kim J. *Fault Current Limiting Method using a SFCL in a Neutral Line of a Three-Phase Power System*. International Conference on Electrical Machines and Systems. 2016: 1648-1650.
- [10] Mc Fadyen S. Three Phase Power Simplified. Myelectrical.com. Retrieved 19 June 2016, from <http://myelectrical.com/notes/entryid/172/three-phase-power-simplified>

- [11] Minakawa T, Ichikawa Y, Kunugi M, Shimada K, Wada N, Utsunomiya M. Development and implementation of a power system fault diagnosis expert system. *IEEE Trans. Power Syst.* 1995; 10(2): 932-940.
- [12] Naseem A, Alam N. *Protection of distribution transformer using arduino Platform.* Science International. 2015; 27(1): 403-406.
- [13] Three-phase electric power. Wikipedia. Retrieved 19 June 2016, from https://en.wikipedia.org/wiki/Three-phase_electric_power
- [14] Three-phase Power Systems. (2016) (1st ed.). Retrieved from <http://www.allaboutcircuits.com/textbook/alternating-current/chpt-10/three-phase-power-systems/>
- [15] Verma N, Gupta K, Mahapatra S. Implementation of Solid State Relays for Power System Protection. *International Journal of Scientific & Technology Research.* 2015; 4(6): 65-70.
- [16] Work education kvk. 2016. WORK EDUCATION: April-May Class VI to XII. Workeducationkvk.blogspot.my. Retrieved 19 June 2016, from <http://workeducationkvk.blogspot.my/p/april-may-class-vi-electrical-safety.html>