

A Review on Constant Switching Frequency Techniques for Direct Torque Control of Induction Motor

Auzani Jidin^{*1}, Kasrul Abdul Karim², Khairi Rahim³, Logan Raj Lourdes Victor Raj⁴, Sundram Ramahlingam⁵, Tole Sutikno⁶

^{1,2,3,4,5}Faculty of Electrical Engineering, Universiti Teknikal Malaysia Melaka (UTeM), Hang Tuah Jaya, 76100 Durian Tunggal, Melaka, Malaysia

⁶Department of Electrical Engineering, Faculty of Industrial Technology, Universitas Ahmad Dahlan (UAD) Janturan, Umbulharjo, Yogyakarta 55164, Indonesia

*Corresponding author, e-mail: auzani@utem.edu.my

Abstract

The Direct Torque Control (DTC) of induction machine has received wide acceptance in many Variable Speed Drive (VSD) applications due to its simple control structure and excellent torque dynamic control performances. However, the conventional DTC which employs a two-level inverter and hysteresis controllers produces two major drawbacks, namely, larger torque ripple and variable switching frequency, which might produce a very high switching frequency (or power loss), particularly at a very low speed operation. This paper highlight the common methods used to provide the constant switching frequency for DTC drives for Induction Motor that able to minimize the power losses and reduced the torque ripple.

Keywords: Direct Torque Control, constant switching frequency, Induction Motor, two-level inverter, hysteresis controllers

Copyright © 2017 Institute of Advanced Engineering and Science. All rights reserved.

1. Introduction

Nowadays, the AC motor drives have gained wide acceptance in many industrial applications since the AC motors have low maintenance, rugged, high-efficiency and able to operate at very high speed operations. Since 1970's, variations of vector control techniques for AC motor drives were proposed which mainly aim to provide excellent dynamic control performances, comparable to that obtained in the DC motor drives. The evolution of AC motor drives is in line with the growth of microprocessor and solid state switching technologies that enables fast computational algorithm and high switching frequency.

The Direct Torque Control (DTC) method was introduced in the mid of 1980's by Takahashi and Noguchi [1]. This method has received significant interest in recent years due to its simplicity and superior torque dynamic control. The DTC eliminates the use of a frame transformer, current controllers and a position sensor. Moreover, the DTC does not totally depend on machine parameters to estimate the flux and torque. In fact, the DTC only requires the information of a stator resistance for estimations. This facilitates the control in DTC to have lesser sensitivity on parameter variations due to temperature changes. To establish a fast instantaneous torque and flux control, a decouple control structure is employed in DTC scheme. With a decoupled control structure, the torque and flux are controlled instantaneously using their respective a three-level hysteresis comparator and a two-level hysteresis comparator. In this way, the errors of torque and flux are restricted within their hysteresis bandwidths. The comparators provide error statuses to be index into a look-up table for selecting appropriate voltage vectors to restrict the errors

Obviously, the DTC scheme gradually replaces the FOC for many industrial applications which require excellent torque dynamic control with simple control implementation. However, the DTC which is associated with hysteresis controllers has major drawbacks, namely larger torque ripple and variable switching frequencies. There are numerous journal papers have been publish lately on producing a constant device switching frequency for DTC scheme such as the predictive control, SVM control, fuzzy logic control and CFTC method.

2. Direct Torque Control of Induction Machine

Direct Torque Control (DTC) is one of the most popular method, recently used in many electric motor drive applications due to its simpler structure and excellent torque control. It employed hysteresis controllers and a look-up table. The look-up table is used to tabulate suitable voltage vectors and they are selected according to the error statuses of torque and flux hysteresis comparators. It was extensively reported in several papers that the selection of voltage vectors using the look-up table can produce fast instantaneous torque and flux control.

Figure 1 depicts a structure of DTC of induction machine. It consists of two hysteresis comparators, a look-up table and estimators of torque and flux to establish DTC drive of induction machine. The DTC employs a pair of hysteresis comparator; one utilizes a two-level hysteresis comparator for controlling the stator flux and the another one uses a three-level hysteresis comparator for controlling the torque. By employing the two hysteresis comparators, this establishes a decoupled control or independent control of torque and flux, which provides fast instantaneous control. A simultaneous control of torque and flux can also be established by the same application of voltage vectors. The switching of voltage vectors is based on a look-up table. In such a way, the simultaneous control is accomplished as the error statuses produced from the hysteresis comparators and flux sector information are used to index the look-up table for selecting appropriate vectors to compensate the errors of torque and stator flux.

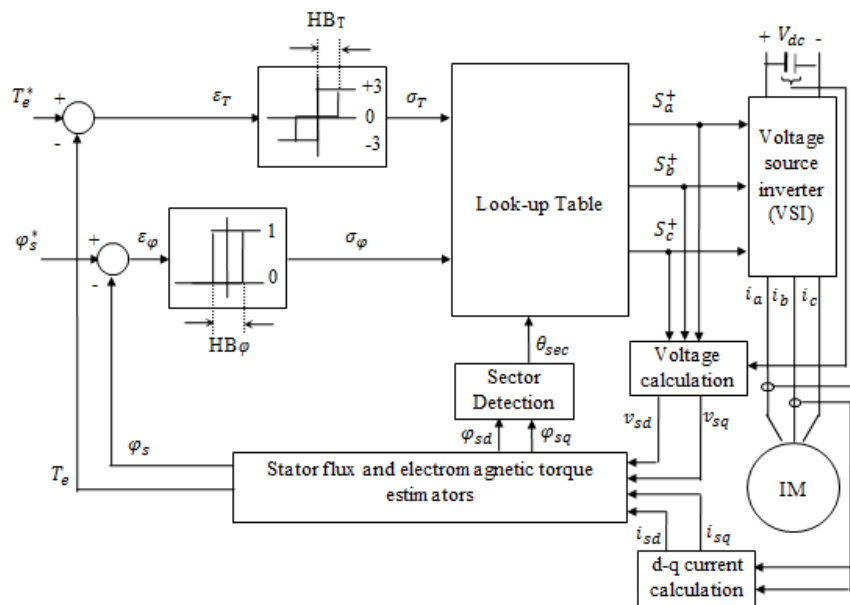

Figure 1. Structure of conventional hysteresis based Induction Machine drives Direct Torque Control (DTC) [1]

2.1. Voltage Source Inverter (VSI)

Figure 2 shows a simplified circuit of three-phase voltage source inverters (VSI). The three-phase VSI is connected to the wye-winding of an induction machine. Note that, the upper and lower switches for every phase of simplified VSI can be represented by a toggle switch since the switching of upper and lower IGBTs are complementary to each other. This means the switching state of each phase, i.e. S_a^+ , S_b^+ or S_c^+ equals to 1 when the upper switch of the leg is ON and the lower switch is OFF, otherwise, the switching state equals to 0.

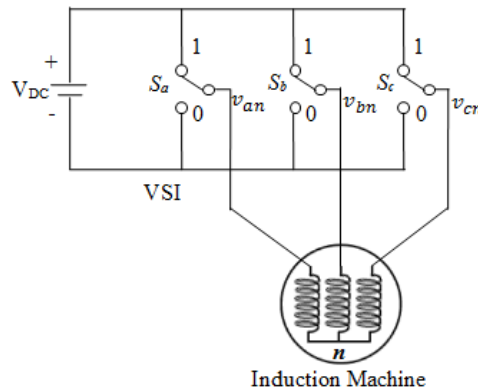

Figure 2. Three-Phase Voltage Source Inverter a Simplified Circuit

The combination of switching states in the VSI can provide eight possible switch configurations, which define the eight different voltage space vectors.

$$\bar{v}_{sk,n} = \frac{2}{3} V_{DC} (S_a^+ + a S_b^+ + a^2 S_c^+) \tag{1}$$

where $a = e^{j2\pi/3}$, $k = L$ or Z and $n = 0,1,2, \dots 7$.

Figure 3 shows eight possible space vectors drawn based on (1). Note that, the corresponded switching states for each voltage are given in the square bracket, i.e. $[S_a^+ S_b^+ S_c^+]$.

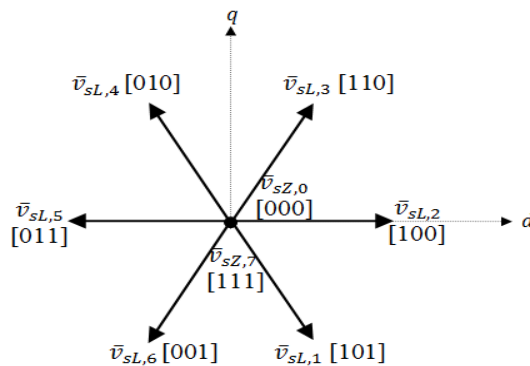

Figure 3. Voltage space vectors of a Three-phase inverter with the corresponded switching states

2.2. Estimators for Stator Flux and Torque

From the DTC structure shown in Figure 1, the estimators of stator flux and torque can be modelled using following equations.

The stator voltage equation can rearranged to form a pure integrator for estimating the flux as given in (2):

$$\bar{\varphi}_s = \int (\bar{v}_{sk} - \bar{i}_s \cdot R_s) dt \tag{2}$$

The estimation of stator flux using (2) can be split into the estimation of d - and q - axis of stator flux, as follows.

$$\varphi_{sd} = \int (v_{sd} - i_{sd} \cdot R_s) dt \quad (3)$$

$$\varphi_{sq} = \int (v_{sq} - i_{sq} \cdot R_s) dt \quad (4)$$

where the components of stator voltage and stator current can be simply calculated using the following equations,

$$i_{sd} = i_a \quad (5)$$

$$i_{sq} = \frac{(i_a + 2i_b)}{\sqrt{3}} \quad (6)$$

$$v_{sd} = \frac{1}{3} V_{DC} (2S_a^+ - S_b^+ - S_c^+) \quad (7)$$

$$v_{sq} = \frac{1}{\sqrt{3}} V_{DC} (S_b^+ - S_c^+) \quad (8)$$

where i_a and i_b are phase currents, S_a^+ , S_b^+ and S_c^+ are switching status, and VDC is input voltage of inverter. Note that the output of switching status can be either 1 or 0, as described above.

However, the estimation based on the voltage model has an initial drift problem due to existence of noise and DC offset in the current measurement [2]. To overcome this problem, the pure integration with a low-pass filter can be applied for minimizing the problem. By providing precise estimation of stator flux, this in turns will provide proper estimation of torque.

The electromagnetic torque equation can be rewritten into another form by considering the stator flux terms and referring to the stator stationary reference frame. Hence, this yields:

$$T_e = \frac{3}{2} P (\varphi_{sd} i_{sq} - \varphi_{sq} i_{sd}) \quad (9)$$

Taking the calculated flux and current components in (3) to (6) while Equation (9) can be used to estimate the torque in DTC drive system.

2.3. Look-up Table

Table 1 shows a look-up table for selecting voltage vectors in controlling the stator flux and the torque. In the table, the voltage vectors are represented by their switching states, as given in Figure 3. The selection of vectors is determined by the error statuses and flux sector.

2.4. Effect of Hysteresis Band on the Switching Frequency of DTC

The bandwidth of the hysteresis controller used to regulate the flux and torque in the DTC scheme influence the overall performance of DTC such as the current harmonics, torque ripple, switching frequency [3]. The switching frequency of the DTC varies with the operating condition such as the hysteresis bandwidth, stator flux, rotor flux, stator voltage, and rotor speed [4]. The switching frequency is mainly affected by the bandwidth of the torque hysteresis controller. The prefixed bandwidths of torque hysteresis controller have to be set according to the worst case condition. The worst case is at the lower or high speed operation where the reverse voltage vector should not be selected in a steady state operation as mention in previous section. Another worst case situation is to ensure the switching frequency does not exceed its limit in which is decided by the thermal restriction value of the power switching device (such as IGBT in this case).

In order to observe and analysis the effect using hysteresis based controller to regulate flux and torque, the DTC scheme was simulated with varying bandwidth from 1% to 25 % for both flux and torque. The flux is set to its rated flux value and torque is set to 1.1Nm. The rotor speed is set 120 rad/s for high speed, 80 rad/s for medium speed, and 40 rad/s for low speed [5]. The switching frequency of the power switches is computed and plotted in three dimensional graphs as shown in Figure 4. These graphs shows that the switching frequency is

mainly affected by the torque based hysteresis controller compare to the flux. The gradient (increment) of switching frequency is greater in the axis of torque hysteresis band compare to the flux hysteresis band. There is also another observation can be made where the switching frequency is also varies at different operation condition of motor speed. This variation is caused difference in the torque slope in which varies with operating speed. As a result, the time interval (or frequency) taken by torque estimation to reach upper and lower torque band will varies inversely proportional (is proportional) to the torque slope. Since the selection of suitable voltage vector is determined by torque demand signal (either increment or decrement), the switching frequency of inverter (IGBT) will be directly proportional to the frequency of torque estimation ripple.

Table 1. Look-up Table for Selecting Voltage Vectors

Stator flux error status, σ_ϕ	Torque error status, σ_T	Sector I	Sector II	Sector III	Sector IV	Sector V	Sector VI
1	+3	$\vec{v}_{sL,2}$ [100]	$\vec{v}_{sL,3}$ [110]	$\vec{v}_{sL,4}$ [010]	$\vec{v}_{sL,5}$ [011]	$\vec{v}_{sL,6}$ [001]	$\vec{v}_{sL,1}$ [101]
	0	$\vec{v}_{sZ,0}$ [000]	$\vec{v}_{sZ,7}$ [111]	$\vec{v}_{sZ,7}$ [111]	$\vec{v}_{sZ,0}$ [000]	$\vec{v}_{sZ,0}$ [000]	$\vec{v}_{sZ,7}$ [111]
	-3	$\vec{v}_{sL,6}$ [001]	$\vec{v}_{sL,1}$ [101]	$\vec{v}_{sL,2}$ [100]	$\vec{v}_{sL,3}$ [110]	$\vec{v}_{sL,4}$ [010]	$\vec{v}_{sL,5}$ [011]
0	+3	$\vec{v}_{sL,3}$ [110]	$\vec{v}_{sL,4}$ [010]	$\vec{v}_{sL,5}$ [011]	$\vec{v}_{sL,6}$ [001]	$\vec{v}_{sL,1}$ [101]	$\vec{v}_{sL,2}$ [100]
	0	$\vec{v}_{sZ,7}$ [111]	$\vec{v}_{sZ,0}$ [000]	$\vec{v}_{sZ,0}$ [000]	$\vec{v}_{sZ,7}$ [111]	$\vec{v}_{sZ,7}$ [111]	$\vec{v}_{sZ,0}$ [000]
	-3	$\vec{v}_{sL,5}$ [011]	$\vec{v}_{sL,6}$ [001]	$\vec{v}_{sL,1}$ [101]	$\vec{v}_{sL,2}$ [100]	$\vec{v}_{sL,3}$ [110]	$\vec{v}_{sL,4}$ [010]

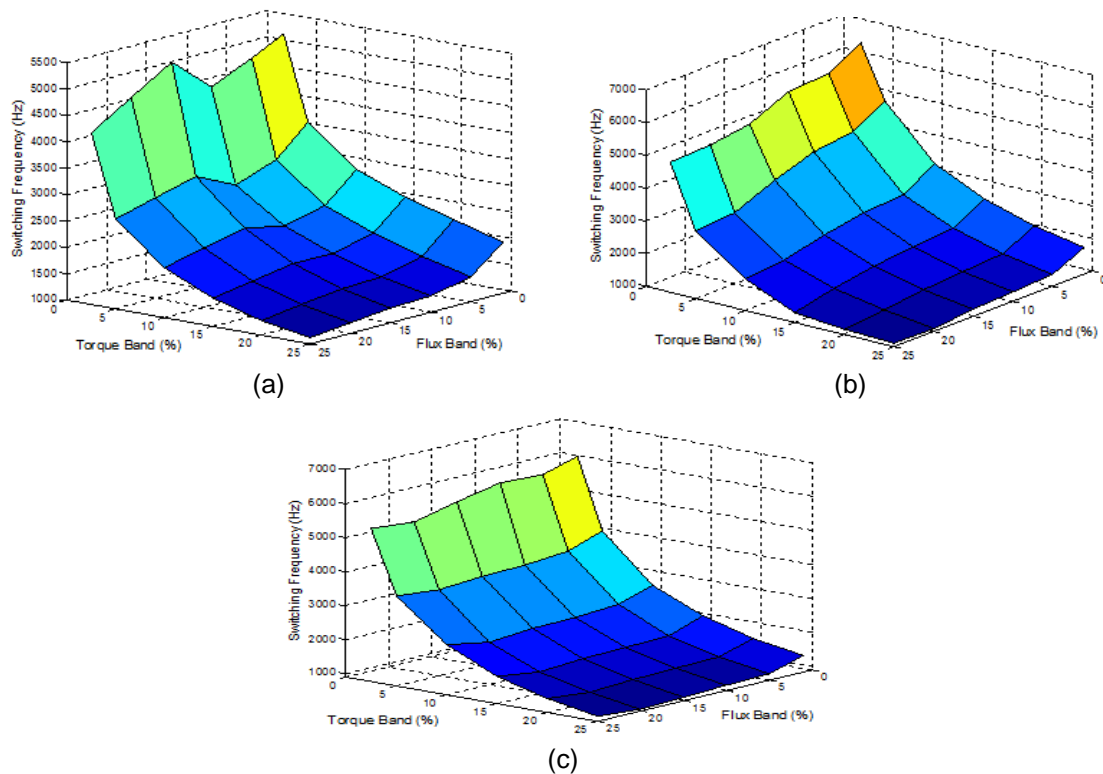

Figure 4. Switching Frequency Variation with torque hysteresis band and flux hysteresis band at operating speed of (a) 120 rad/s, (b) 80 rad/s, (c) 40 rad/s

3. Constant Switching Frequency Techniques

Several common techniques to achieve constant frequency will be explained in this section.

3.1. Predictive Control Based DTC

Predictive control has been subject by many researchers to achieve constant switching and thus reduce the torque ripple of induction motor drives. The basic structure of this predictive control is shown in Figure 5.

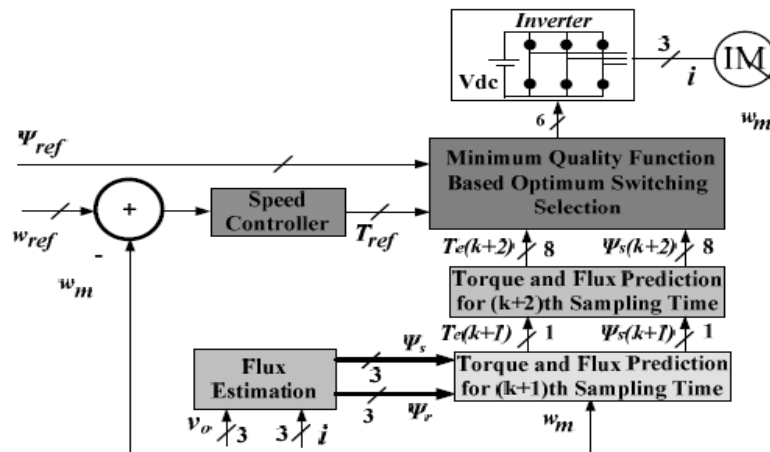

Figure 5. Basic structure of Predictive control [6]

This technique is claimed to be robust and easy to implement through the advancement in digital signal processing technologies. The predictive control algorithm utilized the motor's parameters such as stator resistance, rotor resistance, number of poles pair, self and mutual inductance to predict the stator flux, stator current and torque over the sampling time instant. This predicted variables used to choose the suitable switching vector in order to achieve lower torque ripple. This kind of algorithm is suitable for three phase 2-level DTC for conventional induction motor and also for double fed induction motor. The technique is more flexible and can be combined with other control strategy [7]. Since the weighting factor in cost function and optimization process for both torque and flux error need to be properly defined, the lack of theoretical guideline might be a big problem for this kind of control [8].

3.2. Fuzzy Logic Control Based DTC

The Fuzzy logic based DTC drive utilized the set of predetermined rules to choose the suitable voltage vector and switching states for the voltage source inverter. The example of this Fuzzy controller is shown in Figure 6.

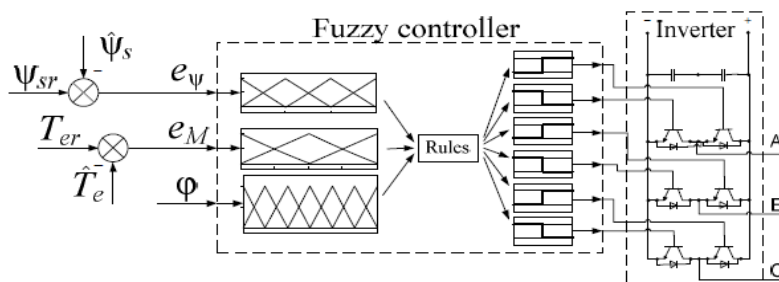

Figure 6. Structure of Fuzzy controller [8]

This controller used Mamdani model with defuzzification method to provide discrete output signal [9]. The rules in creates in relation with the membership function of both stator fluxs and toqeu deviation. Other research combined the fuzzy logic with PI controller to achieved better torque control of DTC drive.

Eventhough the result show promising and succesful result, this kind of techniques have their own drawbacks such as difficulties in setting up the membership function due to it large subjectivity and blindness. In order to increase the controller accuracy, complexcity of the system is increased. The accuracy also depends on the number of trial in order to find the proper fuzzy rules.

3.3. SVM Based DTC

The SVM method is known for its constant switching frequency and also reduction switching combination (reduce switching losses). The SVM method is combined with DTC scheme by utilizing the proper PI controller to generate the reference voltage vector signal of SVM method as shown in Figure 7. The controller calculate the suitable voltage vector and follow by the sapce vector modulation technique in order to generate switching signal for the three phase inverter or five phase inverter [10]. It also suitable for open end winding application as in [11]. The utilization of space vector modulator are the main charateristic the differetiate between classical DTC and SVM based DTC.

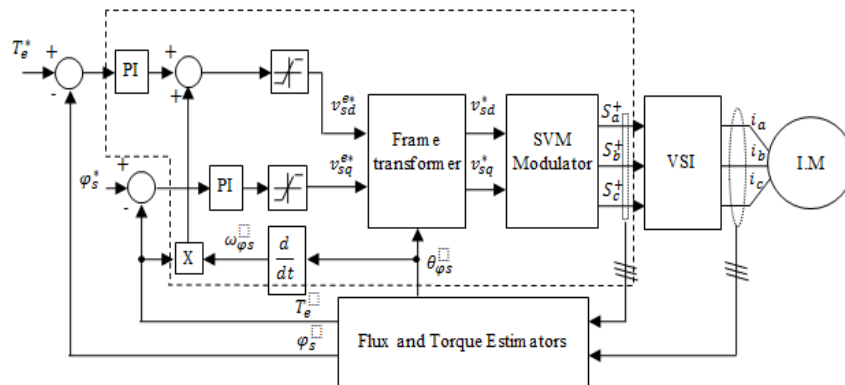

Figure 7. Structure of DTC-SVM [12]

Unlike hysteresis based DTC, the DTC-SVM eliminates the use of look-up table and hysteresis comparators. The SVM modulator requires an input reference of voltage vector (v_s^*) which is determined by torque and flux demands. This technique uses a pair of PI controller to estimate the reference of voltage vector, i.e. d- and q-axis components of the reference of voltage vector referred to the excitation reference frame (v_{sd}^{e*} and v_{sq}^{e*}). Specifically, the DC quantities of v_{sd}^{e*} and v_{sq}^{e*} are determined by the errors of flux and torque via their respective PI controllers. A frame transformation is required to transform the excitation reference frame of the voltage components into the stator stationary reference frame, i.e. v_{sd}^* and v_{sq}^* . The estimation of reference voltage is synthesized in the modulator to produce appropriate of switching vectors to fulfil the torque and flux demands, i.e. T_e^* and ϕ_s^* . However the drawbacks of this techniques is related to frame transformation which required fast processor which is expensive. On top of that the used of PI controller need to be properly tune in order to achieve its optimum performance.

3.4. Constant Frequency Torque Control

The CFTC method uses a PI controller and simple carrier wave to provide constant switching and regulate the torque around the reference value with minimized torque ripple compare to the convention DTC scheme. The CFTC controller method retains the simplicity factor of the DTC scheme. The CFTC method was introduced in the conventional DTC scheme with 2-level inverter where CFTC method shows significant improvements.

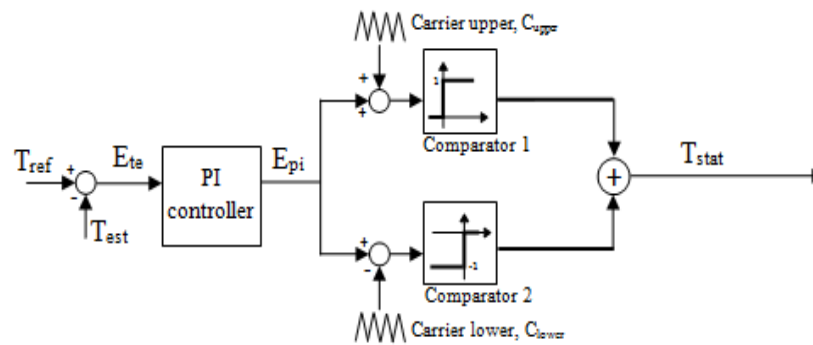

Figure 8. The basic structure of CFTC for conventional 2-level DTC scheme

The CFTC method was proposed by [13] and the basic structure of CFTC as shown in Figure 8. This method basically contains two triangular wave generator and proportional integral (PI) controller. The triangular waveforms are used as a carrier waveform to provide constant switching frequency of the torque error status in which resembles the carrier frequency. The PI controller is used to control and regulate the slope of the torque error signal where it should be smaller than the carrier signal slope. The CFTC method produce conventional DTC equivalent torque error status in which 1 for positive torque, 0 for reduce torque, and -1 for negative torque.

$$q(t) = \begin{cases} 1, & \text{for } C_{\text{upper}} \leq E_{\text{pi}} \\ 0, & \text{for } C_{\text{lower}} \leq E_{\text{pi}} < C_{\text{upper}} \\ -1, & \text{for } C_{\text{lower}} \geq E_{\text{pi}} \end{cases} \quad (10)$$

The Equation (10) was derived from the CFTC block to produce torque error status, $q(t)$ from the triangular carrier waveform and compensated torque error signal, E_{pi} .

4. Conclusion

This paper has reviewed several techniques used by the researcher to achieved the constant switching frequencies for Direct Torque Control (DTC) fed voltage source inverter motor drives. Overview of each techniques are elaborated in term of advantages and disadvantages. The propose DTC schemes has proven able to improve the Induction Motor drive performance in terms of reducing torque ripple, however there are still limitation that need to be solved.

Acknowledgements

This work is supported by Kementerian Pendidikan Malaysia and Universiti Teknikal Malaysia Melaka through research grants of FRGS/2/2013/TK02/UTEM/02/2-F00168.

References

- [1] Takahashi I & Noguchi T. A New Quick-Response and High-Efficiency Control Strategy of an Induction Motor. *IEEE Transactions on Industry Application*.1986; IA-22: 820-827
- [2] Bird IG, Zelaya de La Parra H. *Practical evaluation of two stator flux estimation techniques for high performance direct torque control*. Sixth International Conference on Power Electronics and Variable Speed Drives. 1996; 465-470.
- [3] Casadei D, Serra G & Tani A. Analytical investigation of torque and flux ripple in DTC schemes for induction motors. *23rd International Conference on Industrial Electronics, Control and Instrumentation, IECON 97*. 1997; 2: 552-556.
- [4] Kazmierkowski MP Kasproski AP. Improve direct torque and flux vector control of PWM inverter-fed motor drives, *IEEE Transactions on Industrial Electronics*.1995; 42(4): 344-350.

- [5] Ramahlingam S, Jidin AB, Raj LRLV, Said MA, Karim KA. *Improved performance of DTC for 5-phase induction machine using open-end topology*. IEEE Conference on Energy Conversion (CENCON). 2014; 195-200.
- [6] Uddin M, Mekhilef S, Nakaoka M, Rivera M. *Model predictive control of induction motor with delay time compensation: An experimental assessment*. IEEE Applied Power Electronics Conference and Exposition (APEC). 2015: 543-548
- [7] Zhang Y, Wang Q, Liu W. *Direct Torque Control Strategy of Induction motors Based on Predictive Control and Synthetic Vector Duty Ratio Control*. International Conference on Artificial Intelligence and Computational Intelligence. 2010: 97-101
- [8] Lisauskas S, Udris D, Uznys D. *Direct Torque Control of Induction Drive Using Fuzzy Controller*. *Elektronika ir Elektrotechnika*, 2013; 19(5): 13-16.
- [9] N Mahendran N, Gurusamy G. *Reduction of torque and speed pulsation in direct torque control of large induction motor using fuzzy logic controller*. *European Journal of Scientific Research*. 2011; 4(48): 559–566.
- [10] Raj LRLV, Jidin A, Wan CWMFC, Zalani M, Karim KA, Goh WY, Jopri, MH. *Improved performance of DTC of five-phase induction machines*. IEEE 7th International Power Engineering and Optimization Conference (PEOCO). 2013; 613-618.
- [11] Rahim K, Jidin A, Patkar F, Jamil MLM, Ahmadi MZRZ, Karim KA. *A dual mode DTC of open-end winding induction motor drive with reduced torque ripple*. IEEE Conference on Energy Conversion (CENCON). 2014: 106-111, 2014
- [12] Lasca C, Boldea I, Blaabjerg F. *A modified direct torque control for induction motor sensorless drive*. *IEEE Transactions on Industry Applications*. 2000; 36: 122-130.
- [13] Idris NRN & Yatim AHM. *Direct torque control of induction machines with constant switching frequency and reduced torque ripple*. *IEEE Transactions on Industrial Electronics*. 2004: 51: 758-767.