

# Theoretical Analysis of Gap Coupled Microstrip Patch Antenna

Akanksha Gupta<sup>\*1</sup>, D K Srivastava<sup>2</sup>, J.P. Saini<sup>3</sup>

<sup>1</sup>Department of Electronics and Communication Engineering, Bundelkhand University Jhansi, INDIA

<sup>2,3</sup>Department of Electronics and Communication Engineering, BIET Jhansi, INDIA

\*Corresponding author, e-mail: akku.gupta6@gmail.com

## Abstract

When a patch is placed close to the fed patch, get excited due to parasitic coupling between the two elements. This proposed work presents theoretical analysis of rectangular gap coupled microstrip patch antenna (R-GCMSA) using circuit concept model, and the effect of gap( $g$ ), feed width( $W_f$ ), and feed length on performance of the impedance bandwidth is also studied, it is observe as the gap between the parasitic element is increased resonant frequency shifted towards the parasitic patch resonant frequency for broadening the impedance bandwidth. The maximum impedance bandwidth for the proposed antenna design is 12.7% in the frequency range of 3.24-3.7GHz measured, with rectangular shape ground plane size  $60 \times 30 \text{m.m}^2$  the highest directivity achieved is 4dBi. The proposed design is simple in structure and compact in size, proposed design is simulated on IE3D Microwave simulator, the simulated result is in good agreement with obtained theoretical and measured results.

**Keywords:** Theoretical Analysis, R-GCMSA, RMSA

**Copyright © 2017 Institute of Advanced Engineering and Science. All rights reserved.**

## 1. Introduction

Rapid growth of compact wireless system demand broadband antenna's for satellite, medical and wireless communication applications, Many researchers make efforts to design broadband antenna's and the research is still carried out, an exhaustive list of these design is monopole antenna, printed monopole, shorting pin loaded, defected ground plane, stacked MSA, U-shape, H-shape, EE-shape, slot cut, direct coupled antenna, UWB antenna [1-7]. In recent year many researcher reported gap coupled designs using rectangular shape, K.P.ray design compact gap coupled design by splitting the RMSA in to smaller elements [8], Binod kumar kanaujia present angular ring gap coupled antenna for dual band operation [9], J.A. ansari presents gap coupled disk and stacked annular ring microstrip antenna with impedance bandwidth 10.89% [10]. Ashish Asthana present analysis of asymmetric gap coupled microstrip antenna [11], A.K. Gautam present varactor loaded gap coupled design with 5% instantaneous bandwidth [12] P. kumar presents the literature review to improve the bandwidth by gap coupling [13], J.A. Ansari again reported disk patch antenna with parasitic element in single layer as well as two layer structures [14], Pratigya mathur present non-radiating Edge Gap Coupled Capsule-Shaped and nose-shaped microstrip antennas design [15]. In the above reported structures they have excite the antenna using probe feed due to which spurious radiation occurs.[16],and the bandwidth is not more than 10%. The proposed work improve the bandwidth using microstrip line feed, this feeding has interesting characteristic, such as simplicity in structure and ease in fabrication that reduce the impedance matching problem [17].

## 2. Proposed Antenna Design

In this proposed work rectangular patch is used due to its silent features such as frequency agility, feedline flexibility, beam scanning, and these geometries are separable in nature [16] by using rectangular patch an attempt has been made to improve the bandwidth of an antenna by the method of gap coupling, and microstrip line feed technique. If the resonance frequencies of these two parasitic patches are close to each other, then wide band operation can be obtained, because the bandwidth of an antenna depends on separation between the elements [13]. In this design the coupled element is called parasitic element and the fed

element is called as radiating element. To obtain the symmetrical pattern with the broadside direction identical parasitic patches are gap-coupled to both the radiating edges of the fed patch.

The geometrical configuration of the proposed antenna is shown in Figure 1(a,b) top view and side view of the proposed design. The size of the proposed design ( $L_G$ ,  $W_G$ ) is  $60 \times 30 \text{ m.m.}^2$ , size of the fed element ( $L \times W$ ) is  $15 \times 20 \text{ m.m.}^2$  and size of the parasitic elements ( $L_P \times W$ ) is  $15 \times 20 \text{ m.m.}^2$  the antenna is designed on glass epoxy substrate of height ( $h$ ) 1.6m.m. and dielectric constant 4.2, microstrip line feed is given to the centre element of length 1m.m. and width 5m.m.

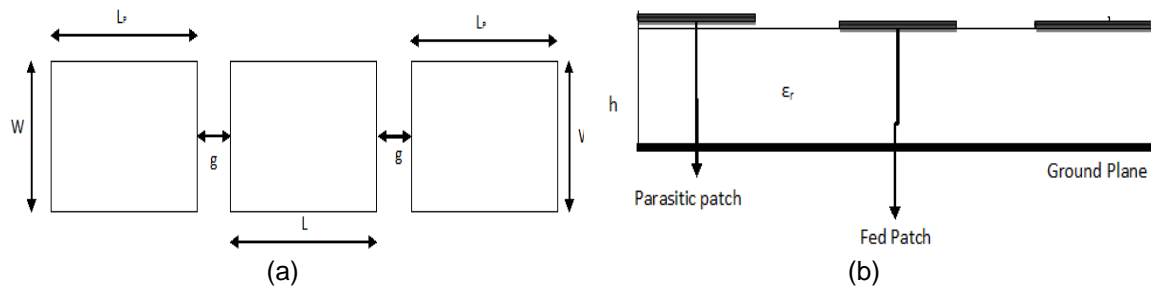

Figure 1. Geometry of the proposed single layer patch antenna. (a) Top view of proposed antenna. (b) Side view of proposed antenna

The design parameters of proposed design is shown in Table 1.

Table 1. Design Parameters of Proposed Design

Material	Glass Epoxy
Substrate height( $h$ )	1.6m.m.
Substrate dielectric constant( $\epsilon_r$ )	4.2
Ground plane Length $L_G$	60m.m.
Ground plane width $W_G$	30m.m.
Fed patch length $L$	15m.m.
Fed patch Width $W$	20m.m.
Parasitic Patch length $L_P$	15m.m.
Parasitic Patch width $W$	20m.m.
Loss tangent	.0013
Gap between element ( $g$ )	5 m.m.
Length of Microstrip feed( $L_f$ )	1 m.m.
Width of microstrip feed ( $W_f$ )	5 m.m.
Feed coordinate( $x_0, y_0$ )	0, -10

### 3. Theoretical Analysis of R-GCMSA

Rectangular patch is considered as a parallel combination of R, L and C as shown in Figure 2 according to cavity model, the value of which are given as [12]

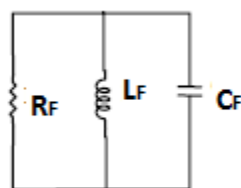

Figure 2. Equivalent circuit of Rectangular patch

$$C_F = \frac{\epsilon_{eff} \epsilon_0 L W \cos^{-2}(\pi y_0 / W)}{2h} \quad (1)$$

$$R_F = \frac{Q_r}{\omega C_F} \quad (2)$$

$$L_F = \frac{1}{\omega^2 C_F} \quad (3)$$

$$Q_r = \frac{c \sqrt{\epsilon_{eff}}}{8fh} \quad (4)$$

Where  $C_F, R_F, L_F$  is the fed rectangular patch antenna equivalent circuit parameters,  $Q_r$  is the total quality factor of the resonator.  $f$  is the resonant frequency of the fed patch,  $L$  and  $W$  are the length and width of the fed patch, and  $h$  is the thickness of the substrate material,  $y_0$  is the x co-ordinate of the feed point from the centre.

Here  $\omega = 2\pi f$  and  $\epsilon_{eff}$  = effective permittivity of the medium which is given as [14]

$$\epsilon_{eff} = \frac{\epsilon_r + 1}{2} + \frac{\epsilon_r - 1}{2} \left( 1 + 10h/W \right)^{-\frac{1}{2}} \quad (5)$$

The resonant  $f$  of the fed patch is calculated as [14]

$$f = \frac{c}{2L \sqrt{\epsilon_{eff}}} \quad (6)$$

Where  $c$  = velocity of light in free space.

The impedance of fed patch according to the equivalent circuit is given as

$$Z_F = \left( \frac{1}{\frac{1}{R_F} + \frac{1}{j\omega L_F} + j\omega C_F} \right) \quad (7)$$

Since the parasitic elements are excited through gap coupling by fed patch shown in Figure 3 the value of capacitance ( $C_2$ ), inductance ( $L_2$ ) and resistance ( $R_2$ ) for identical parasitic elements can be given as

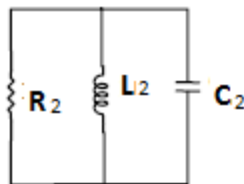

Figure 3. Equivalent circuit for Parasitic patch

$$C_2 = \epsilon_o \epsilon_r \frac{L_p W}{2h} \quad (8)$$

$$L_2 = \frac{1}{C_2 \omega^2} \quad (9)$$

$$R_2 = \frac{Q_r}{\omega^2 C_2} \quad (10)$$

The impedance of parasitic patch according to the equivalent circuit is given as:

$$Z_p = \left( \frac{1}{\frac{1}{R_2} + \frac{1}{j\omega L_2} + j\omega C_2} \right) \quad (11)$$

In this proposed work mutual coupling influences the radiation mechanism in constructive way, because the mutual coupling improve the bandwidth, the gap between the elements at the point of coupling can be considered as a  $\pi$ -network as shown in Figure 4 [13], the equivalent circuit of the gap coupled patch is shown in Figure 5, the gap between the patch is considered as the combination of plate capacitance ( $C_p$ ) and gap capacitance  $C_g$ .

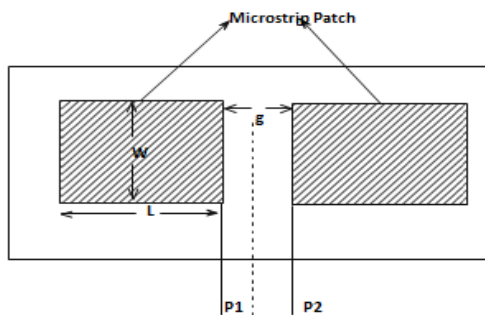

Figure 4. Gap Coupled Patch

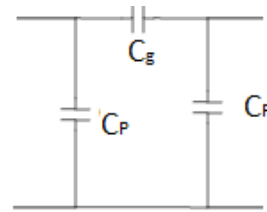

Figure 5. Equivalent circuit for gap

The expression for gap capacitance  $C_g$  and plate capacitances  $C_p$  of the microstrip antenna can be calculated as [11]

$$C_g = .5hQ_1 \times \exp\left(-1.86 \times \frac{g}{h}\right) \times \left[ 1 + 4.09 \times \left\{ 1 - \exp\left(0.785 \sqrt{\frac{h}{W_p}}\right) \right\} \right] \quad C_p = C_L \left( \frac{Q_2 + Q_3}{Q_2 + 1} \right) \quad (13)$$

$$C_L = \Delta_l \frac{\sqrt{\epsilon_{eff}}}{Z_M} \times c \quad (14)$$

$$Z_M = \frac{120\pi}{\frac{W}{h} + 2.42 - \frac{.44h}{W} + \left(1 - \frac{h}{W}\right)^2} \quad \text{for } W/h \geq 1 \quad (15)$$

$Z_M$  is the characteristic impedance of patch,  $Q_1$ ,  $Q_2$  and  $Q_3$  defined as [11].  $C_L$  is the terminal capacitance of the open circuited conductor, and  $g$  is the separation between fed and parasitic patch.

**4. Microstrip Line Feed Analysis**

Micro strip line is considered as the parallel combination of strip inductance  $L_L$  and the strip capacitance  $C_L$  as shown in Figure 6 is calculated as [1]

$$\begin{aligned}
 C_L &= \sqrt{wW_f}(130\log(w/W_f) - 44) pF \\
 L_S &= h(40.5(w/W_f - 1) - 75\log(w/W_f) + \\
 &.2(w/W_f - 1)^2) nF
 \end{aligned}
 \tag{16}$$

Where  $W_f$  = width of the feed strip

The characteristic impedance of Microstrip line is considered as,

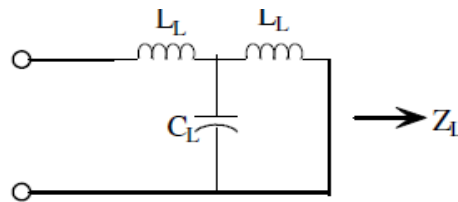

Figure 6. Equivalent circuit for Microstrip feed

$$Z_L = j\omega L_L + \frac{1}{j\omega C_L + \frac{1}{j\omega L_L}}
 \tag{17}$$

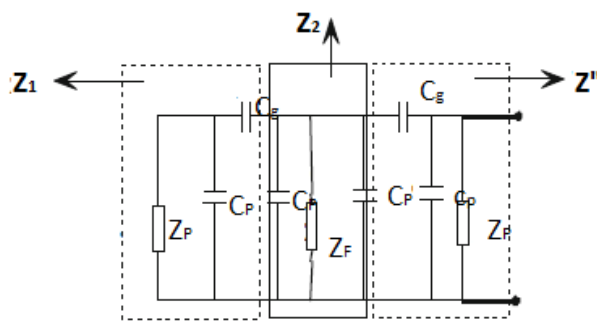

Figure 7. Equivalent circuit for proposed design

The equivalent circuit of the proposed design shown in Figure 7. The equivalent circuit is the combination of parasitic patch impedance ( $Z_P$ ), radiating patch impedance ( $Z_F$ ) and gap capacitances ( $C_P, C_g$ ). Now solving this circuit the total impedance can be given as:

$$Z_T = Z_{Even} + Z_{Odd}$$

$$Z_{Even} = \frac{Z_P Z_{F1}}{2(Z_{F1} + Z_C Z_P Z_{F1} + Z_P)} \quad (18)$$

$$Z_C = j\omega(2C_P)$$

$$Z_{Odd} = \frac{Z_P Z_{F1}}{2(Z_{F1} + Z_{C1} Z_P Z_{F1} + Z_P)} \quad (19)$$

$$Z_{C1} = j\omega(2C_g + C_P)$$

$$Z_{F1} = Z_F + Z_L$$

CP1 = CP2 because the size of two parasitic element is symmetrical and ZF is the impedance of fed patch as calculated above Equation (7). The Reflection coefficient of the antenna:

$$(\mu) = \frac{Z_C - Z_T}{Z_C + Z_T} \quad (20)$$

ZC is the characteristic impedance of the micro strip line feed (50Ω).

$$VSWR = \frac{1 + \mu}{1 - \mu} \quad (21)$$

$$\text{Return loss} = 10 \log \frac{1}{\mu^2}$$

Radiation Pattern: The radiation pattern of the rectangular patch can be calculated as follows [17-18]

$$E(\theta) = \frac{-jk_0 W_P V e^{-jk_0 r}}{\pi} \cos(kh \cos \theta) \times$$

$$\frac{\sin\left(\frac{k_0 W_P}{2} \sin \theta \sin \phi\right)}{k_0 W_P / 2 (\sin \theta \sin \phi)} \cos\left(\frac{k_0 L_P}{2} \sin \theta \sin \phi\right) \cos \phi \quad (22)$$

where  $0 \leq \theta \leq \pi/2$

$$E(\phi) = \frac{-jk_0 W_P V e^{-jk_0 r}}{\pi} \cos(kh \cos \theta) \times$$

$$\frac{\sin\left(\frac{k_0 W_P}{2} \sin \theta \sin \phi\right)}{\frac{k_0 W_P}{2} \sin \theta \sin \phi} \cos\left(\frac{k_0 L_P}{2} \sin \theta \sin \phi\right) \cos \phi \sin \phi$$

$$0 \leq \theta \leq \pi/2 \quad (23)$$

Where V is the radiating edge voltage, r is the distance of an arbitrary point:

$$k = k_0 \sqrt{\epsilon_{eff}}$$

$$k_0 = 2\pi/\lambda$$

$$\text{Gain} = \eta D$$

where D is the directivity of RMSA antenna is given as  $D = 4W^2\pi^2/I2\lambda^2$  and

$$I = \int_0^{\pi} \sin^2(k_0 w \cos \theta \frac{1}{2}) \tan^2 \theta \sin \theta d\theta \quad (24)$$

## 5. Result and Discussion

Figure 8(a,b) shows the fabricated and measured on network vector analyzer the antenna is tested on N9915A keysight technology vector analyzer. Figure 9 shows comparison between measured, simulated and theoretical results in the frequency range of 1-4GHz, there is a good agreement of bandwidth between the theoretical and measured results as shown in figure. Figure 10 and 11 shows the feed width and length variation from 2-5m.m. and it is analyzed when Wf is 1m.m. and Lf is 5m.m. best result is obtained, Figure 12 shows the variation of fed patch length (L) or the variation of gap (g) between parasitic and fed patch. The gap between the parasitic and fed patch is varied  $g = 1.5$  to 5m.m. proposed antenna is designed when fed patch length is 15m.m. and the gap is 5m.m. Figure 13 shows the maximum directivity obtained which is 4DBi. The radiation pattern (Elevation, Azimuth) of antenna at lowest (2.006GHz) and highest frequency (2.52GHz) is shown in Figure 14 and 15(a,b) the antenna radiate symmetrically in broadside direction.



Figure 8. Fabrication and measured result of proposed design

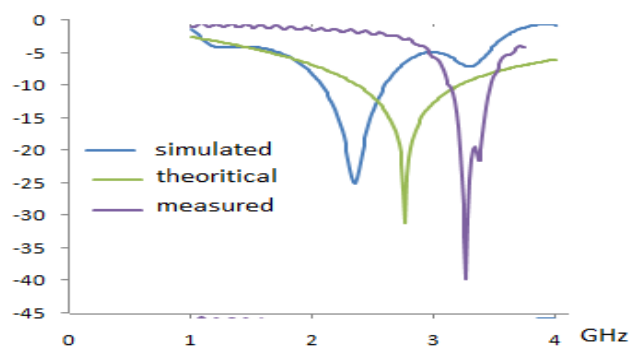

Figure 9. Return loss (simulated, theoretical and measured) result

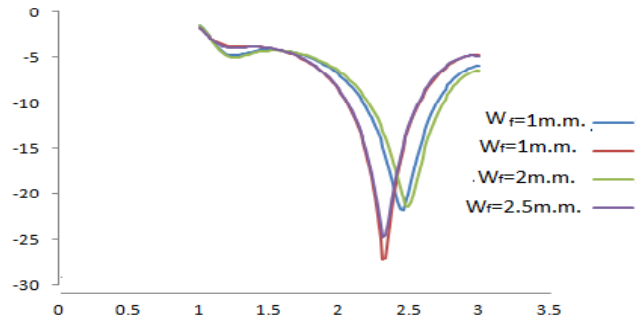

Figure 10. Simulated result of feed width variation

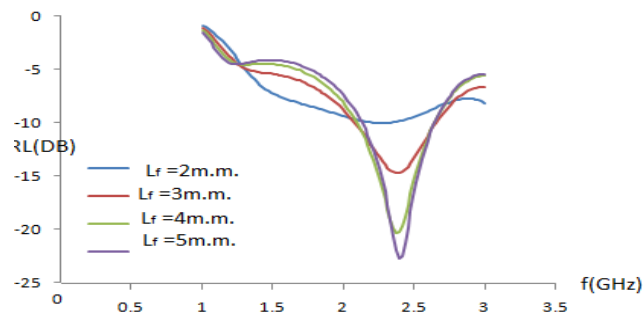

Figure 11. Simulated result of feed length variation

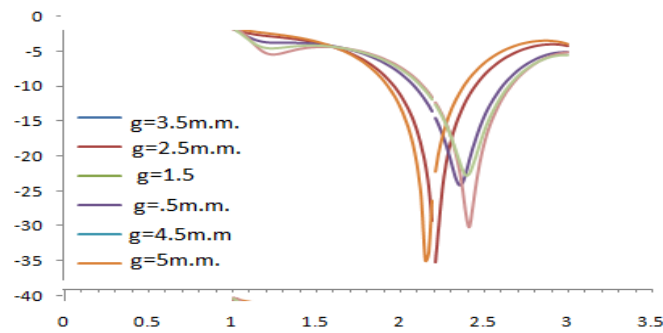

Figure 12. variation of gap with frequency

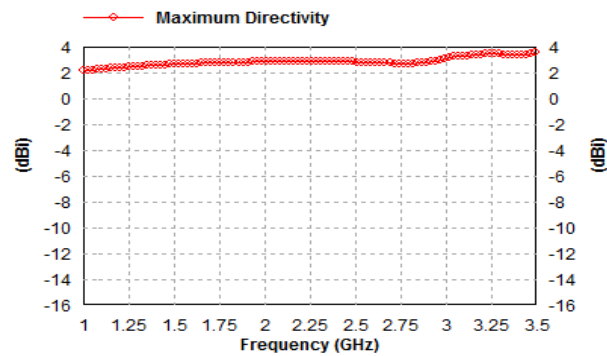

Figure 13. Directivity vs frequency



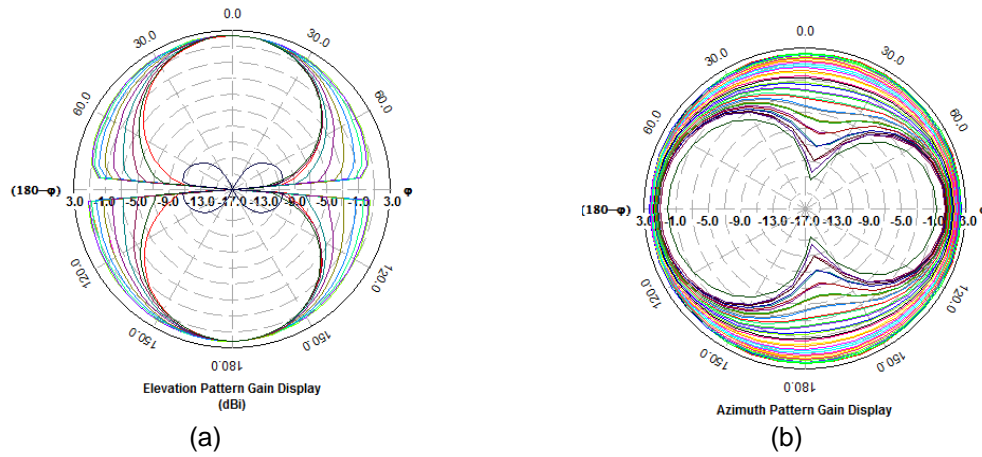

Figure 14. Elevation and Azimuth pattern of proposed design (f=2.006GHz)

The Elevation pattern is simulated when  $\theta = 00$  in xz plane and Azimuth pattern is calculated  $\phi = 900$  in xy plane. Figure 16 shows the maximum efficiency of proposed antenna which is 100%, Figure 17 (a,b) Shows the current distribution at 1.2GHz and 2.52GHz.

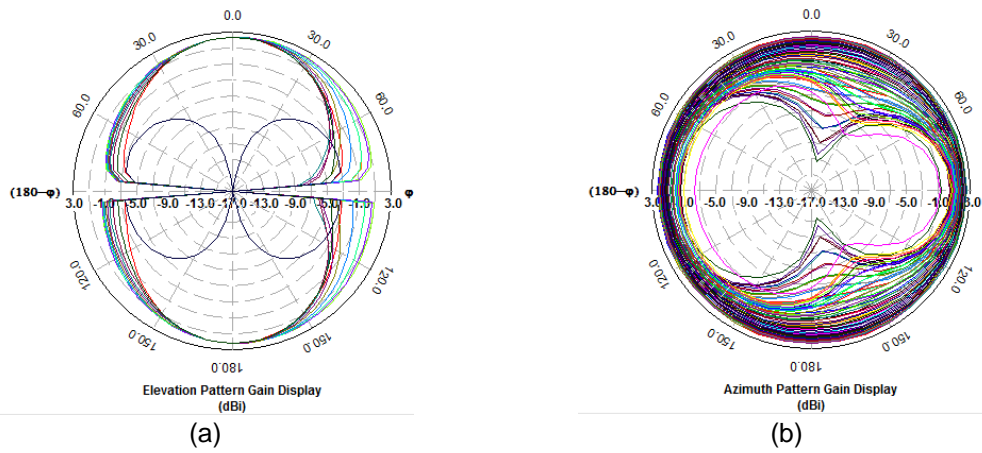

Figure 15(a,b). Elevation and Azimuth pattern of proposed design (f=2.006GHz)

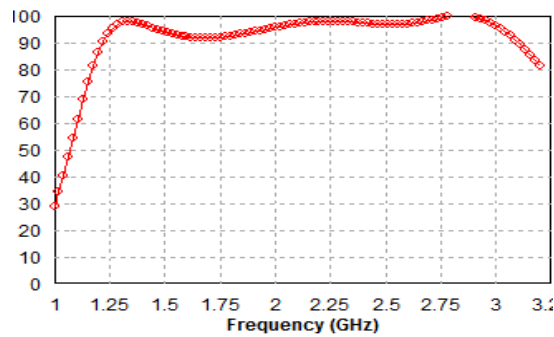

Figure 16. Maximum Efficiency of proposed design

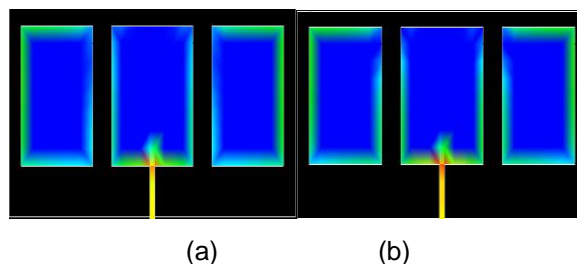

Figure 17. Current distribution at lowest (2.006GHz) and highest (2.52GHz) frequency

## 6. Conclusion

The theoretical analysis of gap coupled RMSA is presented in this communication. The selected antenna has a very compact size of (60 mm x 30 mm x 1.6 mm). The impedance bandwidth of the proposed antenna at -10 dB return loss is about 20% (theoretical) and 12% measured, which can easily cover the frequency bands of Wi-MAX (2.5–2.69GHz) WLAN (2.4–2.484)GHz. The antenna is simulated using IE3D, version of Zealand. There is a good agreement between simulated, theoretical and measured results.

Conflict of interest there is no conflict of interest regarding this paper publication.

## References

- [1] Ramesh Garg, *Microstrip lines and slot lines* second Edition, Artech house Boston, London 1996.
- [2] S. L. S. Yang, A. A. Kishk, and K. F. Lee, "Frequency Reconfigurable U-Slot Microstrip Patch Antenna," *IEEE Antennas Wireless Propag. Lett.* 2008; 7: 127-129.
- [3] T Jayanthi, M Sugadev, J Mohamed, Ismaeel, G Jegan. *Design and simulation of microstrip m-patch antenna with double layer,* IEEE Microwave conference. 2008; 8: 230-232.
- [4] D. Pozar and S. Targonski. "A shared-aperture dual-band dual-polarized microstrip array," *IEEE Trans. Antennas and Propag.* 49, (2001), 150 – 157.
- [5] Chandan kumar ghosh, Arabinda Roy, Susanta kumarparui. Elevated cpw-fed slotted microstrip antenna for ultra-wideband applications. *International journal of antenna and Propagation.* 2012.
- [6] Chun-KunWu and Kin-Lu Wong. Broadband microstrip antenna with directly coupled and parasitic patches. *Microwave Opt Technol Lett.* 22(1999)348-349.
- [7] M. T. Islam. "Broadband e-h shaped microstrip patch antenna for wireless systems" Progress In Electromagnetics Research. 98,(2009) 163–173.
- [8] K.P.Ray, V.Sevani, and R.K.Kulkarni. "Gap coupled rectangular microstrip antennas for dual and triple frequency operation". *Microwave Opt Technol Lett.* 4 (2007).
- [9] Binod kumar Kanaujia and Anil kumar singh. Analysis and design of gap coupled annular ring microstrip antenna. *International Journal of Antennas and Propagation.* (2008).
- [10] J.A.Ansari, N.P.Yadav, P.singh, and A.Mishra. "Analysis of Broadband operation of DiskPatch Antenna with parasitic Elements in single and two Layer Structures". *Microwave Opt Technol Lett.* 22 (2010); 140-147.
- [11] Ashish Asthana and Babu R. Vishvakarma. "Analysis of gap coupled microstrip antenna. " *Int. J. Electronics.* 88(2001), 707-718.
- [12] A.k.Gautam and B.R.Vishvakarma. "Analysis of varactor loaded active microstrip antenna" *Microwave Opt Technol Lett.* 49 (2006): 416-421.
- [13] P.kumar, G.singh. "Gap coupling a potential method for enhancing the bandwidth of microstrip antennas" *Advance computational Techniques in Electromagnetics.* 2012(2012) 1-5.
- [14] J. A. Ansari, N. P. Yadav, A. Mishra, Prabhakar Singh, Babau R. Vishvakarma. "Analysis of multilayer rectangular patch antenna for broadband operation". *Springer Science.* (2010).
- [15] Ramesh Garg, Prakash Bharti, Inder Bahl, Apisak Ittipiboon, *Microstrip Antenna Design Handbook* Artech house, Boston, London. (2001).
- [16] "Modeling and constructing the microstrip notch-loaded rectangular S-shaped patch antennas using L-strip feeding for multi-band frequency performances". *International Journal of Microwave Wireless Tech.* 8( )
- [17] Wood C. "Improved Bandwidth of Microstrip Antennas Using Parasitic Elements". *IEEE Proc. Microwave. Antennas Propagation.* 127; (1980) 231-234.
- [18] IE3D simulation software, Zealand, version9.03 2008.
- [19] Fabrication and testing BIET Jhansi.