

## Analysis of Transistor Open Fault Diagnosis for Shunt Active Power Filters

L. Benyettou\*, T. Benslimane

Laboratory of Electrical Engineering, University of M'sila, Algeria

\*Corresponding author, e-mail: benyettou\_letfi@yahoo.fr

### Abstract

*In this paper a transistor open-circuit fault diagnosis problem in two-level voltage inverter controlled shunt active power filter drives was discussed. Taking into consideration requirements of the contemporary monitoring drive systems original transistor fault diagnostic technique were proposed. Presented results were obtained by designed in PSIM software simulation model.*

**Keywords:** Analysis, transistor Open fault, Diagnostic, Inverter 2 levels, APF

**Copyright © 2017 Institute of Advanced Engineering and Science. All rights reserved.**

### 1. Introduction

Electric power static converters knew a remarkable development in terms of performance (commutation frequency and commutated powers) and structures (multilevel inverters and matrix converters). This was mainly due to the technological progress of power electronics components especially during the last decades.

Due to the extensible use of alternating current machines, DC-AC converters (inverters) became the most used static converters. In spite of that, these converters can be exposed to control or power faults. These faults must be detected rapidly to avoid the total destruction of static converter, which makes the preventive diagnostic necessary and indispensable.

The diagnostic is defined as the identification of probable cause of a system failure (s) using a logical reasoning based on inspection, control or test informations (indicative variables or faults indicators). It consists in resolving the revers problem of cause-effect relation (causality) by defining the effect through the observable symptoms.

The reliability of power electronic equipments becomes extremely important in general in industrial applications. The fault mode behaviour of static converters, protection and fault tolerant control of voltage source inverter systems has been covered in a large number of papers. Most of them are focused on induction motor drive applications.

D. Kastha and B. K. Bose considered various fault modes of a voltage source PWM inverter system for induction motor drive [1]. They have studied rectifier diode short circuit, inverter transistor base driver open and inverter transistor short-circuit conditions. However, they do not propose to reconfigure the inverter topology.

C. Thybo was interested in fault tolerant control of induction motor drive applications using analytical redundancy, providing solutions to most frequent occurring faults [2].

E. R. C. Da Silva and al investigated fault detection of open-switch damage in voltage source PWM motor drive systems [3]. They mainly focused on detection and identification of the power switch in which the fault has occurred. In another paper, they investigated the utilization of a two-leg based topology when one of the inverter legs is lost. Then the machine operates with only two stator windings [4]. They proposed to modify PWM control to allow continuous free operation of the drive.

More recently, E. R. C. Da Silva and al have studied fault tolerant active power filter system [5]. They proposed to reconfigure power converter and PWM control and examined a fault identification algorithm.

This present paper deals with open switch faults detection and localization in shunt active three-phase filter based on two level voltage source inverter controlled by current Hysteresis controllers. The proposed method is simple and reliable. It needs no more than active filter current sensors and display interface indicating the open faulty power switch.

The aim of the work, proposed in this frame, is to define faults indicators, that allow identifying and localizing the fault in two-level inverters used as parallel active power filters for varying non-linear loads. Finally, diagnostic system is designed based on analysis of different fault indicators evolution during each fault.

## 2. Principle of Parallel Active Filtering

Parallel Active power filters (PAPFs), also called shunt compensators, are connected in parallel to the power grid. They consist of static converters based on power semiconductors (inverter type structures) associated with a control device and adapted command. They can be considered as current sources that inject currents similar to identified harmonic currents at the network level. A PAPF can be of current source structure type or voltage source structure type, depending on the type of energy storage type, that achieved by an inductor or a capacitor [6]. The Figure 1 presents the two-level three-phase shunt active power filter connected to balanced power grid ( $v_{si}$  for  $i = \{1, 2, 3\}$ ) powering a three phase parallel-connected two diode rectifiers feeding variable series (R, L) loads. The active filter is composed, in each phase, of two voltage source H-bridge inverters ( $H_{ij}$ ,  $i=1,2,3$ ,  $j=1,2$ ) with 4 bidirectional switches (transistor + diode) for each one. The filter is connected to the power grid through inductive filter  $L_f$  for each phase. The output currents of shunt active filter are controlled to provide a similar waveform of identified reactive and harmonic currents generated by the non-linear load (diode rectifiers).

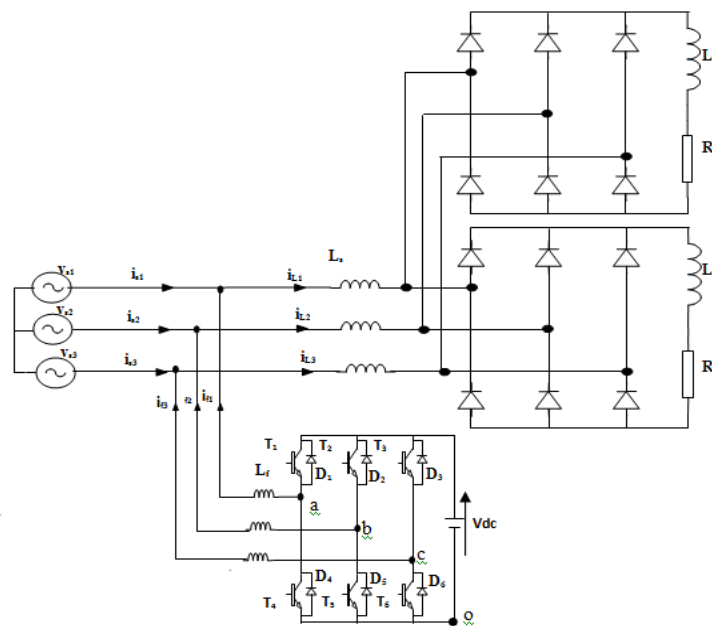

Figure 1. General structure of a parallel active power filter

## 3. Results of Simulation of the entire Power Grid-Nonlinear Load-PAPF based on 2-Level voltage Source Inverter in Healthy Condition

Figure 2 shows the three-phase main source voltage. It is supposed to be balanced and non-significantly affected by the current of polluting load. The latter is shown in Figure 3 and its harmonic spectrum is shown in Figure 4 for two different loads. There is the presence of harmonic components whose frequencies are 250 Hz, 350 Hz, 550 Hz, 650 Hz, 850 Hz, 950 Hz, ... . In other words, the harmonics of rank 5, 7, 11, 13, 17, 19, ... or  $h = 6K \pm 1$  with  $K = 1, 2, 3, 4, \dots$  are very remarkable. The current of phase 1 of the polluting load shows a total harmonic distortion (THD) variable (between 14 and 22.95%) according to the variation of DC load supplied by the polluting load (rectifiers). Figure 5 illustrates the waveforms of three-phase harmonic currents identified by the method of instantaneous real and imaginary powers

accompanied by currents injected by the parallel active filter and their mean values. It is observed that, for each phase, the identified harmonic current and the filter current are superimposed and almost symmetrical (average value calculated over one cycle of the mains voltage is almost nil). This led to have an almost sinusoidal mains phase current (Figure 6), where the harmonic components of order  $h = 6K \pm 1$  are significantly reduced (Figure 7), and the THD is reduced to less than 4%.

The PWM control reference voltages and the carrier voltage, for different values of the DC load, are shown in the Figure 8. It is clear that these periodic references change their forms depending on the variation of the identified harmonic current, but they maintain their symmetry.

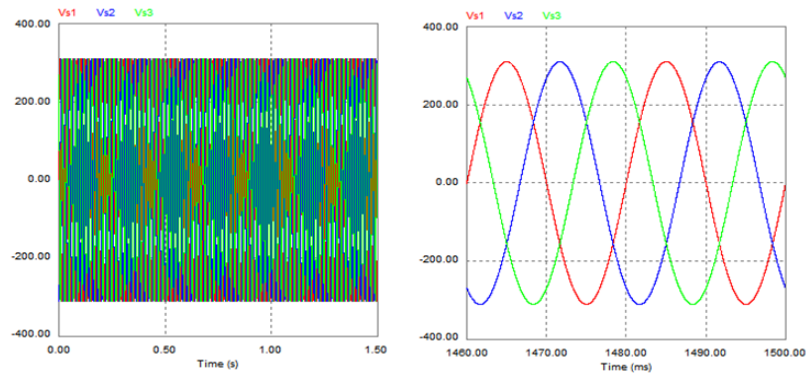

Figure 2. Three-phase voltage of power grid

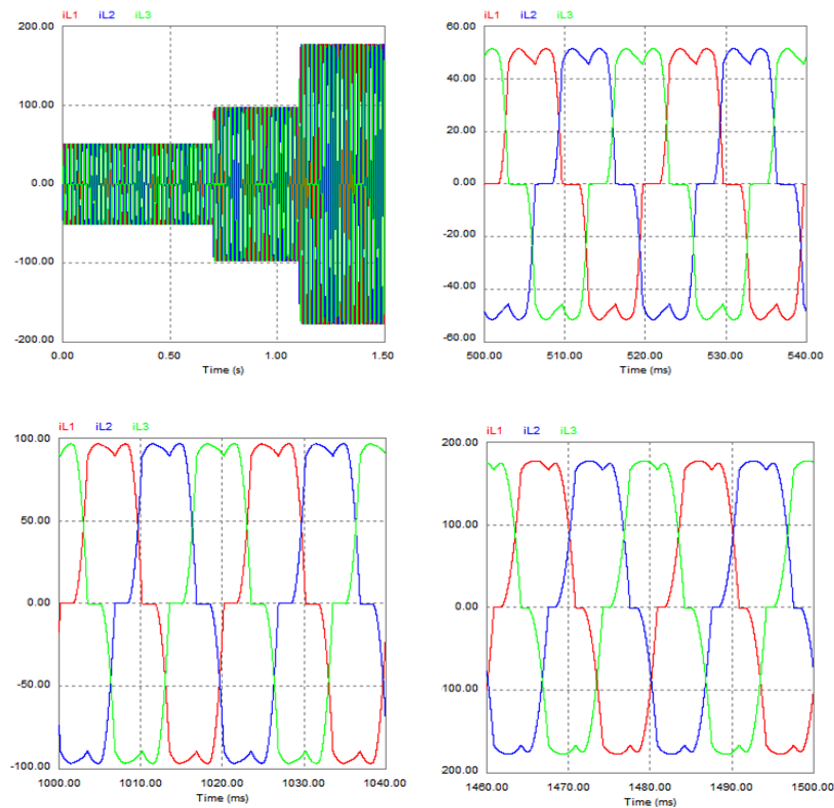

Figure 3. Three phase nonlinear load

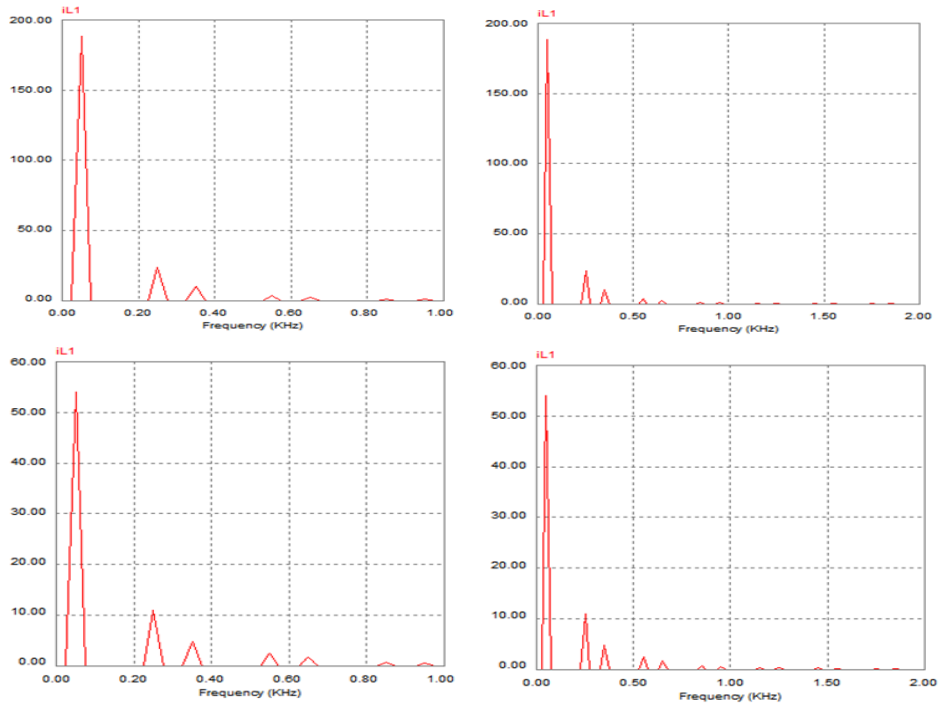

Figure 4. Spectral analysis of phase 1 of nonlinear load

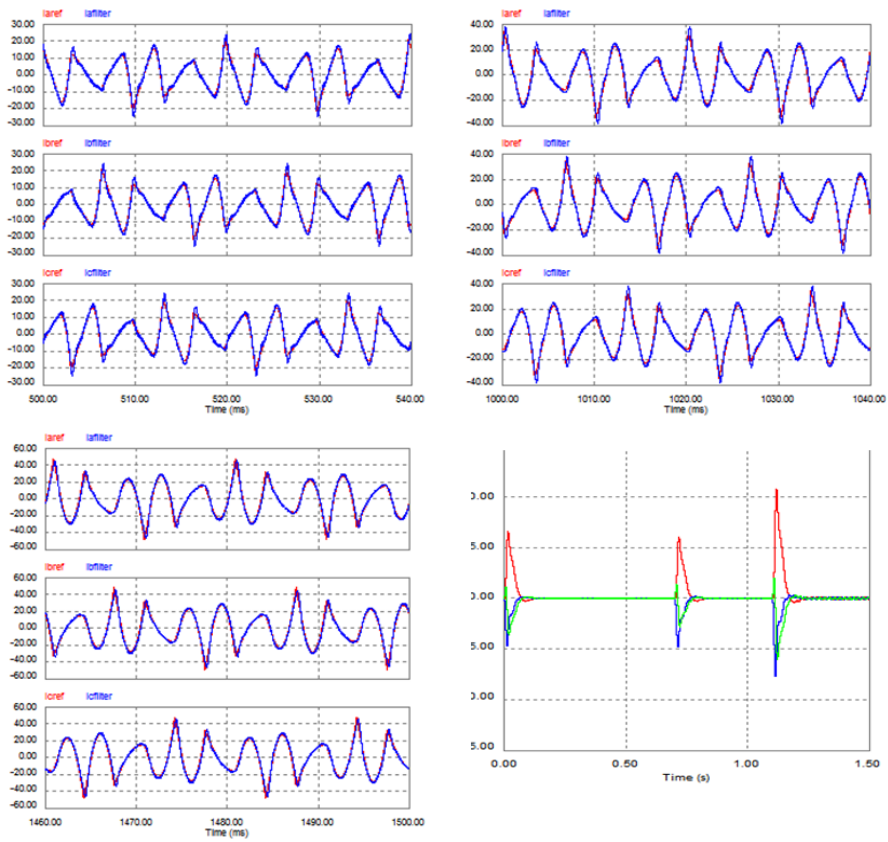

Figure 5. Identified harmonic currents and currents of PAPF based on two-level-voltage source inverter and their mean values

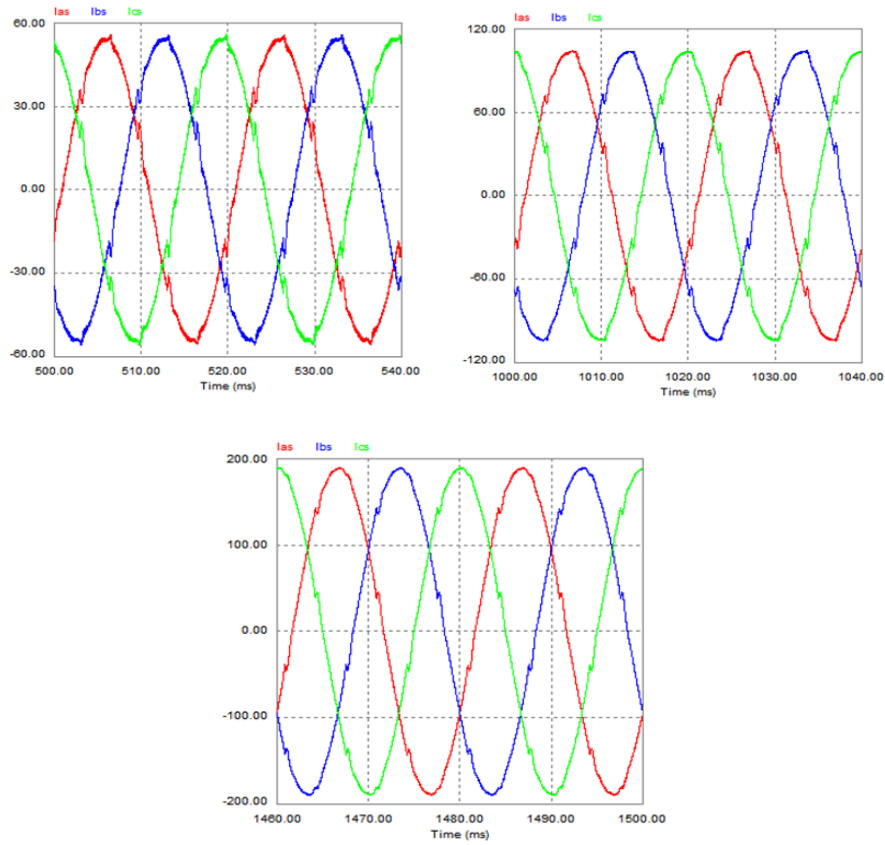

Figure 6. Three-phase power grid currents after filtering by a PAPF based on two-level voltage source inverter

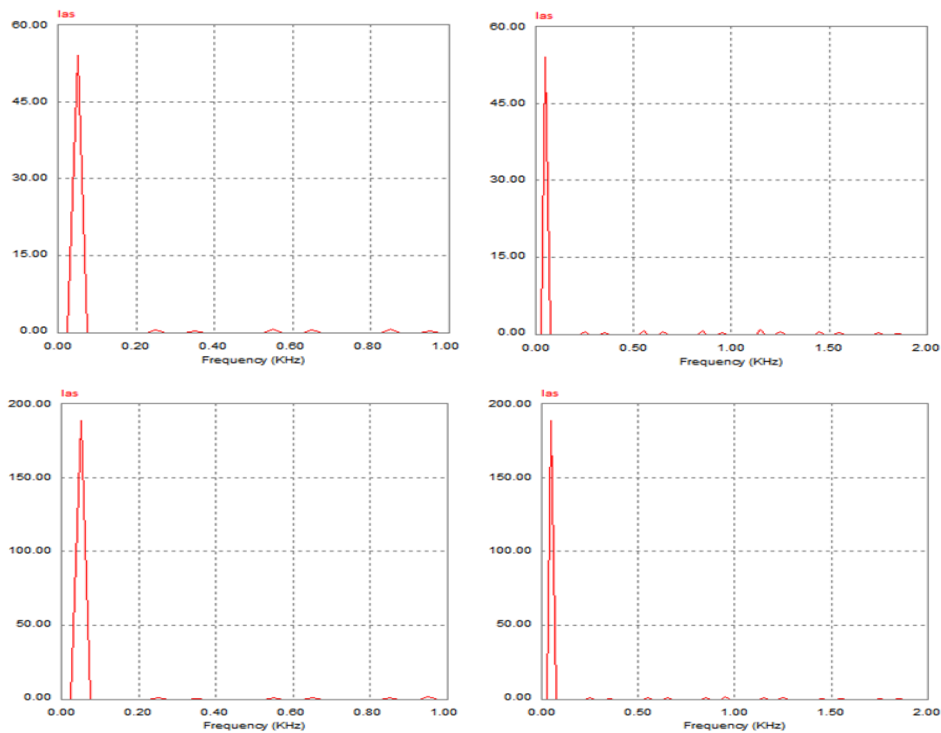

Figure 7. Spectral analysis of the phase 1 current of the grid after filtering by a PAPF based on two-level voltage source inverter

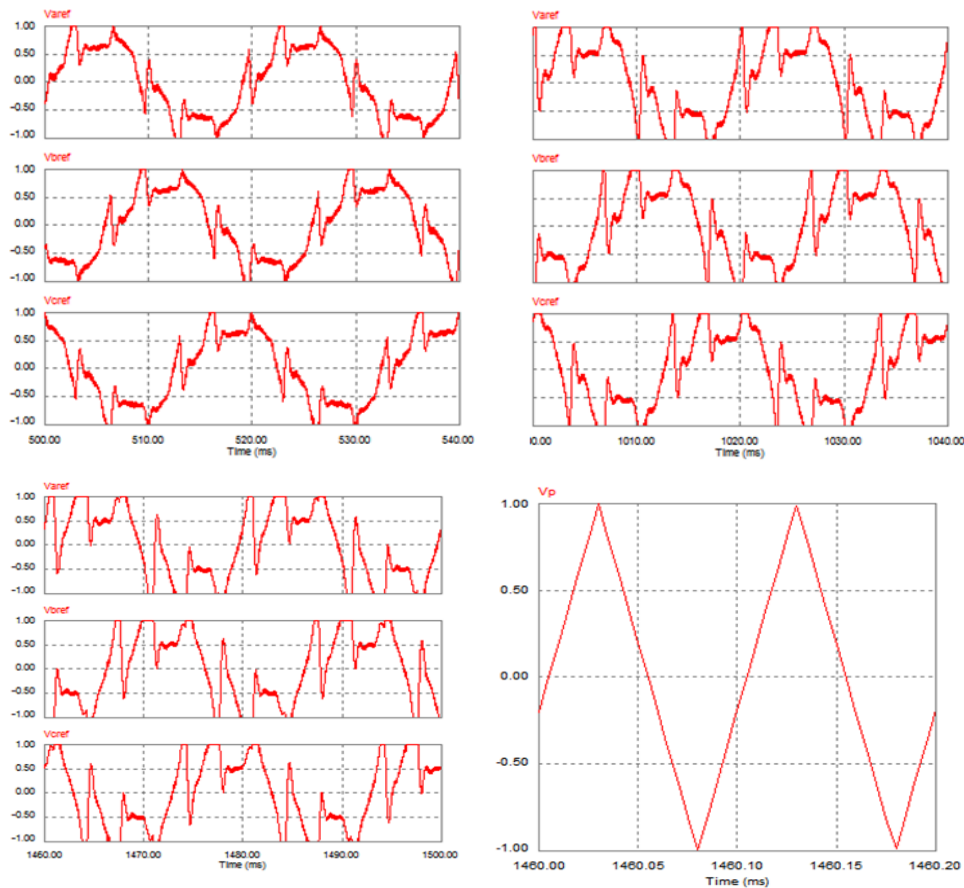

Figure 8. PWM control reference voltages and carrier for PAPF based on two-level voltage source inverter

#### 4. Analysis of Simulation Results of PAPF Based on 2-level Voltage Source Inverter in Fault Condition

To extract reliable indicators of faults, we shall analyze the behavior, in faulty mode, of the parallel active power filter based on two-level voltage source inverter. We proceed to simulate the system while maintaining, each time, one of the inverter transistors open and observe the evolution of different PAPF electrical quantities. In the end, an algorithm for open transistor fault detection will be designed.

1. If the faulty open transistor is one of the top transistors (T1, T2 and T3), the current of the phase connected to the arm with faulty transistor loses almost all the positive portion of its shape, while maintaining its periodic nature. The currents of the other phases lose a portion of their negative parts (Figure 9 and Figure 11). In other words, the current of the phase connected to the faulty arm has a negative DC component, while currents of the other phases have positive DC components (Figure 9 and Figure 11). This has a negative influence on PAPF compensation quality. The asymmetry of PAPF phase currents produces an asymmetric PWM control reference voltages, which influences the control of the 6 transistors of PAPF.

2. If the failed transistor is one of the low transistors (T4, T5 and T6), the current of the phase connected to the arm with faulty transistor loses almost all the negative portion of its shape, having a positive DC component, while maintaining its periodic nature. The currents of the other phases lose a portion of their positive parts, having negative DC components (Figure 10).

**4.1. Simulation Results for the Top of the Transistor 1 kept Open Arms (Open Fault T1)**

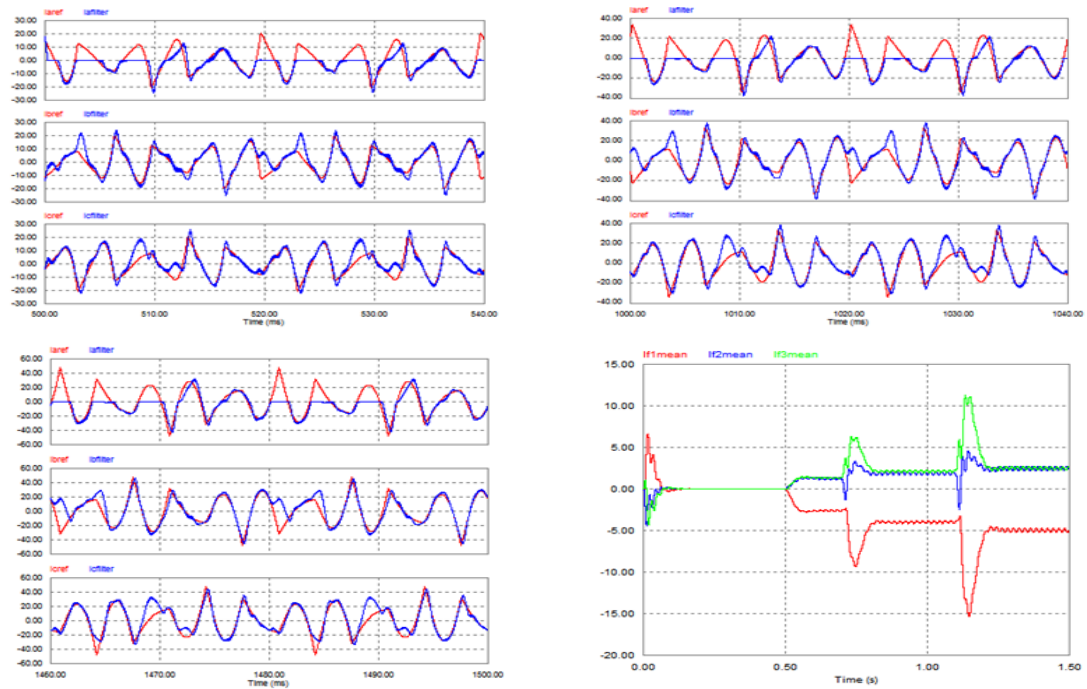

Figure 9. Harmonic currents identified by the method of real power and instantaneous imaginary and currents injected by the FAP based voltage inverter 2 levels and average values for T1 kept open

**4.2. Simulation Results for the Bottom Transistor 1 kept Open Arms (Open Fault T4)**

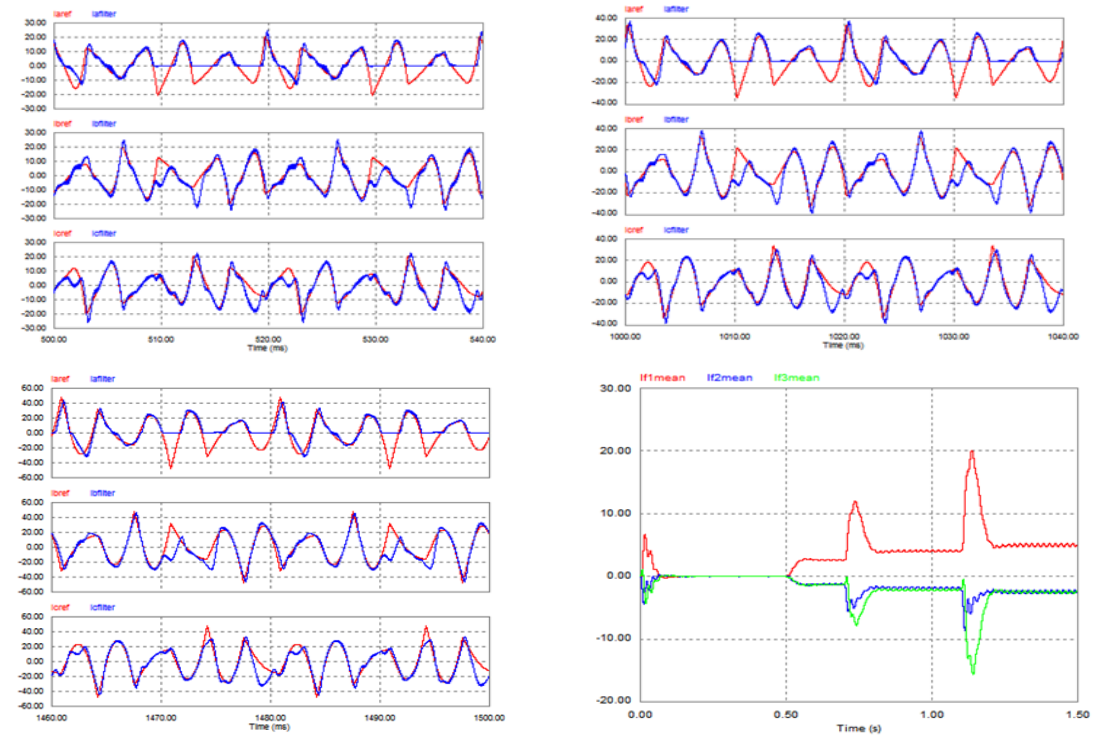

Figure 10. Harmonic currents identified by the method of real power and instantaneous imaginary and currents injected by the FAP based voltage inverter 2 levels and average values for T4 kept open

4.3. Simulation Results for the Top of Transistor 2 held Open Arms (Open Fault T2)

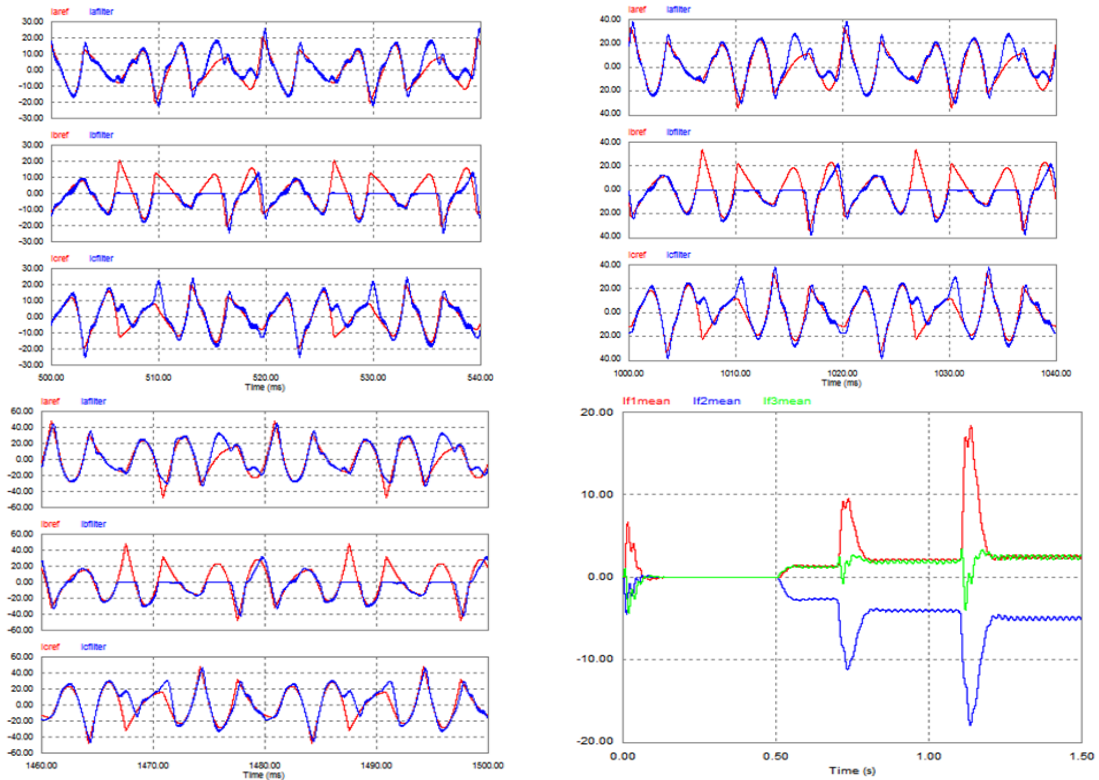

Figure 11. Harmonic currents identified by the method of real power and instantaneous imaginary and currents injected by the FAP based voltage inverter 2 levels and average values for T2 kept open

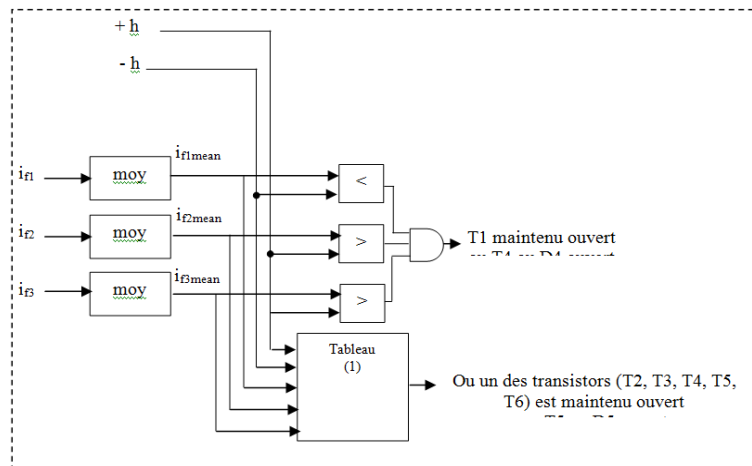

Figure 12. Fault Tree proposed for the detection and localization of the transistor open faults a non-autonomous FAP based voltage inverter 2 levels

Following the above analysis, we can develop a type of transistor failure detection algorithm held open based on the following Table 1 and Figure 12 h as the maximum threshold of the DC components of the phase currents of the FAP in healthy:



Table 1. Characteristics of open transistor fault (DC components of the phase currents) for a non-autonomous PAPF based on cascaded bridges 2-level voltage source inverter

kept open transistor	Polarity of the transistor type of fault indicators maintained (DC components or average values of FAP phase currents)		
T1	$i_{f1\text{mean}} < -h$	$i_{f2\text{mean}} > +h$	$i_{f3\text{mean}} > +h$
T2	$i_{f1\text{mean}} > +h$	$i_{f2\text{mean}} < -h$	$i_{f3\text{mean}} > +h$
T3	$i_{f1\text{mean}} > +h$	$i_{f2\text{mean}} > +h$	$i_{f3\text{mean}} < -h$
T4	$i_{f1\text{mean}} > +h$	$i_{f2\text{mean}} < -h$	$i_{f3\text{mean}} < -h$
T5	$i_{f1\text{mean}} < -h$	$i_{f2\text{mean}} > +h$	$i_{f3\text{mean}} < -h$
T6	$i_{f1\text{mean}} < -h$	$i_{f2\text{mean}} < -h$	$i_{f3\text{mean}} > +h$

## 5. Conclusion

The most important task in a diagnostic system is the choice of fault indicators that need to be reliable for different system requirements in order to avoid confusion between a default and another. In this article, an analysis is conducted to identify these indicators for diagnosing open transistor faults in a non-autonomous PAPF based on 2-level. This study has shown that for the PAPF based on two-level voltage source inverter, the average values of filter phase currents can be considered as reliable indicators of open transistor fault.

## References

- [1] D Kastha, BK Bose. Investigation of fault modes of voltage-fed inverter system for induction motor drive. *IEEE Transactions on Industry Applications*. 1994; 30(4): 1028-1038.
- [2] C Thybo. *Fault-tolerant control of induction motor drive applications*. Proceedings of the American Control Conference. 2001; 4: 2621- 2622.
- [3] RL De Araujo Ribeiro, CB Jacobina, ER da Silva, AMN Lima. Fault detection of open-switch damage in voltage-fed PWM motor drive systems. *IEEE Transactions on Power Electronics*. 2003; 18(2): 587-593.
- [4] M Beltrao de Rossiter Correa, C Brandao Jacobina, ER Cabral da Silva, AM Nogueira Lima. An induction motor drive system with improved fault tolerance. *IEEE Transactions on Industry Applications*. 2001; 37(3): 873-879.
- [5] CB Jacobina, MBR Correa, RF Pinheiro, AMN Lima, ERC da Silva. *Improved fault tolerance of active power filter system*. IEEE 32nd Annual Power Electronics Specialists Conference PESC. 2001; 3.
- [6] Jarupula Somlal, Venu Gopala Rao Mannam, Narsimha Rao Vutlapalli. Power Quality Improvement in Distribution System using ANN Based Shunt Active Power Filter. *International Journal of Power Electronics and Drive System (IJPEDS)*. 2015; 5(4): 568-575.