

Performance Characteristics of Six-Phase Induction Generator for Renewable Power Generation

Alok Kumar Mohanty*, K. B. Yadav

Department of Electrical & Electronics Engineering, National Institute of Technology, Jamshedpur, Jharkhand, India

*Corresponding author, e-mail: alokmoh@gmail.com

Abstract

This paper presents the performance characteristics of a multi-phase induction generator operating in six-phase mode. An experimental analysis has been done to determine operating characteristics of the six-phase machine to illustrate the advantageous features of the machine. The multi-phase machine is configured to operate as a standalone power source in conjunction with a DC prime mover. The multi-phase machine can operate with one three phase capacitor bank which does not lead to complete shutdown of the system during fault conditions across one of its two sets of its stator windings. In the analysis the multi-phase machine is connected to different capacitor configuration and the influence of these connections on the machine performance during no load and load have been implemented. Experimental results include voltage build-up of the machine with different excitation capacitors at both sets of stator windings with changing speed during no load condition, resistive load condition and resistive inductive load condition with simple shunt and short shunt configuration.

Keywords: Multi-phase, Standalone, Self-excited, Induction Generator

Copyright © 2017 Institute of Advanced Engineering and Science. All rights reserved.

1. Introduction

The decrease in fossil fuels over the last three decades and with a growing concern for pollution occurring in the environment has led to an increase in renewable power generation. As a consequence a greater emphasis is now being given to the harnessing of energy from non-conventional sources such as wind, hydro, solar etc. Suitable stand-alone systems using locally available energy sources have become a preferred option. Self-excited induction generators (SEIGs) are considered as a viable option due to its specific advantages compared to a conventional synchronous generator. The squirrel cage induction generator in self-excited mode is found to be the most suitable option as generator due to such advantages as low cost, simple construction, ruggedness, and brushless rotor, absence of DC source, maintenance-free nature, and self-protection against short circuits [1-3].

In the last two decades the investigation for power transmission for phases more than three [4], in general the multi-phase induction machines have gained much importance [5-7]. In comparison with three phase machines, multi-phase machines are considered as an alternative for variable speed applications. The multi-phase machine are considered advantageous as compared with its three phase counterpart as the rating of power is increased and high reliability requirements and additional number of phase added to the machine also brings additional freedom for improvements in the system, hence research in the area of multi-phase machines have been increasing. The first article on multi-phase induction generator [8] was published in the year 2005 which was added by some more work on six-phase induction generator [8-12]. The modeling and analysis of the six-phase induction generator was presented by Singh, et al., [8-10]. The performance of the six-phase induction machine was discussed by Singh, et al., in [10-12].

In this paper an experimental treatment is provided with the emphasis placed on operating regimes of a six-phase self-excited induction generator (SP-SEIG). In particular, it is shown that the SP-SEIG can operate with a single three-phase capacitor bank, so that the loss of excitation or fault at one winding does not lead to the system shutdown. The generator can also supply two separate three-phase loads, which represents an additional advantage. Last but not least, outputs of the two three-phase windings can be used to supply a single

three-phase load in which case failure of one three-phase winding does not lead to the system shutdown and the load can be still supplied from the remaining healthy winding. Experimental results include voltage build up of the machine with different excitation capacitors at both sets of stator windings with changing speed during no load condition, resistive load condition and resistive inductive load condition with simple shunt and short shunt configuration.

2. Experimental System Description

In order to investigate the performance of proof-of-concept system for establishing the advantageous feature of six-phase induction generator over three phase counterpart, experimentation was performed on a DC motor driven induction generator. For this purpose, a three-phase, 36-slots, 1kW, 415 V, 50 Hz, 1000 rpm squirrel cage induction machine was utilized as the basis. Experimentation was carried out in this set up to determine the performance parameters of six phase induction machine in which all the seventy two stator coil terminals were taken out to the terminal box mounted on the top of the machine casing, so that various winding schemes for different number of poles and phases can be realized. The six-pole, six-phase connection was obtained by employing phase belt splitting. The six stator phases are divided into two star-connected three-phase sets, with magnetic axes of the two three-phase sets displaced by an angle of 30 degrees electrical. Neutral points of two three-phase stator winding sets are kept isolated in order to prevent physical fault propagation from one three-phase set to other one.

2.1. Magnetization Characteristics

The magnetization characteristic of the multi-phase machine is very important from the performance analysis point of view. This characteristic is obtained by conducting the synchronous speed test on the test machine. When a standalone self excited induction generator is driven by a prime mover, the residual magnetism in the rotor of the machine induces an EMF in the stator windings at a frequency proportional to the rotor speed. This EMF is applied to the capacitors connected to the stator terminals and causes reactive current to flow in the stator windings. Hence a magnetizing flux in the machine is established. The ultimate magnitude of the voltage in the stator windings is limited by the saturation of the magnetic path within the machine. The induction machine is then capable of operating as a generator in isolated locations without a grid supply. When the induction machine is self-excited and connected to the load, the steady-state voltage is generated by the SEIG, the value of the self-excitation capacitance, speed, machine parameters and terminal loads.

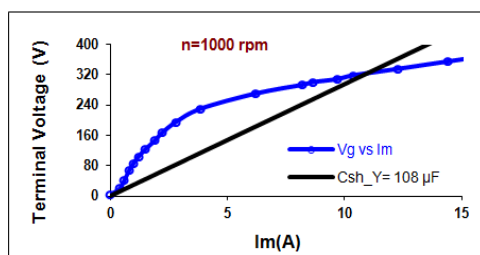

Figure 1. Magnetization characteristics of the six-phase induction generator for shunt capacitance of $108\mu\text{F}$

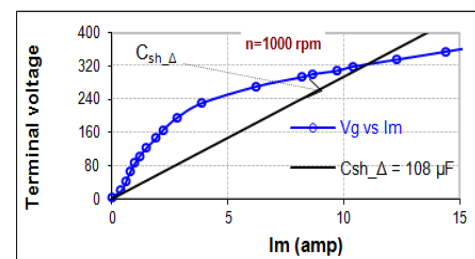

Figure 2. Magnetization characteristics of the six-phase induction generator for shunt capacitance of $108\mu\text{F}$

There is intersection between the magnetization curve and the capacitor reactance line as shown in the Figure 1 and Figure 2 respectively. Figure 1 show the magnetization characteristics when the machine excitation capacitances are connected in star whereas Figure 2 displays the characteristics when the machine excitation capacitances are connected in delta. Figure 3 shows the variation of magnetizing current with inductances.

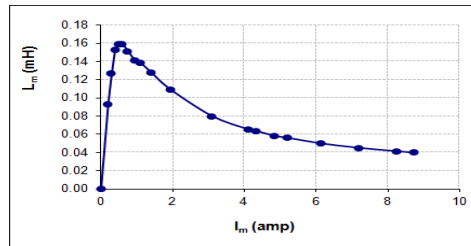

Figure 3. Variation of magnetizing current with magnetizing inductance

3. Performance Characteristics of the Six-phase Induction Generator

To determine the performance behavior of the six-phase machine is connected with different excitation capacitors at both set of stator 3-ph windings. The diagrammatic representation of stand-alone six-phase self-excited induction generator in simple shunt mode of operation has been shown in Figure 4. The test machine is first subjected to no load condition and then with loads with changing speed and excitation capacitances. Figure 5 shows the winding pattern of six-phase self-excited induction generator.

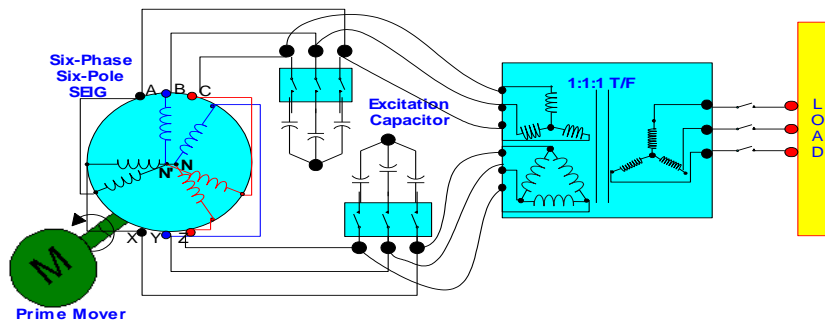

Figure 4. Diagrammatic representation of stand-alone six-phase self-excited induction generator in simple shunt mode of operation

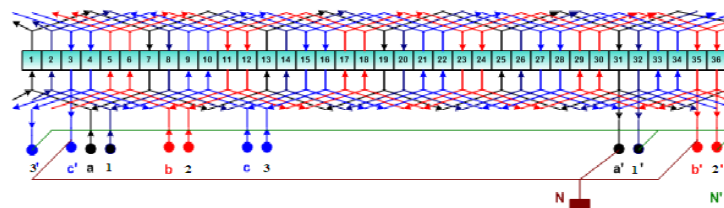

Figure 5. Winding pattern of a six-phase induction generator

3.1. No-load Condition

The test machine is connected to two different excitation capacitance values and the machine is made to run under no load condition. During first test capacitance of value $108\mu\text{F}$ is connected at both set of stator 3-phase windings and in second case the machine is connected to capacitance of $100\mu\text{F}$ at both set of stator 3-phase windings. The variation of the voltage generated across the two sets of stator windings with speed is shown in Figure 6. It is observed with greater value of shunt capacitance the voltage build up is faster as compared to lesser value of capacitance. The variation of frequency during excitation of the machine with magnetizing current and speed is shown in Figure 7 and 8. The variation of armature current with speed during excitation with two different capacitances of the test machine is displayed in Figure 9. The armature current starts increasing approximately at 800rpm and 760rpm for $100\mu\text{F}$ and $108\mu\text{F}$ respectively.

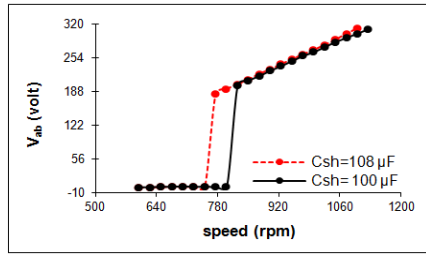

Figure 6. Voltage build-up at different excitation capacitances

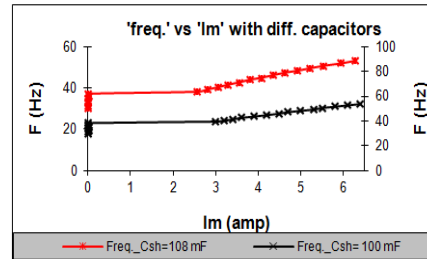

Figure 7. Variation of frequency with magnetizing current at different excitation capacitances

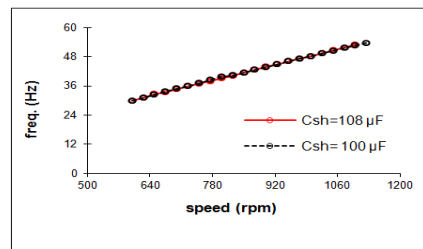

Figure 8. Variation of frequency with speed current at different excitation capacitances

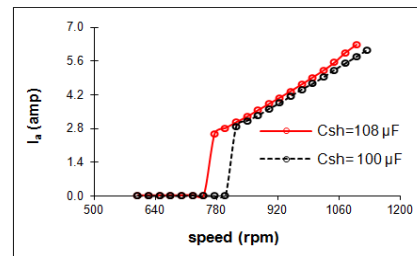

Figure 9. Variation of current with speed at different excitation capacitances

Under no load condition the machine is de-excited and the variations of the system parameter are observed. The variation of voltage and frequency with decreasing speed when connected to two different capacitances are shown in Figure 10 and Figure 11 respectively.

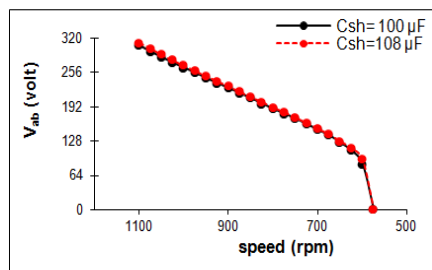

Figure 10. De-excitation of the machine at different capacitances

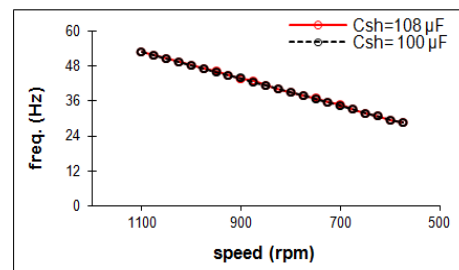

Figure 11. Variation of Frequency with speed during de-excitation of the machine

3.2. Loading Characteristics of Six-phase Self-excited Induction Generator

In this analysis the test machine is gradually loaded to the Y-connected lamp load till collapse by maintaining the prime mover speed at 1100, 1000 and 900rpm respectively and the variation of the parameters were evaluated. During the first analysis the test machine was being connected to a shunt capacitance of 108 μ F. The variation of frequency and voltage with power output (KW) for varying lamp loads at different speeds is shown in Figure 12 and 13. The variation of load current and voltage across abc windings with power output (KW) for varying lamp loads at different speeds is shown in Figure 14 and Figure 15.

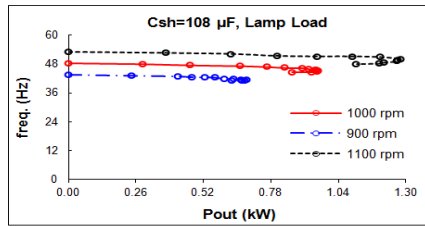

Figure 12. Variation of frequency with output power at different capacitances

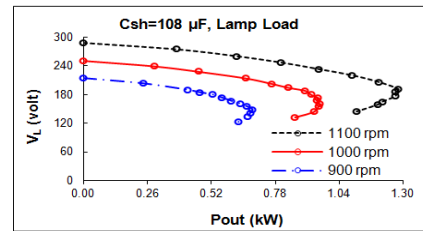

Figure 13. Variation of voltage with output power at different capacitances

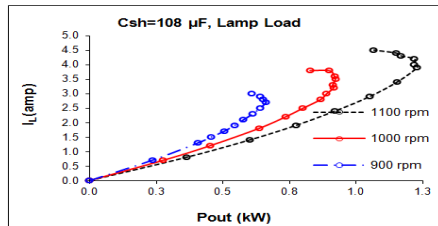

Figure 14. Variation of current with output power at different capacitances

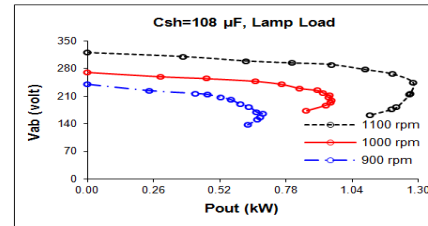

Figure 15. Variation of voltage with output power at different capacitances

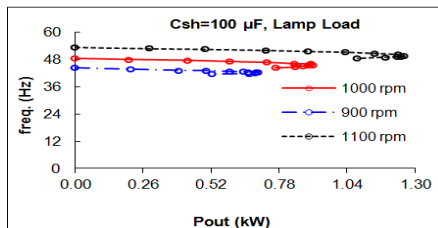

Figure 16. Variation of frequency with output power at different speeds at shunt capacitance of 100 μF

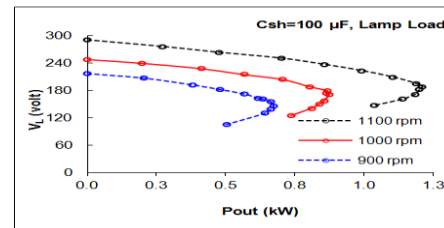

Figure 17. Variation of load voltage with output power at different speeds at shunt capacitance of 100 μF

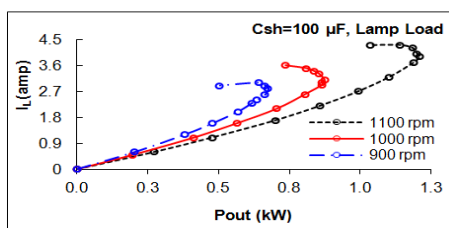

Figure 18. Variation of current with output power at different speeds at shunt capacitance of 100μF

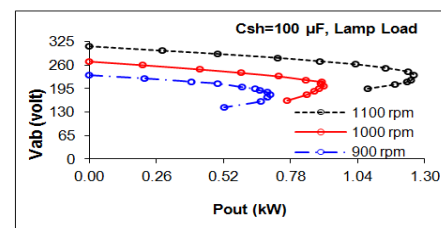

Figure 19. Variation of voltage with output power at different speeds at shunt capacitance of 100μF

The machine is gradually loaded to the Y-connected lamp load till collapse by maintaining the prime mover speed at 1100, 1000 and 900rpm respectively and the variation of the parameters were evaluated. During the analysis the test machine was being connected to a shunt capacitance of 100 μ F. The variation of frequency and voltage with power output (KW) for varying lamp loads at different speeds is shown in Figure 16 and 17. The variation of load current and voltage across abc windings with power output (KW) for varying lamp loads at different speeds is shown in Figure 18 and Figure 19 respectively.

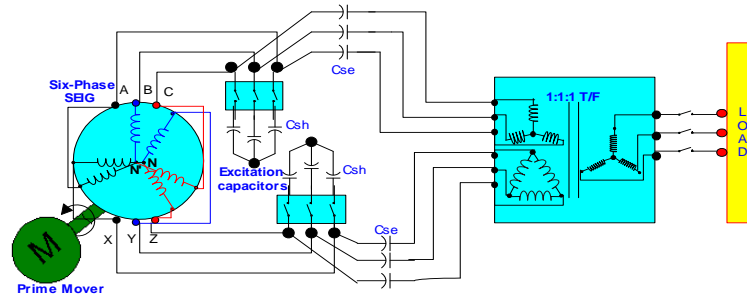

Figure 20. Diagrammatic representation of stand-alone six-phase self-excited induction generator in short shunt mode of operation

3.3. Loading Characteristics of Multi-phase Induction Generator when Connected to Varying Lamp Load with Fixed Short Shunt Capacitor Excitation

In this analysis the test machine is connected to capacitor in short shunt configuration connected across each of the three phase stator windings and series compensated by 108 μ F and the machine is made to operate at 1100, 1000 and 900rpm respectively. The variation of frequency, V_L , I_L with power output when the test machine is connected to varying lamp load with a speed of 1100, 1000 and 900rpm when the shunt capacitances of 108 μ F and 100 μ F are connected is shown in Figure 21, Figure 22 & Figure 23 respectively. The variation of frequency for 1.1 of rated speed varies between 53 to 43.5Hz, for speed of 1.0 of rated speed varies between 48.4 to 44.2Hz and for speed 9 of rated speed the variation lies between 43.9 to 40.2Hz respectively. At 1.1 of rated speed the voltage across the load varies from 287.7 volts to 128 volts, for speed at 1.0 of rated speed the load voltage varies from 252.9 volts to 98.9volts and for speed at 9 of rated speed the load voltage varies from 218.9 to 86.5volts. The load current at speed of 1.1 of rated speed varies from 0.8 to 4.9A, at speed of 1.0 of rated speed varies from 0.7 to 4.8A and at speed of 9 of rated speed it varies from 0.7 to 4.5A. The power output varies from 0.36 to 1.03kw at 1.1 of rated speed, 0.27 to 0.78Kw at 1.0 of rated speed and 0.24 to 0.64Kw at 9 of rated speed respectively.

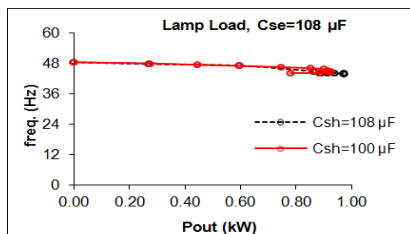

Figure 21. Variation of frequency with output power at different speeds at shunt capacitance of 100 μ F & 108 μ F and series capacitance of 108 μ F

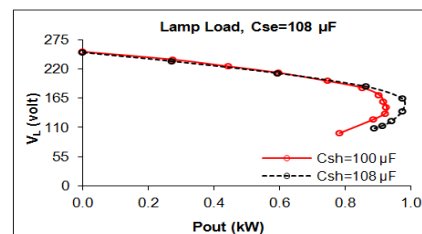

Figure 22. Variation of voltage with output power at different speeds at shunt capacitance of 100 μ F & 108 μ F and series capacitance of 108 μ F

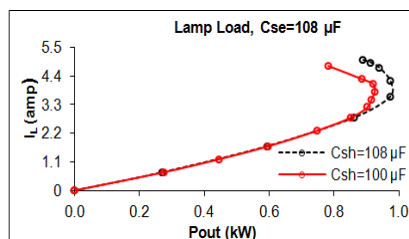

Figure 23. Variation of current with output power at different speeds at shunt capacitance of 100 μ F & 108 μ F and series capacitance of 108 μ F

Now in order to differentiate the performance parameters of the test machine during conditions of with and without series compensation an analysis have been made with se capacitance of $C_{se} = 108\mu F$. The shunt capacitance connected across the test machine is $100\mu F$. The variation of the frequency, voltage and current during condition of with and without series compensation have been displayed in Figure 24, Fiure 25 and Figure 26 respectively.

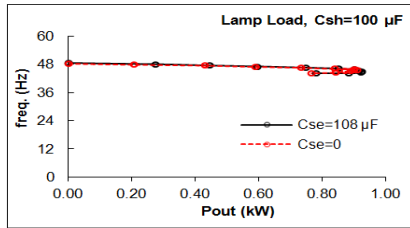

Figure 24. Variation of frequency with output power at shunt capacitance of $100\mu F$ (with and without series capacitance of $108 \mu F$)

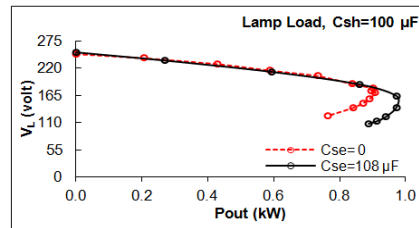

Figure 25. Variation of voltage with output power at shunt capacitance of $100\mu F$ (with and without series capacitance of $108 \mu F$)

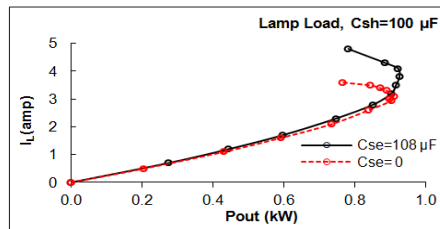

Figure 26. Variation of current with output power at shunt capacitance of $100\mu F$ (with and without series capacitance of $108 \mu F$)

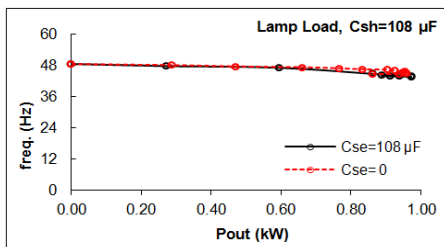

Figure 27. Variation of frequency with output power at shunt capacitance of $108\mu F$ (with and without series capacitance of $108 \mu F$)

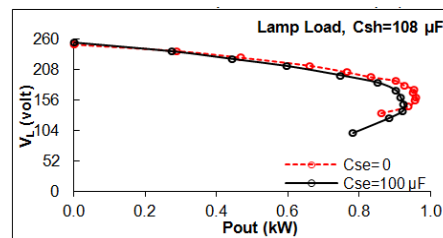

Figure 28. Variation of voltage with output power at shunt capacitance of $108\mu F$ (with and without series capacitance of $108 \mu F$)

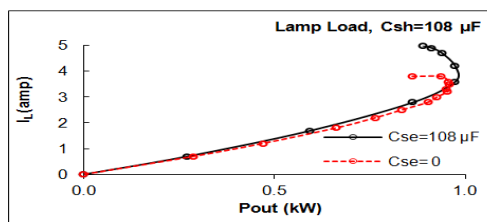

Figure 29. Variation of current with output power at shunt capacitance of $108\mu F$ (with and without series capacitance of $108 \mu F$)

Now the shunt capacitance connected across the test machine is changed to $108\mu\text{F}$ and the series compensation capacitance connected is also $108\mu\text{F}$ and the machines is connected to varying lamp loads and comparison of with and without series compensation have been analyzed. The variation of the frequency, voltage and current during condition of with and without series compensation have been displayed in Figure 27, Figure 28, and Figure 29 respectively.

3.4. Loading Characteristics when the Test Machine is Subjected to Rheostat Loading with Simple Shunt $C_{sh}=90\mu\text{f}$

In this analysis three phase stator winding of the six-phase machine is being connected to rheostat load and the test machine is made to run at 1100, 1000 and 900rpm respectively. The variation of frequency, current, voltage with power output at different speed is shown in Figure 30, 31, and 32 respectively. The variation of power factor at 1100rpm varies from 0.80 to 0.99, for speed at 1000 rpm varies from 0.60 to 0.98 and for speed at 900rpm the variation lies between 0.44 to 0.97 respectively. At 1100rpm speed the voltage across the load varies from 310.7 volts to 204.4 volts, for speed at 1000rpm the load voltage varies from 269 volts to 171.6volts and for speed at 900rpm the load voltage varies from 229.5 to 134 volts. The load current at speed of 1100rpm varies from 0.5 to 3.3A, at speed of 1000rpm varies from 0.4 to 2.9A and at speed of 900rpm varies from 0.4 to 2.2A. At 1100rpm speed the frequency varies from 53.2Hz to 50.2Hz, for speed at 1000rpm it varies from 48.6 to 45.8Hz and for speed at 900rpm it varies from 44 to 41.3Hz respectively. The power output varies from 0.22 to 1.15kw at 1100 rpm speed, 0.1 to 0.81Kw at 1000rpm speed and 0.07to 0.49Kw at 900rpm respectively.

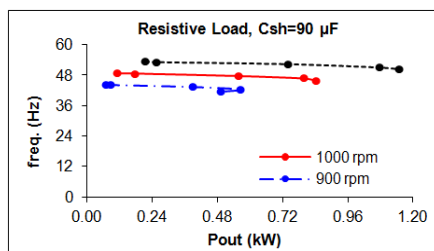

Figure 30. Variation of frequency with output power at different speeds with shunt capacitance of $90\mu\text{F}$ during resistively loaded

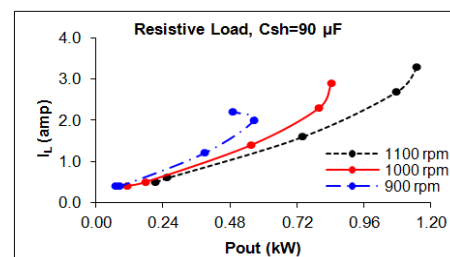

Figure 31. Variation of current with output power at different speeds with shunt capacitance of $90\mu\text{F}$ during resistively loaded

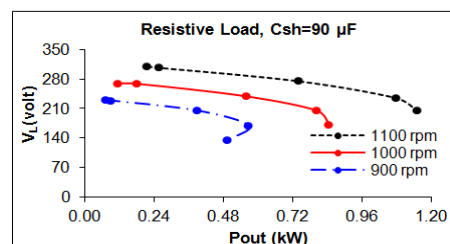

Figure 32. Variation of voltage with output power at different speeds with shunt capacitance of $90\mu\text{F}$ during resistively loaded

3.5. Loading Characteristics when the Test Machine is Subjected to Static RL Load with Short Shunt $C_{sh}=90\mu\text{f}$ and $C_{se}=108\mu\text{f}$

Here both the three phase stator winding is being connected to RL load and the test machine is made to run at 1100, 1000 and 900rpm respectively. The variation of frequency, current, voltage with power output at different speed is shown in Figure 33, 34, 35 respectively. The variation of power factor at 1100rpm varies from 0.66 to 0.56, for speed at

1000 rpm varies it from 0.40 to 0.52 and for speed at 900rpm the variation lies between 0.44 to 0.71 respectively. At 1100rpm speed the voltage across the load varies from 332 volts to 294.4 volts, for speed at 1000rpm the load voltage varies from 282 volts to 248volts and for speed at 900rpm the load voltage varies from 232.4to 194.8 volts. The load current at speed of 1100rpm varies from 0.4 to 2.5A, at speed of 1000rpm varies from 0.4 to 2.1A and at speed of 900rpm varies from 0.4 to 1.8A. At 1100rpm speed the frequency varies from 53.8Hz to 52.1Hz, for speed at 1000rpm it varies from 48.5 to 47.3Hz and for speed at 900rpm it varies from 43.9 to 42.6Hz respectively. The power output varies from 0.21 to 1.15kw at 1100 rpm speed, 0.18 to 0.81Kw at 1000rpm speed and 0.15 to 0.5Kw at 900rpm respectively.

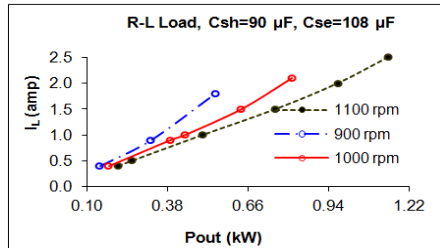

Figure 33. Variation of current with output power at different speeds with shunt capacitance of $90\mu\text{F}$ and series capacitance of $108\mu\text{F}$ during RL load

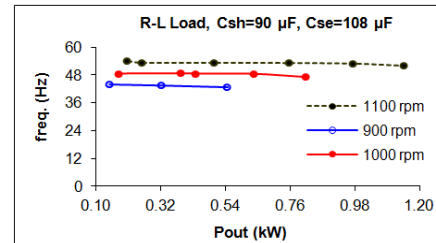

Figure 34. Variation of frequency with output power at different speeds with shunt capacitance of $90\mu\text{F}$ and series capacitance of $108\mu\text{F}$ during RL load

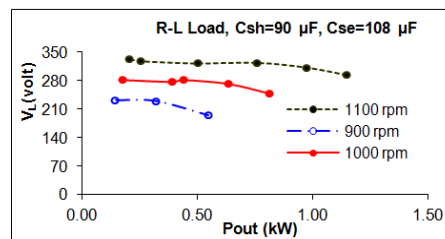

Figure 35. Variation of voltage with output power at different speeds with shunt capacitance of $90\mu\text{F}$ and series capacitance of $108\mu\text{F}$ during RL load

4. Conclusion

In this paper a detailed investigation of the six-phase induction generator during no load and resistive and resistive-inductive load is presented. A comparative performance analysis has been carried out with simple shunt and short shunt configuration. Based on the experimental analysis it is found that efficiency is better for simple shunt configuration where as voltage regulation is better for short shunt connection. The series compensation capacitor should be chosen carefully such that desired voltage regulation is achieved and maximum output power is obtained. From the experimental results it is clear that a six-phase induction generator can be excited by single three phase capacitor bank. This implies that if there is no excitation at one stator winding set it does not lead to complete shutdown of the system.

References

- [1] RC Bansal. Three-Phase Self-Excited Induction Generators: An Overview. *IEEE Transactions on Energy Conversion*. 2005; 20(2): 292-299.
- [2] Singh GK. Self-excited induction generator research—a survey. *Electr Power Syst Res*. 2004; 69: 107-114.
- [3] Alghuwainem S. Steady-state analysis of self-excited induction generator including transformer saturation. *IEEE Trans Energy Convers*. 1999; 14: 667-672.

- [4] Tiwari SN, Singh GK, Saroor ASB. Multiphase power transmission research—a survey. *Electr Power Syst Res.* 1992; 24: 207-215.
- [5] Jones M, Levi E. *A literature survey of state-of-the-art in multi-phase ac drives.* In Proc. 36th Univ. Power Eng. Conf. UPEC. Stafford, U.K. 2002: 505-510.
- [6] Singh GK. Multi-phase induction machine drive research – a survey. *Electr Power Syst Res.* 2002; 61: 139-147.
- [7] Klingshirn EA. High phase order induction motors – PartI: experimental results. *IEEE Trans Power Appl Syst.* 1983; 102: 54-59.
- [8] Singh GK, Yadav KB, Saini RP. *Modeling and analysis of multi-phase (sixphase) self-excited induction generator.* In Proc. IEEE conf. the eighth international conference on electrical machines and systems, ICEMS'05. 2005; 3: 1922-1927.
- [9] Singh GK, Yadav KB, Saini RP. Analysis of a saturated multi-phase (six-phase) self-excited induction generator. *Int J Emerg Electr Power Syst.* 2006; 7: 1-23.
- [10] Singh GK. Modeling and experimental analysis of a self-excited six-phase induction generator for stand-alone renewable energy generation. *Int J Renew Energy.* 2008; 33: 1605-1621.
- [11] Singh GK, Yadav KB, Saini RP. *Capacitive self-excitation in six-phase induction generator for small hydro power – an experimental investigation.* In Proc. IEEE conf. power electronics, drives and energy systems for industrial growth-2006, PEDES-2006. New Delhi. 2006.
- [12] Singh GK, Yadav KB, Saini Rp. *A Self-excited six-phase induction generator for stand-alone renewable energy generation.* In Proc. IEEE international Agean conference on electric machines, power electronics and electromotions, ACEMP'07. Bordrum, Turkey. 2007: 690-695.

Appendix

The parameters for the test machine are as follows

$R_{s1} = R_{s2} = 0.12$; $R_{rr} = 0.26$; $X_{s1} = X_{s2} = 0.12$; $X_r = 0.4$