

OFDM Performance Evaluation under Different Fading Channels using Matlab Simulink

Pratima Manhas*¹, M.K Soni²

FET, ECE Department, Manav Rachna International University, Faridabad, India

*Corresponding author, email: pratimamehak@gmail.com¹, ed.fet@mriu.edu.in²

Abstract

Orthogonal Frequency Division Multiplexing (OFDM) is a form of Multicarrier Modulation (MCM) technique in which larger bandwidth is divided into parallel narrow bands each of which is modulated by different subcarriers. All the subcarriers are orthogonal to each other and hence it reduces the interference among various subcarriers. OFDM technique is an efficient modulation technique used in certain wired and wireless application. During transmission, the transmitted signal can travel from transmitter to receiver over multiple reflective paths in case of wireless communication system which results to multipath fading and produces variation in amplitude, phase and angle of the received signal. The signal which is transmitted from BTS (base transceiver station) may undergo multiple reflections from the buildings nearby, before reaching the mobile station. This paper discusses the performance of OFDM system using various fading channels and channel coding. The parameter which is known as Bit error rate (BER) is calculated for different fading channels (AWGN, Rayleigh and Rician) for different digital modulation (BPSK, QPSK and QAM). The tool which is used to evaluate the BER parameter is Matlab Simulink.

Keywords: Multi carrier Modulation, Fading, Rayleigh, Rician, Subcarriers, Bit Error Rate, Simulink

Copyright © 2017 Institute of Advanced Engineering and Science. All rights reserved.

1. Introduction

OFDM is an efficient digital modulation technique which is commonly used in both wired and wireless communication system. For wired application it is used in DSL, ADSL and for wireless application it is used in wireless LAN. It is a bandwidth efficient technique where larger bandwidth is divided into parallel narrow bands and each of which is modulated by different subcarriers. OFDM has high Peak to Average Power Ratio (PAPR) and synchronization errors. The performance of OFDM is calculated by using different fading channel and different digital modulations [1-4].

1.1 Fading Channel

Fading results in a signal loss either in amplitude or phase due to sudden changes in Channel response. The fading is a random process which produces change in time, geographical position or radio frequency. Fading may be either due to multipath propagation (multipath induced fading) or due to shadowing from the obstacles (shadow fading). Some examples of the channels used to model multipath fading are:

a. AWGN channel

An AWGN channel is formed by adding white Gaussian noise to the signal that passes through it.

b. Rayleigh channel

Rayleigh fading occurs when multipath propagation exists. The Rayleigh fading model can be used to examine radio signal propagation on a statistical basis.

c. Rician channel

Fading produces the signal to spread and become diffuse. The Rician Fading Channel block is used to implement a baseband simulation of a Rician fading propagation channel.

2. Proposed Simulink Model

The simulink model for OFDM system using various fading channels (AWGN, Rayleigh and Rician) and digital modulations (BPSK, QPSK and QAM) has the following steps and it is shown in Figure 1.

1. The Bernoulli binary generator is used to generate the input signal. After getting the input signal, various channel coding is applied. Then the channel coded input signal is mapped by using digital modulations (BPSK/QPSK and QAM).
2. Then the Inverse Fast Fourier transform (IFFT) is applied on the mapped output.
3. The output of Inverse Fast Fourier transform is passed through different fading channels such as AWGN, Rayleigh and Rician channel and after this demodulation is done to evaluate the BER parameter using Error rate calculation [7].

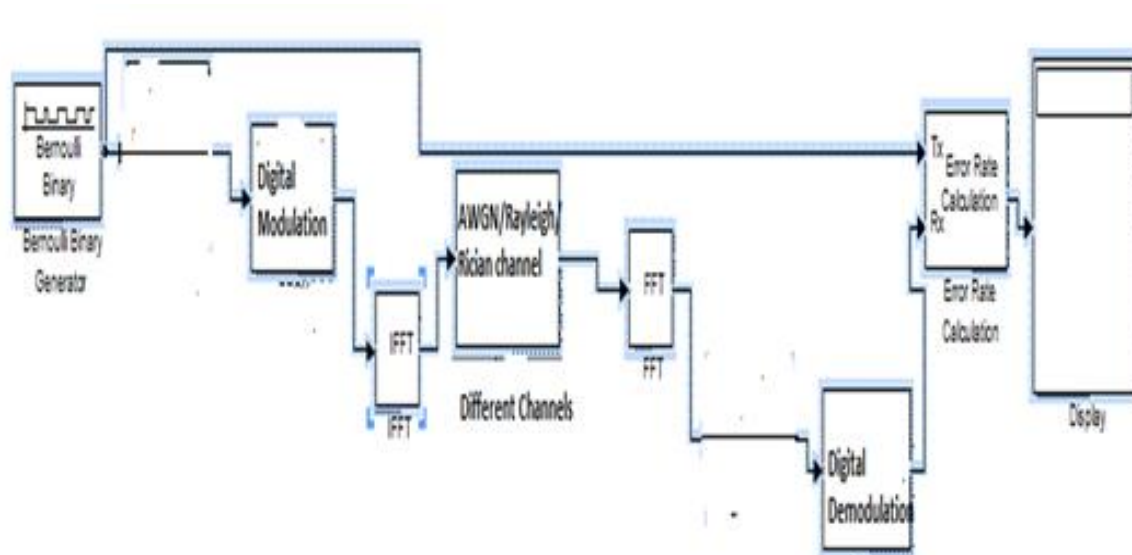

Figure. 1 Proposed Simulink model using different modulation and fading channels

2.1 Proposed OFDM model using AWGN Channel with different digital modulation

The proposed simulink model using AWGN channel including different channel coding is shown in Figure 2. In the given model the data is first encoded by using digital modulation and then the IFFT operation is performed on the modulated output. AWGN channel is used to pass the frequency domain signal and then it is converted into time domain and demodulated at the receiver side. The BER is calculated at the receiver side.

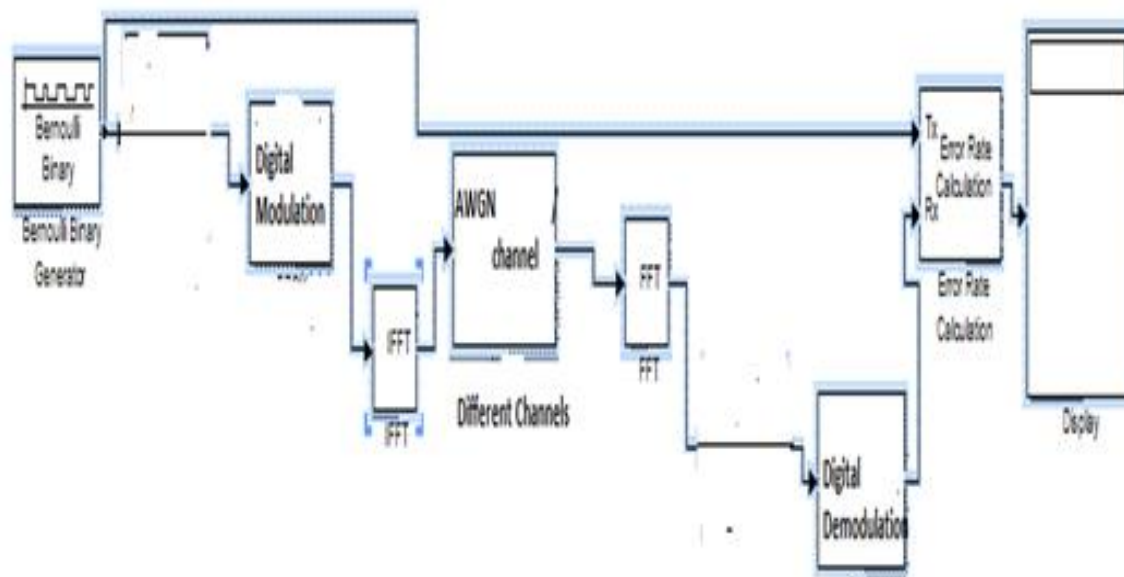

Figure 2. Proposed Simulink model using different modulation and AWGN channel

2.2 Proposed OFDM model using Rayleigh channel with different digital modulation

The Proposed simulink model using Rayleigh fading channel using Linear/Cyclic coding is shown in Figure 3. In the given model the data is first encoded by using digital modulation and then the IFFT operation is performed on the modulated output. Rayleigh channel is used to pass the frequency domain signal and then it is converted into time domain and demodulated at the receiver side. The BER is calculated at the receiver side.

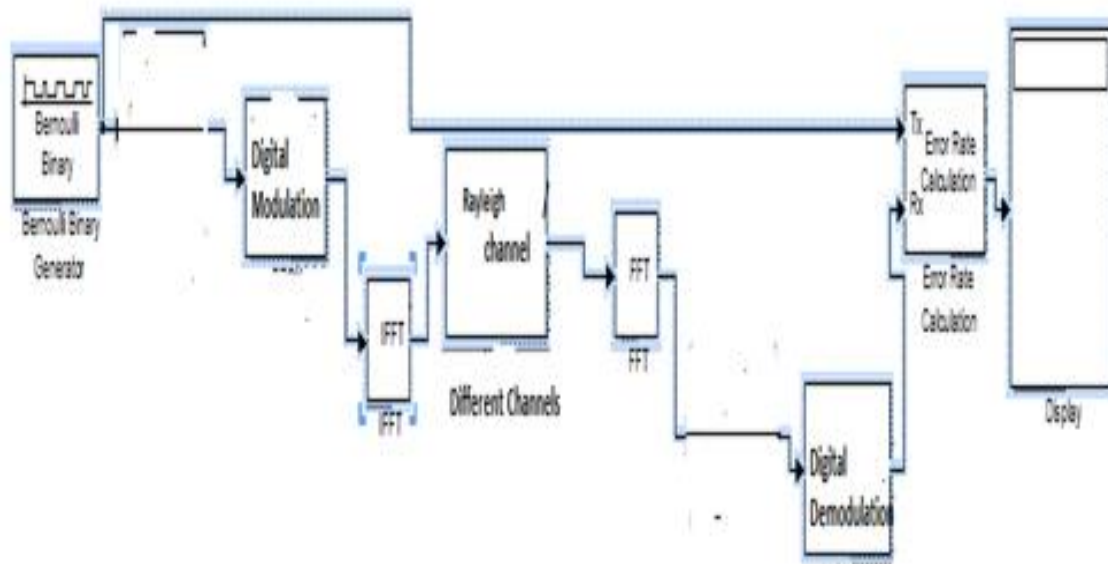

Figure 3. Proposed Simulink model using different modulation and Rayleigh channel

2.3 Proposed OFDM model using Rician channel with different digital modulation

The Proposed model using the Rician fading channel using different digital modulation is shown in Figure 4. In the given model the data is first encoded by using digital modulation and then the IFFT operation is performed on the modulated output. Rician channel is used to pass the frequency domain signal and then it is converted into time domain and demodulated at the receiver side. The BER is calculated at the receiver side.

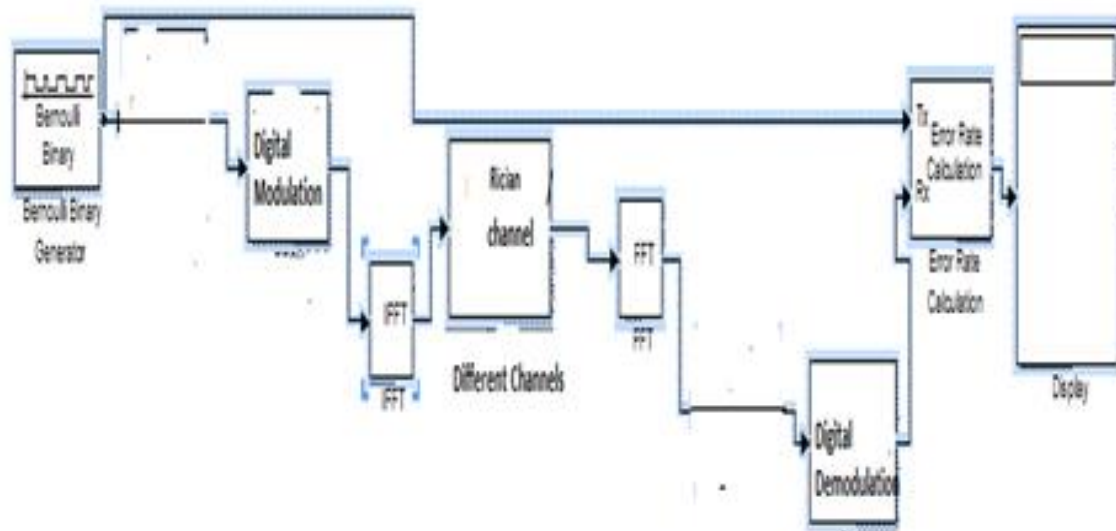

Figure 4. Proposed Simulink model using different modulation and Rician channel

3. Simulation Results

The simulation parameters which are used for the proposed work are given below:

- a. Digital Modulation Technique = BPSK, QPSK and QAM
- b. Fading Channel= AWGN, Rayleigh and Rician

The BER results of OFDM system using various fading channel and digital modulation are shown in Figure 7. In the given Figure 5, the BER results has been calculated by using different digital modulation along with AWGN channel. The Figure 5 results in BER calculation for AWGN channel along with BPSK modulation.

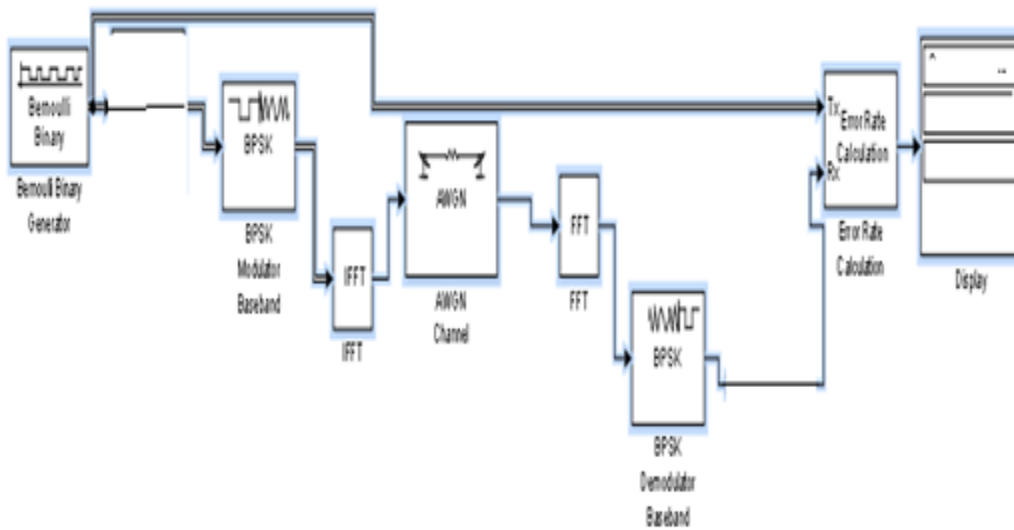

Figure 5. BER results of OFDM system using different digital modulation and AWGN channel

The BER calculation of FFT based OFDM system for different digital modulation and fading channels are shown in below in Table 1 and bar chart is represented in Figure 6. In Figure 6, the AWGN channel results in minimum value of BER as compared to other fading channels.

Table 1. BER results of FFT based OFDM system with different fading channels and without channel coding

OFDM system with different modulation	AWGN channel	Rayleigh Channel	Rician Channel
BPSK	0.272	0.454	0
QPSK	0.3636	0.545	0.545
QAM	0.636	0.6363	0.909

The Table 1 deals with the BER results of FFT based OFDM system without channel coding for different fading channel. For different fading channels, AWGN channel results in minimum BER as compared to Rayleigh and Rician channel. The BER value using Rayleigh channel is more than Rician and AWGN. The OFDM system model using BPSK modulation and AWGN channel results in minimum BER. So, in order to model FFT based OFDM system, AWGN channel results in minimum value of BER.

BER results of FFT based OFDM system with different fading channels & without channel coding

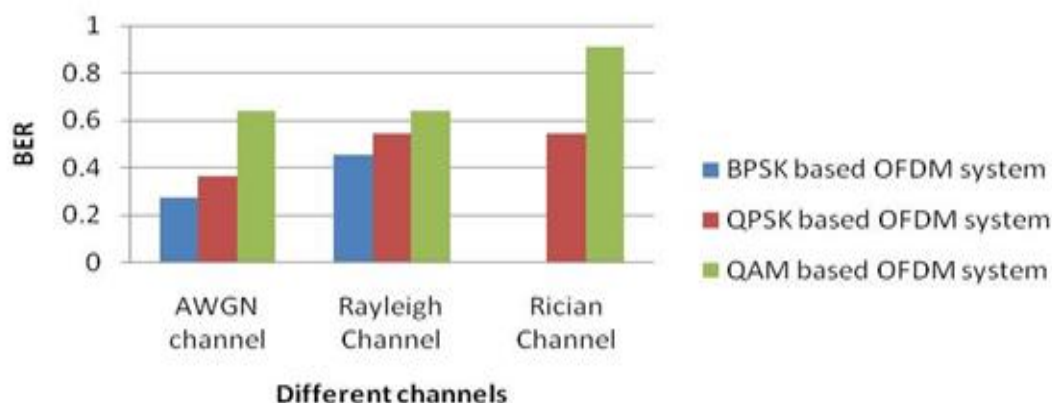

Figure 10. BER graph for various fading channel and without channel coding

4. Conclusion

The performance of FFT based OFDM system using various channels and channel coding is simulated using simulink model. The simulation results show that the BER is better in AWGN channel and worst in Rayleigh channel. Rician fading channel has better BER value than Rayleigh but less than AWGN channel. The BER value can be further reduced by using various channel coding.

References

- [1] Heiskala J, Terry J. OFDM wireless LANs: A theoretical and practical guide. Sams. 2001.
- [2] Nee RV, Prasad R. OFDM for wireless multimedia communications. Artech House, Inc. 2000.
- [3] Jiang T, Wu Y. An overview: peak-to-average power ratio reduction techniques for OFDM signals. *IEEE transactions on Broadcasting*. 2008; 54(2): 257.
- [4] Kaiser S. OFDM code-division multiplexing in fading channels. *Communications, IEEE Transactions on*. 2002; 50(8): 1266-1273.
- [5] Sanjiv Kumar, PK Gupta Singh, Chauhan DS. Performance analysis of Rayleigh and Rician fading channel models using Matlab simulation. *I.J intelligent systems and applications*. 2013; 9: 94-102.
- [6] Fazel K. *Performance of CDMA/OFDM for mobile communication system*. In Universal Personal Communications, 1993. Personal Communications: Gateway to the 21st Century. Conference Record, 2nd International Conference on. 1993; 2: 975-979.
- [7] Manhas P, Soni MK. Comparison of OFDM System in terms of BER using Different Transform and Channel Coding. *I.J engineering and manufacturing*. 2016; 1: 28-34.
- [8] Burr A, Kandus G. 2.3. Modulation and Coding. *Wireless Flexible Personalised Communications*, 2001: 51.
- [7] Ergen M. *Principles of OFDM*. In Mobile Broadband. Springer, US. 2009: 109-175.
- [9] Agarwal A, Patra SK. *March. Performance prediction of OFDM based DAB system using block coding techniques*. In Emerging Trends in Electrical and Computer Technology (ICETECT), 2011 International Conference on. 2011: 792-796).
- [10] Agarwal A. Digital Audio Broadcast: Modulation, Transmission & Performance Analysis. Doctoral dissertation. National Institute of Technology Rourkela; 2010.
- [11] Malhotra J. Investigation of Channel Coding Techniques for High Data Rate Mobile Wireless Systems. *International Journal of Computer Applications*. 2015; 115(3).
- [12] Rugini L, Banelli P. BER of OFDM systems impaired by carrier frequency offset in

- multipath fading channels. *Wireless Communications, IEEE Transactions on*. 2005; 4(5): 2279-2288.
- [13] Manhas P, Soni MK. OFDM PAPR Reduction Using Recurring SLM with Cyclic and Linear Block Codes Schemes. *TELKOMNIKA Indonesian Journal of Electrical Engineering*. 2015; 16(1): 1-6.