

# STATCOM with Battery and Super Capacitor Hybrid Energy Storage System for Enhancement of Voltage Stability

Tanneeru Renuka<sup>1</sup>, Gattu Kesavarao<sup>\*2</sup>

<sup>1</sup>E.E.E Department, K.L.University, Vijayawada, India, +91-8121188187

<sup>2</sup>E.E.E Department, K.L.University, Vijayawada, India

Corresponding author, e-mail: tanneerurenuka@gmail.com<sup>1</sup>, raogattu@kluniversity.in<sup>\*2</sup>

## Abstract

To maintain voltage stability of a power system STATCOM is better solution which can provide the required amount of reactive power under various disturbances. In previous work, STATCOM with various energy storage elements was discussed for voltage and power system stability. Apart from these previous works, this work proposes a new structure of hybrid energy storage system (HESS) for voltage stability by using battery and super capacitor. A new model of STATCOM with hybrid energy storage system is designed by using two bidirectional DC-DC converters and results are analyzed for conventional STATCOM and STATCOM with hybrid energy storage system. Results are also analyzed for STATCOM system with out any energy storage system, STATCOM with battery, STATCOM with super capacitor and STATCOM with HESS under sudden load changes by using MATLAB/Simulink.

**Keywords:** STATCOM, reactive power, hybrid energy storage system, DC-DC converter, voltage stability

Copyright © 2017 Institute of Advanced Engineering and Science. All rights reserved.

## 1. Introduction

With quick improvement of size of the power system and its complexity voltage stability is a major problem. It is very difficult to maintain power system stability under different disturbances which are unavoidably occurs in the system. The static compensator (STATCOM) was already proved for improving power system stability. These STATCOMs facilitates bulk power transfers in flexible networks without building more transmission lines and to minimize more number of power plants in the utility system. For transmission providers STATCOM was given an optimum solution to a variety of power system problems such as dynamic over voltages and under voltages, sub synchronous oscillations, transient and dynamic instability, uneven power flow through the system.

To compensate the voltage drop which is occurring across the ac transmission lines, lines must be compensated using shunt connected capacitors. Voltage compensation across ac transmission lines is one of the most notable advantages of STATCOM which replaces all the previous methods. The STATCOM is delivering the adequate amount of reactive power for dynamic voltage compensation. For this dynamic compensation STATCOM is controlling its three phase amplitude and phase angle on ac side. STATCOM acts as either inductor or capacitor while absorbing or injecting reactive power. STATCOM acts as an inductor while current flowing from ac side to capacitor and acts as capacitor while current flowing from capacitor to ac side. A capacitor with high capacity is used in STATCOM to deliver the adequate amount of dc power to the voltage source converter. In order to improve power system operations, small signal transient stability and voltage stability of the system in reference [1]. Z. Yang and C.Shen was introduced the concept of STATCOM with battery which was demonstrated the change of dynamic and transient dependability and transmission capacity of the power system.

In previous work, various energy storage methods have been proposed for STACOM. In reference [2] authors were designed energy storage type STATCOM which controls both active and reactive power absorption/injection to the power system. In [3] a new structure of STATCOM with SC (super capacitors) for improved power system dependability was designed to improve the voltage and system stability. References [4] to [10] shows different works of

STATCOM with different energy storage systems which are used in different areas of power system like wind turbine, arc furnace, smart grid and also for power oscillation damping. The batteries which are used as energy storage elements have some disadvantages. The main disadvantage is they unable to handle rapid power fluctuations.

To improve power system operations many authors have been used STATCOM and energy storage systems independently. There are many energy storage methods like batteries, fly wheels, compressed air energy, production of hydrogen, superconducting magnetic energy storage, super capacitors and hydro pump stations are mentioned in reference [11] by P.F. Ribeiro, M.L. Crow, B.K. Johnson, Y. Liu, and A. Arsoy. In reference [12] authors were studied about super capacitor with integration of DSTATCOM to improve power quality and enhance system reliability. Reference [13] explained and proved enhancement of performance of wind generator system taking after serious low voltage condition. Results are verified under low voltage situations for both single and multi machine models and additionally proved suppression of electro mechanical transients by using STATCOM and super capacitor combination. In reference [14] authors were taken the combination of SMES with STATCOM for efficient damping of SSR and improvement of power system stability by compensating real and reactive power. In reference [15] authors were designed effective controller for damping the electro mechanical oscillations of SMIB system by using STATCOM and BESS. From reference [16] to [19] authors different researches work on STATCOM with Energy storage system for different applications of power systems. Even in HVDC systems also energy storage systems plays major role [20].

Prediction of Voltage instability in Electric power systems is very difficult task and different methods are suggested by Researchers [21]. In order to maintain voltage stability power systems are heavily compensated with Reactive power and Real power. The main purpose of this research work is to compensate sufficient amount of reactive and real power to maintain system stability under various hazard conditions. For this compensation many scientist has shown different combinations of storage devices with STATCOM. Apart from these works, the main motive of this work is to introduce a new method of HESS for STATCOM with battery and super capacitor, which can provide sufficient amount of reactive power injection to improve voltage stability under sudden disturbance.

Based on this fundamental motivation, a HESS for STATCOM with battery and super capacitor is presented in this paper. With this method, STATCOM can be directly injecting the required amount of reactive power dynamically under sudden disturbances in a power system. This hybrid system completely depends on a VSC and it will be utilized as a regulating device.

## 2. STATCOM with HESS Model

The proposed diagram of a STACOM with HESS is shown in Figure 1. The STATCOM with HESS includes a VSC and a dc link with two bidirectional dc-dc converters and also two different types of energy storage systems. Due to its individual control of battery power and super capacitor power this model has more advantage. Their control strategy completely depends on state of supply requirements and state of charge of individual devices. In a super capacitor, energy storage is by means of static charge where as in battery energy storage is an electrochemical process. The power density of SC is much more than that of battery. The combination of these two devices is more advantageous in order to acquire better energy and power performances.

In the system shown in Figure 1,  $R_s$  is the series resistance with voltage source converter. It represents the total losses of the converter conduction and the transformer winding resistance losses.  $L_s$  is the transformer leakage inductance.  $R_c$  is the resistance which is in shunt with the capacitor. It represents the total losses of converter and losses in capacitor.  $V_{as}$ ,  $V_{bs}$  and  $V_{cs}$  represents STATCOM three phase output voltages;  $V_{al}$ ,  $V_{bl}$ , and  $V_{cl}$  represents bus voltages; and  $i_{as}$ ,  $i_{bs}$  and  $i_{cs}$  represents output currents of the STATCOM.

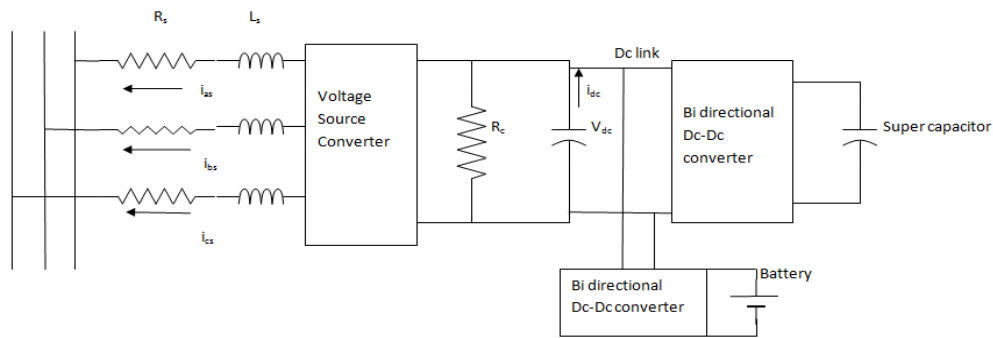

Figure 1. STATCOM with Hybrid Energy Storage System (S-HESS)

From references [22], [23] STATCOM three phase mathematical expressions are written in the following form

$$L_s \frac{d}{dt} i_{as} = -R_s i_{as} + V_{as} - V_{al} \quad (1)$$

$$L_s \frac{d}{dt} i_{bs} = -R_s i_{bs} + V_{bs} - V_{bl} \quad (2)$$

$$L_s \frac{d}{dt} i_{cs} = -R_s i_{cs} + V_{cs} - V_{cl} \quad (3)$$

$$\frac{d}{dt} \left( \frac{1}{2} C V_{dc}^2(t) \right) = - [V_{as} i_{as} + V_{bs} i_{bs} + V_{cs} i_{cs}] - \frac{V_{dc}^2(t)}{R_c} \quad (4)$$

In order to convert three phase ac currents into dc currents STATCOM internally contains dq transformation block. By using this abc/dq transformation, the above mentioned equations can be rewritten as:

$$\frac{d}{dt} \begin{bmatrix} i_{ds} \\ i_{qs} \\ V_{dc} \end{bmatrix} = \begin{bmatrix} -R_s/L_s & \omega & (K/L_s)\cos\alpha \\ -\omega & -R_s/L_s & (K/L_s)\sin\alpha \\ (-3K/2C)\cos\alpha & (-3K/2C)\sin\alpha & -1/R_c \end{bmatrix} \begin{bmatrix} i_{ds} \\ i_{qs} \\ V_{dc} \end{bmatrix} - \frac{1}{L_s} \begin{bmatrix} V_{dl} \\ V_{ql} \\ 0 \end{bmatrix} \quad (5)$$

In this equation  $i_{ds}$  and  $i_{qs}$  represents the direct axis and quadrature axis currents corresponding to STATCOM output currents;  $V_{dc}$  represents the dc voltage;  $\alpha$  represents the phase angle;  $\omega$  represents rotating angle;  $V_{dl}$  and  $V_{ql}$  are the direct and quadrature axis voltages belongs to  $V_{al}$ ,  $V_{bl}$  and  $V_{cl}$ . From reference [25],  $V_{ql}=0$ . Therefore

$$p_l = \frac{3}{2} V_{dl} i_{ds} \quad (6)$$

$$q_l = \frac{3}{2} V_{dl} i_{qs} \quad (7)$$

Based on these equations, STATCOM control strategy can be obtained. The dc side current equation can be written as:

$$i_{dc} = \frac{1}{\omega C} \frac{d}{dt} V_{dc} + \frac{V_{dc}}{R_c} \quad (8)$$

Where  $\omega$  is the angular speed at system nominal frequency and  $V_{dc}$  is the voltage across dc capacitor C. For the construction of HESS generally there are two different structures. In the first strategy battery straight forwardly associated with the dc bus and the super capacitor joined with the dc bus through a dc-dc converter which is bidirectional in nature [24]. The main disadvantage of this method is voltage levels of battery and dc bus should be same and also battery output power is uncontrollable. In the second method battery and super capacitor both are connected to the dc bus by utilizing two diverse dc-dc converters [25]. Advantage of this structure is it controls the storage elements power well by an excellent control system.

### 3. Model and Control of the HESS using Two DC-DC Converters

#### 3.1. Proposed Model

HESS using two dc-dc converters for STATCOM is shown in Figure 2. One dc-dc converter is embedded between the dc bus of the STATCOM and battery system and another one is between the SC and the dc bus. In view of the condition of charge of the super capacitors and the batteries, the power flow can be supplied or recovered by the batteries or by the super capacitor or by the both. Controlling of the bus is by the active dc-dc converters. All components in this model are joined by interaction principle. In this method these dc-dc converters depends only on  $V_{dc}$  of STATCOM so that there will be no change in the STATCOM control strategy.

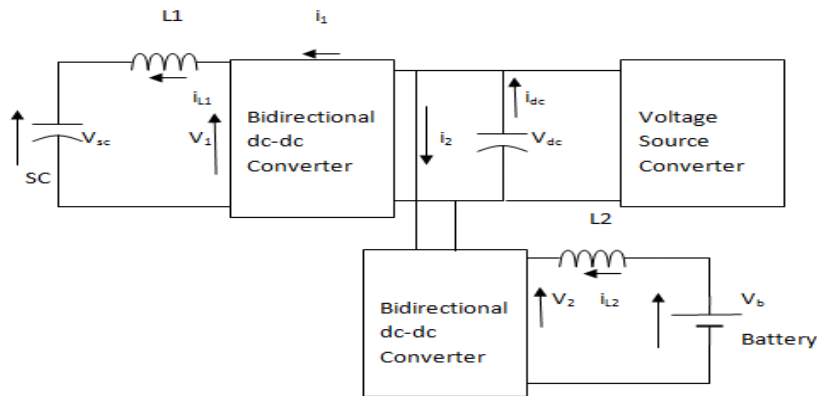

Figure 2. HESS for STATCOM

The output voltage of the dc bus is given by:

$$C \frac{d}{dt} V_{dc} = i_{dc} \quad (9)$$

Where C is dc bus capacitor and from the figure (2)

$$i_{dc} = i_1 + i_2 + i_{statcom} \quad (10)$$

By equating this equation with equation (8) we can write

$$i_1 + i_2 + i_{statcom} = \frac{1}{\omega C} \frac{d}{dt} V_{dc} + \frac{V_{dc}}{R_c} \quad (11)$$

From this equation current drawn by dc-dc converter which is connected to super capacitor is

$$i_1 = \frac{1}{\omega C} \frac{d}{dt} V_{dc} + \frac{V_{dc}}{R_c} - i_2 - i_{statcom} \quad (12)$$

And similarly current drawn by dc-dc converter which is connected to battery is

$$i_2 = \frac{1}{\omega C} \frac{d}{dt} V_{dc} + \frac{V_{dc}}{R_c} - i_1 - i_{statcom} \quad (13)$$

The average model of dc-dc converters are represented as

$$V_1 = m_1 V_{dc} \quad V_2 = m_2 V_{dc} \quad i_1 = m_1 i_{L1} \quad i_2 = m_2 i_{L2} \quad (14)$$

where  $m_1$  and  $m_2$  are the modulation functions of dc-dc converter 1 and 2.

$$\begin{aligned} L_1 \frac{d}{dt} i_{L1} + r_1 i_{L1} &= V_1 - V_{sc} \\ L_2 \frac{d}{dt} i_{L2} + r_2 i_{L2} &= V_2 - V_b \end{aligned} \quad (15)$$

Where  $L_1$  and  $L_2$  are the inductances and  $r_1$  and  $r_2$  are the internal resistances of the smoothing inductors. Super capacitors bank is represented by an electric circuit  $r_{sc}C_{sc}$ , which delivers the Super capacitor voltage  $V_{sc}$ .

$$V_{sc} = r_{sc} i_{sc} + \frac{1}{C_{sc}} \int i_{sc} \cdot dt \quad (16)$$

Where  $C_{sc}$  is the capacitance and  $r_{sc}$  is the internal resistance of the super capacitor. The state of charge (soc) of super capacitor is calculated by using the principle

$$SOC_{sc}(\text{percent}) = \frac{V_{sc}}{V_{sc,max}} \times 100 \quad (17)$$

Where  $V_{sc}$  is the SC voltage and  $V_{sc,max}$  is the maximum SC voltage. Battery bank is indicated by an electric source with internal resistors  $R_1, R_2 \dots$  etc. and capacitors  $C_1, C_2 \dots$  etc. The soc of battery is calculated by using columbic algorithm [24].

$$SOC_{Batt}(\text{percent}) = SOC_{Batt-init}(\text{per}) + \int \frac{i_{Batt}\eta}{C_n} \cdot dt \cdot \frac{100}{3600} \quad (18)$$

Where  $SOC_{Batt-init}$  is the initial state of charge,  $\eta$  is the faradic efficiency and  $C_n$  is the storage capacity of the battery.

DC-DC converter control strategy, due to its most popularity and advantage current mode control switching regulator is used in this model. This converter acts as buck-boost converter with the combination of proportional integral (PI) controller. The main advantage of this controller is to induce robust output voltage regulation during converter-parameter uncertainties and external disturbances. During boost mode control, the controller controls the discharge current with outer loop and controls the dc link voltage with inner loop. During buck mode control, the controller controls the charging current with outer loop and controls either battery or super capacitor voltage with inner loop. In both modes, inner loop is the current control loop and based on peak current control mode. The outer voltage controllers are conventional PI controllers for voltage regulation.

## 4. Simulation Results

### 4.1. Data of the Modeled System

A  $\pm 100$  MVAR rating STATCOM with 48 pulses VSC is shown in Figure 5. This is associated with a 500 kV bus. This simulation diagram is an example STATCOM system in Simulink examples library. All machines used in this system are dynamic models [25, 26]. This

same STATCOM system is designed with hybrid energy storage system called as S-HESS and which is shown in Figure 6. The system parameters for dc-dc converter series circuit are  $L=50\mu\text{H}$ , diode  $V_f = 0.8$ ,  $R_s = 500\text{ohms}$ ,  $C_s = 250\text{nF}$  and for parallel RLC branch  $R=0.1\text{ohm}$ ,  $C=220\ \mu\text{F}$ . For super capacitor rated capacity is taken as  $100\text{pF}$ , dc series resistance as  $2.1\text{m}\Omega$ , number of series capacitors as 6 and parallel capacitor as 1. For battery rated capacity is taken as  $1000\text{AH}$ .

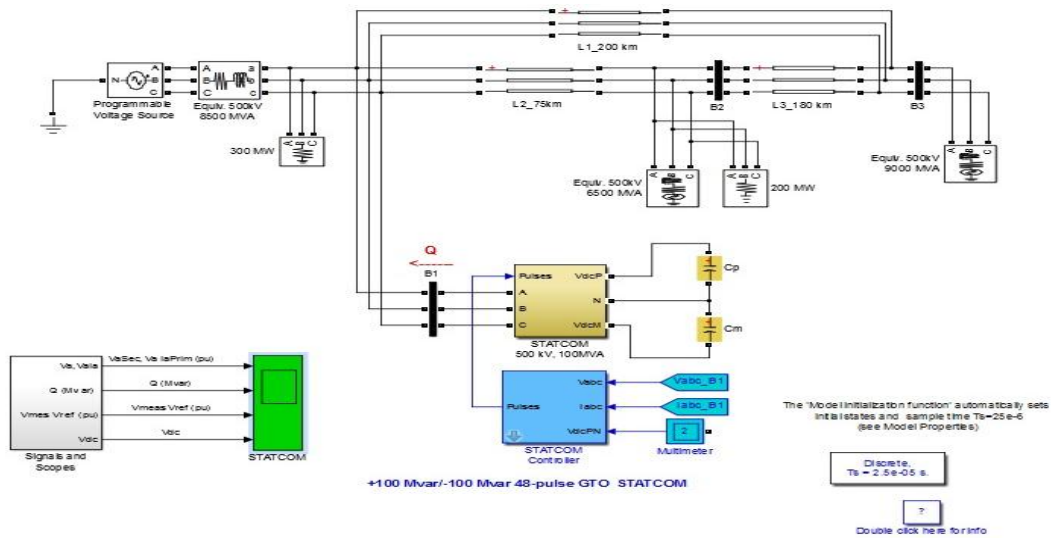

Figure 3. Normal STATCOM Design System

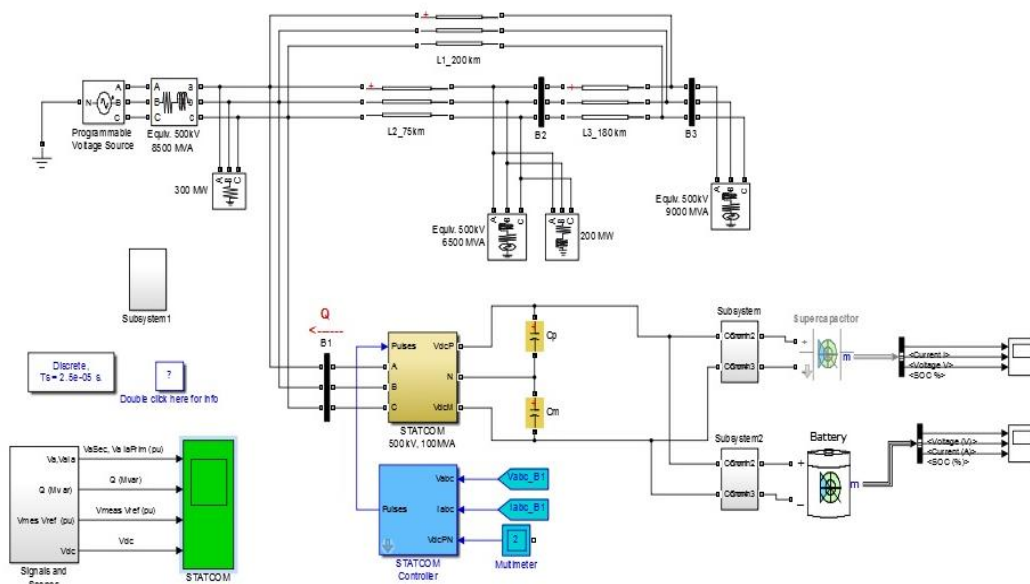

Figure 4. STATCOM with Hybrid Energy Storage System

#### 4.2. Study of STATCOM with HESS with Change of Load

In this section results are analyzed for four cases with sudden change of load at bus B2. By keeping all the parameters constant at 0.3 seconds, the load at bus B2 changes from 200MW to 400MW. In these four cases results are analyzed for STATCOM system with out any energy storage system, STATCOM with BESS, STATCOM with SCESS and STATCOM with HESS.

### Case1. STATCOM without any energy storage system

In this case power system was taken which was used in the previous model with out any energy storage element. At 0.12 sec system measured voltage fall down to 0.97p.u and injected reactive power reaches to 100Mvar. At 0.22 sec STATCOM bring the system voltage to 1.01p.u by injecting appropriate amount of reactive power. Suddenly at 0.3 sec due to sudden load at B2 again system voltage falls down to 0.98p.u. Results are shown in Figure 5.

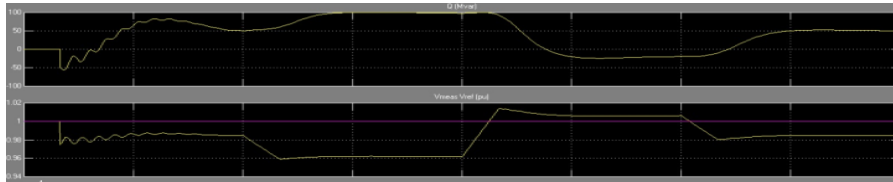

Figure 5. Injected/absorbed reactive power and measured/reference voltage for STATCOM without any energy storage

### Case2. STATCOM with BESS

In this case power system was taken with battery energy storage element. At 0.12 sec system measured voltage fall down to 0.98p.u and injected reactive power reaches to 90Mvar. At 0.22 sec STATCOM bring the system voltage to 1.015p.u by injecting appropriate amount of reactive power. Suddenly at 0.3 sec due to sudden load at B2 again system voltage falls down to 0.995p.u. Results are shown in Figure 6.

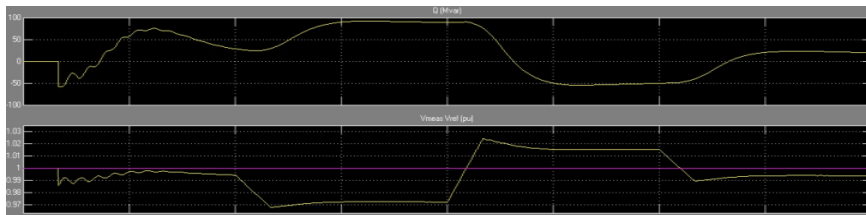

Figure 6. Injected/absorbed reactive power and measured/reference voltage for STATCOM with battery

### Case3. STATCOM with SCESS

In this case power system was taken with super capacitor energy storage element. At 0.12 sec system measured voltage fall down to 0.985p.u and injected reactive power reaches to 80Mvar. At 0.22 sec STATCOM bring the system voltage to 1.02p.u by injecting appropriate amount of reactive power. Suddenly at 0.3 sec due to sudden load at B2 again system voltage falls down to 0.997p.u. Results are shown in Figure 7.

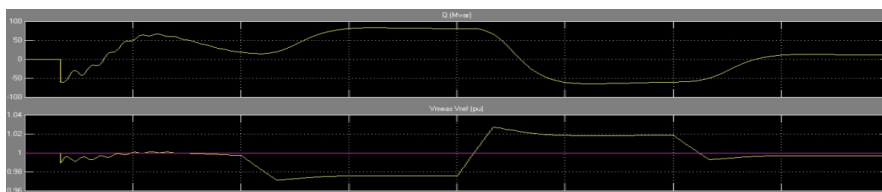

Figure 7. Injected/absorbed reactive power and measured/reference voltage for STATCOM with super capacitor

**Case4. STATCOM with HESS**

In this case power system was taken with hybrid energy storage system. At 0.12 sec system measured voltage fall down to 0.98p.u and injected reactive power reaches to 73Mvar. At 0.22 sec STATCOM bring the system voltage to 1.02p.u by injecting appropriate amount of reactive power. Suddenly at 0.3 sec due to sudden load at B2 again system voltage falls down to 0.997p.u and immediately at 0.336sec STATCOM system bring back to 1p.u. Results are shown in Figure 8.

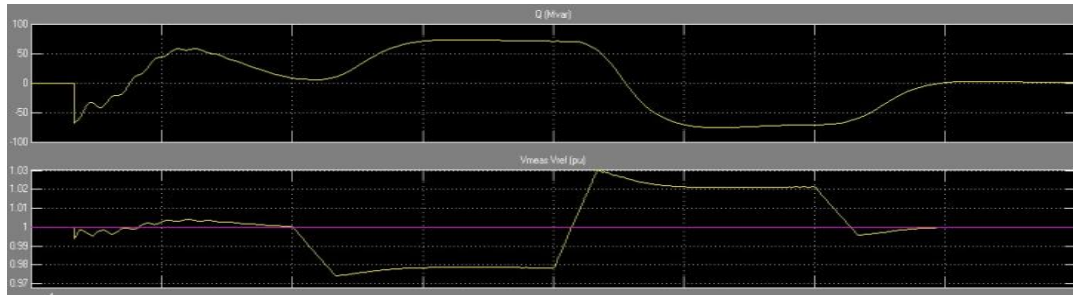

Figure 8. Injected/absorbed reactive power and measured/reference voltage for STATCOM with hybrid energy storage system.

**4.3. Summary and Analysis of the Study**

From the above four studies, it is evident that STATCOM with HESS provide more voltage stability under sudden load changes when compare to remaining three cases which is shown in Figure 9 which indicates the comparison of four cases. During consecutive sudden load changes at Bus B2 system voltage falls down to 0.97p.u at 0.12s and 0.98p.u at 0.3s for STATCOM system, system voltage falls down to 0.98p.u at 0.12s and 0.995p.u at 0.3s for STATCOM with BESS, system voltage falls down to 0.985p.u at 0.12s and 0.997p.u at 0.3s for STATCOM with SC. In these three cases system not able to bring back 1p.u even after 4seconds due to unavailability of sufficient amount of reactive power under consecutive load changes. Where as STATCOM with HESS system voltage falls down to 0.98p.u at 0.12s and 0.995p.u at 0.3s and again system back to 1p.u at 0.35s due to heavy compensation of reactive power.

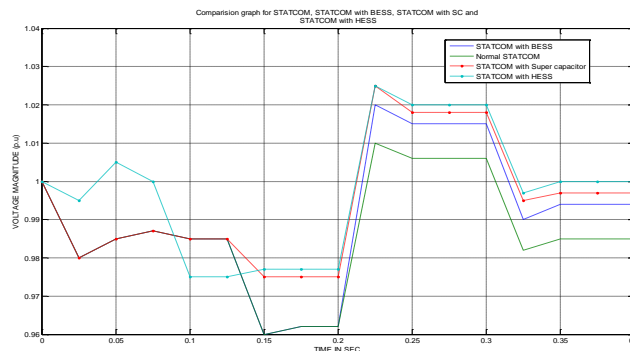

Figure 9. Comparison graph for STATCOM, STATCOM with BESS, STATCOM with super capacitor and STATCOM with HESS

**5. Conclusion**

In the previous work, STATCOM with various energy storage elements was discussed for voltage and system stability. Apart from these previous works, this paper introduces a new method of HESS for voltage stability. This design is more point of preference since battery power and super capacitor power can be controlled separately relying upon their condition of



charge and the supply requirements. A STATCOM system with battery and super capacitor is designed and results are verified with normal STATCOM. Results are also verified for this system under sudden load changes in four cases with different configurations. A comparison graph is drawn for all the four cases. From this study it is proved that STATCOM with HESS provide better voltage stability under sudden load change.

## 6. Future Work

Future work may lie in the study of STATCOM with HESS for different type of power system problems like oscillations damping, transient stability, wind turbines and smart grids.

## References

- [1] Z Yang, C Shen, L Zhang, ML Crow, S Atcitty. *Integration of STATCOM and battery energy storage*. *IEEE trans. Power systems*. 2001; 16(2): 254-260.
- [2] Kobayashi K, Goto M, Kaiwn, Yokomizu Y, Matsumura T. *Power system stability improvement by energy storage type STATCOM*. IEEE power tech. conference proceedings. Bologna. 2003; 2.
- [3] Srithorn P, Sumner M, Yao L, Ram Parashar. *The control of a STATCOM with super capacitor energy storage for improved power quality*. CIRED conference on Smart grids for distribution. Frankfurt. 2008.
- [4] Hossain MJ, Pota HR, Ramos RA. Improved low voltage ride through capability of fixed wind turbines using decentralized control of STATCOM with energy storage system. *IET generation, transmission & distribution*. 2012; 6(8): 719-730.
- [5] Sheik MRI, Eva F, Motin MA, Hossian MA. *wind generator output power smoothing and terminal voltage regulation by using STATCOM/SMES*. IEEE conference on the development in Renewable energy technology (ICDRET). 2012: 1-5.
- [6] Virtaner A Tuusa H, Aho J. *Performance analysis of conventional STATCOM and STATCOMS with energy storage*. Electric arc furnace applications. IEEE conference on Applied power electronics conference and Exposition (APEC). 2013: 1623-1629.
- [7] Lirong zhang, yiwang, Heming Li, pinsuu. *Hybrid power control of cascaded STATCOM/BESS for wind farm integration*. IEEE conference on industrial electronics society, IECON. 2013: 5288-5293.
- [8] Aarathi AR, Jayan MV. *Grid connected photovoltaic system with super capacitor energy storage and STATCOM for power system stability enhancement*. IEEE conference on Advances in Green energy (ICAGE). 2014: 26-32.
- [9] Mathew B, Varghese J. *Electric vehicle as STATCOM and real power flow controller for energy conversion system*. IEEE conference on Emerging Research areas: Magnetics, Machines and drives (AICERA/ICMMD). 2014: 1-4.
- [10] Beza M, Bongiorno M. An Adaptiv power oscillation damping controller by STATCOM with energy storage. *IEEE transactions on power systems*. 2016; 30(1): 484-493.
- [11] PF Ribair, BK Johnson, ML Crow, A Arbo, Y Lin. *Energy storage systems for advanced power applications*. Proc. IEEE. 2001; 89(12): 1744-1756.
- [12] Zhenging Xi, parkhideh B, Bhattacharys S. *Improving distribution system performance with integrated STATCOM and super capacitor energy storage system*. IEEE power electronics specialists conference. 2008.
- [13] AHMA Rahim, M Ahasanul Alam. STATCOM – Super capacitor control for low voltage performance improvement of wind generation system. *Arabian Journal of science and engineering*, Springer publications. 2013; 38(11): 3133-3143.
- [14] Anju M, Rajasekharan R. *Coordination of SEMS with STATCOM for mitigating SSR and damping power system oscillations in a series compensated wind power system*. IEEE international conference on Computer Communication and Informatics (ICCCI). 2013: 1-6.
- [15] Maleki H, Varma RK. *Comparative study for improving damping oscillation of SMIB system with STATCOM and BESS using remote and local signal*. IEEE 28<sup>th</sup> Canadian conference on Electrical and Computer Engineering (CCECE). 2015: 265-270.
- [16] Baros S Llic MD. *Multi-objective Lyapunov – based control of a STATCOM/BESS*. IEEE Power and Energy society Innovative Smart grid Technologies conference (ISGT). Washington DC. 2015: 1-5.
- [17] Kanchanaharuthai A, Chankong V, Loparo KA. Transient stability and voltage regulation in multi machine power system vis-à-vis STATCOM and Battery energy storage. *IEEE Transactions on power systems*. 2015; 30(5): 2404-2416.

- [18] Ghorbanian MJ, Goodarzvand F, Povdaryaei A, Mahadi WNL. *Power quality improvement of grid connected double fed induction generator using STATCOM and BESS*. 4<sup>th</sup> International Conference on Engineering Technology and Technopreneuship (ICE2T). 2014; 110-115.
- [19] Li Ning-Ning, Liu Yi-qi, Ji Yan-chao, Wang-Jian-Ze. *Power fluctuation alleviation using cascade STATCOMs with energy storages for wind farm applications*. 17<sup>th</sup> IEEE International conference on Electrical Machines and Systems (ICEMS). 2014: 1334-1339.
- [20] Mohammed A Badr, Ahmad M Atallah, Mona A Bayoumi. Performance analysis of SMES integrated with wind farms to power systems through MT-HVDC. *Indonesian Journal of Electrical Engineering and Computer science*. 2016; 4(1): 1-9.
- [21] Ahmad Fatehmohamed Nor, Marizan Sulaiman, Aida Fazliana Abdul Kadir, Rosli Omar. Voltage Instability analysis for electric power system using voltage stability margin and modal analysis. *Indonesian Journal of Electrical Engineering and Computer science*. 2016; 3(3): 655-662.
- [22] P Rao, ML Crow, Z Yang. STATCOM control for power system voltage control applications. *IEEE Transactions on power delivery*. 2000; 15(4): 1311-1317.
- [23] C Schander, H Metha. *Vector analysis and control of the advanced static VAR compensators*. Proc. Inst. Elect. Eng. Gen. Transm. Distribution. 1993; 140(4): 299-306.
- [24] B Wu, F Zhuo, F Long, W Gu, Y Qing, Y Liu. *A management strategy for solar panel-battery- super capacitor hybrid energy system in solar car*. Proc. IEEE 8<sup>th</sup> Int. conf. power Electron. ECCE Asia. 2011: 1682-1687.
- [25] W Jiang, B Fahimi. Multiport power electronic interface concept, modeling and design. *IEEE Trans. Power Electron*. 2011; 26(7): 1890-1900.
- [26] S Pang, J Farell, J Du, M Barth. *Battery state of charge estimation*. IEEE Proceedings of the American control conference, Arlington, USA. 2001.
- [27] MSE Moursi, AM Sharaf. Novell controllers for the 48 pulse VSC STATCOM and SSSC for Voltage regulation and reactive power compensation. *IEEE trans. Power syst*. 2005; 20(4): 1985-1997.
- [28] Matlab & Simulink, GTO based STATCOM, Dec 2013, [www.mathworks.com](http://www.mathworks.com)