

Virtual Laboratory of Unbalanced Transient Condition in Synchronous Generator

Sugiarto Kadiman*, Arif Basuki, Diah Suwarti

Departement of Electrical Engineering, Sekolah Tinggi Teknologi Nasional (STTNAS), Jalan Babarsari
Caturtunggal, Depok, Sleman, Yogyakarta

*Corresponding author, e-mail: sugiarto.kadiman@sttnas.ac.id

Abstract

The electrical engineering department at the Sekolah Tinggi Teknologi Nasional (STTNAS), Yogyakarta has recently reconnoitered virtual laboratories for its undergraduate synchronous generator course to complement existing full-scale laboratory equipment. This study explores virtual laboratory development to be treated as an accessorial tool for enhancing instruction. The focus of this synchronous generator course is the dynamic transient behavior of the system after small disturbances as affected by the unbalanced load. The work is mainly carried out through nonlinear simulations under Matlab-Simulink. Results of the first version of the synchronous generator virtual laboratory and details of its development are provided.

Keywords: virtual laboratory, synchronous generator, transient state condition, unbalanced load

Copyright © 2017 Institute of Advanced Engineering and Science. All rights reserved.

1. Introduction

In Indonesia, significant percentages of the undergraduate students in electrical engineering are working in industry. To meet with the students' need to expert conception while experimentations support the understanding of the topics, written exercises are required for those students. Real experiments are keys to develop skills dealing with physical processes [1, 2]. The laboratory education in the case of synchronous generator course is difficult, especially on the specific condition such as transient condition, at the undergraduate level because modernization of machine laboratories need high investment cost. As an alternative, virtual Laboratory can be treated as an accessorial tool of real laboratory to enhance instruction for conventional on-campus students; in which students can enable to improve the skills before going to the actual laboratory, to learn breaking the restriction of ordinary arrangement and enhance the instruction [3, 4].

The studies of dynamic synchronous generator date back from the time when the first power systems began to operate, and to start its interconnection process. The excessive advances regarding to such topics have been made since then, with the purpose of describing in detail the synchronous generator dynamics as affected by small disturbances, where the system in ordinarily unbalanced under steady-state conditions. From the transient stability perspective, several studies have already been accomplished during the 1980s in view of the unbalanced system in the dynamic of asynchronous generator following a system disturbance [5-7]. This transient phenomenon of a power system utilizing synchronous generator as a source of electrical energy is usually analyzed by employed single machine infinite bus taken to a balanced power system [8, 9]. The results are frequency (f) and damping ratio (ξ) of the electromechanical model calculated in each studied case of unbalanced scenario.

Relatively little concern has been paid to the dynamic behavior of an unbalanced system considered to small-signal behavior. The model solution is relatively difficult considering analysis given starts with equations containing the phase quantities and transforms them into new equations using α , β components. They are linear differential equations but the coefficients are variable. In [10], the model developments use the linearized state-space model and are related to DG facilities connected to distribution grids. Several simplifications are applied to this analysis, such as the electric power system is considered as a balanced three-phase system so it allows being represented by its single-phase equivalent. For all that, it is said that the modeling

approach presented here can be applied to any power system, regardless of size and/or voltage level.

Synchronous machines are usually employed as generators connected to a power system. In the current IEEE Standard [11], it is acknowledged that synchronous machines may be accurately modeled by two lumped-parameter equivalent circuits representing the q and the d axis. The number of rotor damper branches are selected in accordance with the rotor design. In low-order models, these branches correspond to the actual *amortisseur* windings; higher order models utilize these branches to represent the distributed effects in the rotor iron. To minimize the effort spent on setting up the model, it also takes advantage of simplifications that are offered by the separation in time scales of the different dynamic behaviors and the fact that the severity of a disturbance is usually attenuated as it propagates through the system. For example, the duration of the electrical transient of the network is very short relative to the electromechanical dynamic of the generator; as such, a static representation of the network can be used where longer electromechanical oscillations are primarily of interest. On the other side, the duration of interest may not be long enough to require the inclusion of the dynamic of slower acting component, such as automatic generation control. The model chosen for the generators on the network need not be the same; it only has to be compatible with the networks representation in the context of the solution algorithm used. If the type and location of the disturbances are to be known, one can selectively employ a detailed model for generators electrically close to the fault locations, and choose simpler models for generators further away. For example in [12], the phenomenon of interest is the transients in machines. The electromechanical transient occurs mainly in machines, ignoring the faster transients in lines and load reactances. This simplification is acceptable; this has an advantage of computational efficiency.

With the intention of helping to increase the knowledge about the dynamic behavior of synchronous generator after small disturbances, this study presents a thorough study concerning the dynamic behavior of unbalanced transient state synchronous generator model. The work is mainly carried out through nonlinear simulations under Matlab-Simulink [13-18], where the unbalanced power systems are calculated through the EDSA 2000 [19].

This work is organized as follows. A research method is presented on Section 2. Section 3 presents research and analysis, whereas the conclusion followed by the references is presented on Section 4.

2. Research Method

The system of this study is the single machine infinite bus (SMIB) shown Figure 1. The external line parameters, r_e and x_e , are to be varied to change the electrical strength of the connection between generator and infinite bus. In this case, the infinite bus supposedly represents a large system to which the generator is connected [20, 21]. In Figure 1, there is only single machine and a simple external network. So, it can easily transform variables of external network to the rotor reference frame of that single machine. If voltage drop across external line is:

$$V_z = (r_e + jx_e)I \quad (1)$$

Then the stator voltage equations with the external impedance included would become

$$v_q = -(r_s + r_e)i_q - (x'_d + x_e)i_d + E'_q \quad (2)$$

$$v_d = -(r_s + r_e)i_d - (x'_q + x_e)i_q + E'_d \quad (3)$$

where v_q , v_d , i_q , i_d are stator voltages and stator currents of both q -axis and d -axis, respectively. Using transient model, Equation (2) and (3) will be changed and the parameters of synchronous generator model will neglect the changes in stator $qd0$ flux linkages, shown in Table 1. All of objects in Table 1 are the forming components of synchronous generator model.

Figure 2 shows unbalanced three-phase synchronous generator that connected to infinite bus using series RL line coupling. The voltage components of infinite bus in the form of

$qd0$ reference framework are transformed into rotor reference framework using abc to $qd0$ converter.

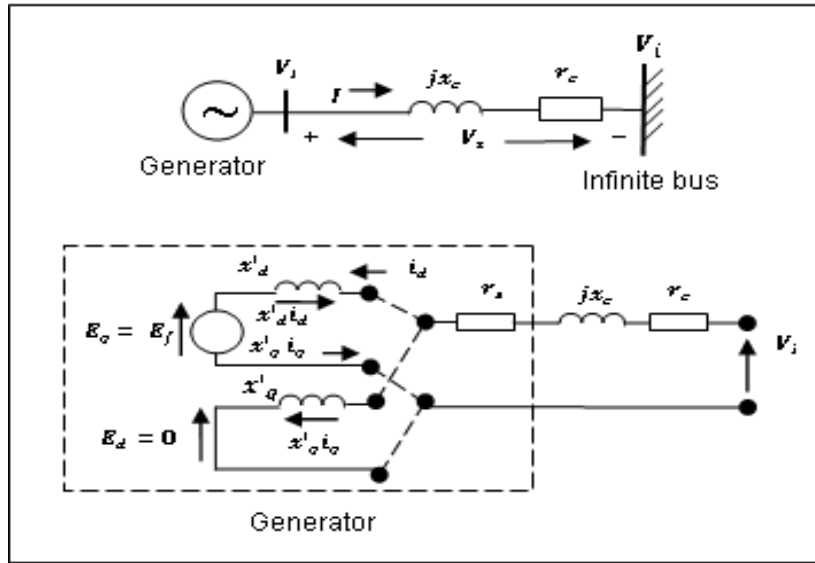

Figure 1. Single Machine Infinite Bus System

Table 1. Transient Generator Model with Changes in Stator $qd0$ Flux Linkages Neglected [22]

No.	Object	Equation
1	Stator winding	$v_q = -r_s i_q - x'_d i_d + E'_q V \text{ or } p.u$ $v_d = -r_s i_d - x'_q i_q + E'_d V \text{ or } p.u$
2	Rotor winding	$T'_{d0} \frac{dE'_q}{dt} + E'_q = E_f - (x_d - x'_d) i_d$ $T'_{q0} \frac{dE'_d}{dt} + E'_d = E_g - (x_q - x'_q) i_q$ <p>with</p> $\lambda'_q = \lambda_q - L'_q (-i_q) E'_d = -\omega_e \lambda'_q$ $\lambda'_d = \lambda_d - L'_d (-i_d) E'_q = -\omega_e \lambda'_d$
3	Mechanical torque	$T_{em} = -\frac{3}{2} \frac{P}{2\omega_e} \{E'_q i_q + E'_d i_d + (x'_q - x'_d) i_d i_q\} \text{ N.m}$ $= -\{E'_q i_q + E'_d i_d + (x'_q - x'_d) i_d i_q\} \text{ p.u}$
4	Rotor	$j \frac{d\omega_{rm}}{dt} T_{em} + T_{mech} - T_{damp} = 2H \frac{d\{(\omega_r - \omega_e)/\omega_b\}}{dt} \text{ N.m}$ $= T_{em(p.u)} + T_{mech(p.u)} - T_{damp(p.u)}$ $\frac{d\delta_e}{dt} = \omega_r - \omega_e \omega_r = \frac{P}{2} \omega_{rm}$

An inside the model box of three-phase synchronous generator of Figure 2 is shown in Figure 3. While the inside model box of stator winding is shown in Figure 4. The stator $qd0$ currents are determined using the stator voltage equations that included the external series RL line parameters in series with stator resistance and leakage reactance. And two rotor circuits are represented by the differential equation in E'_q and E'_d . Only the physical field winding on the d -axis has an external excitation of E_f ; that for the q -axis, E_g is zero.

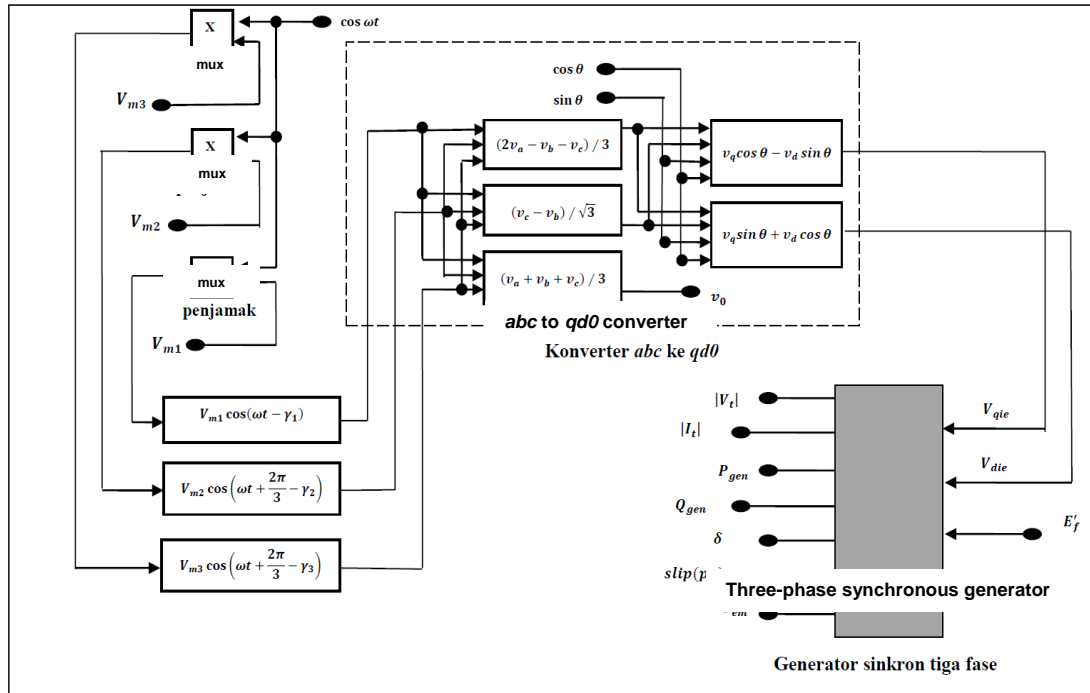

Figure 2. Unbalanced Transient Generator Model using SMIB with $V_{m1} \neq V_{m2} \neq V_{m3}$ and $\gamma_1 \neq \gamma_2 \neq \gamma_3$ [14]

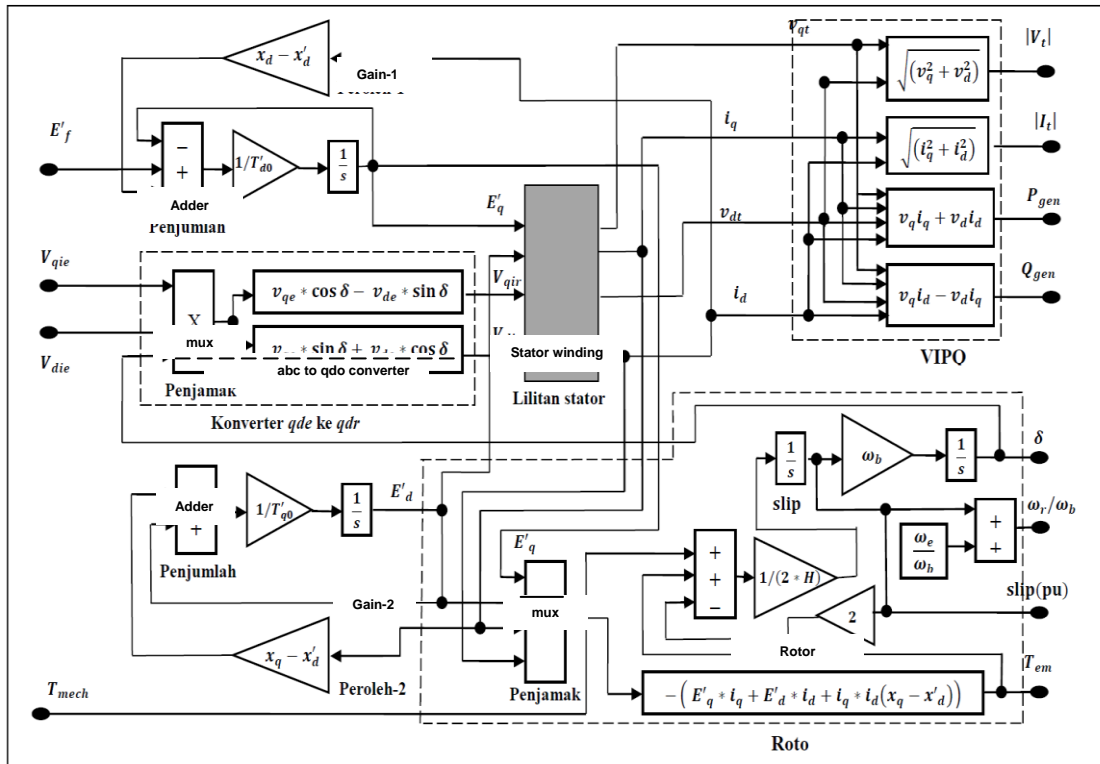

Figure 3. Inside the Model Box of Three-Phase Synchronous Generator

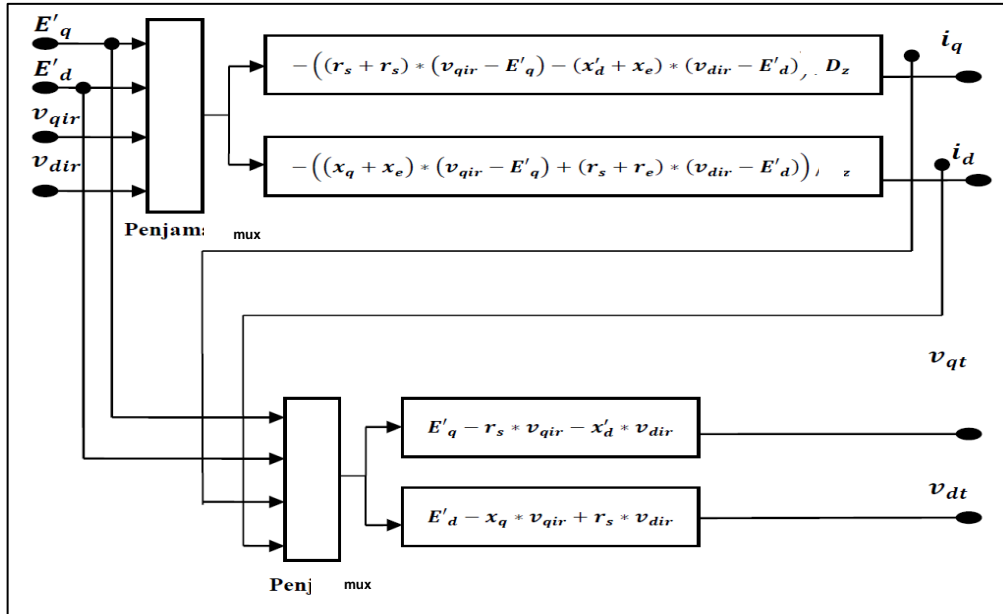

Figure 4. Inside the Model Box Of Stator Winding

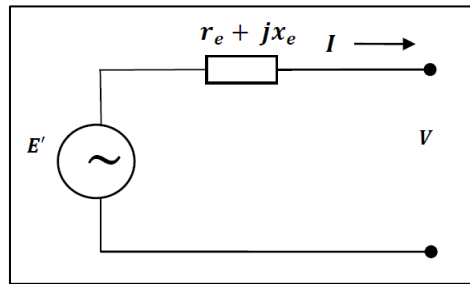

Figure 5. Model of Voltage is Phasor Lagging To Transient Impedance

The dynamic characteristic of SMIB is represented using the voltage E' that lagging by transient impedance $r_e + jx_e$, shown in Figure 5. And the dynamic equation of rotor per unit can be described using the relationship between rotor angle δ and rotor speed δ_0 ,

$$\frac{1}{\omega_b} \frac{d^2\delta}{dt^2} = \frac{1}{2H} (T_{mech} + T_{em} + T_{damp}) \tag{4}$$

where T_{mech} , T_{em} , and T_{damp} are mechanic, electric, and damping torques, respectively; while ω_b and H are base rotor speed and inertia constant. To change T_{em} into $-(EI)$ and put small disturbance into working point variable and rotor angle into δ_0 position will yield,

$$\frac{1}{\omega_b} \frac{d^2\Delta\delta}{dt^2} = \frac{1}{2H} \left\{ \underbrace{\Delta T_{mech} - \frac{E'V_\infty}{X} \cos \delta_0 \Delta\delta - D_\omega \Delta \left(\frac{\omega_r - \omega_b}{\omega_b} \right)}_{K_S} \right\} \tag{5}$$

where K_S is synchronization torque constant. Applying Laplace transform into Eq. (5) will result

$$s^2\Delta\delta + \frac{D_\omega\omega_b}{2H} s\Delta\delta + \frac{K_S\omega_b}{2H} \Delta\delta = \frac{\omega_b}{2H} \Delta T_{mech} \tag{6}$$

Comparing it with the normal quadratic square equation, $s^2 + 2\xi\omega_n s + \omega_n^2$, that has the root values of $-(\xi \pm j\sqrt{(\xi^2 - 1)}\omega_n)$ so the equation of undamped frequency will have the values of

$$\omega_n = \sqrt{\frac{K_S \omega_b}{2H}} \quad \xi = \frac{\omega_b}{2H} \left(\frac{D_\omega}{2H} \right) = \frac{1}{2} \frac{D_\omega}{\sqrt{2H \omega_b K_S}} \quad (7)$$

The value of K_S is inversely proportional with total reactance between E' and V_∞ .

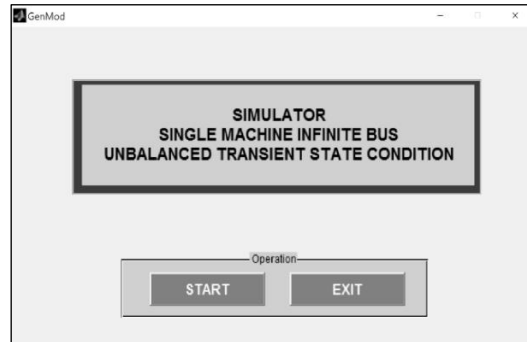
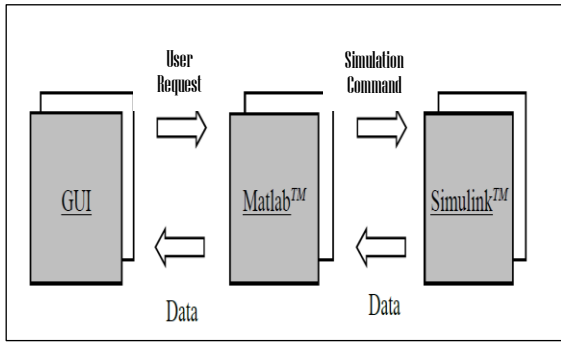

Figure 6. Architecture of Unbalanced Transient Figure 7. The Main Window of the Developed State Generator Simulator Software Tool

One can access Matlab's GUI facilities to construct a software package of virtual laboratory for studying synchronous generator under unbalanced transient-state condition. As an example of using Matlab's GUI capabilities, menu and plotting commands are implemented in a script file to provide interactive windows (Figure 6). The main menu, which is displayed after running the file, are shown in Figure 7 and Figure 8.

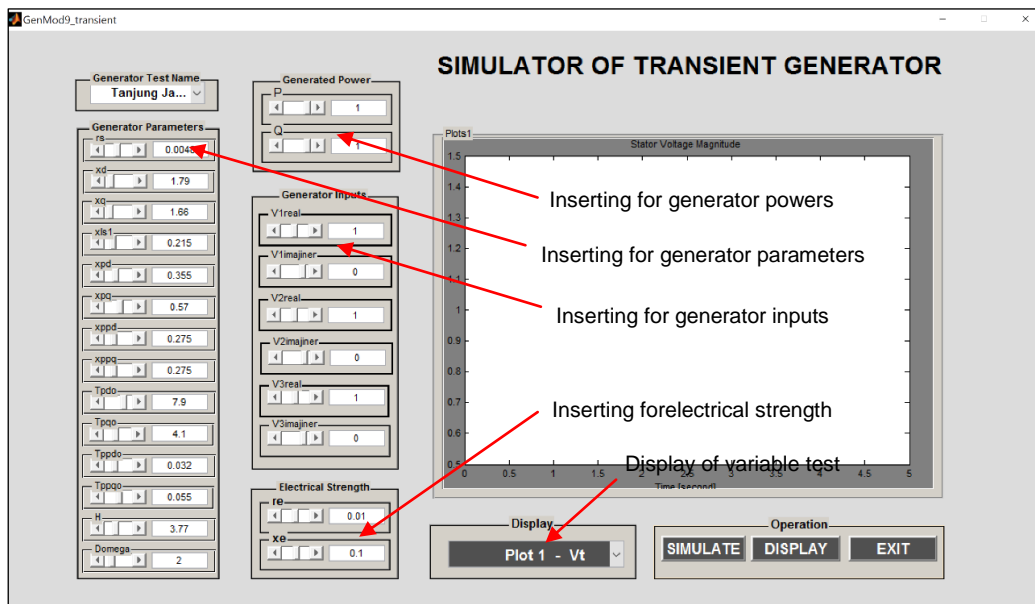

Figure 8. The Window of Inserting the Inputs and Displaying the Variable Tests

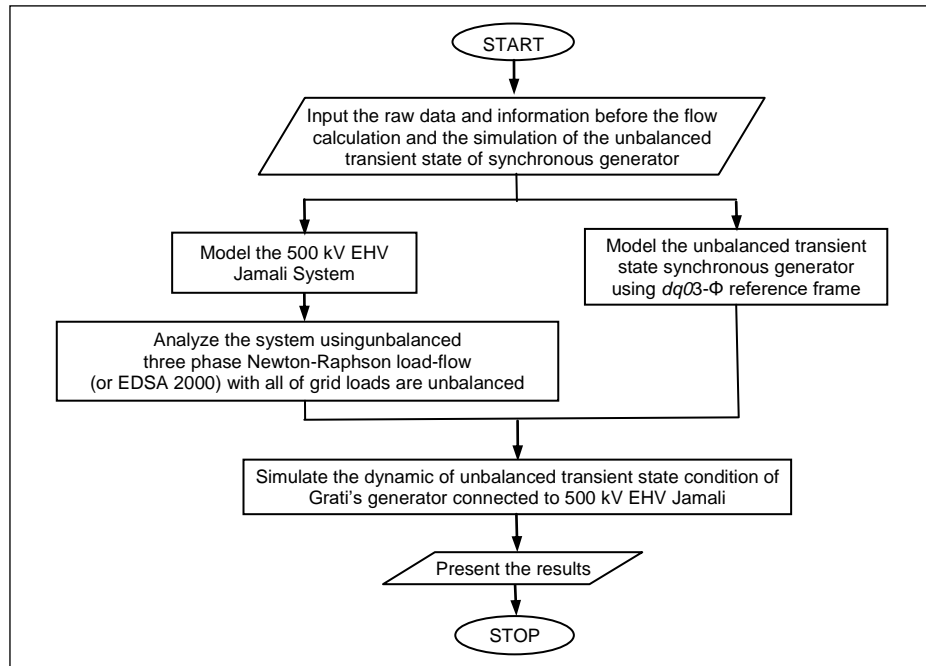

Figure 10. Simulation Flowchart

Table 3. Values of Generator Terminal Voltages [22]

Conditions of synchronous generator	Phase	Voltages of Tanjung Jati B [p.u]
Connected the grid and load balance	A	$1 \angle -5,8^{\circ}$
	b	$1 \angle 114,2^{\circ}$
	c	$1 \angle 234,2^{\circ}$
Connected the grid and load imbalance of 7,5%	a	$1 \angle -6,0^{\circ}$
	b	$1 \angle 114^{\circ}$
	c	$1 \angle 234^{\circ}$

This study is carried out utilizing the created GUI windows. Running the created GUI M-file, called "AwalGenMod", from Matlab workspace will display the main window shown in Figure 7. The window presented in Figure 8 will appear after clicking on the icon named *START*. Setting the slider icons of generator's parameters and typical stator voltages and also clicking on the icon named *SIMULATE* will present the result menu shown in Figure 7. This leads to the following figures which present the real and reactive powers, the current and the voltage, power angle, and electric torque.

In Figure 11, it can see when the synchronous generator connects and delivers energy to the 500 kV EHV Jamali System as much as $P + jQ = (1 + j1)$ p.u, its current in phase could become unbalanced even though all of the grid loads are balanced. Moreover, the generated active and reactive powers will become slightly to oscillate but the rotor speed tends to be constant. And the power angle peak goes up to 1.04 p.u.

As the level of unbalance is increasing up to 7.5%, the currents in phase are still unbalanced. Comparing among figures observably that the increasing of unbalanced percentage of load has an effect on the decreasing and oscillating of the generated active and reactive powers, the power angle and the magnitude of stator current oscillation, and the electric torque. On the contrary, it has no effect on the speed of the machine's rotor; the rotor speed is always constant.

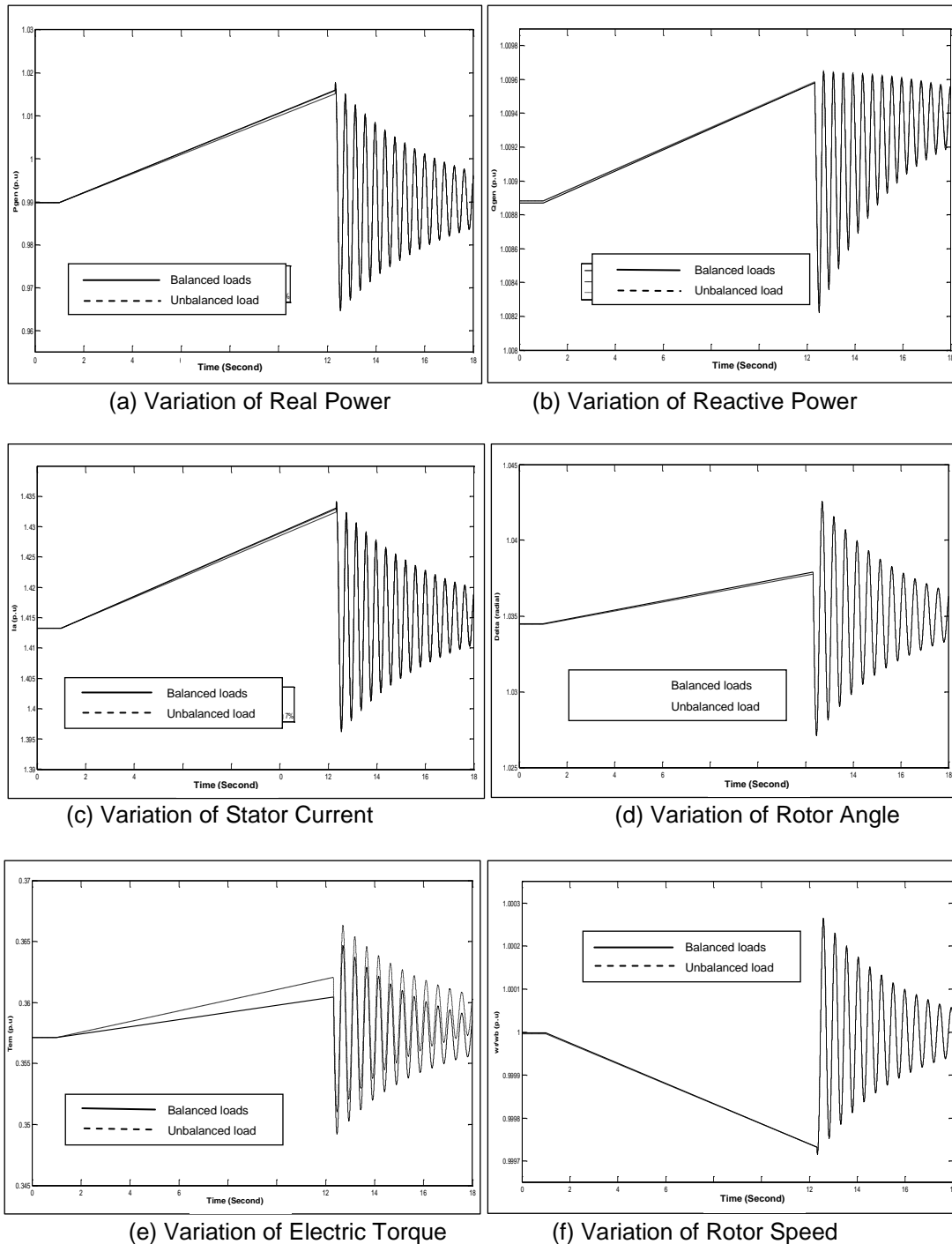

Figure 11. Transient State Synchronous Generator Responses under Unbalanced Loads

4. Conclusion

A useful approach for studying unbalanced transient state operation of synchronous generator under has been presented in this paper. Two operation conditions of the synchronous generator, balanced load and 7.5% of unbalanced load, are mathematically modeled then simulated using Matlab. The simulation results state that the increasing level of unbalanced load has significant influence on the parameters of generator dynamic regarding decreasing and oscillating of its magnitudes, except to the rotor speed. The proposed tool is made easy to use by providing an active link with the simulated models using some of GUI functions. The given

examples demonstrate helpfulness of the proposed tool for studying the synchronous generator dynamic under unbalanced transient state condition.

Acknowledgements

The authors are thankful to the Indonesian Directorate General of Higher Education (DIKTI) for funding this project (in the form of Competitive Research Grant or *Penelitian Hibah Bersaing*) No. SP DIPA-042.06-0.1.401516/2016. And also to the Head of *Pusat Penelitian dan Pengabdian pada Masyarakat (P3M)* Sekolah Tinggi Teknologi Nasional (STTNAS) Yogyakarta and the Head of Electrical Department, STTNAS, Yogyakarta for providing required facilities

References

- [1] Menéndez LM, Mandado E, Salaverria A, Dacosta JG. *Virtual Electronics Laboratory: A New Tool to Improve Industrial Electronics Learning*. IECON 2006 32nd. 2006: 5445-5448.
- [2] Yan L, Dongmei W. *Simulation of Synchronous Generator's Dynamic Operation Characteristics*. The Tenth International Conference on Electronic Measurement & Instruments – ICEMI. 2011.
- [3] Teodorescu R, Iov F, Lungeanu F, Tataru AM, Dumitriu T, Panaitescu R. The Development of a Simulink Toolbox. Optimization of Electrical and Electronic Equipment's. 1998: 574-576.
- [4] Ruiz D, Asian TI, Olguin D. *Teaching and Research Laboratory Simulator of Electric Power Systems*. 29th ASEE/IEEE Frontiers in Education Conference. Nov.10-13, 1999:11b6-8 – 11b6-14.
- [5] Makram EB, Zambrano VO, Harley RG, Balda JC. Three-phase Modeling for Transient Stability of Large Scale Unbalanced Distribution Systems. *IEEE Trans. On Power Systems*. 1989; 4(2): 487-493.
- [6] Bai X, Jiang T, Guo Z, Yan Z, Ni Y. A unified Approach for Processing Unbalanced Conditions in Transient Stability Calculations. *IEEE Trans. Power Systems*. 2006; 21(1): 85-90.
- [7] Edwards FV, Dudgeon GJW, Mc Donald JR, Leithead WE, *Dynamics of Distribution Networks with Distributed Generation*. IEEE PES Summer Meeting. 2000; 2: 1032–1037.
- [8] Fodor A, Magyar A, Hangos KM. *Dynamic Modelling and Model Analysis of a Large Industrial Synchronous Generator*. International Conference on Applied Electronic. 2010: 1-6
- [9] Ghfarokhi GS, Arezoomand M, Mahmoodian M. *Analysis and Simulation of the Single-Machine Infinite-Bus with Power System Stabilizer and Parameters Variation Effects*. International Conference on Intelligent and Advanced Systems. 2007: 167-171.
- [10] Salim RH, Ramos RA, Bretas NG. *Analysis of the Small Signal Dynamic Performance of Synchronous generators under Unbalanced Operating Conditions*. Power and Energy Society General Meeting. 2010:1-8.
- [11] IEEE PES. IEEE Std 1110™-2002. *IEEE Guide for Synchronous Generator Modelling Practices and Applications in Power Stability Analysis*. The IEEE, Inc. New York. 2003.
- [12] Elizondo MA, Tuffner FK, Schenider KP. Three-Phase Unbalanced Transient Dynamics and Powerflow for Modeling Distribution Systems With Synchronous Machines. *IEEE Transac. On power Systems*. DOI: 10.1109/TPWRS.2015.2389712
- [13] Narayanan, G, Despanthe, A, Narayanan, A. *Realistic Experience without Risk using Virtual Electrical Machines Laboratory*. International Conference on Learning and Teaching in Computing and Engineering. 2016: 132-133.
- [14] Sugiarto, Hadi SP, Tumiran, Wijaya FD. *Teaching the Large Synchronous Generator Dynamic Model under Unbalanced Steady-State Operation*. The 5th International Conference on Information Technology and Electrical Engineering (ICITEE). 2013: 425-429.
- [15] Kadiman S, Basuki A, Arena M. The Dynamic of Synchronous Generator under Unbalanced Steady State Operation: A Case of Virtual Generator Laboratory. *International Journal of Electrical and Computer Engineering (IJECE)*. 2015; 5(6): 1292-1303.
- [16] Kumari JS, Babu CS. Mathematical Modeling and Simulation of Photovoltaic Cell using Matlab-Simulink Environment. *International Journal of Electrical and Computer Engineering (IJECE)*. 2012; 2(1): 26-34.
- [17] Ajenikoko GA, Olaomi AA. A Model for Assessment of Transient StabilityOf Electrical Power Systems. *International Journal of Electrical and Computer Engineering (IJECE)*. 2014; 4(4): 498-511.
- [18] Louzazni M, Aroudam EH, Yatimi H. Modeling and Simulation of A Solar Power Source for a Clean Energy without Pollution. *IJECE*. 2013; 3(4): 568-576.
- [19] EDSA Technical 2000. Available: <http://www.edsa.com>.
- [20] Kundur P. *Power System Stability and Control*. Mc-Graw-Hill, Inc. New York. 1994: 727-737.
- [21] Padyar KR. *Power System Dynamic, Stability and Control*. 2nd Edition. BS Publikans. Hyderabad. 2008: 177-218.
- [22] Sugiarto. The Influence of Unbalanced Loads on Stability of Generator under Steady State and Transient Conditions. PhD Thesis. Postgraduate Program, Gadjah Mada University, Yogyakarta. 2014.