

Total Harmonic Distortion at Fault in RLC Load

Pankaj Aswal*, Suyash Kumar Singh, Niharika Agarwal, Vivek Sharma, Gayatri Sharma

Department of Electrical & Electronics Engineering, Graphic Era University

*Corresponding author, e-mail: id-aswal_pankaj@rediffmail.com

Abstract

This paper focuses on the calculation of total harmonic distortion (THD) at various fault situations in case of RLC load. The faults are created by introducing heavy impedance of 1000 ohm, by blowing off the gate pulse at one of the terminals of the mosfet, and by introducing a line to ground fault. The Matlab based simulation has been done to show these effects.

Keywords: total harmonic distortion (THD), mosfet, fault, frequency

Copyright © 2016 Institute of Advanced Engineering and Science. All rights reserved.

1. Introduction

The total harmonic distortion, or THD, of a signal is defined as the measure of the harmonic distortion present in the signal and is the ratio of the sum of the powers of harmonic components to the power of the fundamental frequency. THD is used to define the quality of power in electric power systems. In power systems, the decrease in the value of THD leads to reduction in peak currents, heating, and core loss in motors [1-3], [7].

When we talk about electric motors or electrical generators, we think that the speed of rotation of these electrical machines is monitored only by the voltage and frequency of the source current applied to the machines. But the speed of rotation these machines can be controlled by applying the concept of drive. The advantage of using drives is the motion of the machines can be controlled easily by making the use of drive. In other words, the systems which control the motion of the electrical machines are known as electrical drives [2], [4], [6].

Here we have made the use of the RLC load in order to study how the system gets affected when different types of faults occur in the circuit, i.e. how the THD (Total Harmonic distortion) gets affected in case of various sorts of faults [3], [5].

The ED problem is the multi-dimension that is suitable the number of unit generator. This is challenge of the CFS method for solving the ED problem. The paper will develop the CFS for Multi Dimension CFS, MD-CFS. The methodology will be described clearly, where the dimensions are decomposed into two or three dimensions, for example 7 dimensions will be decomposed into 2 parts of two dimensions and 1 part of three dimensions. Furthermore, the method will be tested by 8 generators, 8 dimensions.

2. Simulated Model

Here we have simulated our paper under various fault condition and without any fault condition for the simulation we use power electronics diode four in numbers to use it as rectifier. The simulated model contains pi filter to improve the quality of the input power supply. Then we use the set of six mosfet as a voltage source inverter.

3. Conditions under Observations

In the present work, simulation studies have been performed on a 3-phase Brushless dc motor. The fault in the simulation model is created in the following ways.

1. No fault is introduced.
2. No gate pulse at one of the six MOSFET gate terminals.
3. Blowing off one MOSFET in the VSI inverter by introducing a resistance of 1 kilo ohm.
4. Line to ground fault at one of the motor terminals

4. Simulation Result

4.1. No fault is introduced

In this condition when no fault is created then the results calculated gives the value of THD as 14.44%. The simulated model is same as that of original model Figure 1 and 5.

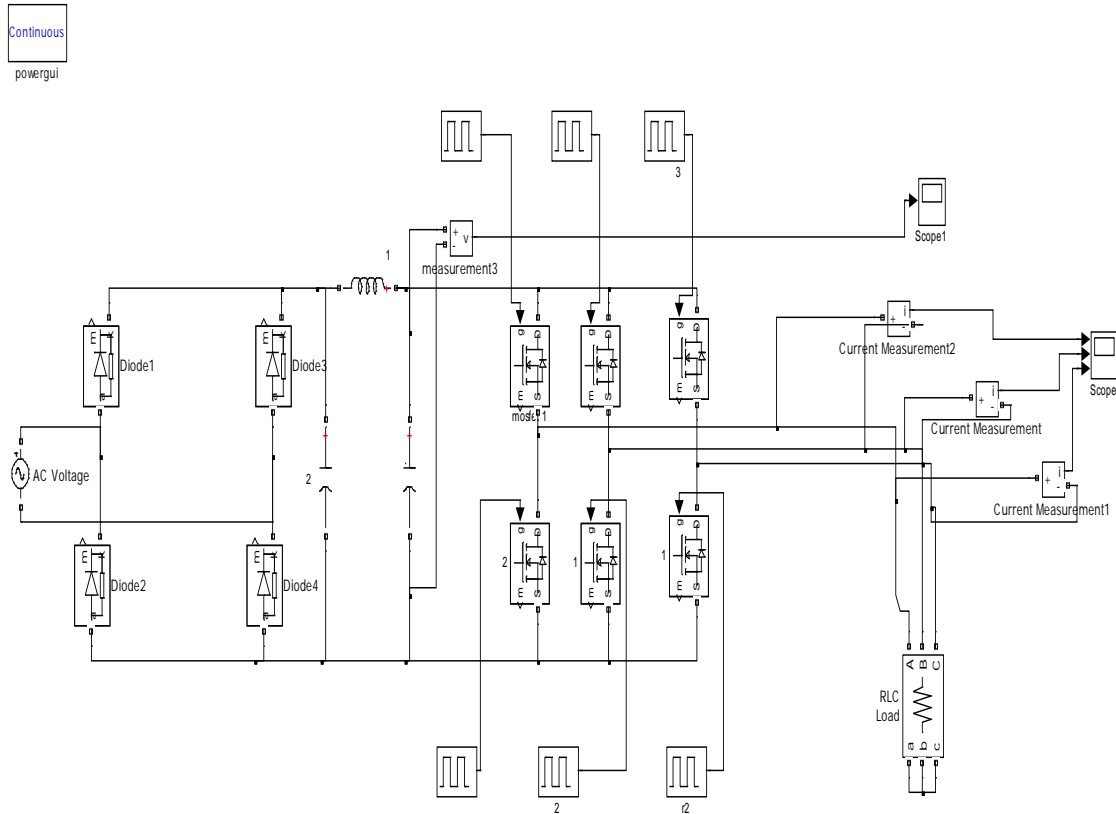

Figure 1. Simulated Model without Fault

Responses of simulation model-The input voltages and output voltage, current of the model is shown in the Figure 2, 3 and 4.

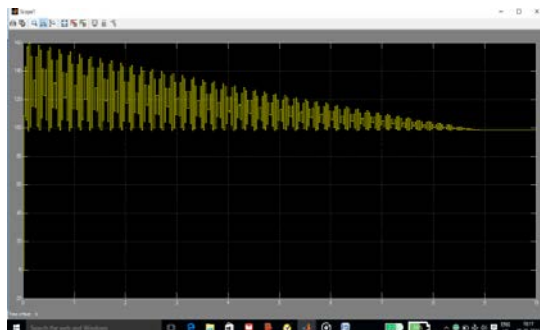

Figure 2. Input Voltage

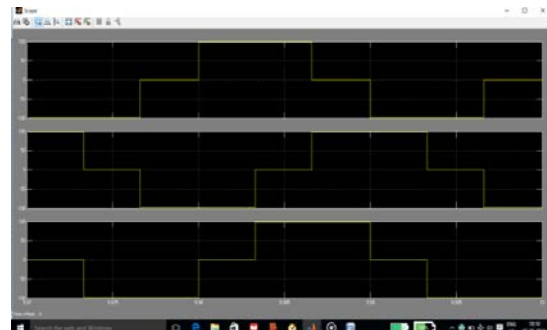

Figure 3. Output Voltage

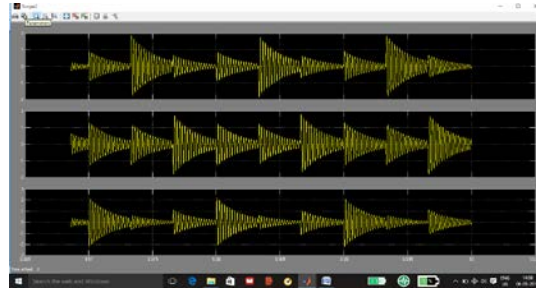

Figure 4. Output Current

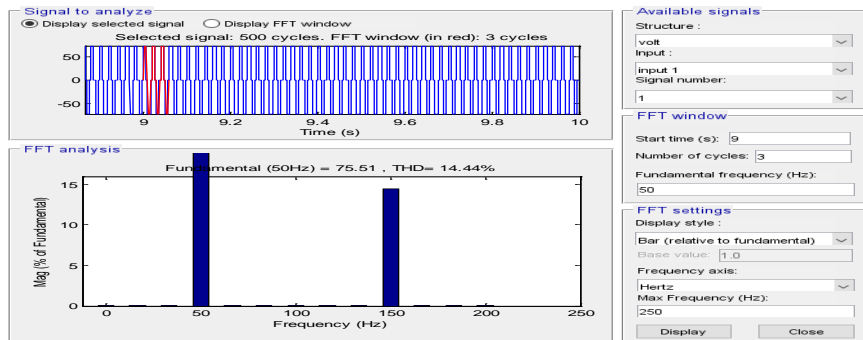

Figure 5. THD without Fault

The value of THD at 50Hz comes out to be 75.57.

4.2. No Gate Pulse at One of the Six MOSFET Gate Terminals

In this case the logic applied in the simulation is to make one of the six mosfet gate pulse to be zero. In fact, here, Mosfet 1 is grounded for the purpose of simulation under the specified condition. The Figure 6 and 7 shows the model and the graph under this situation. The THD comes out to be 19.90% in this situation.

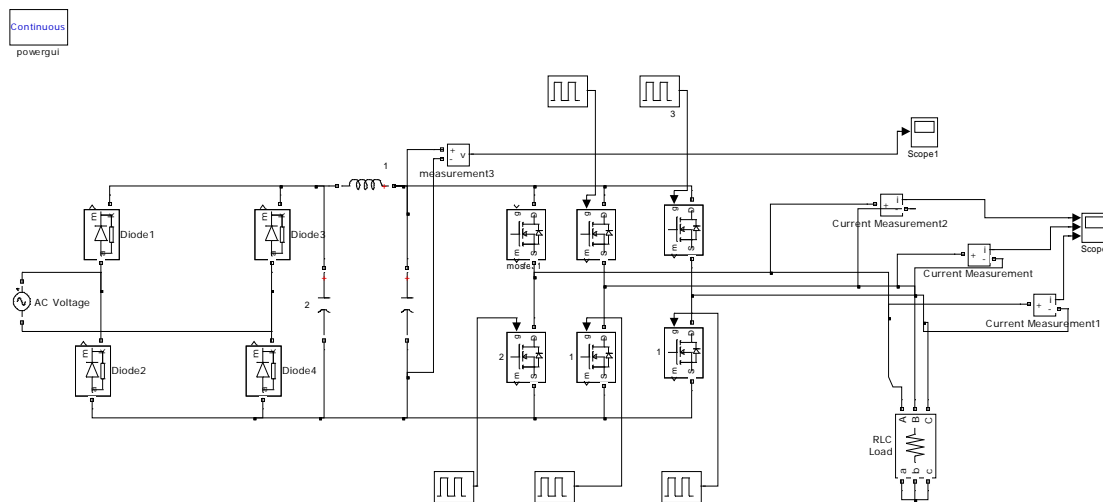

Figure 6. Simulated model with zero-gate pulse at mosfet (1)

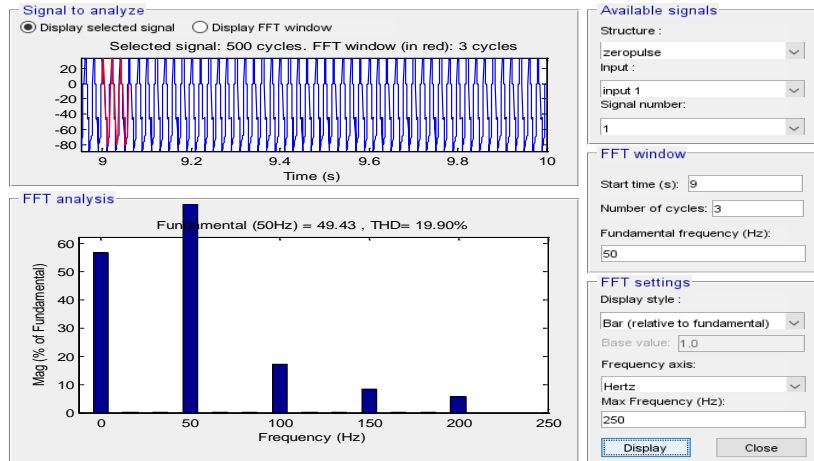

Figure 7. Graph at zero gate pulse

The value of THD at 50 Hz comes out to be 49.43.

4.3. Blowing Off One MOSFET in the VSI Inverter by Introducing A Resistance of 1 kilo ohm

To simulate this condition in the model the upper Mosfet 1 has been replaced by a high resistance. Introduction of the high resistance with one of the six Mosfet is equivalent to the open circuiting of one of the six Mosfet. The THD is recorded which comes out to be 26.99%. The Figure 8 and 9 shows the model and graph of this fault.

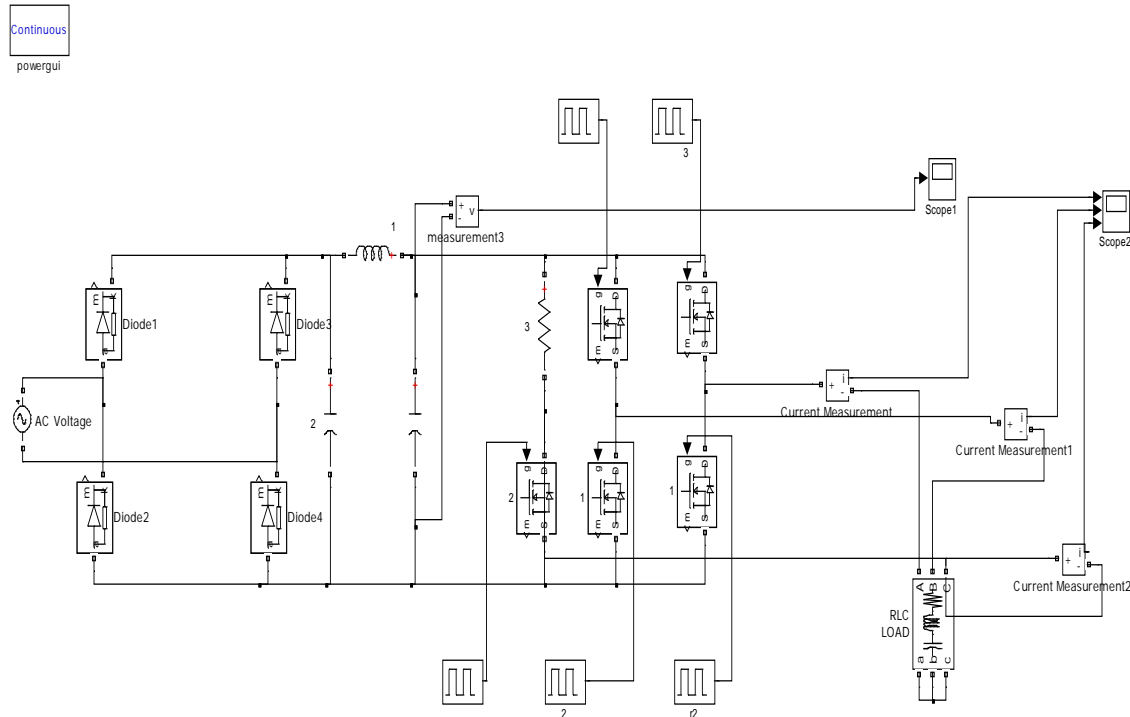

Figure 8. Introduction of High Resistance 1000 ohm

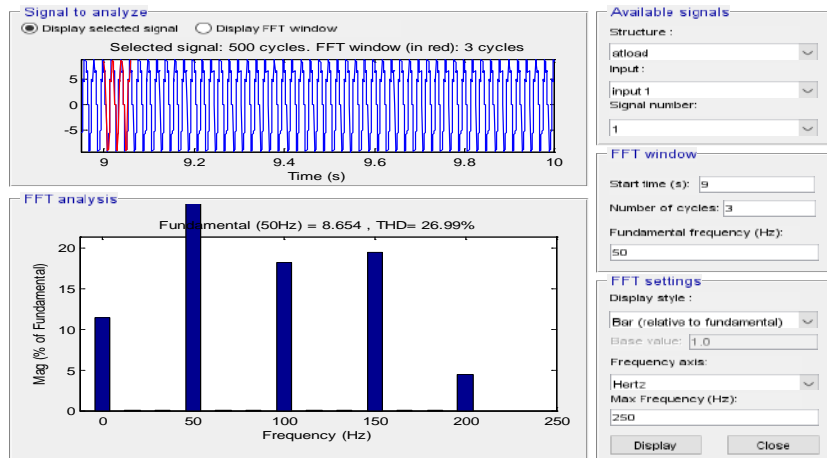

Figure 9. THD when Mosfet Blows off

The value of THD at 50Hz comes out to be 5.654.

4.4. Line to Ground Fault at One of the Motor Terminals

In this type of simulation a ground is introduced in the terminal. Initially the switch is open i.e. terminal is a healthy one i.e. line to ground fault at Phase is created. After The THD is recorded this comes out to be 14.44%. The Figure 10 and 11 shows the model and graph of this fault.

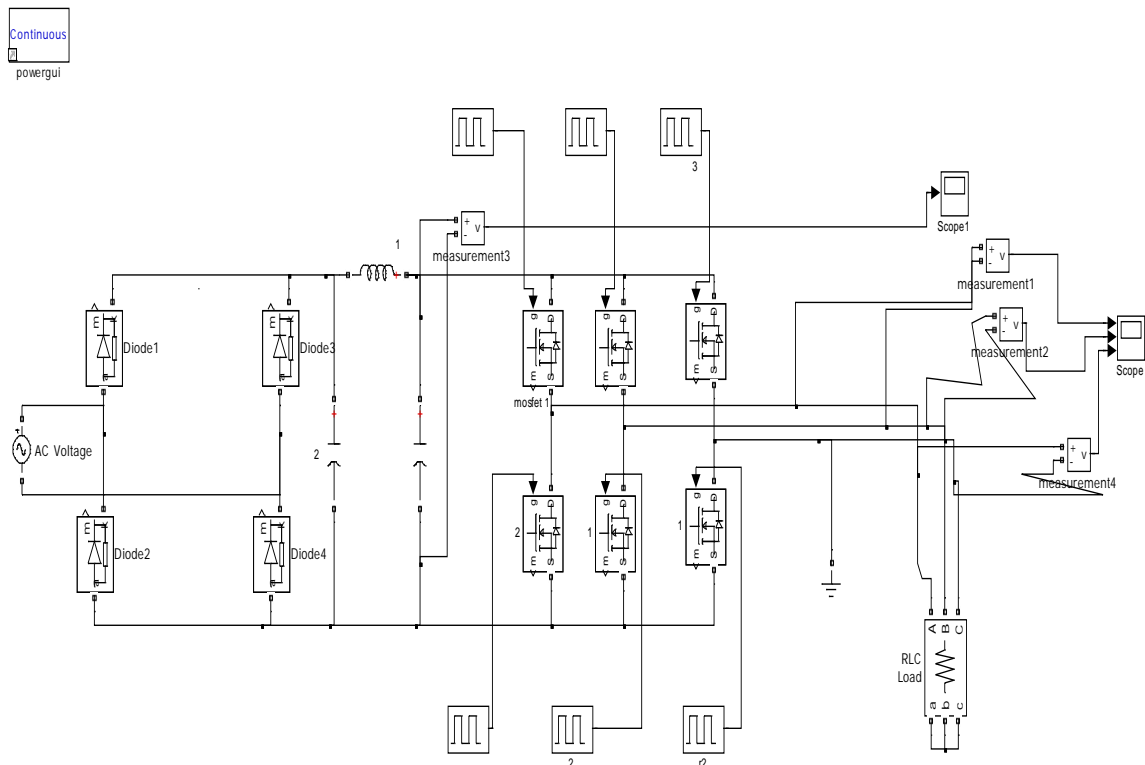

Figure 10. Line to Ground Fault

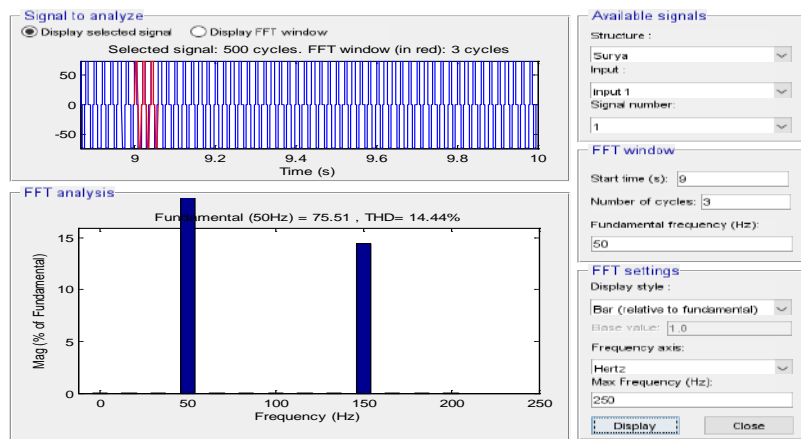
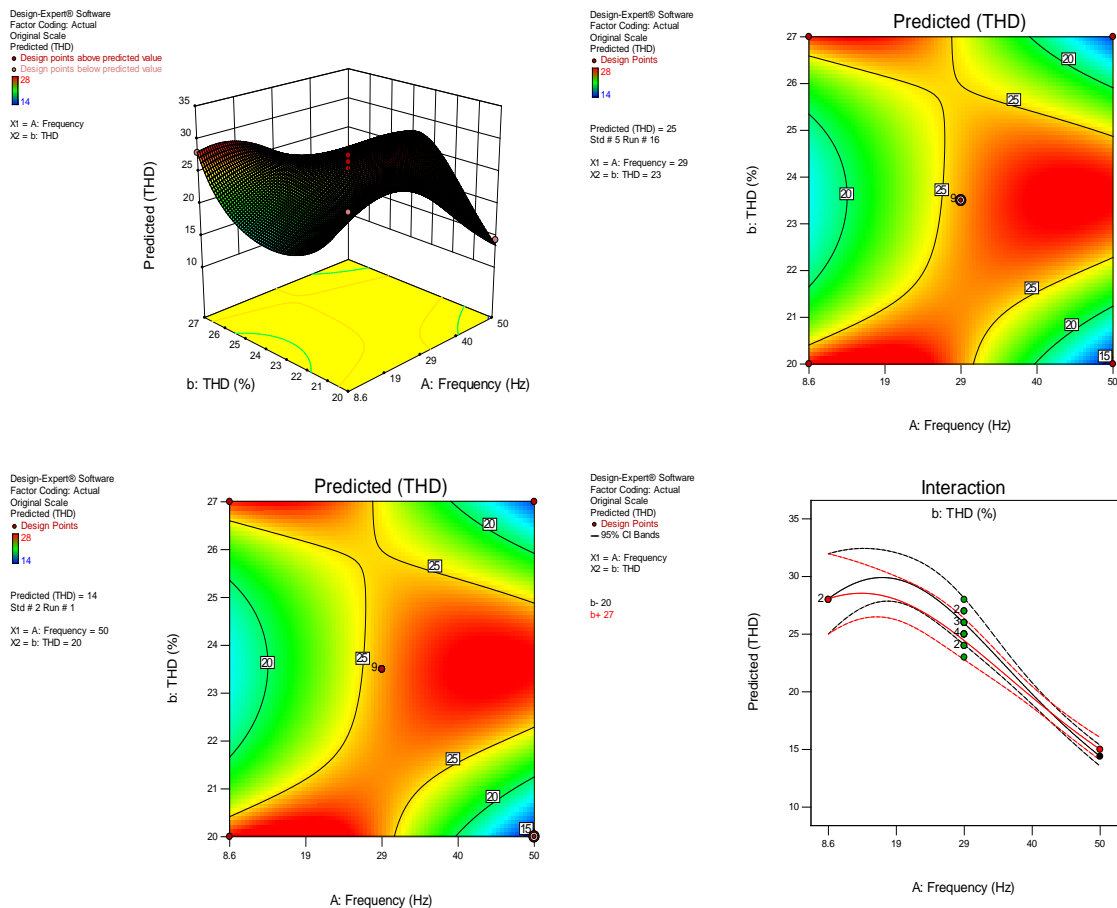

Figure 11. One Terminal Ground

The value of THD at 75.51 comes out to be 75.51.

4. Predicted Response



Above given data prediction gives the result

Table 1 shows the predicted value of THD is (14.44-15) the mosfet bridge gives the best suited results but optimize results varies from (20-27) at 50Hz frequency the THD obtained is 14.44 the reduction method is suitable as ignoring the other frequency constraints.

Table 1. The Predicted Value of THD

Std	Group	Run	Factor 1	Factor 2	Response 1
			A:Frequency Hz	b:THD %	Predicted THD
2	1	1	50	20	14
1	1	2	8.6	20	28
16	2	3	29	23	25
14	2	4	29	23	27
15	2	5	29	23	28
12	3	6	0.046	23	15
13	3	7	58	23	26
17	4	8	29	23	26
19	4	9	29	23	25
18	4	10	29	23	27
10	5	11	29	28	24
11	5	12	29	28	23
3	6	13	8.6	27	28
4	6	14	50	27	15
7	7	15	29	23	26
5	7	16	29	23	25
6	7	17	29	23	24
9	8	18	29	18	25
8	8	19	29	18	26

5. Conclusion

In this study frequency domain analysis and total harmonic distortion is calculated has been used as a tool to discriminate different fault states. The frequency responses and THD for different fault conditions are studied and compared to identify the nature of fault. Frequency responses and THD under four different fault conditions are presented in this paper. Hence, as a study few simple fault conditions are analyzed and aiming to use the same approach for simulating and identifying some more complicated fault situations of modern power system.

The optimization process starts from a large area $a_0b_0c_0d_0$ to a smaller area $a_1b_1c_1d_1$ and up to very small area $a_nb_nc_nd_n$, which are considered as a point solution. In each area must be ensured that the convergent point to be in it. It is stated by the point X is always in the each of the areas. To get a smaller area, the previous area is divided into several areas, and from them is determined the area with the smallest objective value by testing a few points that exist within each area. With the above description, the CFS method is able to work in a variety of objective function of optimization problems, whether differentiable or not, such as step function.

References

- [1] Biswas B, Das S. Current Harmonics Analysis of Inverter-Fed Induction Motor Drive System under Fault Conditions. Hong Kong. 2009; 2: 18-20.
- [2] Namburi, Barton. Time Domain Response of Induction Motors with PWM Supplies. *IEEE Trans. Industry Applications*. 1985; (IA-21): 2. 448-455.
- [3] Sun L, Heming HL. *Analysis on the transient of stator-rotor-hybrid fault in squirrel cage induction motors*. Proc. 2005 ICEMS Eighth International Conference on Electrical Machines and Systems. 2005; (3): 1939 – 1944.

-
- [4] Blodt M, Regnier J. *Fault Indicators for Stator Current Based Detection of Torque Oscillations in Induction Motors at Variable Speed Using Time-Frequency Analysis*. Proc. The 3rd IET International Conference on Power Electronics, Machines and Drives. 2006; 56-60.
 - [5] Pereira, LA, da Silva Gazzana G, and LFAD, Pereira. *Motor current signature analysis and fuzzy logic applied to the diagnosis of short-circuit faults in induction motors*. Proc. 32nd Annual Conference of IEEE Industrial Electronics Society IECON. 2005; 6
 - [6] Azim MI, Mohiuddin SM. Harmonic Analysis of a Single Phase Modulated Inverter. *Indonesian Journal of Electrical Engineering and Computer Science*. 2016; 2(3): 607-616
 - [7] Balamurugan CR, Natarajan SP, Bensraj R. Elucidation of Various PWM techniques for a Modified Multilevel Inverter. *Indonesian Journal of Electrical Engineering and Computer Science*. 2016; (1)3.