

Control Design of Wind Turbine System Using Fuzzy Logic Controller for Middle Voltage Grid

Soedibyo*¹, Feby Agung Pamuji², Mochamad Ashari³

Department of Electrical Engineering, Institut Teknologi Sepuluh Nopember (ITS)
Surabaya (60111), Indonesia

*Corresponding author, e-mail: dibyo_55@yahoo.com¹, febyagungpamuji@gmail.com², ashari@ee.its.ac.id³

Abstract

This paper presents a system wind turbine in order to have continuously electricity supply for 20 kV grid. Output wind turbine controlled by dc-dc boost converter to produce maximum power in order to obtain the MPP (Maximum Power Point). Output of the converter is controlled by fuzzy logic to obtain the MPP (Maximum Power Point) wind turbine, thus the efficiency wind turbine can be increased. The system of wind turbine is connected to 20 kV grid. From the simulation using matlab 2010 can be concluded that the controller can shift power to 75 % maximum power of wind turbine.

Keywords: maximum power point, wind turbine, fuzzy logic controller

Copyright © 2015 Institute of Advanced Engineering and Science. All rights reserved.

1. Introduction

In this century, the increasing of energy demand followed by the increasing cost of fuel. A lot of people are tend to use renewable energy to generate electric energy. Renewable energy is used due to affordable price and produce less pollution (CO₂) in the environment; furthermore less greenhouse effect can be reached [10].

Renewable energy has been explored to meet the load demand. Utilization of renewable energy is able to secure long-term sustainable energy supply, and reduce local and global atmospheric emissions. Wind Turbine (WT) units are become the promising technologies for supplying the load demand in remote and isolated area. However, there are several weakness faced by such resources. One of the weaknesses is the power generated by wind energy is influenced by the weather conditions. The variations of power generated by these sources may not match with the time distribution of demand. In addition, the intermittent power from wind power may result in serious reliability concerns in both design and operation of wind turbines system [11].

Wind turbine (WT) that clean, and abundantly available in nature, are being developed to affordable price and large-scale use. But, highly considered to increase the system efficiency wind turbine as well as to improve the system reliability wind turbine. There are two ways to increase the system efficiency of wind turbine. First, improve the materials to have high conversion efficiency at low cost. Second, to operate wind turbine system optimally. This paper proposed the second way, thus to optimize the system wind turbin (WT) using fuzzy logic controller [10].

2. Research Method

The system consists of wind turbine (WT) connected to 20kV grid, while for wind turbine (WT) have input v (wind speed) and V (actual voltage wind turbine). Fuzzy logic for controlling boost converter to shift the actual voltage to the optimum voltage.

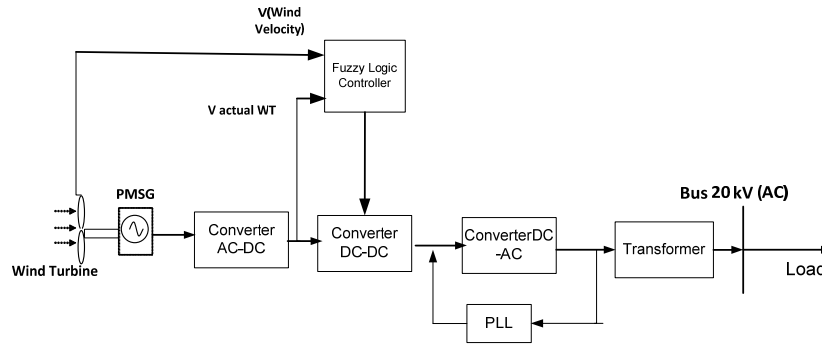

Figure 1. Hybrid system of photovoltaic and wind turbine 20 kV Grid connected

2.1. Wind Turbine

The wind is air moves that caused by unequal heating of the sun to earth surface. Air moves is wind kinetic energy that can be used for various needs, like a generator's prime mover of electricity generation by wind turbine conversion system [10]. The total of wind power that caught by turbine depend on size of rotor blade turbine and wind speed, can be shown in this equation:

$$P_{wt} = \frac{1}{2} \pi R^2 \rho v^3 \quad (1)$$

R is radius of wind turbine, ρ air density and v wind speed. Mechanic power that produced by turbine determined bi wind turbine efficiency, can be shown in this equation:

$$P_m = \frac{1}{2} \eta \pi \rho R^2 v^3 \quad (2)$$

According to Bezt limit, maximum efficiency of wind turbine is 0.57. This value determined by power coefficient and Tip Speed Ratio (TSR) [10]. Power coefficient is mechanical power ratio on turbine with wind power that caught by wind turbine's rotor blade and TSR is speed ratio of wind turbine's rotor blade with wind speed, explain on this equation:

$$C_p = \frac{P_m}{P_{wt}} \quad (3)$$

$$\lambda = \frac{\omega_w R}{v} \quad (4)$$

C_p is power coefficient, λ is Tip Speed Ratio (TSR) and ω_w is angular speed of turbine. Connection between mechanical power with power coefficient and TSR explain on the equation below:

$$P_m = \frac{1}{2} \pi \rho C_p(\lambda, \beta) R^2 v^3 \quad (5)$$

β is angle of wind turbine's rotor blade to wind direction. Mechanical power is power that will be transferred to generator. The value of power coefficient determined by TSR and angle of wind turbine's rotor blade. Connection of TSR, power coefficient, and angle of wind turbine's rotor blade shown in this equation:

$$C_p(\lambda, \beta) = c_1 \left(\frac{c_2}{\lambda_i} - c_3 \beta - c_4 \right) e^{-\frac{c_5}{\lambda_i}} + c_6 \lambda \quad (6)$$

With,

$$\frac{1}{\lambda_i} = \frac{1}{\lambda + 0.08\beta} - \frac{0.035}{\beta^3 + 1} \quad (7)$$

c_1 and c_2 is constant. The value of TSR determined by rotating speed of turbine and wind Speed [10]. The value of power coefficient and TSR varying on a wind speed, depend on turbine rotation. Mechanical torque that used to rotate the generator determined by rotating speed of turbine and mechanical power of turbine, explained in this equation:

$$T_m = 0.5\pi\rho C_p \beta R^2 v^3 \tag{8}$$

Wind turbine that using a gearbox, power and mechanical torque on the generator shaft is:

$$P_m = \omega_m \frac{T_{shaft}}{\eta_{gear}} \tag{9}$$

$$T_m = \frac{T_{shaft}}{\eta_{gear}} \tag{10}$$

$$\omega_m = \omega_w \eta_{gear}$$

T_{shaft} is mechanical torque in low speed shaft, T_m is mechanical torque in generator's shaft, ω_w angular speed of turbine, ω_m is mechanical speed of generator's shaft and η_{gear} gearbox efficiency.

2.2. Wind Turbine Characteristic

Characteristic plot of wind turbine using this following diagram:

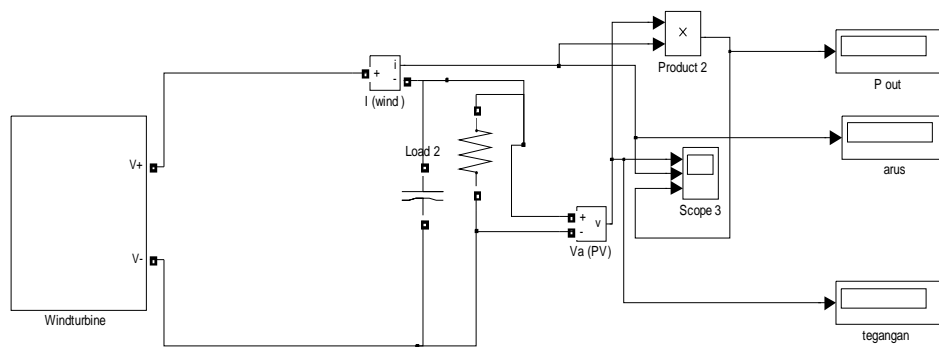

Figure 2. Block Diagram Characteristic Plot of Wind Turbine

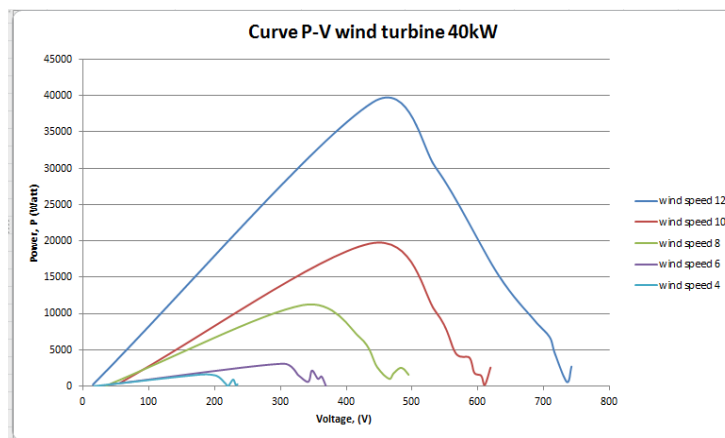

Figure 3. Wind Turbine Characteristic

3. Results and Analysis
3.1. Controller Fuzzy Logic

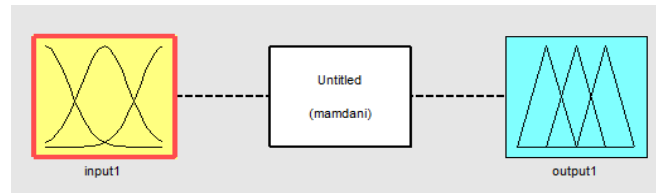

Figure 4. Fuzzy Logic Controller

Fuzzy logic controller is used to control duty cycle so the suitable duty cycle can be obtained for boost converter to get optimal voltage. Control design of MPPT from Wind Turbine can be seen below:

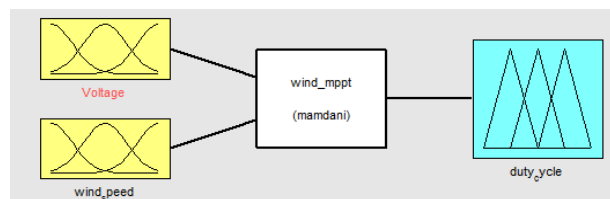

Figure 5. Wind Turbine Fuzzy Logic

Fuzzy logic contains of input and output, for fuzzy input Figure 5 contains of two inputs that are voltage and wind speed. The membership showed below:

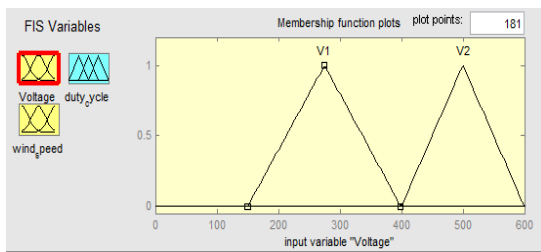

Figure 6. The Voltage of Wind Turbine Membership Function

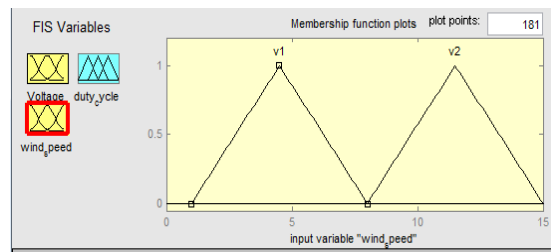

Figure 7. Wind Speed Membership Function

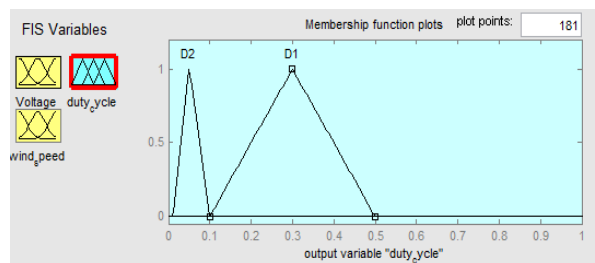

Figure 8. Duty Cycle Membership Function (output fuzzy logic)

- From membership above can be made the rule of fuzzy logic as below:
1. If (Voltage is V1) and (wind_speed is v1) then (duty_cycle is D1) (1)
 2. If (Voltage is V2) and (wind_speed is v2) then (duty_cycle is D2) (1)

5. Simulation Results

5.1. Simulation System Wind Turbine 20 kV Grid Connected

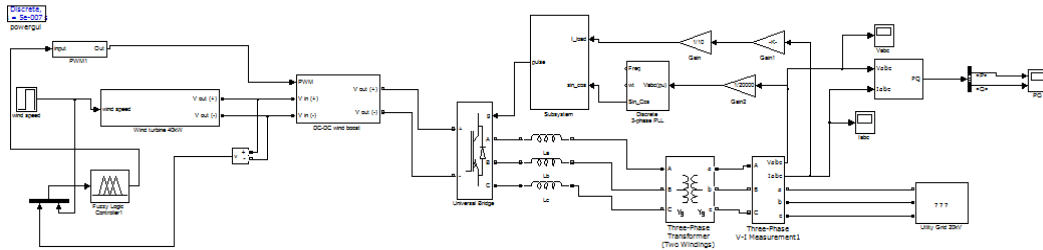

Figure 9. Simulation of System Wind Turbin connected grid 20 kV

The design above composed of wind turbine that controlled using fuzzy logic control to obtain MPP for system. The maximum power condition wind turbine is distributed to 20kV. The simulation results for wind turbine can be seen in Figure 10 below:

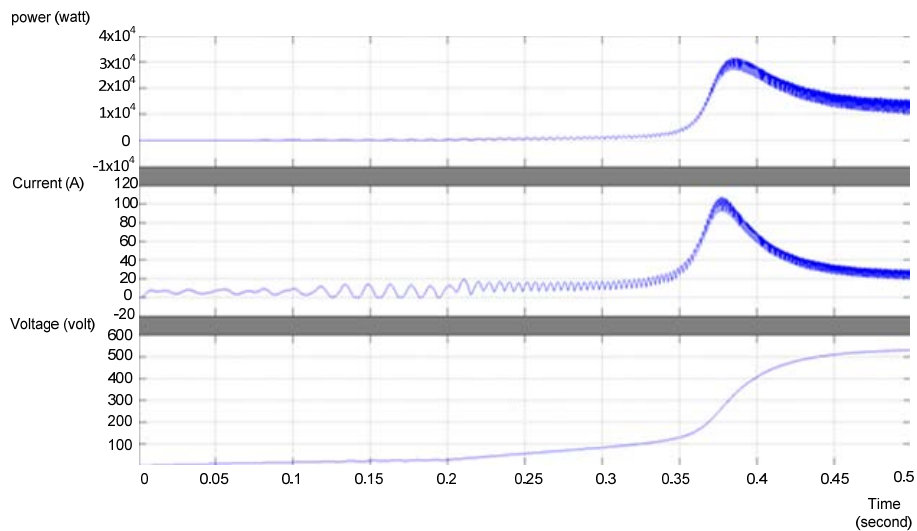

Figure 10. Output from wind turbine generator (power, current, voltage)

From Figure 10, it can be seen that the fuzzy logic controller can control power into maximum, with wind speeds of 8m/s in the second to zero s, wind speed 8m/s to 0.1s, the wind speed of 12m/s to 0.2s, wind speed of 12m/s to 0.3s, wind velocity of 12m/s to 0.4s, and the wind speed of 8m/s to 0.5s.

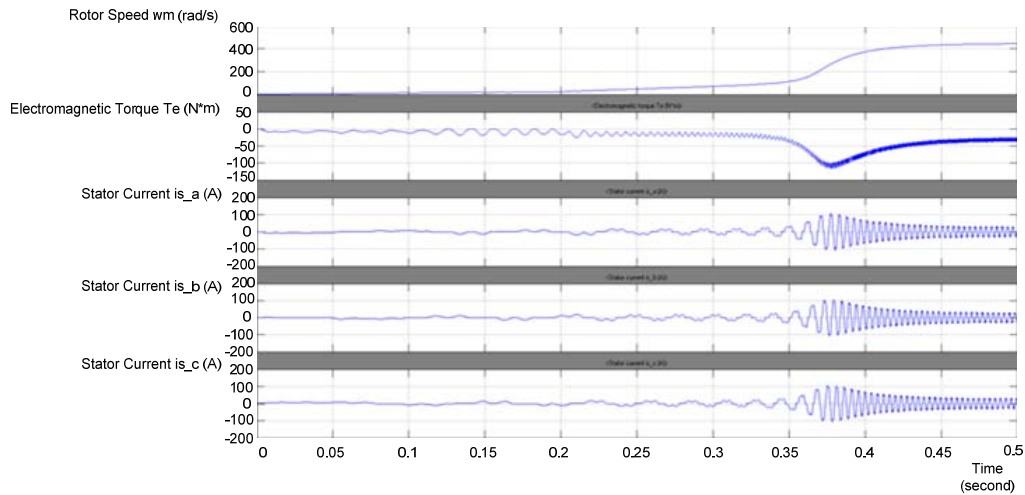

Figure 11. Specification of permanent magnet synchronous generator

From Figure 10 and 11 can be seen that wind turbine not in maximum power. So there is much losses in wind turbine, to shift power to maximum power the wind turbine connected to maximum power point converter.

The simulation results for Output Boost converter (V input, I out, V out) can be seen in Figure 12 below :

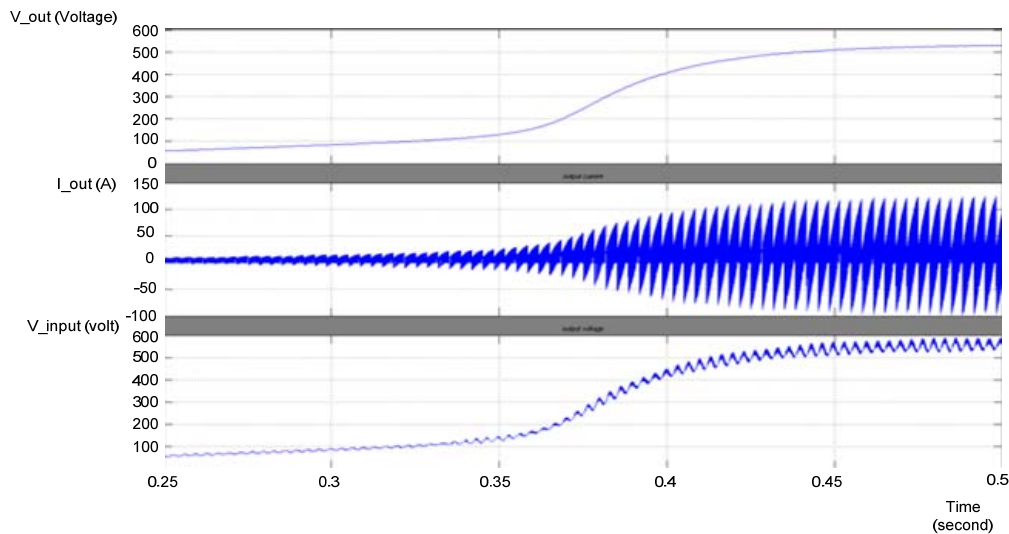

Figure 12. Output Boost converter (V input, I out, V out)

From Figure 12, it can be seen that the fuzzy logic controller can control boost converter in optimum voltage 500 Volt, so the power of wind turbine can be shifted to maximum power.

The simulation results for Power (PQ) output to grid can be seen in Figure 13 below. From Figure 13, it can be seen that the fuzzy logic controller can control power into maximum: P = 7000 watt, Q = 27000 VAR , the maximum power of wind turbine is supplied to 20 kV grid.

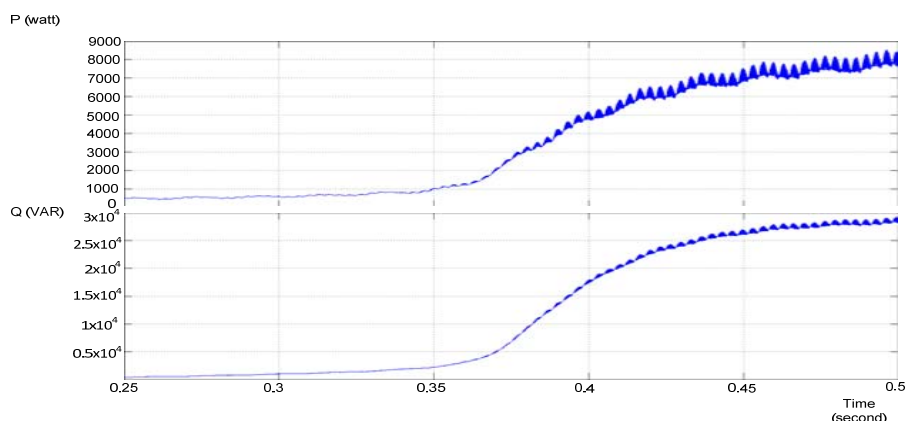

Figure 13. Power (PQ) output to grid

4. Conclusion

Design of a system wind turbine controlled by fuzzy logic can contribute to the power grid 20 kV in accordance with the energy produced in optimum condition. By varying the input wind speed for wind turbines system can generate maximum power. The system of wind turbine can provide power 75% their energy to 20 kV grid.

References

- [1] Hussein Al-Masri, FathiAmoura. Feasibility Study of a Grid Connected Hybrid Wind/PV System. *International Journal of Applied Power Engineering (IJAPE)*. 2013; 2(2): 89~98 ISSN: 2252-8792.
- [2] HUANG Wang-jun, ZENG Zhi-gang, ZHOU Hui-fang, TEN Yuan-jiang, Li Li. Modeling and Experimental Study on Grid-Connected Inverter for Direct Drive Wind Turbine. *TELKOMNIKA*. 2013; 11(4): 2064~2072 e-ISSN: 2087-278X, 2013.
- [3] F Almonacid, C Rus, PJ Perez, L Hontoria. Estimation of The Energy Of PV Generator Using Artificial Neural Network. *Science Direct*. 2009.
- [4] Yusuf Oner, Engin Cetin, Harun Kemal Ozturk, Ahmet Yilanci. Design of Three Degree Of Freedom Spherical Motor For Photovoltaic-Tracking Systems. *Science Direct*. 2009.
- [5] Yulin He, Xinping Chen, *Wind Turbine Generator System*. The Supply Chain In China: Status And Problems. Science Direct. 2009.
- [6] Wissem Zghal, Gueorgui Kantchev, Hedi Kchaou. Optimization And Management Of Energy Produced By A Wind Energizing System, *Science Direct*. 2010.
- [7] YM Chen, SC Hung, CS Cheng, YC Liu. Multi-Input Inverter For Grid-Connected Hybrid PV/Wind Power System. *IEEE*. 2005.
- [8] Chian-song Chiu, T-S Fuzzy. Maximum Power Point Tracking Control of Solar Power Generation Systems.
- [9] Muldi Yuhendri, Mochamad Ashari, Mauridhi Hery Purnomo. *Maximum Output Power Tracking dengan Metode Direct Field Oriented Control Pada Pembangkit Listrik Tenaga Angin Stand Alone*. Seminar Nasional XIV - FTI-ITS. 2009.
- [10] Soediby, Feby Agung Pamuji, Mochamad Ashari. Grid Quality Hybrid Power System Control of Microhydro, Wind Turbine and Fuel Cell Using Fuzzy Logic. *International Review on Modelling and Simulations (I.RE.MO.S)*. 2013; 6(4): 1271 - 1278, Indexed in Scopus, ISSN : 1974 - 9821 / e-ISSN : 1974 - 983X
- [11] Soediby, Heri Suryatomojo, Imam Robandi, Mochamad Ashari. Optimal Design of Hydrogen Based/Wind/Microhydro Using Genetic Algorithm. *TELKOMNIKA Indonesian Journal of Electrical Engineering*. 2012; 10(6): 1309-1318.
- [12] Soediby, Ribka Stephani, Aprilely Ajeng Fitriana, Ratih Mar'atus Sholihah, Primaditya Sulistijono, Suyanto. Power Optimization for Adaptive Wind Turbine: Case Study on Islanded and Grid Connected. *International Review of Electrical Engineering (IREE)*. 2014; 9(4): 835 – 843.