

Utilizing the Optimization Algorithm in Cascaded H-Bridge Multilevel Inverter

M.Suresh Kumar*, Ramani Kannan

K.S.Rangasamy College of Technology/ Anna University,
K.S.R Kalvi Nagar, Tiruchengode, Namakkal-627215/Chennai, INDIA

*Corresponding author, e-mail: sureshmeped13@gmail.com

Abstract

This paper proposed the elimination of undesired harmonic in a Cascaded H-Bridge Multi-Level Inverter by using Selective Harmonic Elimination-Pulse Width Modulation strategy with programmed Particle Swarm Optimization algorithm. In Selective Harmonic Elimination Pulse Width Modulation technique, PSO algorithm is used to determine the non-linear transcendental equation to precise obligatory switching angles for eliminate low order harmonics and reduce the Total Harmonic Distortion from the inverter output voltage waveform while maintaining the required fundamental voltage at the desired value. Computational results are validate that the proposed method does competently eliminate the low order harmonics and also resulted in minimum Total Harmonic Distortion value. The results exposed that the proposed method can achieve efficaciously to the optimal solution more rapidly than other algorithms.

Keywords: multi-level inverter, selective harmonic elimination pulse width modulation, particle swarm optimization, total harmonic distortion

Copyright © 2015 Institute of Advanced Engineering and Science. All rights reserved.

1. Introduction

At the present time, several studies show that the electrical energy demand can raised exponentially and also electrical energy is an immensely prized one in the today market. In the year of 2001 to 2030 energy the statistical review show that the total energy consumption is elevated 16 % from 50 % [1-2]. Mostly this problem arises due to the limited quantity of electrical energy and also raised price of oil progressively. Hence it created a new technical improvement for reduce the total energy consumption and increase the power quality. This new technical scenario shows that the result of continuous development to improve efficiency in all industrial and consumer applications. Therefore it introduced *inverters* in the power conversion system and it is consider as most recognized application in power electronics. Various researches are considered on to growing the quality of output voltage with lower value of Total Harmonic Distortion (THD) [23]. Depend upon this developing demand for high power inverter system, multi-level inverters have been technologically advanced in recent decade from both academic and industry areas.

Multi-level inverter is a well-known power conversion technique to provide the Step output voltage thus it similar as sine wave with minimum value of THD [23-24]. In focus to the application areas of multi-level inverter, it purposeful in the medium and high voltage application like Flexible AC Transmission Systems (FACTS), compressors, mills, conveyors, laminators, UPS systems, broadcasting amplifier and industrial drive. In general multi-level inverter has been categorized into three types: Diode-Clamp Multi-Level Inverter (DCMLI), Flying Capacitor Multi-Level Inverter (FCMLI), and Cascaded H-Bridge Multi-Level Inverter (CHBMLI). The main of advantage of multi-level inverter is essentially compared with the traditional two-level voltage inverter, it provide step output voltage, it produce high power quality, lower harmonic value, better electromagnetic compatibility and lower switching losses [8].

In multi-level inverter, harmonic problem is the significant one with distress the output voltage and augmented level of switching strategy. So many methods like sine-triangle PWM (SPWM), Optimal Minimization of Total Harmonic Distortion (OMTHD) and Selective Harmonic Elimination Pulse Width Modulation (SHE-PWM) are executed for harmonic elimination in multi-level inverter. In SPWM method is very effective for observed the inverter output voltage but this

method have can caused high switching loss because of high switching frequency [9]. In OMTD can only process all harmonics in identical manner to reduce the THD, but it cannot consider the importance of lower order harmonics, higher order harmonics [11-12]. SHE-PWM is a most effective method to eliminate low order harmonics with low switching frequency, improve output power quality and cost of filter is saved for inverters [13]. Some other methods like Newton-Raphson (N-R) method [14], Walsh functions [15] and Block-pulse functions [16] are involved in the harmonic elimination process in multi-level inverter. Though all these methods have some drawbacks to solve this harmonic problem. In N-R method have require initial guess, cannot give optimum solution and divergence problems. Walsh function and Block-pulse function have only determining linear equations, in the event of non-linear transcendental equations are difficult to find well switching result. In recent times, many evolutionary algorithms such as Genetic Algorithms (GA), Bee Algorithms (BA) and Ant Colony Systems (ACS) have been employed in harmonic elimination process of multi-level inverter. Results indication that the proposed method can successfully eliminate certain number of harmonics and the output voltage waveform with lower total harmonic distortion value.

In this paper, the Particle Swarm Optimization (PSO) algorithm can be programmed in SHE-PWM method for estimate the transcendental equation of switching angles to finding the optimal solution. This proposed method can work out the optimal solution of switching angles for eliminate the low order harmonics and minimize the THD value proficiently compared with iterative methods and the resultant theory approach. Simulation results can be shown with conventional design of 7-level CHBMLI to show the validity of proposed method.

2. Configuration of The Cascaded H-Bridge Multi-Level Inverter

A CHBMLI compared with FCMLI and DCMLI, it presented that the merits such as modularity layout, smaller number of components, absence of extra clamping diodes or voltage balancing capacitors and the number of output voltage level can be easily adjusted. In CHBMLI, the period of switches turn ON and OFF process can be done in only once per cycle so it simply solving the switching loss problem. In Figure 1 shown that the CHBMLI have series of H bridge (single-phase full-bridge) inverter units. Each full-inverter H-bridge can produce three different voltage outputs: $+V_{dc}$, 0, and $-V_{dc}$. On the other hand, in Figure 2 has shown the staircase output voltage waveform of CHBMLI. Therefore, the level of CHBMLI is measured in $2S + 1$, where S is the number of dc sources. Consequently in Figure 2 shown that the output voltage waveform of a 7-level CHBMLI with three isolated dc sources ($S = 3$).

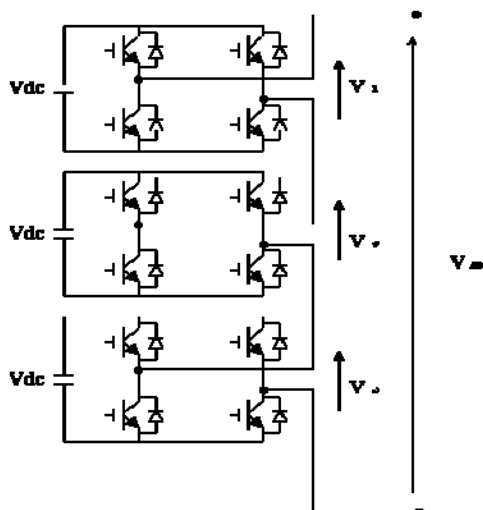

Figure 1. Single Phase Cascaded H-Bridge Multi-Level Inverter

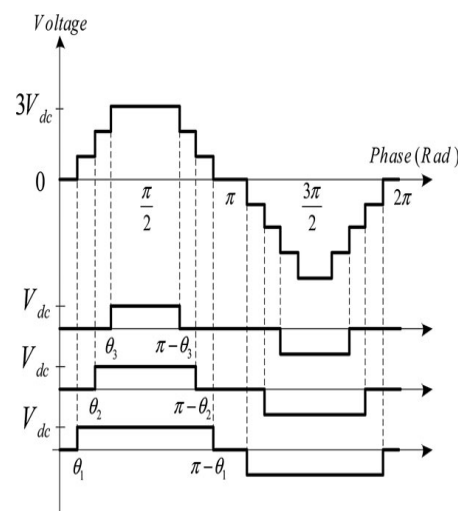

Figure 2. Staircase Output Voltage Waveform of CHBMLI

3. Selective Harmonic Elimination Strategy

In SHE-PWM method used to computing the non-linear transcendental equation to finding sufficient switching angles of 11 level CHBMLI is presented. In CHBMLI produces output phase voltage with required switching angles. To begin with output phase voltage have harmonics is presented. Besides in case of output phase voltage, even harmonics is zero but odd harmonics are critical to evaluate. For that reason, SHE method can be used to calculate the odd harmonics in the phase voltage by using Fourier series expansion. Accordingly Fourier series analysis of output phase voltage is given by

$$V(\omega t) = \sum_{n=1}^{\infty} V_n \cos(n\omega t) + V_n \sin(n\omega t) \quad (1)$$

Considering the amplitude of dc sources and output phase voltage is shown in Figure 2, it would be written as:

$$V(\omega t) = \sum_{n=1}^{\infty} V_n \sin(n\omega t) \quad (2)$$

Where V_n is the amplitude and voltage waveform of n_{th} harmonic component. In SHE-PWM method, switching angles can be assigned within the range of zero and $\pi/2$. Thus V_n improves to define odd and even function is given by $V_n = \frac{4}{n\pi} V_{dc} \sum_{i=1}^s \cos(na_i)$, $n = \text{odd}$ and $V_n = 0$, $n = \text{even}$. The determination of SHE-PWM method in CHBMLI is used to eliminate low order harmonics while other harmonics are removed by using filter. In this paper SHE-PWM method can be performed to eliminate 3rd, 5th, 7th harmonics. In the same way eliminating the low order harmonics by calculate the nonlinear transcendental equation of switching angles are provided as follows,

$$V_n = \frac{4}{\pi} V_{dc}(a_1) + V_{dc}(a_2) + V_{dc}(a_3) \quad (3)$$

$$V_5 = \frac{4}{5\pi} V_{dc}(5a_1) + V_{dc}(5a_2) + V_{dc}(5a_3) \quad (4)$$

$$V_7 = \frac{4}{7\pi} V_{dc}(7a_1) + V_{dc}(7a_2) + V_{dc}(7a_3) \quad (5)$$

In Equation (4) and (5) are assigned to be zero for the purpose of eliminate low order harmonics respectively. By means of Modulation Index (MI) to suggest the fundamental voltage of V_1 is given as:

$$M = \frac{V_1}{sV_{DC}} \quad (6)$$

Substituting Equation (3), (4), (5) into (6) to get nonlinear Equation (7) can be followed:

$$\left. \begin{aligned} M &= \frac{4}{3\pi} \cos(a_1) + \cos(a_2) + \cos(a_3) \\ 0 &= \cos(5a_1) + \cos(5a_2) + \cos(5a_3) \\ 0 &= \cos(7a_1) + \cos(7a_2) + \cos(7a_3) \end{aligned} \right\} \quad (7)$$

At this instant optimal switching angles can be known as a_1 , a_2 , a_3 must be originate depend upon MI. So PSO algorithm can be programmed with SHE method for determining optimal switching value to eliminating lower order harmonics and maintained the fundamental voltage value.

4. Proposed Particle Swarm Optimization Algorithm

PSO algorithm is a new heuristic scheme exposed by Kennedy and Eberhart in 1995 [12]. Essentially PSO algorithm was inspired by the sociological manners of food searching principles such as group of birds and fish manner. PSO is an operative and well-founded optimization algorithm for finding the optimal solution of the nonlinear problems. In PSO, particle

has to be assigned as initial value to determine the probable solution for the non linear problem. In general PSO can find the finest optimal solution from the enter search space.

In PSO ,optimal solution depend upon Gbest and Pbest where Gbest known as global best is denote by $P_g = [p_{g1}, p_{g2}, \dots, p_{gD}]$ and Pbest known as personnel best is denote by $P_i = [p_{i1}, p_{i2}, \dots, p_{iD}]$. On every instance, particles can be updated for finding the realistic solution with respect of position and velocity vectors. In enter search space, position vectors assumed to be $X_i = [x_1, x_2, \dots, x_D]$ and the velocity vector $V_i = [v_1, v_2, \dots, v_D]$ [13]. Every particle can expands the search criteria be influenced by present best value, previous best value and experience of neighboring best value. Using Equation (8) and (9) adjust the particles with respect of velocity and position vectors. Therefore the velocity and position equation is given as:

$$V_{id}^{k+1} = V_{id}^k + c_1 r_1^k (p_{id}^k - x_{id}^k) + c_2 r_2^k (g_{best}^k - x_{id}^k) \quad (8)$$

$$X_{id}^{k+1} = x_{id}^k + V_{id}^{k+1} \quad (9)$$

Where c_1 and c_2 are the constraints of cogitative and social task and r_1 and r_2 are the random values for the initial solution of PSO and its range is within 0 to 1 respectively [15-16].

5. Problem Formulation

In PSO algorithm can be excueted to assume $\theta_i = [\theta_1, \theta_2, \dots, \theta_s]$ be a trial vector establishing the i_{th} particle of the enter swarm to be developed. The constraints of θ_i known the optimal solution for SHE problem and it will be accomplished due to consistent to the various switching angle for the multi-level inverter. And so step-by-step procedure as to be follows to solving the SHE problem with non-equal dc sources.

Step 1: Initialize the population with appropriate locations and range of velocities.

Step 2: Evaluation the fitness of the specific particle in the entire swarm (Pbest).

Step 3: Compute the fitness of individual global particles in the entire swarm (Gbest).

Step 4: Modify Pbest and Gbest Position based on updating velocity constraints

Step 5: Update the particles position at the termination of every iteration.

Step 6: Terminate the iteration process if the condition can get the optimum value

Step 7: Otherwise Go to Step 2.

The above all steps is used to estimate the optimal value, its process can be defined in following flow chart. Hence Figure 3 shown that the PSO flow chart refer to the optimal switching angles for eliminating the lower order harmonic and minimizing the THD valve. In PSO algorithm can apportioned the random particles for the initial constraints for evaluate the best solution depend upon the upgrading of position and velocity parameters. Each position and velocity value can improve the new finest best value in SHE-PWM method.

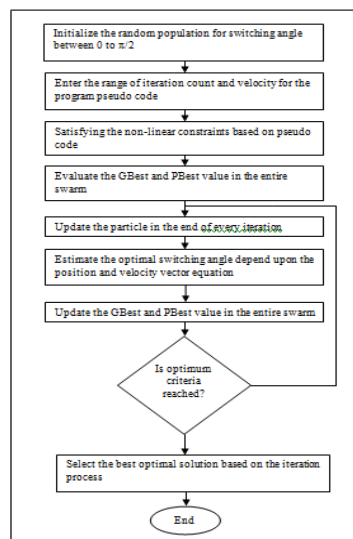

Figure 3. PSO algorithm Flow Chart

6. Analysis of Simulation Results

At the instant proposed 11 level CHBMLI can be simulated by using Matlab/Simulink tool box. Here compare the THD result of conventional 5-level CHBMLI and proposed 11 level CHBMLI programmed PSO algorithm with SHEPWM method using MATLAB/Simulink system. In five levels CHBMLI, carrier wave pulse width modulation method can be used to be pulse generation division. In Figure 4 exposed that the magnitude of output phase voltage of 5 level CHBMLI. In Figure 5 shown that the THD value of 5 level CHBMLI by Fast Fourier Transform analysis. In proposed SHEPWM method, PSO algorithm has been used to determine the optimum solution for estimate the required switching angles. Therefore PSO program can be written in m-file editorial block by using Matlab tool box. Therefore PSO program can insisted with proper initialized the no. of levels,maximum iteration,no.of. switching angels and modulation index. In Table 1 shows the block constraint for the PSO algorithm. The PSO algorithm can be programmed by using if-else statement and for loop condition.

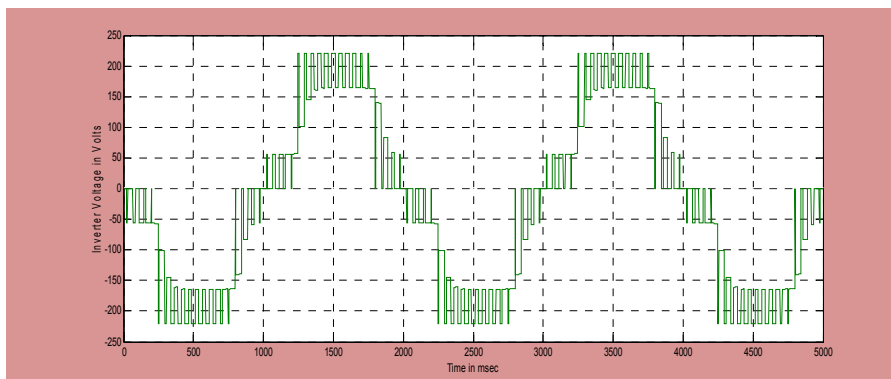

Figure 4. Output Phase Voltage of 5-Level CHBMLI

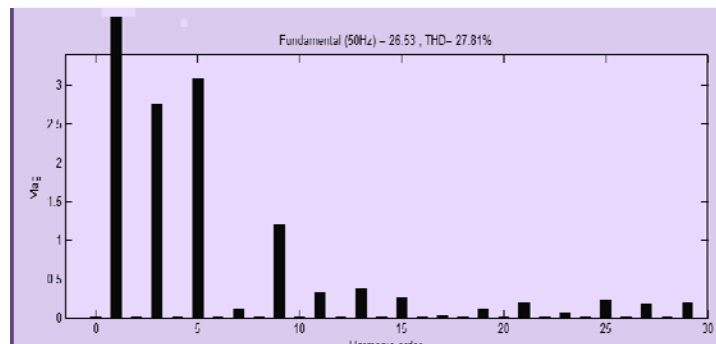

Figure 5. THD result of 5 Level CHBMLI

Table 1. Program Parameter OF PSO Algorithm

S.no	Name of the PSO constraints	Quantity Range
1.	Sources	05
2.	Levels	11
3.	Voltage Value	100 V
4.	Modulation Index	0.1-1
5.	Max Iteration	1000
6.	Intialize Population	300
7.	Voltage Magnitude	0.02
8.	Size of Modulation Index	10
9.	Required Frequency	50 Hz

In the Figure 6 shown that the harmonic orders for the given output phase voltage of 11 level CHBMLI using PSO algorithm. In the Figure 7 shown that the output pulse voltage of 11 level CHBMLI for the given Modulation Index= 0.3 and Load Phase Angle=120 degree.

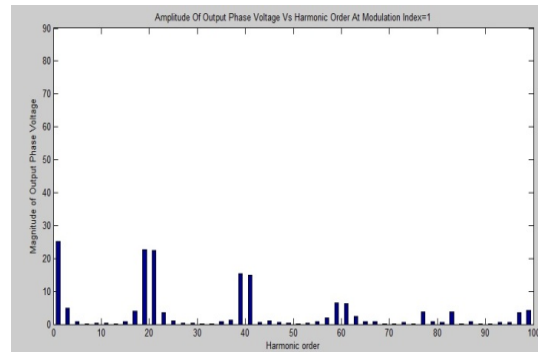

Figure 6. Harmonic Order Vs Magnitude Phase Output Voltage

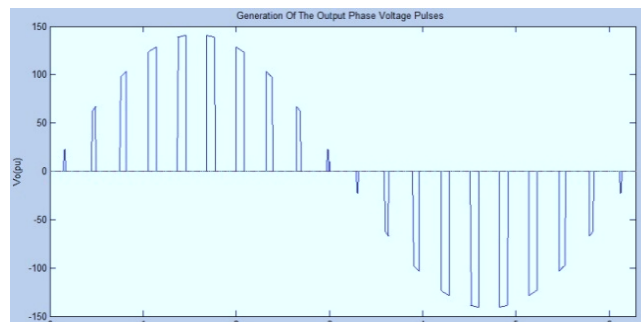

Figure 7. Output Phase Voltage of MI=0.3 at Load Phase Angle=120degree

In the Figure 8 shown that the harmonic order for the given output phase voltage of 11 level CHBMLI using PSO algorithm. In the Figure.9 shown that the output pulse voltage of 11 level CHBMLI for the given Modulation Index= 0.5 and Load Phase Angle=120 degree.

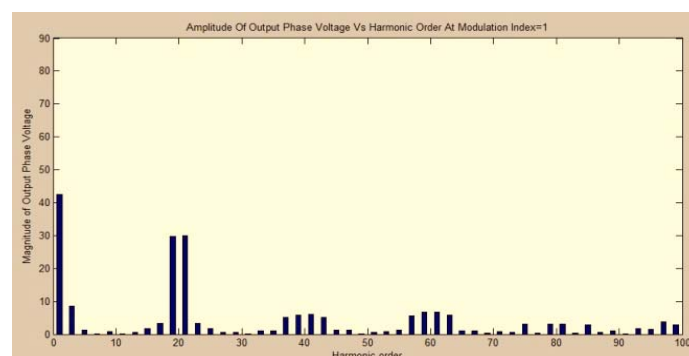

Figure 8. Harmonic Order Vs Magnitude Phase Output Voltage

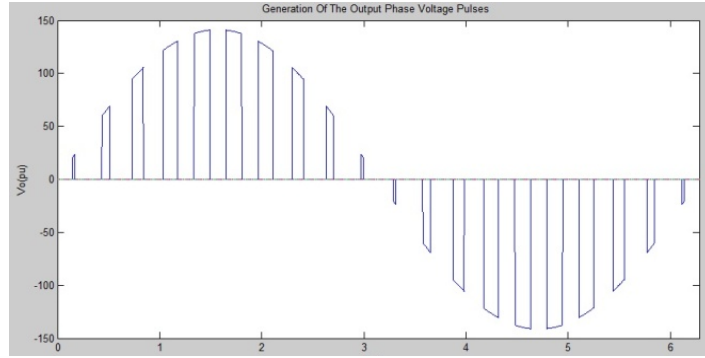

Figure 9. Output Phase Voltage of MI=0.3 at Load Phase Angle=120 degree

Table 2. THD and Output Voltage Value at Various Modulation Index

Modulation Index	RMS output voltage (V _{oRMS})	RMS value of output voltage fundamental component	% V _{oTHD}
0.2	40.8855	16.7162	22.2
0.3	50.2887	25.2896	17.8
0.4	58.1488	33.8128	13.9
0.5	65.1517	42.4474	11.4
0.6	71.1688	50.6500	9.80
0.7	76.7500	58.9139	8.30
0.8	82.1900	67.5671	6.98
0.9	87.4450	76.4662	5.57

In Figure 10 shows the comparison of THD value with various modulation index. In this part has noticed THD value is come in 5 % at modulation index=0.9. In compare with conventional method (THD=27%) THD value is very low in proposed method (THD=5.5%). In proposed method lower order harmonics also eliminated and THD value is minimized.

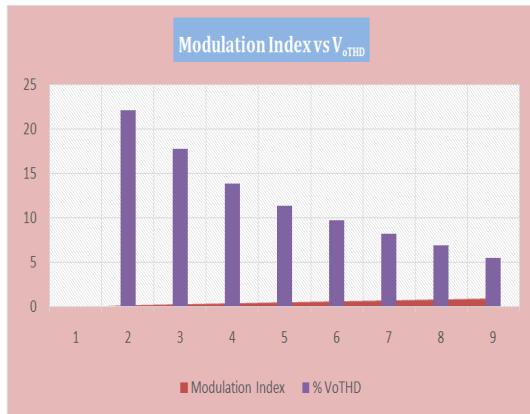

Figure 10. V_{oTHD} vs Modulation Index

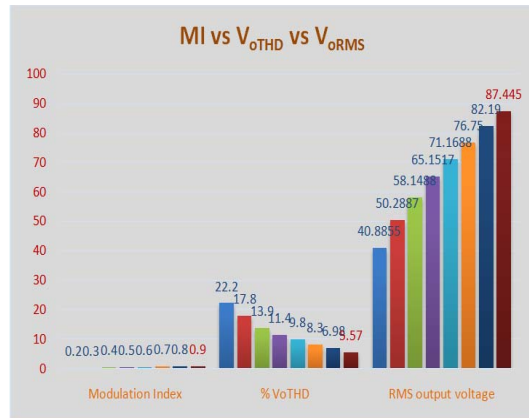

Figure 11. V_{oTHD} vs Modulation Index vs V_{oRMS}

In Figure 11 shown that the comparison between RMS output voltage and THD voltage and MI. It shows that maximum RMS output voltage=87.445V can be attained at V_{oTHD}=5.57% at MI=0.9.

In Figure 12 shown that the comparison between RMS voltage of fundamental component and THD voltage and MI. It shows that maximum RMS voltage of fundamental component=76.462V can be attained at V_{oTHD} =5.57% at MI=0.9

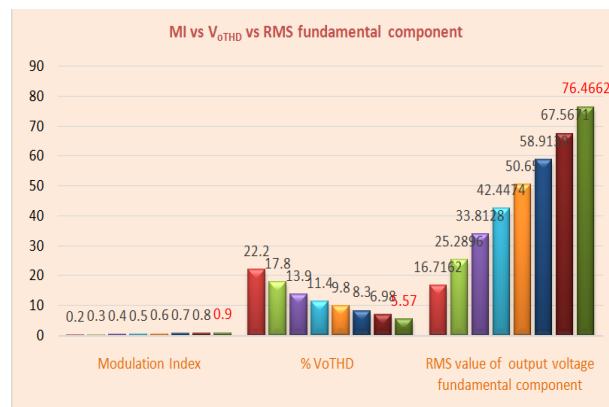

Figure 12. V_{oTHD} vs Modulation Index vs V_{oRMS}

7. Conclusion

In this paper, PSO algorithm can programmed in SHEPWM method to solve the non-linear problem is investigated. The proposed method to solve non-linear transcendental equation to find optimum switching angle for CHBMLI. At the instant, PSO algorithm can be used to eliminate specific number of harmonics, reduce the minimum THD and improves the power quality of the system. These computational results validate that the PSO algorithm can effectively attain the global solution and also contribute better THD results compare with conventional method.

Acknowledgements

The authors want to thank AICTE New Delhi for the support given to this work through the research work and awarded the "Career Award for Young Teachers" *Dr.K.Ramani* (F.No.11.8/AICTE/RIFD/CAYT/POL-I/2013-14).

References

- [1] DG Holmes, TA Lipo. Pulse Width Modulation for Power Converters. Piscataway, NJ: IEEE Press, 2003.
- [2] S Kouro, J Rebolledo, J Rodriguez. Reduced switching-frequency modulation algorithm for high-power multilevel inverters. *IEEE Trans. Industrial Electron.* 54(5): 2894–2901.
- [3] HS Patel, RG Hoft. Generalized harmonic elimination and voltage control in thyristor inverters: Part I— Harmonic elimination. *IEEE Trans. Industrial Application.* 1973; IA-9(3): 310–317.
- [4] HS Patel, RG Hoft. Generalized harmonic elimination and voltage control in thyristor inverters: Part II—Voltage control technique. *IEEE Trans. Industrial Application.* 1974; IA-10(5): 666–673.
- [5] W Fei, X Du, B Wu. A generalized half-wave symmetry SHE-PWM formulation for multilevel voltage inverters. *IEEE Trans. Industrial Electron.* 2010; 57(9): 3030–3038.
- [6] PN Enjeti, PD Ziogas, JF Lindsay. Programmed PWM techniques to eliminate harmonics: A critical evaluation. *IEEE Trans. Industrial Application.* 1990; 26(2): 302–316.
- [7] VG Agelidis, et al. Multiple Sets of Solutions for Harmonic Elimination PWM Bipolar Waveforms: Analysis and Experimental Verification. *IEEE Trans. Power Electronics.* 2006; 21(2): 415–421.
- [8] AI Maswood, et al. A Flexible Way to Generate PWM-SHE Switching Pattern using Genetic Algorithm. *IEEE Applied Power Electronics (APEC) Conf. Proc.*, Anaheim, California, USA. 2001; 2: 1130 – 1134.
- [9] A Sayyah, et al. Optimization of THD and Suppressing Certain Order Harmonics in PWM Inverters using Genetic Algorithms. *Proc. of IEEE International Symposium on Intelligent Control*, Germany. 2006: 874 – 879.

-
- [10] K Sundareswaran, et al. Inverter Harmonic Elimination through a Colony of Continuously Exploring Ants. *IEEE Trans. Industrial Electronics*. 2007; 54(5): 2558-2565.
 - [11] Ayoub Kavousi, et al. Application of the Bee Algorithm for Selective Harmonic Elimination Strategy in Multilevel Inverters. *IEEE Trans, Power Electronics*. 2012; 27(4): 1689-1696.
 - [12] J Kennedy, R Eberhart. Particle Swarm Optimization. (ICNN'95), *Proceedings of IEEE International Conference on Neural Networks*. 1995; IV: 1942-1948.
 - [13] Mohamed Azab. Global maximum power point tracking for partially shaded PV arrays using particle swarm optimization. *International Journal of Renewable Energy Technology*. Inderscience Enterprises Ltd- UK. 2009; 1(2): 211-235.
 - [14] J Hereford, M Siebold. Multi-robot search using a physically-embedded particle swarm optimization. *International Journal of Computational Intelligence Research*. 2008; 4(2):197-209.
 - [15] M Clerc, J Kennedy. The particle swarm: Explosion, stability and convergence in a multi-dimensional complex space. *IEEE Trans. Evolution Computing*. 1998; 2(3): 91-96.
 - [16] K Ramani, A Krishnan SMIEEE. An Estimation of Multilevel Inverter Fed Induction Motor Drive. *International Journal of Reviews in Computing*. E-ISSN: 2076-331X© 2009 IJRIC.
 - [17] K Ramani, A Krishnan. Switching Pattern Selection Scheme Based 11 levels Flying Capacitor Multilevel Inverter fed Induction Motor. *European Journal of Scientific Research*. 2010; 48(1): 51-62.