

A Review Paper on Torque Ripple Reduction in Brushless DC Motor Drives with Different Multilevel Inverter Topology

S. Arunkumar*, S. Thangavel

Department of Power Electronics and Drives, K.S.Rangasamy College of Technology (Autonomous)
K.S.R Kalvi Nagar, Tiruchengode, Namakkal, Tamilnadu, India, Ph./Fax: 04288 274741-44/04288 274860

Corresponding author, e-mail: akumar5989@gmail.com

Abstract

This paper presents the overall review of torque ripple reduction techniques in brushless DC motors (BLDC) and different multilevel inverter topologies suitable for BLDC motor drives. BLDC motors are widely used for household applications due to its features of high reliability, simple frame, high efficiency, fast dynamic response, compact size and low maintenance, etc.. The switches are electronically commutated based on the information of rotor position detection. The position of the rotor is determined with the help of the sensor or sensorless techniques. Hence it is an electronically commutated motor. Because of this commutation, the ripples are generated in the electromagnetic torque and the power factor of AC mains gets affected. So, in order to improve the performance of these motors the ripple in the electromagnetic torque could be reduced and the power factor of the AC mains should be increased. An enormous review of different torque ripple reduction techniques and different multilevel inverter topologies suitable for torque ripple minimization and power quality improvement with different converter topologies are discussed

Keywords: brushless direct current motor (BLDC), multilevel inverter (MLI), back EMF, power factor corrected (PFC), power quality, discontinuous inductor current mode (DICM), bridge less (BL)

Copyright © 2015 Institute of Advanced Engineering and Science. All rights reserved.

1. Introduction

Household appliances like washing machines, room air conditioners, refrigerators, fans, water pumps, vacuum cleaner and freezer are to be expected one of the fastest growing end products in the market over the next few years [1-4]. Conventionally DC motors like shunt and series motors are widely used in these appliances and due to some drawbacks like frequent maintenance and sparking in brushes, consumers are switching over to single phase induction motors. Squirrel cage induction motors are popular due to its rugged construction. But these motors offers poor power factor and efficiency compared to synchronous motor. On the other hand the synchronous motors are affected with speed limitations, noise problem and EMI. These motors operate at constant speed directly from AC mains with low efficiency. Now-a-days consumers are demand for high efficiency, low cost, low acoustic noise and better performance motors for these appliances. The conventional technologies doesn't meet these demands. The use of special electrical machines like brushless DC motors (BLDC), permanent magnet synchronous motors (PMSM) in these appliances are a better choice due to the features of high reliability, high efficiency, low maintenance, high flux density per unit volume, high power density due to absence of field winding and low electromagnetic interference problem [5-6]. The speed adjusting performance and power density of BLDC motor is high compared to PMSM. So BLDC motor is preferable in numerous appliances. The BLDC motors are also used in robotics, medical equipment, precise motion control systems, industrial tools, heating and ventilation systems.

Typically a BLDC motor is an electronically commutated motor. It has three phase distributed winding on the stator, which is made up of stacked steel lamination and permanent magnet on rotor. Depending upon the application requirements the permanent magnets on rotor is either in surface mounted type or buried type. As the name indicates it has no brushes for commutation. The BLDC motor is powered with the help of VSI or CSI. Based on rotor position obtained by rotor position sensors like hall sensors, resolvers or optical encoders, the power

electronic switches are commutated. The shape of the generated back EMF in these motors depends on stator construction. In BLDC motors, the generated back EMF is in trapezoidal shape and in PMSM the generated back EMF is in sinusoidal wave shape. Depending upon the rotor position, the stator windings are energized by rectangular current waveforms which is displaced with 120° [7].

2. State of the Art on Torque Ripple Reduction Techniques

Due to enormous applications of BLDC motors in industries as well as household applications, the performance of these motors are considered to be quite significant. Normally the generated back EMF waveform is not ideal in these motors because of its manufacturing limitation and design consideration of magnetic materials. The back EMF waveform is departed from its original shape. As said earlier, the BLDC motor is an electronically commutated motor, due to commutation of power electronic switches the generated electromagnetic torque containing ripple in its waveform [8]. These torque ripple produces noise which degrades the performance of the motor and complicates the speed-control characteristics especially at low speed. So commutation torque ripple, torque ripple produced by diode freewheeling in an inactive phase are the research hotspot in recent years [9].

The practical BLDC motor setup and trapezoidal back EMF waveforms are shown in Figure 1 and Figure 2. The square wave output of the VSI is fed to the stator winding of the motor. Based upon the rotor position the power electronic switches in the inverter are commutated.

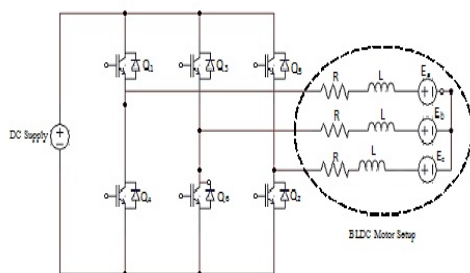

Figure 1. BLDC Motor Setup

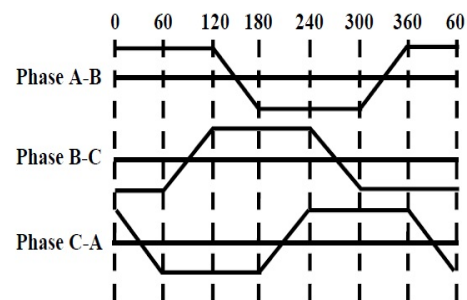

Figure 2. Trapezoidal back EMF waveform

Conventional control techniques energize the stator windings by injecting the similar rectangular phase current command without the knowledge of non-linearity in the back EMF waveform which originates more amount of ripple in the generated electromagnetic torque.

Calson et al. analyzed that the ripple in the generated torque due to phase commutation is related to the energizing phase current and varies with speed. To minimize the torque ripple in BLDC motor two levels of the control scheme is proposed for stator current. The first method employs the position sensor to determine the phase sequence of the rectangular current signals and the moment of current commutation from one phase to another phase and the other method controls the energizing current amplitude by PWM switching of the inverter [10].

Chuang et al. discussed different PWM techniques suitable for commutation torque ripple reduction in BLDC motor drive and proposed that PWM_ON method is the best choice for BLDC motors. But in this discussion the BLDC motor is assumed with ideal back EMF waveform and the non-linearity is not considered [11]. Zhang et al. analyze commutation torque ripple and proposed that the ripple in the electromagnetic torque is minimized by regulating the DC link voltage with the help of buck converter as front end converter of the VSI. With the help of buck converter, the supply voltage is step down and fed to the VSI which results in minimum amount of ripple in the load torque. PWM_ON switching pattern is a better choice for commutation of VSI. The proposed method effectively reduced the torque spikes and dips, but it doesn't considered the bandwidth of the buck converter, so it is suitable at the low speed range only [12].

Chen et al. describes that the buck converter is suitable for low power applications only and it is replaced with Superlift Luo converter topology for DC link voltage regulation which is suitable for high power applications too. But the circuit configuration is more complex compared to buck converter and give better performance under high-speed operation only. To overcome these drawbacks, the Luo converter is replaced with SEPIC converter. But it needs three additional switches and their corresponding inductance, capacitance and diodes, which increase the cost and switching losses [13].

Another major reason for torque ripple in BLDC motor is due to diode freewheeling current in inactive phase. This was analyzed with different modulation techniques for commutation torque ripple and while considering the power dissipation PWM_ON_PWM is the better modulation method [14-15]. While considering the non-linearity in the back EMF waveform, there are only two kinds of resolvents to minimize the commutation torque ripple. One method regulate the armature current of the motor by employing direct torque control [16-19] and the other one is to apply the motor's back EMF as a control parameter to regulate the current. In direct torque control, the back EMF estimation and phase current measurements increase the complexity of the circuit [20-23].

Fang et al. proposed novel automatic current control method for torque ripple minimization in gyro/BLDC motor drive. The non-linearity in the back EMF was considered as a control function for current control and PWM_ON_PWM modulation method is used for commutation which minimizes the torque ripple due to the diode freewheeling in inactive phase [24]. Now-a-days several artificial intelligence based control algorithms are proposed to minimize the torque ripple with non-linearity in the back EMF waveform. In harmonic injection method the ripple in the generated electromagnetic torque due to back EMF harmonics are eliminated. But this method ignores the higher order Fourier series terms used for harmonics calculations because of its complexity and time-consuming calculations also it is more complicated for real time implementation due to its harmonics calculation [25-26].

Torque control in multiphase BLDC motor can be achieved with the help of inequality constraints via Kuhn-Tucker theorem which leads to copper loss and torque ripple reductions. But the inequality constraints requires feedback sensors like high resolution encoders and torque transducer which increase the overall cost of the system [27]. In direct torque and indirect flux control method, the flux and torque estimations are carried out with the help of Clarke and Park transformations. But these transformations are more time consuming because of the difficulty in accuracy of the parameter estimations [28-29].

3. Review on Different Multilevel Inverter Topology

Normally the BLDC motor is powered by either VSI or CSI. The two level inverter produces square wave output with harmonic distortions in its waveform, which results in total harmonic distortions (THD) in the output. Due to these effects the ripples are created in the output electromagnetic torque and distortion in the trapezoidal back EMF waveform. Conventionally controlled rectifier with large value of inductor in series act as a current source which increase the overall cost of the system as well as the system looks so bulky.

When the level of the output voltage is increased, the harmonic content gets reduced. The waveform is in staircase shape. The distortions in the stator current as well as the electromagnetic torque get reduced with high levels. These causes the generated electromagnetic torque contains minimum ripple in its waveform. Also the two level inverter is not suitable for high power applications but the multilevel inverter is suitable for high power applications by increasing the level of the output voltage.

A comparative analysis between two level inverter and multilevel inverter with different modulation techniques are carried out and the results are depicted as graphical view in Figure 3(a)-3(d). From the graphical representation, it was clear that the multilevel inverter is the best choice for motors. The performance and efficiency of the motor is increased with the help of increasing the output levels of the inverter. Even though increasing the number of levels results in more number of switches and the control will be more complicated, which is often a limitation for the use of the multilevel inverter, better quality of load torque is considered to be the outcome of the MLI fed BLDC motor.

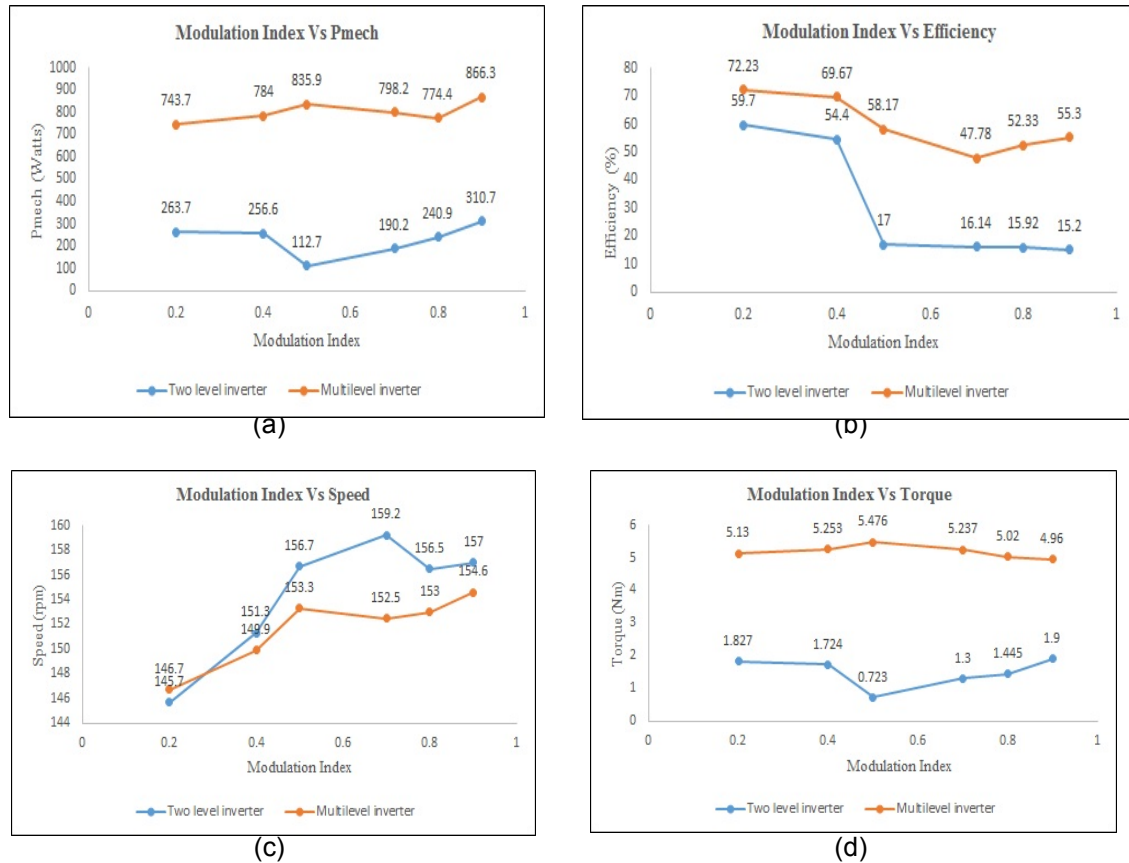

Figure 3. Comparative analysis of (a) P_{mech} , (b) efficiency, (c) Speed and (d) torque of the two level and multilevel inverter

The multilevel inverter is grouped into three types of configuration namely, Diode clamped multilevel inverter, flying capacitor multilevel inverter and cascaded H-bridge multilevel inverter.

3.1. Diode Clamped Multilevel Inverter

The single phase five level diode clamped multilevel inverter is shown in Figure 4. The voltage stress on the power device is limited with the help of the diodes is the major concept of these inverters. The three phase inverter output voltage shares common DC bus voltage and it is divided for five level with the help of the capacitors. The voltage across each capacitor and switches is V_{dc} which is same as the supply voltage. So there is no possible for high voltage stress across devices. Each leg as consist of switches, clamping diodes, freewheeling diodes and also capacitors. It is also named as neutral clamped inverter. The major drawback of these inverter is DC link voltage unbalancing. The components required for n-level inverter is:

- Voltage sources: $(n-1)$
- Switching devices: $2(n-1)$
- Diodes: $(n-1)*(n-2)$

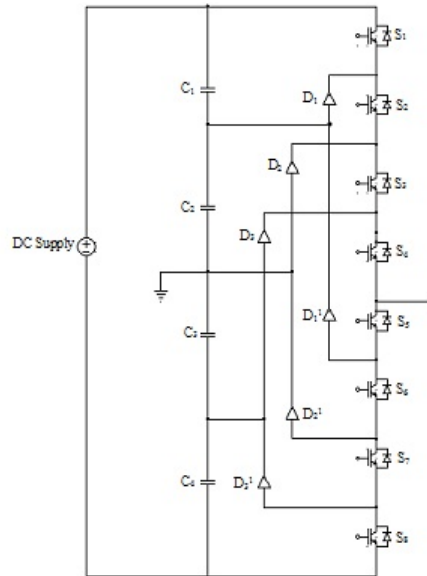

Figure 4. Diode Clamped Multilevel Inverter

The switching pattern for five level diode clamped multilevel inverter is shown in Table 1.

Table 1. Switching States for 5-level DCMLI

Voltage	Switching States							
	S ₁	S ₂	S ₃	S ₄	S ₅	S ₆	S ₇	S ₈
V _{dc} /2	1	1	1	1	0	0	0	0
V _{dc} /4	0	1	1	1	1	0	0	0
0	0	0	1	1	1	1	0	0
-V _{dc} /4	0	0	0	1	1	1	1	0
-V _{dc} /2	0	0	0	0	1	1	1	1

In the look up table '1' represents that the corresponding switch is in ON position and '0' represents that the switch is in OFF condition. At an instant four switches are in ON position. The upper arm switches are commutated at maximum positive voltage and the lower arm switches are commutated at negative maximum value. At fundamental frequencies, it is more efficiency.

3.2. Flying Capacitor Multilevel Inverter

The circuit configuration of this inverter is similar to the neutral point clamped converter but it requires high numbers of auxiliary capacitors which is shown in Figure 5. It doesn't requires any clamping diodes. As the name indicates, the common DC bus voltage is divided into five level with the help of flying capacitors. The main advantages of this converter is it doesn't require any filters for high level and active and reactive power flow is possible in both directions. But the control of the system is complicated when the output level is increased. The components required for n-level inverter is:

- Main capacitors : (n-1)
- Auxiliary capacitor : (n-1)*(n-2)/2

The look up table for these inverters are similar to that of neutral point clamped multilevel inverter. The only difference is absence of the clamping diodes.

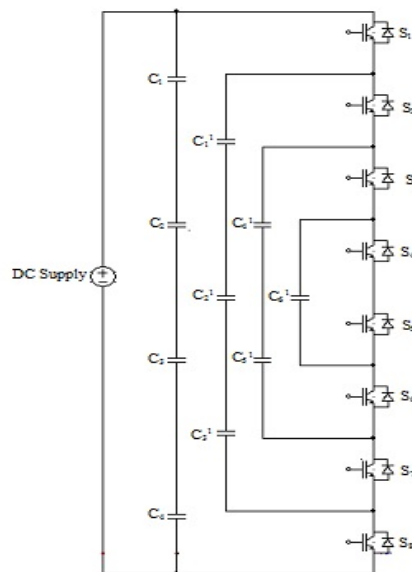

Figure 5. Flying Capacitor Multilevel Inverter

3.3. Cascaded H-Bridge Multilevel Inverter

The cascaded H-bridge multilevel inverters are built with series connection of H-bridge inverter with separate DC sources. As the name indicates H-bridge inverters are cascaded with each other to produce staircase waveform. When the level gets increased the number of inverters cascaded is also increased. It doesn't need any clamping diodes and flying capacitors. For three phase configuration, the cascaded converters can be linked either in star connection or delta connection. Compare to other topologies, it uses less components which results in minimum amount of switching losses. The control of these inverter is also simple. But it requires isolated DC sources for the power conversion, which limits its use. For n-level inverter the number of switching device required is $2(n-1)$ per leg [30]. The circuit configuration of single phase five level inverter and its output voltage waveform is shown in Figure 6 and Figure 7 respectively. The switching states for five level inverter is shown in Table 2.

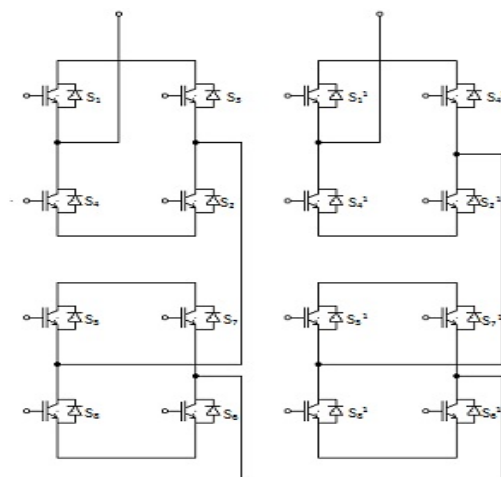

Figure 6. Cascaded H-bridge Multilevel Inverter

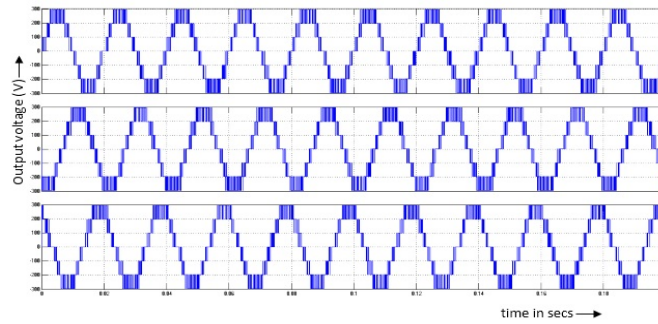

Figure 7. Five level output voltage waveform

Table 2. Switching States for 5-level CHBMLI

Switches Turn ON	Voltage Level
S1, S2	+Vdc
S1,S2,S5, S6	+2Vdc
S4,D2,S8,D6	0
S3,S4	-Vdc
S3,S4,S7,S8	-2Vdc

In the look up table, diode freewheeling occurs at the zero voltage level. At Vdc only two switches are in conducting mode. When the level gets increased, the number of switches conducted is also increased. Two switches from upper cell and the two switches from lower cell are conducted. When the BLDC motor is powered with two level inverter, the generated torque contains significant amount of ripple which is shown in Figure 8.

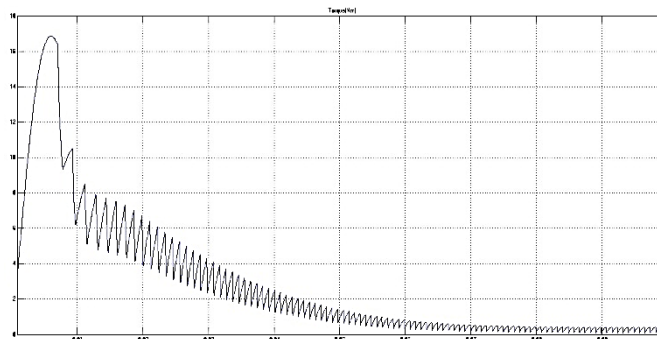

Figure 8 Electromagnetic Torque Waveform (Two level Inverter)

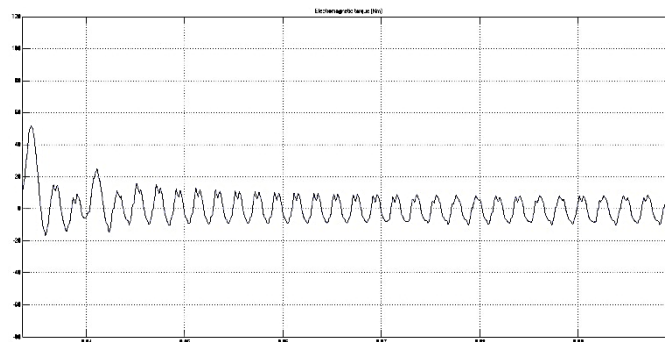

Figure. 9 Electromagnetic Torque Waveform (Multilevel Inverter)

When the BLDC motor is powered with multilevel inverter, the generated electromagnetic torque contains minimum amount of ripple in its waveform which is shown in Figure 9.

Table 3. Comparative Analysis of Different Multilevel Inverter Topology

Terms	Diode Clamped	Flying Capacitor	Cascaded H-Bridge
Source	(n-1)	(n-1)	2(n-1)
Clamping diodes	(n-1)*(n-2)	-	-
Capacitors	(n-1)	(n-1)*(n-2)/2	-
Component Count	High	High	Minimum
Switching Loss	Moderate	Moderate	High
Voltage Stress	Moderate	Moderate	Minimum

Among these three topologies single source, multi DC link cascaded H-bridge multilevel inverter is the best choice for torque ripple minimization in the BLDC motor drive.

4. Power Factor Correction

The power quality has become the most significant factor to be considered at the point of BLDC motors. The international standards such as International Electrotechnical Commission (IEC) 61000-3-2, suggested such that the harmonics in the supply current should be within the acceptable limit. For class-A equipment (< 600 W, 16 A per phase) which includes household appliances, the IEC 61000-3-2 limits that the THD of the supply current should be below 19% [31]. Conventionally diode bridge rectifier (DBR) with large value of DC link capacitor is used as a front-end rectifier in VSI fed BLDC motors. This circuit results in highly distorted supply current with THD of 65% and a poor power factor of 0.8 which is not accepted by International Power Quality (PQ) standards such as IEC-61000-3-2 [32]. Hence a power factor corrected (PFC) frontend rectifiers are necessary to improve the power factor in order to improve the power quality (PQ) at the AC mains.

Two stage PFC converters are in practice in which one PFC converter concentrated on improving the power quality (PQ) at AC mains which is typically a boost converter and another one is for voltage control, which depends upon the choice of application. A single stage PFC converters has gained much more care because the PFC operation and the DC-link voltage control can be achieved in a single stage [33-34].

In the conventional PFC scheme the speed control can be achieved with the help of pulsewidth-modulated voltage source inverter (PWM-VSI) with constant dc link voltage. This results higher switching losses in the VSI which is the square function of switching frequency. The speed of the BLDC motor is directly proportional to the DC link voltage. So the speed control can be attained by a variable DC link voltage of VSI with fundamental frequency switching (electronic commutation). This provides minimum switching losses.

Singh and Singh [35] have proposed the concept of buck-boost converter fed BLDC motor and the speed control can be achieved by PWM_VSI with constant DC link voltage, which offers high switching losses. The buck-boost converter is replaced with single-ended primary-inductance converter (SEPIC) based VSI fed BLDC motor drive has been proposed by Gopalarathnam and Taliyat. But it requires more number of current and voltage sensors which restricts its applicability to low power applications [36].

The switching losses due to fundamental frequency switching of VSI for electronic commutation of BLDC motor can be minimized with the help of Cuk converter fed BLDC motor drive with a variable DC link voltage has been proposed by Singh and Singh [32]. But it requires three voltage control sensors for PFC operation which is not cost effective and suitable for high power applications only.

For further improvement in the efficiency and performance of the BLDC motor the front-end bridge rectifiers are replaced with bridgeless (BL) topologies. The BL topology provides less conduction losses across the switches. Jang and Jovanovic [37] and Huber et al. [38] have

proposed the BL buck and boost converter for PFC operation. But it limits the operating range of the dc link voltage control due to separate step up and step down operation of the converter. Also large inrush current at the time of starting is major drawback of these converters.

Abbas A. Fordoun et al. analyze the Cuk derived converters for PFC operation in BLDC motors. They proposed three types of cuk derived converters. The Cuk converter has characterized as natural protection against inrush current and overload current, lower ripple content in the current and low electromagnetic interference (EMI) [39]. The equivalent circuit of Cuk derived converters is shown in Figure 10(a)-(c).

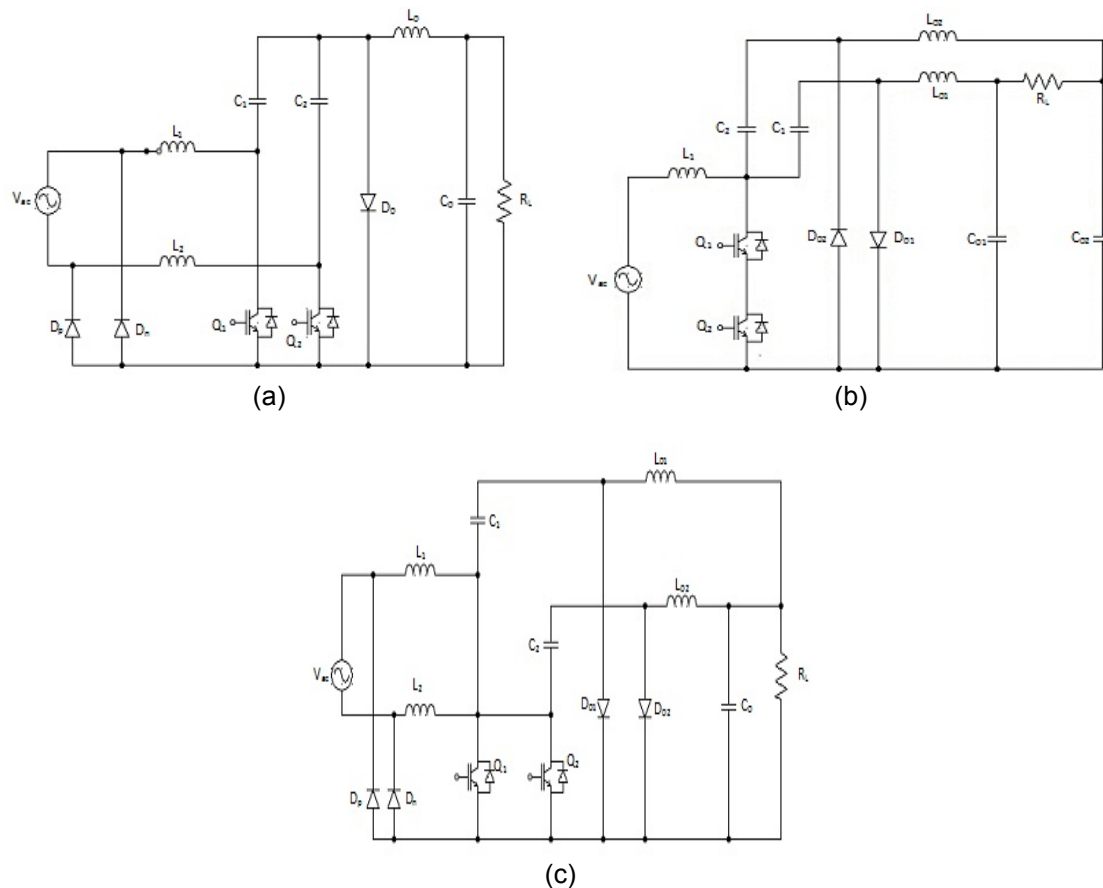

Figure 10. Equivalent circuits for (a) Type I. (b) Type II and (c) Type III Cuk derived PFC Converters

Among the different BL converter topologies, the bridgeless buck-boost rectifier has less component count compared to cuk derived converters. To achieve inherent power factor correction at AC mains, the rectifier is functioned in a discontinuous inductor current mode (DICM). This rectifier offers low switching losses in VSI, because the VSI operates in low frequency for electronic commutation in BLDC motor [40]. The equivalent circuit for the BL buck-boost converter is shown in Figure 11. The comparative analysis between the different PFC converter topologies is tabulated in Table 4.

Hence the BL buck-boost PFC converter is a best choice for improving the power factor at the AC mains in order to obtain the best power quality. Compared to other BL topologies the buck-boost converter have a minimum number of components. So the losses associated with the switches and stress on switches gets reduced.

Table 4. Comparative Analysis of BL Converter Topologies

Configuration	No. of Devices					Suitability
	S_w	D	L	C	TOTAL	
BL-BUCK	2	4	2	2	10	NO
BL-BOOST	2	2	1	1	6	NO
BL-CUK T-1	2	3	3	3	11	YES
BL-CUK T-2	2	2	3	4	11	YES
BL-CUK T-3	2	4	4	3	13	YES
BL-BUCK-BOOST	2	4	2	1	9	YES

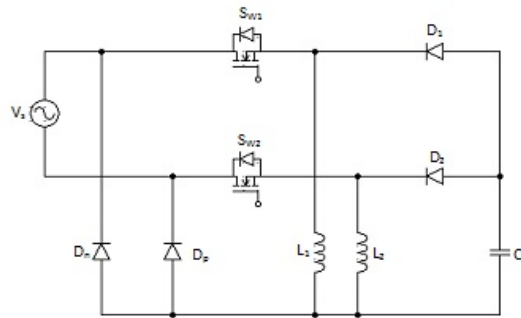

Figure 11. Equivalent circuit of bridgeless buck-boost converter

5. Conclusion

An exhaustive overview of torque ripple minimization techniques with different multilevel inverter topologies and power quality improvement in the brushless dc motors (BLDC) has been presented in this paper. Among different torque minimization techniques, the cascaded H-bridge multilevel inverter gives better performance in the efficiency as well as smoother distortion less stator current. The harmonics in the stator current are effectively reduced which minimize the THD. Also different PFC converters are analyzed for power quality improvement at AC mains. From this analysis the BL buck-boost converter provides reduced switching losses and stresses across the switches. The BLDC motor has inherent household applications and the performance of these motors have been improved by BL buck boost converter as front-end rectifier and cascaded H-bridge multilevel inverter fed BLDC motor drive.

References

- [1] Dai M, Keyhani A, Sebastian T. Torque ripple analysis of a PM brushless DC motor using finite element method. *IEEE Trans. Energy Convers.* 2004; 19(1): 40–45.
- [2] Wang HB, Liu HP. A novel sensorless control method for brushless DC motor. *IET Electr. Power Appl.* 2009; 3(3): 240–246.
- [3] Gan WC, Qiu L. Torque and velocity ripple elimination of AC permanent magnet motor control systems using the internal model principle. *IEEE/ASME Trans. Mechatron.* 2004; 9(2): 436–447.
- [4] Tabarraee K, Iyer J, Atighechi H, Jatskevich J. Dynamic average-value modeling of 120° VSI-commutated brushless DC motors with trapezoidal back EMF. *IEEE Trans. Energy Convers.* 2012; 27(2): 296–307.
- [5] Kim TH and Ehsani M. Sensorless control of the BLDC motors from near-zero to high speeds. *IEEE Trans. Power Electron.* 2004; 19(6): 1635–1645.
- [6] Ozturk SB, Alexander WC, Toliyat HA. Direct torque control of four-switch brushless DC motor with non-sinusoidal back EMF. *IEEE Trans. Power Electron.* 2010; 25(2): 263–271.
- [7] Bhim Singh, Sanjeev Singh. State of the Art on Permanent Magnet Brushless DC Motor Drives. *Journal of Power Electronics.* 2009; 9(1): 1-17.
- [8] Haifeng Lu, Lei Zhang, Wenlong Qu. A New Torque Control Method for Torque Ripple Minimization of BLDC Motors with Un-Ideal Back EMF. *IEEE Trans. Power Electron.* 2008; 23(2).
- [9] YandamuriHaribabu, Narasimha Murthy VV. A New Torque Control Method for Torque Ripple Suppression in BLDC Motor with Nonideal Back EMF. *Indian Streams Research Journal.* 2013; 3(11).
- [10] Calson R, Milchel LM, Fagundes JC. Analysis of torque ripple due to phase commutation in brushless dc machines. *IEEE Trans. Ind. Appl.* 1992; 28(3): 632–638.

- [11] Chuang HS, Ke YL. *Analysis of commutation torque ripple using different PWM modes in BLDC motors*. Conf. Rec. IEEE Ind. Commercial Power Syst. Tech. Conf. 2009: 1–6.
- [12] Zhang XF, Lu ZY. *A new BLDC motor drives method based on BUCK converter for torque ripple reduction*. Proc. IEEE Power Electron. Motion Control, Conf. 2006: 1–4.
- [13] Chen W, Xia CL, Xue M. *A torque ripple suppression circuit for brushless DC motors based on power DC/DC converters*. Proc. IEEE Ind. Electron. Appl. Conf. 2006; 1–4.
- [14] Wei K, Hu CS, Zhang ZC. *A novel commutation torque ripple suppression scheme in BLDCM by sensing the DC current*. 36th IEEE Power Electron. Spec. Conf. 2005; 1259–1263.
- [15] Meng GW, Hao X, Li HS. *Commutation torque ripple reduction in BLDC motor using PWM_ON_PWM mode*. Proc. Int. Conf. Electr. Mach. Syst. Conf. 2009; 1–6.
- [16] Seog-Joo K, Seung-Ki S. *Direct torque control of brushless DC motor with nonideal trapezoidal back EMF*. *IEEE Trans. Power Electron.* 1995; 10(6): 796–802.
- [17] Markadeh, Mousavi SI, Daryabeigi E. *Position sensorless direct torque control of BLDC motor by using modifier*. Proc. 11th Int. Conf. Optim. Elect. Electron. Equipment. 2008; 93–99.
- [18] Gao J, Hu Y. *Direct self-control for BLDC motor drives based on three-dimensional coordinate system*. *IEEE Trans. Ind. Electron.* 2010; 57(8): 2836–2844.
- [19] Geyer T, Papafotiou G, Morari M. *Model predictive direct torque control-Part I: Concept, algorithm, and analysis*. *IEEE Trans. Ind. Electron.* 2009; 56(6): 1894–1905.
- [20] Lianbing L, Hui J, Liqiang Z, Hexu S. *Study on torque ripple attenuation for BLDCM based on vector control method*. Proc. 2th Int. Conf. Intell. Netw. Syst. 2009; 605–608.
- [21] Nam KY, Lee WT, Lee CM. *Reducing torque ripple of brushless DC motor by varying input voltage*. *IEEE Trans. Magn. Apr.* 2006; 42(4): 1307–13210.
- [22] Aghili F, Buehler M, Hollerbach JM. *Optimal commutation laws in the frequency domain for PM synchronous direct-drive motors*. *IEEE Trans. Power Electron.* 2000; 15(6): 1056–1064.
- [23] Aghili F. *Ripple suppression of BLDC motors with finite driver/amplifier bandwidth at high velocity*. *IEEE Trans. Control Syst. Technol.* 2010; 99: 1–7.
- [24] Lu H, Zhang L, Qu W. *A new torque control method for torque ripple minimization of BLDC motors with un-ideal back EMF*. *IEEE Trans. Power Electron.* Mar. 2008; 23(2): 950–958.
- [25] Hanselman D. *Minimum torque ripple, maximum efficiency excitation of brushless permanent magnet motors*. *IEEE Trans. Ind. Electron.* 1994; 41(3): 292–300.
- [26] Aghili F. *Adaptive reshaping of excitation currents for accurate torque control of brushless motors*. *IEEE Trans. Control Syst. Technol.* 2008; 16(2): 356–364.
- [27] Aghili F, Buehler M, Hollerbach JM. *Experimental characterization and quadratic programming-based control of brushless motors*. *IEEE Trans. Control Syst. Technol.* 2003; 11(1): 139–146.
- [28] Ozturk SB, Toliyat HA. *Direct torque and indirect flux control of brushless DC motor*. *IEEE/ASME Trans. Mechatronic.* 2011; 16(2): 351–360.
- [29] Ozturk SB, Alexander WC, Toliyat HA. *Direct torque control of four-switch brushless DC motor with non-sinusoidal back EMF*. *IEEE Trans. Power Electron.* 2010; 25(2): 263–271.
- [30] Rammohan Rao Makineni, Bhaskar CN. *Simulation of cascaded H-bridge multilevel inverter based DSTATCOM*. *TELKOMNIKA Indonesian Journal of Electrical Engineering.* 2014; 12(8): 5720-5728.
- [31] Limits for Harmonic Current Emissions (Equipment Input Current ≤ 16 A Per Phase), Int. Std. IEC 61000-3-2, 2000.
- [32] Singh S, Singh B. *A voltage-controlled PFC Cuk converter based PMBLDCM drive for air-conditioners*. *IEEE Trans. Ind. Appl.* Mar/Apr. 2012; 48(2): 832–838
- [33] Singh B, Singh BN, Chandra A, Al-Haddad K, Pandey A, Kothari DP. *A review of single-phase improved power quality ac-dc converters*. *IEEE Trans. Ind. Electron.* 2003; 50(5): 962–981.
- [34] Singh B, Singh S, Chandra A, Al-Haddad K. *Comprehensive study of single-phase ac-dc power factor corrected converters with high-frequency isolation*. *IEEE Trans. Ind. Informat.* NOV. 2011; 7(4): 540–556.
- [35] Singh S, Singh B. *Power quality improved PMBLDCM drive for adjustable speed application with reduced sensor buck-boost PFC converter*. Proc. 4th ICETET; Nov. 2011; 180–184.
- [36] Gopalaramnam T, Toliyat HA. *A new topology for unipolar brushless dc motor drive with high power factor*. *IEEE Trans. Power Electron.* 2003; 18(6): 1397–1404.
- [37] Jang Y, Jovanović MM. *Bridgeless high-power-factor buck converter*. *IEEE Trans. Power Electron.* Feb. 2011; 26(2): 602–611.
- [38] Huber L, Jang Y, Jovanović MM. *Performance evaluation of bridgeless PFC boost rectifiers*. *IEEE Trans. Power Electron.* May 2008; 23(3): 1381–1390.
- [39] Pearly Catherine J, Balamurugan R. *An approach of power factor correction in BLDC motor drives using cuk derived converters*. *TELKOMNIKA Indonesian Journal of Electrical Engineering.* 2014; 12(12): 8092-8097
- [40] Abbas A Fardoun, Esam H Ismail, Ahmad J Sabzali, Mustafa A. Al-Saffar. *New Efficient Bridgeless Cuk Rectifiers for PFC Applications*. *IEEE Trans. Power Electron.* 2012; 27(7): 3292-3301.