

Voltage Instability Analysis for Electrical Power System Using Voltage Stability Margin and Modal Analysis

Ahmad Fateh Mohamad Nor*, Marizan Sulaiman, Aida Fazliana Abdul Kadir, Rosli Omar

Faculty of Electrical Engineering, Universiti Teknikal Malaysia Melaka,
Hang Tuah Jaya, 76100 Durian Tunggal, Melaka, Malaysia.

*Corresponding author, e-mail: ahmadfatehmohamadnor@gmail.com

Abstract

Voltage instability analysis in electric power system is one of the most important factors in order to maintain the equilibrium of the power system. A power system is said to be unstable if the system is not able to maintain the voltage at all buses in the system remain unchanged after the system is being subjected to a disturbance. The research work presented in this paper is about the analysis of voltage instability of electric power system by using voltage stability margin (VSM), load real power (P) margin, reactive power (Q) margin, reactive power-voltage (QV) and real power-voltage (PV) modal analysis. IEEE 30-bus system has been chosen as the power system. The load flow analysis are simulated by using Power World Simulator software version 16. Both QV and PV modal analysis were done by using MATLAB application software.

Keywords: voltage instability, voltage stability margin, modal analysis, MATLAB

Copyright © 2016 Institute of Advanced Engineering and Science. All rights reserved.

1. Introduction

Voltage instability problem has been a major concern in the operation of electrical power systems. This is due to the fact that it has been one of the main cause of many power blackouts [1-3]. Voltage instability occurs when a power system fails to maintain the voltage at all buses in the system remain unchanged right after the system is being subjected to a disturbance [4-6]. Therefore, it is important to implement voltage instability analysis in order to make sure that the voltage level at all buses is at stable state.

A number of methods to analyse voltage stability has been proposed by previous reseachers. The work presented in this paper used voltage stability margin (VSM) and real power-voltage (PV) and reactive power-voltage (QV) modal analysis to analyze voltage stability in IEEE 30-bus system. VSM is the measure of how far the system can run before experiencing voltage instability [7, 8]. VSM can be obtained from the power-voltage (PV) curve and reactive power-voltage (QV) curve. PV and QV curve are generated by a series of power flow. For every series of power flow, the load of the system is increased until the point where the system is not able to run anymore. The variation values of real power (P) and reactive power (Q) with the value of load is plotted as the PV and QV curve, respectively. Besides that, the PV and QV curve can be used to show the margin of real power (P) load and the margin of reactive power (Q) load. However, this method is more suitable for small power systems only. Generating PV and QV curves for every load bus in large power systems will be very time consuming [4-5], [7-10].

The modal analysis method is more suitable for large electrical power system. It has been introduced by Gao, Morisson and Kundur in the year 1992 [11]. One of the most important task for analyzing voltage instability especially in large electrical power systems is to predict which bus that has the highest tendency towards voltage instability [12]. The modal analysis method can be used for this task. Most of the literatures used only reactive power-voltage (QV) modal analysis to analyse voltage instability [2-3], [11-14]. This paper will also use real power-voltage (PV) modal analysis to analyze voltage instability.

2. Research Method

2.1. Voltage Stability Margin (VSM)

Voltage stability margin (VSM) can be obtained from PV and QV curve as shown in Figure 1 [7, 9]. Smaller value of VSM indicates that the bus of the power system is closer to voltage instability and vice versa. VSM can be calculated by using the following equation [7]:

$$VSM = \frac{V_{\text{initial}} - V_{\text{critical}}}{V_{\text{critical}}} \quad (1)$$

Where V_{initial} is the bus voltage at normal operating condition and V_{critical} is the bus voltage at voltage collapse point.

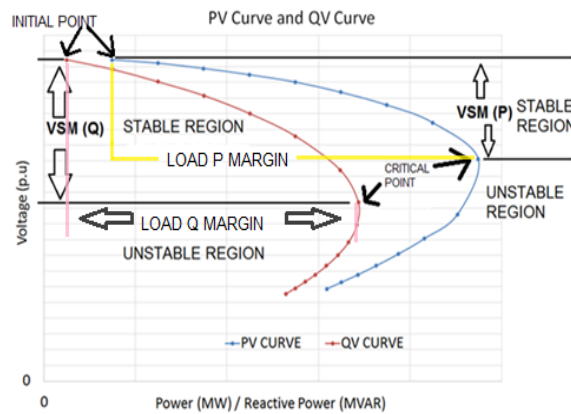

Figure 1. PV and QV curve

2.2. Load Real Power (P) Margin

Load P margin shows the distance of the P load from the base operating point until the critical point. Similar to VSM, load P margin can also be obtained from the PV curve as shown in Figure 1. Equation (2) shows the definition of the load P margin [8].

$$\text{Load P Margin} = (P_{\text{critical}} - P_{\text{initial}}) \quad (2)$$

Where P_{critical} is the value of load (MW) at critical point and P_{initial} is the value of load (MW) at normal operating condition.

2.3. Load Reactive Power (Q) Margin

Load Q margin on the other hand shows the distance of the Q load from the base operating point until the critical point. Similar to VSM and load P margin, load Q margin can also be obtained from the QV curve as shown in Figure 1. Equation (3) shows the definition of the load P margin [8].

$$\text{Load Q Margin} = (Q_{\text{critical}} - Q_{\text{initial}}) \quad (3)$$

Where Q_{critical} is the value of load (MW) at critical point and Q_{initial} is the value of load (MVar) at normal operating condition.

2.4. QV Modal Analysis

QV modal analysis is used to predict the weakest bus in the system based on the Q load. This method consists a few steps that are explained in the following sub-sections.

2.4.1. Reduced Jacobian Matrix (Jr)

The first step in modal analysis method is to obtain the value of the reduced jacobian matrix (Jr) of the system. The Jacobian matrix shown in Equation (4) represents the injected real power (P) and reactive power (Q) in the power system buses [11, 15].

$$\begin{bmatrix} 0 \\ \Delta Q \end{bmatrix} = \begin{bmatrix} J_{P\delta} & J_{PV} \\ J_{Q\delta} & J_{QV} \end{bmatrix} \begin{bmatrix} \Delta\delta \\ \Delta V \end{bmatrix} \quad (4)$$

Where ΔP is the incremental change in bus real power, ΔQ is the incremental change in bus reactive power, $\Delta\delta$ is the incremental change in bus voltage angle and ΔV is the incremental change in bus voltage magnitude.

Then, the Jr can be obtained by substituting the value of ΔP in Equation (4) to 0 as shown in Equation (5). From here, Equation (6) and Equation (7) can be obtained. Equation (8) is formed by substituting Equation (6) into Equation (7).

$$\begin{bmatrix} 0 \\ \Delta Q \end{bmatrix} = \begin{bmatrix} J_{P\delta} & J_{PV} \\ J_{Q\delta} & J_{QV} \end{bmatrix} \begin{bmatrix} \Delta\delta \\ \Delta V \end{bmatrix} \quad (5)$$

$$\Delta\delta = -J_{P\delta}^{-1} J_{PV} \Delta V \quad (6)$$

$$\Delta Q = J_{Q\delta} \Delta\delta + J_{QV} \Delta V \quad (7)$$

$$\Delta Q = \Delta V [J_{QV} - J_{Q\delta} J_{P\delta}^{-1} J_{PV}] \text{ or } \Delta Q = J_r \Delta V \quad (8)$$

Rearranged Equation (8) will form Equation (6) that shows the relationship between the incremental changes of bus voltage with Q load.

$$\Delta V = J_r^{-1} \Delta Q \quad (9)$$

2.4.2. Determination of the Most Critical Mode

The most critical mode of the power system can be determined from the eigenvalues and eigenvectors of Jr. Positive eigenvalues indicate that the power system is stable. The lowest eigenvalue of Jr determines the most critical mode of the power system [3, 11, 13]. Equation 10 [2, 11, 13] depicts their relationship.

$$J_r = \xi \Delta \eta \quad (10)$$

Where ξ is the right eigenvector of Jr, Δ is the diagonal eigenvalue of Jr and η is the left eigenvector of Jr.

2.4.3. Bus Participation Factor

The bus participation factor shows the tendency of a particular bus towards voltage instability. It can be calculated by using Equation (11) [2-3], [11, 13]. The bus participation factor is in matrix form. The row of the matrix indicates the number of the bus. The column of the matrix shows the mode of the power network.

$$P_{ki} = \xi_i \eta_j \quad (11)$$

Where P_{ki} is the participation factor of bus k to mode i, ξ_i is the i^{th} column right eigenvector of Jr and η_j is the j^{th} row of left eigenvector of Jr.

2.5. PV Modal Analysis

Similar to QV modal analysis, PV modal analysis is also used to predict the weakest bus in the system. The only difference is this method is based on the P load. For PV modal analysis, the value of ΔQ in Equation (4) will be set to 0 in order to obtain Jr for PV modal analysis. This is depicted in Equation (12).

$$\begin{bmatrix} \Delta P \\ 0 \end{bmatrix} = \begin{bmatrix} J_{P\delta} & J_{PV} \\ J_{Q\delta} & J_{QV} \end{bmatrix} \begin{bmatrix} \Delta \delta \\ \Delta V \end{bmatrix} \tag{12}$$

The following Equation (13) and Equation (14) are obtained from Equation (12). Equation (15) is formed by substituting Equation (14) into Equation (13).

$$\Delta P = J_{P\delta} \Delta \delta + J_{PV} \Delta V \tag{13}$$

$$\Delta V = - J_{QV}^{-1} J_{Q\delta} \Delta \delta \tag{14}$$

$$\Delta P = \Delta \delta [J_{P\delta} - J_{PV} J_{QV}^{-1} J_{Q\delta}] \text{ or } \Delta P = J_r \Delta \delta, \tag{15}$$

Where,

$$J_r = J_{P\delta} - J_{PV} J_{QV}^{-1} J_{Q\delta}$$

Rearranged Equation (15) will form Equation (16) that shows the relationship between the incremental changes of bus voltage angle with P load.

$$\Delta \delta = J_r^{-1} \Delta P \tag{16}$$

For the PV modal analysis, the same methods as explained in Section 2.4.2 and Section 2.4.3 are used to determine the most critical mode and the bus participation factor, respectively.

2.6. IEEE 30-bus System

The methods explained in Section 2.1 until Section 2.5 are applied to the IEEE 30-bus system as shown in Figure 2. This system consists of one slack bus (Bus 1), five PV buses (Bus 2, Bus 5, Bus 8, Bus 11 and Bus 13) and 24 load buses (Bus 3, Bus 4, Bus 6, Bus 7, Bus 9, Bus 10, Bus 12, and Bus 14 until Bus 30) [16]. For VSM method, the load flow analysis are done by using Power World Simulator software. For modal analysis method, a Matlab program based on [1,17] has been developed to simulate both QV and PV modal analysis onto the IEEE 30-bus system.

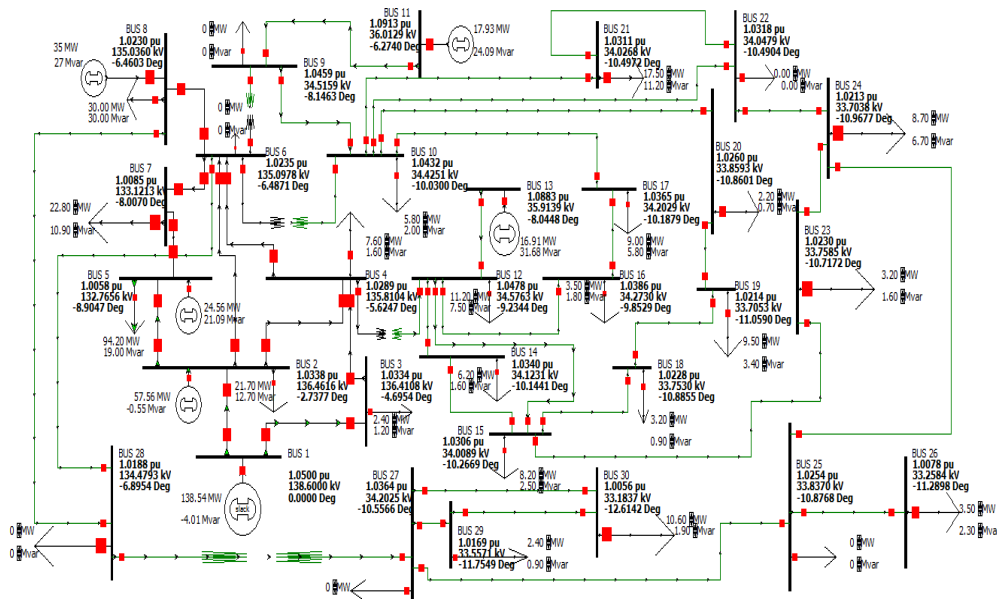

Figure 2. IEEE 30-bus system

3. Results and Analysis

3.1. Voltage Stability Margin (VSM) of IEEE 30-bus System

VSM of the IEEE 30-bus system for both P and Q are listed in Table 1.

Table 1. VSM (P) and VSM (Q) for the IEEE 30-bus System

BUS	VSM (P)	VSM (Q)	BUS	VSM (P)	VSM (Q)
30	0.3309	0.8709	18	0.5106	0.8264
29	0.4120	1.1269	17	0.3971	0.7886
28	0.6296	0.8245	16	0.3199	0.8170
27	0.3344	0.7719	15	0.4077	0.8141
26	0.5295	1.01802	14	0.4141	0.7404
25	0.8094	0.9380	12	0.3408	0.8053
24	0.3531	0.7977	10	0.3674	0.8506
23	0.4021	0.7998	9	0.3428	0.7549
22	0.3966	0.7482	7	0.3035	0.7582
21	0.3936	0.7364	6	0.3280	0.8612
20	0.7529	0.9246	4	0.4453	0.9658
19	0.5779	0.8171	3	0.6139	0.81203

According to Table 1, there are 11 busses that have the lowest VSM (P) value which are under 0.4. Those busses are Bus 30, Bus 27, Bus 24, Bus 22, Bus 21, Bus 17, Bus 16 and Bus 6 until Bus 10. On the other hand, the bus with the lowest value of VSM (Q) recorded are Bus 30, Bus 28, Bus 27, Bus 21 – Bus 24, Bus 17, Bus 14, Bus 9 and Bus 7. Hence, more attention are needed to be given to all of these busses since they are the closest towards voltage instability.

3.2. Load Real Power (P) Margin and Load Reactive Power (Q) Margin

Load real power (P) margin and load reactive power (Q) margin of the IEEE 30-bus system are listed in Table 2.

Table 2. Load P Margin and Load Q Margin for the IEEE 30-bus System

BUS	Load P Margin	Load Q Margin	BUS	Load P Margin	Load Q Margin
30	40.0	34.67	18	109.70	81.32
29	50.20	38.39	17	158.00	111.02
28	272.00	208.00	16	140.00	100.97
27	110.00	76.00	15	148.00	109.58
26	39.63	31.99	14	110.00	84.92
25	91.00	69.00	12	200.00	138.93
24	120.00	90.92	10	194.00	136.22
23	110.00	82.25	9	220.00	151.00
22	157.00	112.86	7	260.00	211.14
21	158.00	112.69	6	375.00	312.00
20	112.09	86.32	4	428.00	331.65
19	108.34	81.34	3	432.11	311.91

According to Table 2, Bus 26, Bus 29 and Bus 30 have the lowest values of both load P margin and load Q margin. This shows that these three busses are the weakest bus. It is also can be seen in Table 2 that the value of load Q margin is less than the value of load P margin. This shows that load Q margin is more sensitive towards voltage instability compared to load P margin.

3.3. QV Modal Analysis

It is explained in Section 2.4 that the QV modal analysis is about the relationship between incremental changes of voltage with the Q load. Table 3 shows the voltage values and phase angle values at all buses obtained from the load flow analysis. The load flow are ran by using Power World Simulator software. Table 3 shows the eigenvalues of J_r for QV modal analysis. These values are obtained by using Matlab application software.

Table 3. Voltage and phase angle values at all buses

BUS	VOLTAGE (PER UNIT)	PHASE ANGLE (DEGREE)	BUS	VOLTAGE (PER UNIT)	PHASE ANGLE (DEGREE)
1	1.05000	0.00	16	1.03858	-9.85
2	1.03380	-2.74	17	1.03645	-10.19
3	1.03342	-4.70	18	1.02282	-10.89
4	1.02887	-5.62	19	1.02137	-11.06
5	1.00580	-8.90	20	1.02604	-10.86
6	1.02347	-6.49	21	1.03111	-10.50
7	1.00849	-8.01	22	1.03176	-10.49
8	1.02300	-6.46	23	1.02299	-10.72
9	1.04594	-8.15	24	1.02133	-10.97
10	1.04319	-10.03	25	1.02536	-10.88
11	1.09130	-6.27	26	1.00783	-11.29
12	1.04777	-9.23	27	1.03644	-10.56
13	1.08830	-8.04	28	1.01878	-6.90
14	1.03403	-10.14	29	1.01688	-11.75
15	1.03057	-10.27	30	1.00557	-12.61

Table 4. Eigenvalues of Jr for QV Modal Analysis

Eigenvalue	Mode of power system	Eigenvalue	Mode of power system
111.1776	1	13.7461	13
98.7869	2	13.4183	14
66.4613	3	11.0785	15
58.5047	4	0.5102	16
37.1354	5	1.0318	17
34.9031	6	1.7820	18
23.4533	7	8.6526	19
23.0517	8	7.5999	20
19.5602	9	3.5383	21
19.0777	10	4.0004	22
18.0411	11	6.2880	23
16.5580	12	5.4417	24

Table 4 shows that all of the eigenvalues are positive. As stated in Section 2.4.1, positive eigenvalues point out that the power system is stable. Table 4 also tells that the 16th eigenvalue is the lowest which is 0.5102. Therefore, Mode 16 is the most critical mode for this power system. The bus participation factor for Mode 16 is calculated. The results are shown in Figure 3. Figure 3 conveys that Bus 26, Bus 29 and Bus 30 have high participation factor with Bus 30 is the highest which is 0.2064. This means that Bus 30 has the highest contribution towards voltage instability even though the voltage magnitude of Bus 30 shown in Table 3 is good (1.0057 per unit).

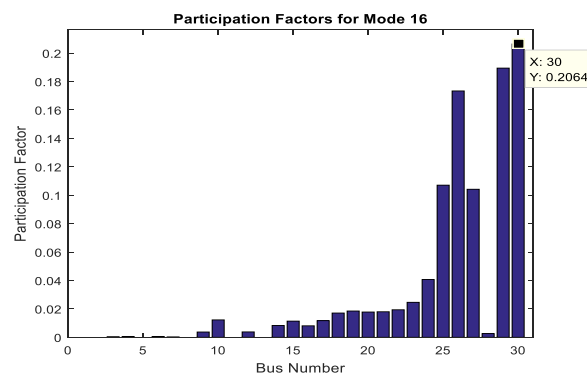

Figure 3. The bus participation factor for Mode 16

Figure 3 shows that only the load buses that possess the participation factor. This is because the QV modal analysis method focuses on the relationship between the incremental

changes of voltage and reactive power. Since the voltages of the slack and PV buses are fixed prior to the load flow analysis, no participation factor is considered on the slack and PV buses.

3.3. PV Modal Analysis

Table 5 shows the eigenvalues of J_r for PV modal analysis.

Table 5. Eigenvalues of J_r for PV Modal Analysis

Eigenvalue	Mode of power system	Eigenvalue	Mode of power system
118.0936	1	13.5507	16
99.5725	2	0.2349	17
71.6721	3	0.7847	18
59.5653	4	9.2161	19
37.9914	5	8.9096	20
36.8488	6	8.0619	21
34.0705	7	7.3587	22
32.0763	8	1.7977	23
25.6003	9	2.3278	24
24.2339	10	2.8922	25
21.2960	11	3.6550	26
19.1765	12	6.2864	27
17.6232	13	4.3285	28
16.9089	14	5.2329	29
14.0589	15		

Table 5 shows that the system is also stable since all of the eigenvalues are positive. It also tells that for this PV modal analysis method, the 17th eigenvalue is the lowest which is 0.2349. Hence, mode 17 is the most critical mode for this power system.

The bus participation factor for mode 17 is calculated. The results are shown in Figure 4. Figure 4 depicts that Bus 26, Bus 29 and Bus 30 have high participation factor with Bus 26 being the highest which is 0.06617. This delineates that bus 26 is closest towards voltage instability compared to other buses.

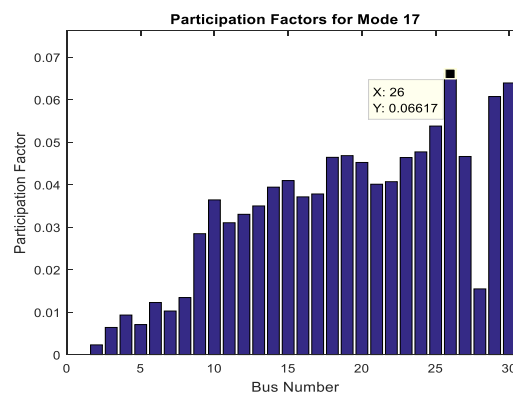

Figure 4. The bus participation factor for Mode 17

All buses shown in Figure 4 have participation factor except for Bus 1 (slack bus). This is because the PV modal analysis method considers the relationship between the incremental changes of voltage angle and real power as shown in Equation 16. Since the voltage angle of the slack bus are fixed prior to the load flow analysis, no participation factor is considered on Bus 1 for PV modal analysis method.

In comparison with QV modal analysis in Figure 3, PV modal analysis produces more busses with high participation factor. This the reason in terms of accuracy, QV modal analysis is more accurate in analyzing voltage instability than PV modal analysis.

4. Conclusion

The study conducted in this paper show that all of the methods used in this study (VSM, load P & Q margin, and PV & QV modal analysis) are very reliable to analyse voltage instability of the IEEE 30-bus system. Both VSM (P) and VSM (Q) gave a total of 21 weakest busses - 11 busses from VSM (P) and 10 busses from VSM (Q). Later on this paper, both load P margin and Q margin managed to narrow down the weakest bus to the total of six busses only (three busses each). QV and PV modal analysis predicted three weakest busses each- Bus 26, Bus 29 and Bus 30. Hence, it is safe to say that Bus 30 has the highest tendency towards voltage instability. This is due to the fact that Bus 30 is on every list of weakest bus of all of the methods used in this study.

Acknowledgements

The authors are thankful to the Universiti Teknikal Malaysia Melaka (UTeM) and the Ministry of Higher Education Malaysia for providing financial assistance under the grant FRGS/2/2014/TK03/FKE /01/F00238.

References

- [1] Mobarak YA. Voltage Collapse Prediction for Egyptian Interconnected Electrical Grid EIEG. *International Journal on Electrical Engineering and Informatics*. 2015; 7(1): 79–88.
- [2] Telang B, Khampariya P. Voltage Stability Evaluation Using Modal Analysis. *International Journal of Scientific Research Engineering & Technology (JSRET)*. 2015; 4(4): 408-411.
- [3] Enemuoh FO, Onuegbu JC, Anazia EA. Modal Based Analysis and Evaluation of Voltage Stability of Bulk Power System. *International Journal of Engineering Research and Development*. 2013; 6(12): 71-79.
- [4] Sulaiman M, Nor AFM. PV and QV Curves Approach for Voltage Instability Analysis on Mesh-Type Electrical Power Networks Using DIgSILENT. *MAGNT Research Report*. 2015; 3(6): 36-42.
- [5] Sulaiman M, Nor AFM, Bujal NR. Voltage Instability Analysis on PV and QV Curves for Radial-Type and Mesh-Type Electrical Power Networks. *International Review of Electrical Engineering (IREE)*. 2015; 10(1): 109-115.
- [6] Bujal NR, Sulaiman M, Omar R. *A Graphical User Interface (GUI) for Voltage Stability Analysis*. Conference In Education - Technical Vocational Education and Training. Mersing. 2014: 1441-1461.
- [7] Basu S, Gupta C, Chowdhuri S. Voltage Stability Margin (VSM) and Maximum Loading Point (MLP) Of A Multi-Bus System Before and After Compensation. *International Journal of Engineering Research and Development*. 2013; 5(7): 30-35.
- [8] Zhou DQ, Annakkage UD, Rajapakse AD. Online Monitoring of Voltage Stability Margin Using an Artificial Neural Network. *IEEE Transactions On Power Systems*. 2010; 25(3): 1566-1574.
- [9] Zhichun Y, Jian L, Kaipei L, Zilin W, Hanyang G. Analytical Method of Distributed Generation on Static Voltage Stability. *TELKOMNIKA Indonesian Journal of Electrical Engineering*. 2013; 11(9): 5018-5029.
- [10] Thannimalai P, Raman RR, Nair P, Nithiyananthan K. Voltage Stability Analysis and Stability Improvement of Power System. *International Journal of Electrical and Computer Engineering (IJECE)*. 2015; 5(2): 189-197.
- [11] Gao B, Morison GK, Kundur P. Voltage Stability Evaluation using Modal Analysis. *IEEE Transactions on Power System*. 1992; 7(4): 1529-1542.
- [12] Amroune M, Bourzami A, Bouktir T. Weakest Buses Identification and Ranking in Large Power Transmission Network by Optimal Location of Reactive Power Supports. *TELKOMNIKA Indonesian Journal of Electrical Engineering*. 2014; 12(10): 712-730.
- [13] Sharma C, Ganness MG. *Determination of the Applicability of using Modal Analysis for the Prediction of Voltage Stability*. Transmission and Distribution Conference and Exposition. Chicago. 2008: 1-7.
- [14] Morison GK, Gao B, Kundur P. Voltage Stability Analysis using Static and Dynamic Approaches. *IEEE Transactions on Power Systems*. 1993; 8(3): 1159-1171.
- [15] Saadat H. *Power System Analysis*. Singapore: McGraw-Hill Inc. 2004.
- [16] Pai MA. *Computer Techniques in Power System Analysis*. Second Edition. New Delhi: Tata McGraw-Hill. 2006.
- [17] PRAVI. Newton-Raphson Loadflow. Available from: <http://www.mathworks.com/matlabcentral/fileexchange/21059-newton-raphson-loadflow>.