

Case Study of line loss Reduction in TNEB Power Grid

S.Sambath^{*1}, P.Palanivel², C.Subramani³, S.P.K.Babu⁴, J.Arputhavijayaselvi⁵

^{1,4}Periyar Maniammai University, Vallam, India

²MAMCE, Trichy, India

³SRM University, Chennai, India

⁵Kings College of Engineering, Pudukkottai, India

*Corresponding author, e-mail: yeses.eng@gmail.com

Abstract

Unbundling of Electricity Boards in India into small units (corporations) have created opportunities for involvement of independent power generation companies. Remarkable achievements and improvements are expected in power quality especially in the southern part of the country where more power shortage, power quality low and serious power losses along the transmission and distribution lines of the power system. The power system utilities are increasing every day, to enhance the distribution power quality and maintain the voltage stability is a challenging task in the complex distribution. This can be achieved through the Distributed Generation (DG). DGs are the final link between the high voltage transmission and the consumers. This will effectively improve the active power loss reduction. This paper represents the technique to enhance the power qualities and minimize power losses in a distribution feeder by optimizing DG model in terms of size, location and operating point of DG. The proposed technique has been developed with considering load characteristics and representing constant current model. The effectiveness of the proposed technique is tested and verified using MATLAB software on long radial distribution system in Tamil Nadu (India).

Keywords: distributed generation, optimization, DG placement, voltage profile, power losses

Copyright © 2014 Institute of Advanced Engineering and Science. All rights reserved.

1. Introduction

Distributed generation (DG) is defined as installation and operation of small modular power generating technologies that can be combined with energy management and storage systems. It is used to improve the operations of the electricity delivery systems at or near the end user [1]. These systems may or may not be connected to the electric grid. Distributed generation system can employ a range of technological options from renewable to non-renewable and can operate either in a connected grid or off-grid mode. The size of a distributed generation system typically ranges from less than a kilowatt to a few megawatts.

There are various methods used for loss reduction in power system network like feeder reconfiguration, capacitor placement, high voltage distribution system, conductor grading, and DG unit placement. All these methods are involved with passive element except DG unit placement. Both capacitors and DG units reduce power loss and improve voltage regulation, but with the DGs loss reduction almost doubles that of Capacitors [2].

The issue of DG placement and sizing is of great importance in the present days of energy generation crisis, as its installation at non optimal location tends to increase system losses. The increase in these losses means increase in costs and hence has a negative effect on the planner's desired objective [3]. For this reason it is necessary to employ optimization techniques that can find the best location for DG installation. Research outputs have shown that improper allocation and sizing can result in high power losses and can jeopardize the system performance or results in instability [4]. Many research and investigation have been done in the area of optimal DG unit placement for loss minimization in distribution system. In [5] the authors have shown the potential of DG with power electronic interface to provide ancillary services such as reactive power, voltage sag compensation and harmonic filtering. The work has demonstrated the ability of DG to compensate voltage sag that can occur during fault in the power system. However, the work could not quantify the amount of power loss reduction due to DG installation in the network. Also the authors in [6] have used convolution technique to evaluate the probability of quantifying the benefit of voltage profile improvement involving wind

turbine generation. According to [7] non-iterative analytical approaches can be used to optimally place DG in both radial and meshed systems for the minimization of power losses. All the approaches above are mathematical in nature and are found to be complex. A similar work in [8] has proposed an approach for the computation of annual energy losses for different penetration levels of DG in a distribution network. The authors have found that when DG units are dispersed along the network feeders the high losses are reduced up to a certain value of the DG capacity and beyond which the loss tend to increase. This idea was used to optimize DG capacity for minimum power loss.

2. Problem Formation

The complexity of the distribution system and the power quality maintaining is achieved by allocating the DGs in the distribution feeder. The proposed technique is based on optimal placement of DG units, which is concentrate with specifications like based on their size and location. The stability of the distribution system is depends on the following factors.

- a) Voltage stability
- b) Real and Reactive power
- c) Power loss

3. Planning for Decentralized Generation

The conventional wisdom has indicated that large generation stations offer significantly better economies of scale. However, such calculations must be recalibrated when faced with the state of the power grid in many emerging economies in the states in India, viz., large distributed (rural) load, high T&D losses (including theft), limited capacity availability, and dramatically poor supply conditions. In such cases, a thorough analysis should be made for the policies, technical specifications, and economic analysis behind use of DG [9].

3.1. Current System

The utilities interconnect with the renewable DG generators at high voltages ($> 110\text{kV}$, $> 33\text{ kV}$ or, $> 11\text{ kV}$, depending on the state lowest “transmission” voltage level). This gives the utility the flexibility to divert the power in the grid. However, the local area does not benefit significantly from decentralized generation and moreover, there is no discernible improvement in the power quality and loss reduction or in utility’s revenues even though the utility purchases expensive power from the DG units [10, 11].

3.2. Proposed System

The utilities’ policy for DG units appears to be one-sided and overlooks the possible benefits of decentralized power generation in remote rural feeders. In this paper we examine the opportunities with decentralized power generation in rural areas and attempt a more rational basis for framing utilities’ policies towards the DG units. In particular, we address the following issues:

- a) Impact of DG on the voltage profiles, reactive power and power factor.
- b) Technical distribution losses

4. Simulation and Analysis

4.1. Methodology

The approach of this study is to conduct a three-phase AC load flow analysis [12] of a rural distribution feeders in 110/11KV Ullikkottai substation (TANGEDCO) in Tiruvarur district of Tamil Nadu in (Figure 1). This is representative of a typical distribution feeders in rural sub station and the results will therefore have a wider applicability.

There are five feeders in the substations feeds various villages mostly($>70\%$) to the agricultural. Each feeder has a step-down transformer for 415V/240V and the transformer ratings are 25KVA, 63KVA, or 100KVA. The distance between the sub-station and the tail end feeder is about 14km and the peak demand is 18MW (Table 1). The feeder’s load is mostly agriculture pumps and motors that are inductive and often operate at power factor as low as 0.75.

Table 1. Details of the Ullikkottai 110/11 KV Sub-Station

Substation Transformer	110/11 Kv,20 MVA
Total number of feeders	5
Peak Load	18 MW
Transformers in the feeder	25 KVA, 63 KVA, 100 KVA

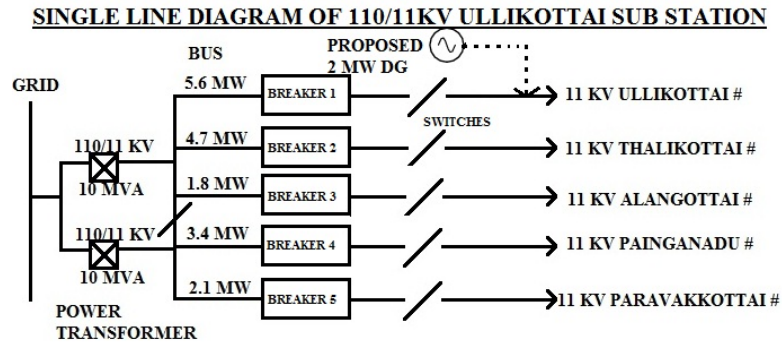

Figure 1. Single Line Diagram of 110/11KV Sub-Station Ullikkottai in Thiruvarur district, Tamil Nadu (Peak demand 18 MW)

There are four main categories of consumers: Domestic, commercial, industrial and agricultural (irrigation pumps). The kWh consumed by the first three categories are metered and they are charged on a per kWh basis, while agricultural consumers are not metered and they pay on a flat rate basis (Rs 1750/ /HP/Annum). Since Agriculture pumps are not metered, there is no data available on their annual power consumption and it is estimated by sample metering.

4.2. Proposed System

This proposed method places the DG based on DG current usage maximization and reduction of current sourced from grid for power loss improvement. The intention is to introduce an approximation method that will identify the size of DGs and the optimal location based on maximization of what is called power loss reduction (PLR) value. Generally losses associated with active current in single-source radial networks cannot be minimized as the source has to supply all the active power. However, if DGs are placed in the network, the active branch current sourced from the single source is reduced due to the active current from the DG that balances the demand. The consequences are loss reduction due to current reduction sourced from the single source (main feeder) improved power factor and voltage profile. The power loss reduction is therefore the difference between loss associated with active current when with out DG and when with DG is connected. Thus the value of the power losses and the DG current that gives maximum loss reduction are as in Equation (1) and (2) respectively

$$P_{loss} = \sum_{i=1}^n |I_i|^2 R_i \quad (1)$$

$$I_{DG} = \frac{\sum_{i=1}^n D_i I_{ai} R_i}{\sum_{i=1}^n R_i} \quad (2)$$

However, significant loss reduction will occur at the feeders with DG connection. Thus, the new total power loss in the network with the DG connection is as expressed in the following equations.

$$P_{loss} = \sum_{i=1}^n |I_i^{new}|^2 R_i \quad (3)$$

$$P_{loss-new} = \sum_{i=1}^n (I_i - I_{DG})^2 R_i \quad (4)$$

$$P_{loss-new} = \sum_{i=1}^n (I_i - I_{DG})^2 R_i \quad (5)$$

Where $J=1$ is for feeder with DG, otherwise $J=0$. Therefore, the PLR value with DG connection at bus ' i ' is:

$$P_{loss-new} = \sum_{i=1}^n I_i^2 R_i - 2J I_i I_{DG} R_i - J I_{DG}^2 R_i \quad (6)$$

$$PLR_i = P_{loss-new} - P_{loss} \quad (7)$$

Equation (7) is the Objective function that maximizes power losses reduction value in the network. The optimization method that uses PSO is developed based on a computational technique as extensively discussed in [13, 14]. The real power losses was randomly generating in an initial population of particles with random positions and velocities in the solution space. Each of the Particles is subjected to constraints specified while running the power flow in order to calculate the power losses.

4.3. AC Load Flow Study

The approach is to conduct a three-phase AC load flow analysis for this feeder using the Gauss-Seidel algorithm. It was first carried out a base case scenario (without DG) to obtain the voltage profiles, distribution losses and then considered the impact of a DG installed in the feeder.

For simplicity, the following assumptions are made:

- On-line load: This is defined as the fraction of sanctioned load that is connected at any instant. This is varied between 0.40 and 0.8, parametrically.
- Power Factor: The load power factor is not known and we varied it parametrically between 0.7 and 0.90. This appears reasonable given the majority of the load are irrigation pump sets.
- Theft is defined as the fraction of on-line consumption that is unauthorized. We have fixed this at 14% of the on-line load.
- Transformer Losses: We have ignored the losses in each of the transformers because of non-availability of data.
- DG unit is capable of supplying power at both leading and lagging power factors.

Table 2. Assumptions for the Three-phase AC Load Flow Analysis

Variable	Value or Range
On-Line Load	40% - 80% of the sanctioned load
Theft	14% of on-line load
Power Factor	0.70 – 0.90 lagging

5. Results

5.1. Voltage and Distribution Losses

5.1.1. Current System

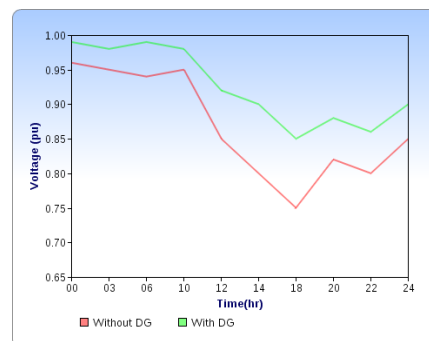

Figure 2. Shows the Voltage Profiles (per unit basis, or pu) of the Common Bus under Heavy Load Conditions (75%) with the Power Factor Varying between 0.75 and 0.9

Figure 2 shows the current system the decentralized power generation source placed in the beginning of the feeder ie at sub-station the calculated distribution losses as a function of the power factor under moderate loading condition of 60% with 14% theft. Depending on the power factor, the technical distribution losses are between 8.5% and 12.5%. In most rural feeders, the power factor is 0.75–0.8 and therefore distribution losses are likely to be at least 10% under normal loading conditions. The commercial losses including theft were assumed to be 14% and hence the total losses (or unaccounted energy) in the feeder are 20%. When adding the technical transmission losses, estimated over 9%, it was see that the total losses are unacceptably high (30%). One contribution of this study is therefore to quantify the technical distribution losses for rural feeders from first principles, something not shown in publications before.

Figure 3 shows the daily MVAR and MW of the system taken for the study.

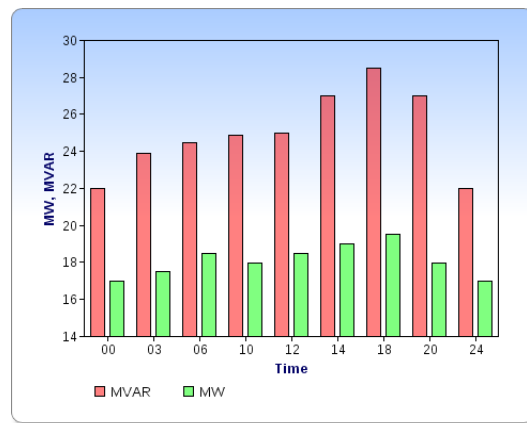

Figure 3. Daily MVAR and MW of 110/11KV Ullikkottai Sub-Station

5.1.2. Proposed System

Now we consider the impact of a decentralized generator located in the middle of the feeder 1.

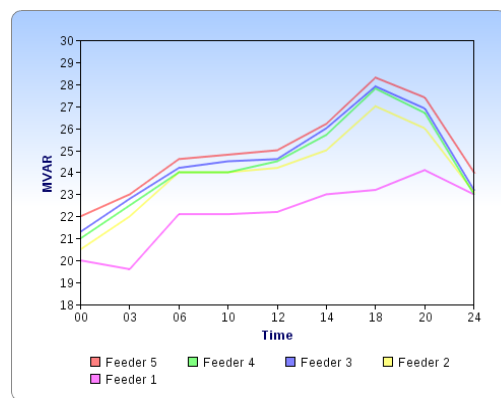

Figure 4. Impact of a Decentralized Generator Placed in Various Feeders. The generator is varied from 1 MW to 3MW. (On-Line load is 60%, power factor 0.8).

Figure 4 shows the impact of a decentralized power generation source placed in the feeder at Bus # 60. The choice of the bus was made on the basis of it being centrally located in the feeder, and almost equidistant from all the branches. The generator power varied from 0 to

4MW with a power factor of unity. As expected, the voltage profiles improve considerably throughout the feeder. For most of the buses, even with just a 1MW plant, the voltages fall within acceptable norms. The same effect is also seen when a bank of capacitors is installed, which supplies only reactive power. Reactive power is therefore very important for voltage support in the context of rural feeders that have low power factors. This becomes relevant in the following sections as the generators could also act as sources of reactive power.

The voltage of the system under study will increased and reactive components reduced when the DG is connected in the feeder 1 ie 11 KV Ullikkottai feeder .Hence the feeder load is 5.6 MW. When we connect 3 MW DG in the feeder is optimum to maintain the feeder voltage and reduce the reactance within the accepted level.

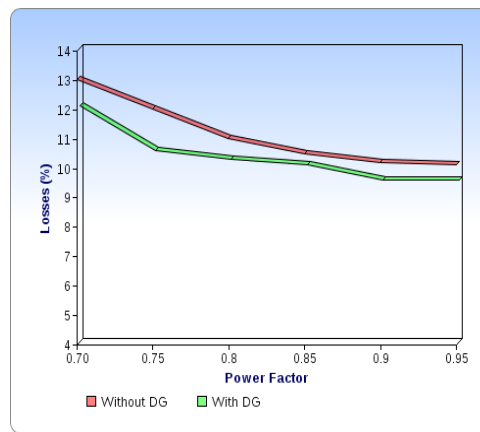

Figure 5. Technical Distribution Losses (I^2R) in the Feeder under Moderate Loading of 60% without DG and with DG as a Function of the Overall Power Factor

Therefore, appropriate sizing and locating a decentralized generator improves the quality of power supplied to the feeder and also reduces the distribution losses. Using photovoltaic generation and wind power, other researchers have reported similar results that reduce distribution losses [15, 16]. The above discussion suggests that distributed generation close to the rural load centers benefits both the local consumers (improved power quality) as well as the utility (lower losses) and helps to reduce peak demands. It opens the possibility of creating rural micro-grids, or regions of stable and good quality power supply within the utility's network. Rural electricity cooperatives can be formed at a district level, wherever decentralized generation is possible. In this context, biomass and natural gas based distributed generators can play an important role. The farmers get paid for the biomass they supply to the power plant and in return, they pay for the power consumed.

6. Conclusion

In this paper we examined opportunities for distributed power generation in rural Tamil Nadu India. The results obtained show that power losses of the system is considerably reduced, the power quality enhanced and peak load reduced by finding optimum location of a decentralized power generator. There is a significant improvement in the voltage profiles and reduction of technical distribution losses. This creates a possibility of setting up rural micro-grids or rural electricity cooperatives with Gas based and non conventional power generators. From the experimental and practical implemented proposed system, clearly identified that the percentage reduction in line loss, voltage improvements and peak clippings were achieved. Our study is limited to only in Tamil Nadu state in India. In future work our study will be expanded to all states in India using the above techniques for demand side management in whole country and increase the revenue of the utilities.

References

- [1] P Chiradeja, R Ramakumar. An Approach to Quantify the Technical Benefits of Distributed Generation. *IEEE Transactions on Energy Conversion*. 2004; 19(4): 764–773.
- [2] W Caisheng, MH Nehrir. Analytical Approaches for Optimal Placement of Distributed Generation Sources in Power Systems. *IEEE Transactions on Power Systems*. 2004; 19(4): 2068 – 2076.
- [3] Momoh J, Yan Xia, Boswell GD. *An approach to determine Distributed Generation (DG) benefits in power networks*. Power Symposium. 2008. NAPS.
- [4] Akorede MK, Himaz H, Ari I, Abkadir MZA. Effective method for optimal allocation of distributed generation units in meshed electric power systems Generation. *Transmission & Distribution IET*. 2011; 5(2): 6-287 Feb.
- [5] Joos G, Ooi BT, McGillis D, Galiana FD. Engineering Society Summer Meeting. 2000; 1762-1767.
- [6] L Ramesh, SP Chowdhury, S Chowdhury, AANatarajan. Distribution Feeder Restructuring for Better Voltage Regulation and Line Loss Reduction. *IEEE Powercon*. 2008.
- [7] Wang Caisheng, Hashem M. Analytical Approaches for Optimal Placement of Distributed Generation Sources in Power System. *IEEE Transaction on Power System*. 19(4): 2068-2076 2004
- [8] Quezada, Victor H Mendez Juan River Abbad, Toma's Gomez San Roman. Assessment of Energy Distribution Losses for Increasing, Penetration of Distributed generation. *IEEE Transaction on Power System*. 2006; 21(2): 533-540.
- [9] *Impact of Distributed generation over power losses on Distribution system* by fracisco M Gonzlez-Longart.
- [10] Datas collected from various sources in TNEB training institutes and LD centre Chennai.
- [11] N Mithulananthan, Than Oo, Le Van Phu. *Distributed Generator Placement in Power Distribution System Using Genetic Algorithm to Reduce Losses*. Thammasat Int. J. Sc. Tech., 2004; 9: 55-62.
- [12] A Lakshmi Devi, B Subramanyam. *A New Hybrid Method for Loss Reduction and Voltage Improvement In Radial Distribution System- A Case Study*. *i-manager's journal on Electrical Engineering*. 2008; 1(3): 64- 68.
- [13] Rafiei M, Zadeh MS. *Optimization of a typical biomass fueled power plant using Genetic algorithm and binary particle swarm optimization*. 17th Conference on Electrical Power Distribution Networks (EPDC). 2012; 1-10 2nd.
- [14] Fan HY, Shi Y. *Study of Vmax of the Particle Swarm Optimization Algorithm*. Proceedings of the Workshop on Particle Swarm Optimization. Indianapolis. Purdue School of Engineering and Technology, IUPUI (in press). 2001.
- [15] Musa H, Adamu SS. *PSO Based DG Sizing for Improvement of Voltage Stability Index in Radial Distribution Systems*. Proceedings of 2nd IASTED Int. Conference on Power and Energy Systems and Application (PESA 2012). 2012; 175-180.
- [16] H Musa, SS Adamn. *Voltage improvement and Power loss reduction for a Typical sub-transmission region using optimally placed and sized DG*, International journal of Electrical, Electronics and Computer systems. 2013.