

# Performance Analysis of a Hybrid MIMO Technique for High Data Rate Wireless Communication System

Kehinde Odeyemi<sup>\*1</sup>, Erastus Ogunti<sup>2</sup>

<sup>1</sup>Department of Electrical and Electronic Engineering, University of Ibadan, Nigeria

<sup>2</sup>Department of Electrical and Electronic Engineering, Federal University of Technology, Akure, Nigeria

\*Corresponding author, e-mail: kesonics@yahoo.com

## Abstract

The demand for higher data rate and better quality of service (QoS) in wireless communications was growing fast in the past few years. Obtaining these requirements becomes challenging for wireless communication systems due to the problems of channel multi-path fading, higher power and bandwidth limitations. One of the most promising solutions to this problem is Multiple Input Multiple Output (MIMO) system. This paper proposed a combined spatial multiplexing MIMO scheme with beamforming for high data rate wireless communication. The proposed transmission scheme combines the benefits of both techniques and the system was able to transmit parallel data streams as well as providing beamforming gain. Actually, these diverse techniques, share the same requirement of multiple antenna elements, but differ in the antenna element spacing necessary for the different schemes to work. Thus, smart antenna array was proposed as a possible solution and was adopted at the both transmitter and the receiver. The hybrid technique provides higher spectral efficiency and improve better Bit error rate (BER) of the system than the conventional MIMO, spatial multiplexing and beamforming techniques under the same simulation environment.

**Keywords:** MIMO, spatial multiplexing, beamforming, smart antenna, BER, spectral efficiency

Copyright © 2014 Institute of Advanced Engineering and Science. All rights reserved.

## 1. Introduction

The demand for high data multimedia services is fast growing in the past few years and several techniques approaches have been studied to enhance bit rate and to improve the reliability of any wireless system. The available bandwidth and the maximum radiated power are subject to fundamental physical constraints as well as regulations and are also limited. As a large increase in channel capacity and high transmission rates for wireless communications, the technologies for the power saving and efficient frequency usability are required. In a Single-Input Single-Output (SISO) antenna system where there is only one antenna at both transmitter and receiver suffers a bottleneck in terms of capacity due to the Shannon-Nyquist criterion [1, 2]; while future wireless services demand much higher data bit-rate transmission with smaller bit error rate. In order to increase the capacity of the SISO systems to meet such demand, the bandwidth and transmission power have to be increased significantly.

Presently, a lot of research developments have shown that using Multiple Input Multiple Output (MIMO) systems could improve system reliability and increase the channel capacity in wireless communication substantially without increasing the transmission power and bandwidth [3, 4]. There are three typical approaches in the MIMO system and these include spatial multiplexing (SM), spatial diversity and beamforming. The spatial diversity technique is predominantly aimed at improving system reliability because it is used to combat channel fading, SM technique is capable of increasing data transmission rate while beamforming provides a significant increase in performance of wireless communication systems by focusing on the signal energy in a particular direction to increase the received SNR and also reduce interference [5]. Considering the advantages of these various MIMO techniques, there is a need to integrate them so that the whole wireless system can benefit from these techniques.

In this paper, a hybrid MIMO technique is conceived as a promising solution for spectrally efficient transmission technique for wireless communication system. These diverse techniques, share the same requirement of multiple antenna elements, but differ in the antenna element spacing necessary for the different schemes to work. That is, under the beamforming

technique, the antenna spacing must be small in order to provide the required high channel correlation but spatial multiplexing and spatial diversity techniques require the antenna spacing to be large enough that the correlation between the MIMO channels is low [6]. Thus, the use of smart antenna arrays at transmitter and/or receiver terminals provides a possible solution in this work for the antenna spacing problem so that the system would have high-correlation and low-correlation scenarios simultaneously necessary for these different techniques.

Various hybrid MIMO techniques scheme have been proposed in the past to improve the performance of wireless communication systems. Most of them focus on combining beamforming with diversity techniques [7-10]. However, this combined technique can only enable a system to achieve both diversity gain and beamforming gain. This can improve the system performance, without improving the system spectrum efficiency since both techniques are mainly to combat fading. Based on this limitation, a system of hybridizing beamforming with spatial multiplexing technique is proposed. This proposed technique improved the system spectral efficiency significantly, as well as guaranteeing the system BER performance.

**2. System Model**

A smart antenna MIMO system was proposed for high data rate wireless system as illustrated in Figure 1 and was configured in such a way that both the transmitter and the receiver were equipped with one or more smart antenna arrays. The transmitter has  $M_T$  antenna arrays with each array having  $N$  antenna elements and there are  $M_R$  antenna arrays at the receiver with each array having  $K$  antenna elements. We assumed that the channel state information (CSI) is only known to the receiver and that the channel has the Rayleigh fading distribution; and spatially uncorrelated complex Gaussian noise is added to the faded signal at the receiver. The spacing between the antenna arrays was made to be more than  $10\lambda$  while the antenna element spacing of each antenna array is a half wavelength ( $\lambda/2$ ). The vectors  $W$  and  $Z$  are called the transmit beamforming and receive beamforming vectors, respectively

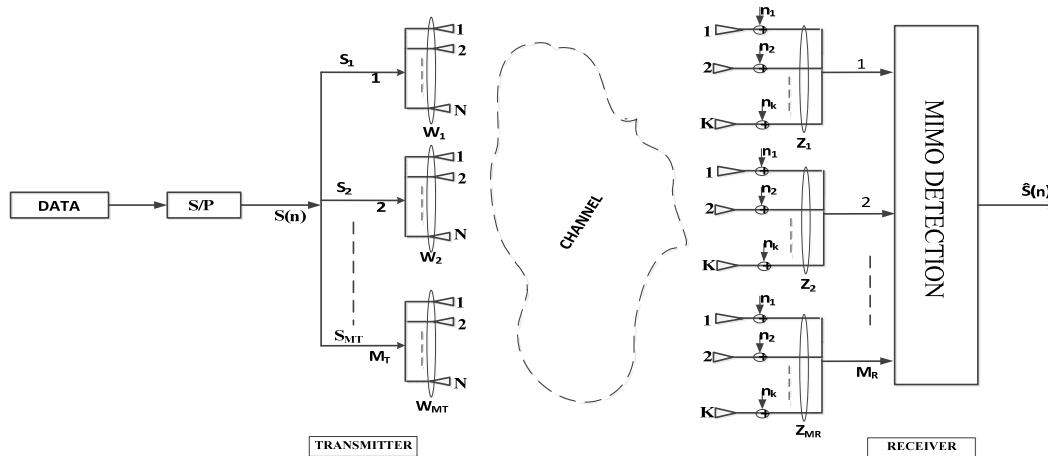

Figure 1. Proposed MIMO Wireless System with Smart Antenna Array

**3. System Analysis**

Conventionally, the MIMO channel impulse response of MIMO systems with  $M_T$  transmit antennas and  $M_R$  receive antennas is given as [11]:

$$H = \begin{pmatrix} h_{11} & h_{12} & \dots & h_{1M_T} \\ h_{21} & h_{22} & \dots & h_{2M_T} \\ \vdots & \vdots & \dots & \vdots \\ h_{M_R1} & h_{M_R2} & \dots & h_{M_R M_T} \end{pmatrix}_{M_R \times M_T} \tag{1}$$

Where  $h_{i,j}(\tau)$  shows the channel impulse response between the  $j^{th}$  transmitter to the  $i^{th}$  receiver element and is given as:

$$h_{i,j}(\tau) = \sum_{n=1}^L \alpha_n \delta(\tau - \tau_n) \tag{2}$$

Where  $h_{i,j}(\tau)$  multipath channel impulse response, L is the number of paths,  $\alpha_n$  shows the amplitude of the  $n^{th}$  path and it obeys independent and identical Rayleigh distribution (i.i.d),  $\delta(\cdot)$  represents the impulse function and  $\tau_n$  represents the delay of the  $n^{th}$  arriving path.

Applying this to multiple antenna arrays case as in figure 1, this makes the channel matrix to be  $KM_R \times NM_T$  a matrix.

$$H = \begin{pmatrix} h_1^1 & h_1^2 & \dots & h_1^{M_T} \\ h_2^1 & h_2^2 & \dots & h_2^{M_T} \\ \vdots & \vdots & \dots & \vdots \\ h_{M_R}^1 & h_{M_R}^2 & \dots & h_{M_R}^{M_T} \end{pmatrix}_{KM_R \times NM_T} \tag{3}$$

Where  $h_1^j$  is channel fading vector from  $j^{th}$  the antenna array at the transmitter to  $i^{th}$  antenna array at the receiver.

$$h_i^j = \begin{pmatrix} h_{i,1}^{j,1} & h_{i,2}^{j,1} & \dots & h_{i,K}^{j,1} \\ h_{i,1}^{j,2} & h_{i,2}^{j,2} & \dots & h_{i,K}^{j,2} \\ \vdots & \vdots & \dots & \vdots \\ h_{i,1}^{j,N} & h_{i,2}^{j,N} & \dots & h_{i,K}^{j,N} \end{pmatrix}_{K \times N} \tag{4}$$

At the transmitter, the transmit signal split into  $M_T$  parallel signals  $S_1(n), S_2(n) \dots S_{M_T}(n)$  through the splitter (demultiplexer) and is sent to the different antenna array to perform beamforming, thus the transmit signal becomes:

$$\widehat{S}_j(n) = W_j S(n) \tag{5}$$

Where  $W_j$  is the transmit beamforming weight vector and is given as:

$$W_j = [a_T(\theta_j)]^* \tag{6}$$

$$a_T(\theta_j) = [1, e^{-j2\pi d_1 \sin \theta_j / \lambda}, \dots, e^{-j2\pi(N-1)d_1 \sin \theta_j / \lambda}]^T \tag{7}$$

Where  $\theta_j$  is the angle of departure (AOD),  $d_i$  is the distance between the antenna element at  $j^{th}$  transmitter antenna array,  $\lambda$  is the carrier wavelength, N is the number of element at the  $j^{th}$  transmitter antenna array and  $a_T(\theta_j)$  is the transmit array steering response. After

beamforming,  $s(n)$  becomes  $N \times 1$  column vector  $\hat{s}_j(n)$ . At the receiver side, the receive signal at  $i^{th}$  array element is denoted as vector  $X(n)$  and is given as:

$$X_j(n) = HW_j S(n) \tag{8}$$

The receive beamforming is then weighted on  $X(n)$  and the output signal after beamforming at the  $i^{th}$  receive element antenna array is given as:

$$r_i(t) = \sum_{j=1}^{M_T} Z_i^H (X_j(n) + g_i(n)) \tag{9}$$

$$r_i(t) = \sum_{j=1}^{M_T} Z_i^H H \hat{S}_j(n) + Z_i^H g_i(n) \tag{10}$$

Where  $Z_i$  is the received beamforming weight vector and is given as:

$$Z_i = [a_R \theta_i] \tag{11}$$

$$a_R(\theta_i) = [1, e^{-j2\pi d_r \sin \theta_j / \lambda}, \dots, e^{-j2\pi (K-1) d_r \sin \theta_j / \lambda}] \tag{12}$$

Where  $\theta_i$  is the AOA (Angle of Arrival),  $d_r$  is the distance between the antenna element at  $i^{th}$  transmitter array,  $\lambda$  is the carrier wavelength,  $K$  is the number of element at the  $i^{th}$  receiver antenna array and  $a_R(\theta_i)$  is the receive array steering response.

$$r_i(n) = \sum_{j=1}^{M_T} Z_i^H H \hat{S}_j(n) + \eta_i(n) \tag{13}$$

Where  $\eta_i(n)$  spatially uncorrelated complex Gaussian noise with entry is distributed as  $\sim CN(0, N_o)$  and is given as:

$$\eta_i(n) = Z_i^H g_i(n) \tag{14}$$

Since,  $\hat{S}_j(n) = W_j S_j(n)$  we then substitute for  $\hat{S}_j(n)$  in the Equation (13).

$$r_i(t) = Z_i^H h_i^1(n) W_1 S_1(n) + \dots + Z_i^H h_i^{M_T}(n) W_{M_T} S_{M_T}(n) + \eta_i(n) \tag{15}$$

In matrix form:

$$\begin{bmatrix} r_1 \\ r_2 \\ \vdots \\ r_{M_T} \end{bmatrix} = \begin{bmatrix} Z_1^H h_1^1 W_1 & Z_1^H h_1^2 W_2 \dots & Z_1^H h_1^{M_T} W_{M_T} \\ Z_2^H h_2^1 W_1 & Z_2^H h_2^2 W_2 \dots & Z_2^H h_2^{M_T} W_{M_T} \\ \vdots & \vdots & \dots \\ Z_{M_R}^H h_{M_R}^1 W_1 & Z_{M_R}^H h_{M_R}^2 W_2 \dots & Z_{M_R}^H h_{M_R}^{M_T} W_{M_T} \end{bmatrix} \begin{bmatrix} S_1(n) \\ S_2(n) \\ \vdots \\ S_{M_T}(n) \end{bmatrix} + \begin{bmatrix} \eta_1 \\ \eta_2 \\ \vdots \\ \eta_{M_T} \end{bmatrix} \tag{16}$$

$$r = \bar{H} S + \eta \quad (17)$$

Where  $\bar{H}$  is effective channel matrix and is defined as:

$$\bar{H} = \begin{bmatrix} Z_1^H h_1^1 W_1 & Z_1^H h_1^2 W_2 \dots\dots\dots & Z_1^H h_1^{M_T} W_{M_T} \\ Z_2^H h_2^1 W_2 & Z_2^H h_2^2 W_2 \dots\dots\dots & Z_2^H h_2^{M_T} W_{M_T} \\ \vdots & \vdots & \dots\dots\dots \\ Z_{M_R}^H h_{M_R}^1 W_1 & Z_{M_R}^H h_{M_R}^2 W_2 \dots\dots\dots & Z_{M_R}^H h_{M_R}^{M_T} W_{M_T} \end{bmatrix} \quad (18)$$

This shows that the channel matrix consists of MIMO channel fading and information concerning AOD and AOA. As a result,  $\bar{H}$  is then transformed from a  $KM_R \times NM_T$  channel matrix to a  $M_R \times M_T$  channel matrix H. Due to the strong spatial correlation existing in each antenna array, according to the fading of the first element for each antenna array, the entire steering response of the antenna array is [12]:

$$h_i^j(\tau, t) = \sum_{i=0}^{L-1} [a_R \theta_i] \beta_{i,j}(t) [a_T \theta_j]^T \delta(\tau - \tau_n) \quad (19)$$

Where the channel fading vector  $h_i^j$  is a matrix of  $K \times N$  according to Equation (4),  $\beta_{i,j}(t)$  is the multipath fading components coupling the first element of the  $j^{th}$  antenna array at the transmitter to the  $i^{th}$  antenna array at the receiver and it obeys independent and identically Rayleigh-distribution (i.i.d).

Since the channel is assumed to be flat, Equation (17) becomes:

$$h_i^j(t) = [a_R \theta_i] \beta_{i,j}(t) [a_T \theta_j]^T \quad (20)$$

Then, the effective channel fading element  $\bar{H}_{i,j}$  can be roughly obtained as:

$$\bar{H}_{i,j} = [a_R \theta_i]^H [a_R \theta_i] \beta_{i,j} [a_T \theta_j]^T [a_T \theta_j]^* \quad (21)$$

Since  $\|a_R \theta_i\| = \sqrt{K}$  and  $\|a_T \theta_j\| = \sqrt{N}$

Where  $\|\cdot\|$  is the Euclidean Vector Norm, thus the effective channel fading element  $\bar{H}_{i,j}$  can be approximately obtained as:

$$\bar{H}_{i,j} = KN \cdot \beta_{i,j} \quad (22)$$

Therefore, the corresponding entire channel matrix can be formed as:

$$\bar{H} = KN \cdot \begin{bmatrix} \beta_{1,1} & \beta_{1,2} & \dots\dots\dots & \beta_{1,M_T} \\ \beta_{2,1} & \beta_{2,2} & \dots\dots\dots & \beta_{2,M_T} \\ \vdots & \vdots & \dots\dots\dots & \dots\dots \\ \beta_{M_R,1} & \beta_{M_R,2} & \dots\dots\dots & \beta_{M_R,M_T} \end{bmatrix} \quad (23)$$

Since the element of  $\beta_{i,j}$  and  $h_{i,j}$  has the same distribution (i.i.d), then the effective channel matrix in Equation (16) becomes:

$$\bar{\mathbf{H}} = \mathbf{K}\mathbf{N}.\mathbf{H} \quad (24)$$

To detect the transmit signal  $S(n)$ , Zero forcing (ZF) and Minimum Mean Square Error (MMSE) detection algorithm were considered and the receiver was design using the linear matrix  $\mathbf{G}$  according to certain algorithm. Thus, the receive signal is:

$$r(n) = \bar{\mathbf{H}}S + \eta \quad (25)$$

The detected signal is:

$$\hat{S} = \mathbf{G}r \quad (26)$$

$$\hat{S} = \mathbf{G}\bar{\mathbf{H}}S + \mathbf{G}\eta \quad (27)$$

For ZF detection algorithm:

$$\mathbf{G}_{ZF} = (\bar{\mathbf{H}}^H \bar{\mathbf{H}})^{-1} \bar{\mathbf{H}}^H \quad (28)$$

For MMSE detection algorithm:

$$\mathbf{G}_{MMSE} = [\bar{\mathbf{H}}^H \bar{\mathbf{H}} + \frac{\mathbf{I}_{KM_R}}{\gamma_o}]^{-1} \bar{\mathbf{H}}^H \quad (29)$$

If the system uses ZF or MMSE detection algorithm, the effective detection SNR of the  $q^{th}$  data streams with linear ZF or MMSE equalizer at the receiver is expressed as [13, 14]:

$$\gamma_q^{ZF+Bf} = \frac{\gamma_o}{(\bar{\mathbf{H}}^H \bar{\mathbf{H}})^{-1}_{q,q}} ; q = 1, 2, \dots, M_T \quad (30)$$

$$\gamma_q^{MMSE+Bf} = \frac{\gamma_o}{[\bar{\mathbf{H}}^H \bar{\mathbf{H}} + \frac{\mathbf{I}_{KM_R}}{\gamma_o}]^{-1}_{q,q}} - 1 ; q = 1, 2, \dots, M_T \quad (31)$$

Where  $\gamma_o$  is the average SNR at each receiver antenna array and is obtained as:

$$\gamma_o = \frac{P_q}{KN_o} \quad (32)$$

Where  $P_q$  is the transmit power at each  $j^{th}$  transmit antenna array.

If the transmit power is equally allocated across the transmit antenna array,

$$P_q = \frac{P_o}{M_T N} \quad (33)$$

Then,

$$\gamma_o = \frac{P_o}{M_T K N N_o} \quad (34)$$

Where  $P_o$  is the total transmitted power.

By substituting for  $\gamma_o$  in the Equation (29) and (30),

$$\gamma_q^{ZF+Bf} = \frac{P_o}{\left(\bar{H}^H \bar{H}\right)_{q,q}^{-1} K N N_o M_T} \quad ; q = 1, 2, \dots, M_T \quad (35)$$

$$\gamma_q^{MMSE+BF} = \frac{P_o}{M_T K N N_o \left[ \bar{H}^H \bar{H} + \frac{I_{KM_R}}{\gamma_o} \right]_{q,q}^{-1}}^{-1} \quad ; q = 1, 2, \dots, M_T \quad (36)$$

According to Equation (24), Equation (35) and (36) become:

$$\gamma_q^{ZF+Bf} = \frac{P_o N K}{(H^H H)_{q,q}^{-1} N_o M_T} \quad ; q = 1, 2, \dots, M_T \quad (37)$$

$$\gamma_q^{MMSE+BF} = \frac{P_o}{M_T K N N_o \left[ (H^H H) K^2 N^2 + \frac{M_T K N N_o I_{KM_R}}{P_o} \right]_{q,q}^{-1}}^{-1} \quad ; q = 1, 2, \dots, M_T \quad (38)$$

Thus, the system capacity for wireless system is given by [14, 15]:

$$C = \sum_{q=1}^{N M_T} \log_2 (1 + \gamma_q) \quad (39)$$

The system capacity for the hybrid scheme when ZF and MMSE were adopted as receiver is obtained as:

$$C_{ZF+Bf} = \sum_{q=1}^{N M_T} \log_2 \left( 1 + \frac{P_o N K}{(H^H H)_{q,q}^{-1} N_o M_T} \right) \quad (40)$$

$$C_{MMSE+BF} = \sum_{q=1}^{N M_T} \log_2 \left( \frac{P_o}{M_T K N N_o \left[ (H^H H) K^2 N^2 + \frac{M_T K N N_o I_{KM_R}}{P_o} \right]_{q,q}^{-1}} \right) \quad (41)$$

#### 4. Simulation Results

This paper provides the simulation results of the proposed hybrid MIMO technique for high data rate wireless communication system. The performance metrics in terms of spectral efficiency and BER of Conventional MIMO, Spatial Multiplexing scheme and the Beamforming scheme are given to compare with the proposed hybrid technique. The transmitter and the receiver are assumed to have 2 smart antenna arrays at both ends and we examine N and K to be equal to 2, 4 and 8 elements in each array. The spacing between antenna arrays is larger than  $10\lambda$ , while the spacing between antenna elements is  $\lambda/2$ . The angle spread at each of the transmitter antenna array is 30 degrees and 70 degrees at the receiver side. The channel has the Rayleigh fading distribution, and spatially uncorrelated complex Gaussian noise is added to the faded signal at the receiver. 16-QAM modulations are used to modulate the symbols at the

transmitter and ZF and MMSE detection are adopted at the receiver for the entire schemes. These detections are further enhanced by linear nulling and successive interference cancellation algorithm called Vertical- Bell-Labs Layered Space-Time Architecture (V-BLAST) to achieve better performance.

Spectral efficiency is the capacity of the system which shows the amount of maximum information that can be sent by a wireless communication system. Conventionally, this can be increased by the factor of  $\min\{M_R, M_T\}$  without using additional transmits power or spectral bandwidth. This paper shows that maximum spectral efficiency is achievable by increasing the number of element in each antenna array at both ends of radio link.

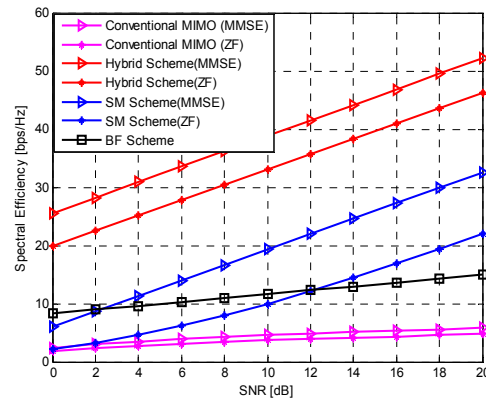

Figure 2. Spectral Efficiency for the Proposed Wireless MIMO System when  $M_T = 2$ ,  $M_R = 2$ ,  $K=2$  and  $N=2$

Figure 2 shows the spectral efficiency performance of the proposed system with ZF and MMSE detection when  $M_T = 2$ ,  $M_R = 2$ ,  $K=2$  and  $N=2$ . This result indicates that the hybrid scheme has the best performance with average spectral efficiency of 38.86b/s/Hz when MMSE was considered as detection and 33.08b/s/Hz for ZF detection than spatial multiplexing scheme with the average spectral efficiency of 21.73b/s/Hz and 14.24b/s/Hz for MMSE and ZF detection respectively; and beamforming scheme with the average spectral efficiency of 11.62b/s/Hz. The result further shows that the Conventional MIMO system with  $M_T = 2$  and  $M_R = 2$  has an average spectral efficiency of 4.38b/s/Hz when MMSE detection was used and 3.54b/s/Hz for ZF detection which obviously indicate that the Conventional MIMO scheme has a poor capacity performance compared to the other scheme. Thus, this proves that spatial multiplexing technique can be used to achieved high data rate than beamforming technique and it further shows that hybrid scheme make use of the advantages of both technique to produce higher spectral efficiency.

Figure 3 shows the average error produce by the proposed techniques when  $M_T = 2$ ,  $M_R = 2$ ,  $K=2$  and  $N=2$ . It is clear that MMSE detection performed better than the ZF detection in the entire scheme. The result shows that spatial multiplexing scheme performs better at lower SNR while beamforming scheme perform better at high SNR. This limitation of the two schemes was compensated for with hybrid scheme. Thus, hybrid scheme has good BER performance and will provide an average error of 0.0017 for MMSE detection and 0.0024 for ZF detection. The result also shows that beamforming scheme only performs better than hybrid scheme at high SNR of 14dB, but it will provide a high average error of 0.0326 than hybrid scheme. It is also clear from the result that conventional MIMO have a poor performance among the entire scheme.



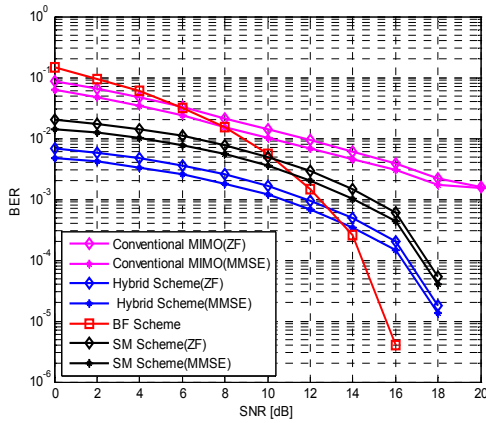

Figure 3. BER Performance when  $N=2$  and  $K=2$

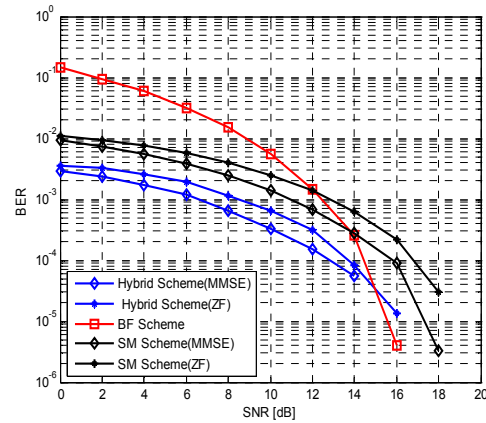

Figure 4. BER Performance when  $N=2$  and  $K=2$  for V-BLAST

The performance of the system was further enhanced by V-BLAST algorithm as shown in the result produced in Figure 4. V-BLAST improves the performance of MMSE and ZF detection in the entire schemes. The hybrid scheme outperforms other schemes with MMSE detection having a better average BER of 0.000865 and ZF detection with an average BER of 0.0012. This proves that hybrid scheme has improved in performance in terms of error reduction by 49.6% and 50% for MMSE and ZF detection respectively with the aid of V-BLAST.

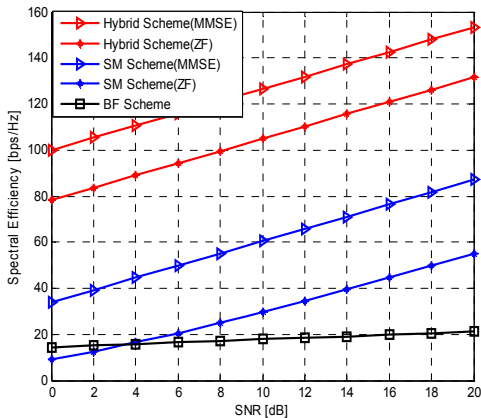

Figure 5. Spectral Efficiency for the Proposed Wireless MIMO System when  $M_T = 2$ ,  $M_R = 2$ ,  $K=4$  and  $N=4$

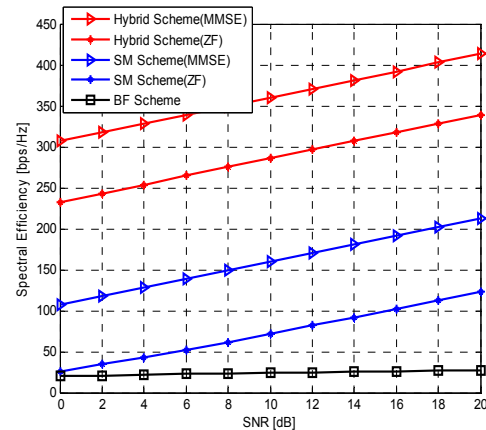

Figure 6. Spectral Efficiency of the Proposed Wireless MIMO System  $M_T = 2$ ,  $M_R = 2$ ,  $K=8$  and  $N=8$

Figure 5 shows that the spectral efficiency of the system increases linear with the number of element in each antenna array. With the  $M_R$  and  $M_T$  antenna arrays remain constant and element  $K$  and  $N$  were increased from two to four, the simulation result shows that the capacity performance of hybrid scheme is better than individual scheme and it will provide an average spectral efficiency of 126.59b/s/Hz when MMSE detection is used and 104.93b/s/Hz for ZF detection. This shows that hybrid scheme has an increment of 87.73b/s/Hz for MMSE detection and 71.87b/s/Hz for ZF detection when the antenna array element was increased. This was further proved by increasing  $K$  and  $N$  to eight elements as the result was given in Figure 6. The hybrid scheme has an average spectral efficiency of 360.11b/s/Hz and

285.78b/s/Hz for MMSE and ZF detection respectively than other scheme. Thus, this proves that the capacity of MIMO system can be enhanced by increasing the number of antenna element in each array at the transmitter and receiver.

Similarly, Figure 6 shows the BER performance of the system; when  $N$  and  $K$  were increased from 2 to 4 while the antenna array  $M_R$  and  $M_T$  remains constant. The result proves that the increase in the antenna array element  $N$  and  $K$  produced better system performance. It was shown that hybrid scheme has a better BER performance with average error of 0.000434 for MMSE detection and 0.000297 for ZF detection than any of the schemes. This shows a significant improvement in BER compare to when  $N$  and  $K$  equal to 2 and when the system was enhanced with V-BLAST as in figure 3 and 4 respectively. Figure 8 shows the enhancement of the system in this case with V-BLAST and better performance of hybrid scheme was recorded with an average BER of 0.0000719 and 0.000202 for MMSE and ZF detection respectively.

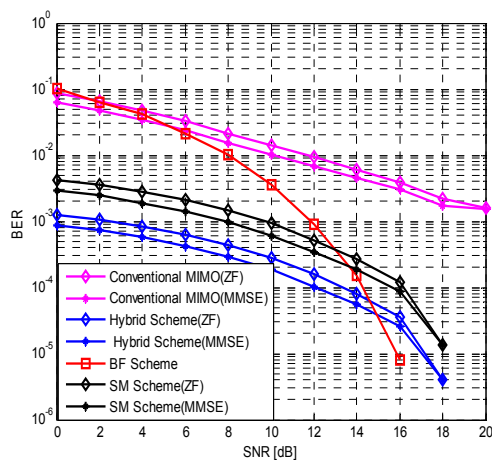

Figure 6. BER Performance when  $N=4$  and  $K=4$

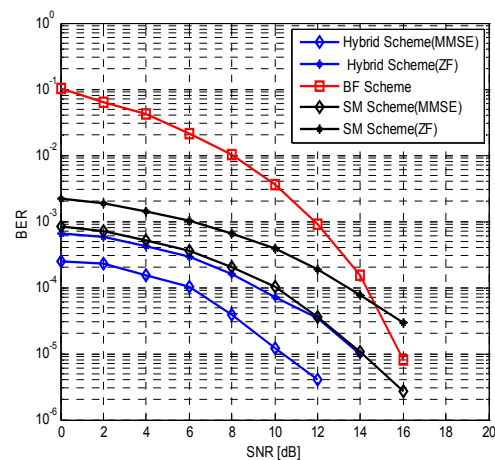

Figure 7. BER Performance when  $N=4$  and  $K=4$  for V-BLAST

## 5. Conclusion

The performance analysis of a hybrid MIMO technique was proposed for high data rate wireless communication system in this paper. This scheme involves the combination of spatial multiplexing and beamforming technique and was used as a transmission scheme which makes the system to be able to transmit parallel data streams as well as obtaining beamforming gain. The MMSE and ZF MIMO detection algorithm was employed at the receiver and was further enhanced by V-BLAST. Spectral efficiency and BER were the two performance metrics used to determine the efficiency of the schemes. The simulation results show that the hybrid scheme outperforms the individual spatial multiplexing and beamforming scheme; and each of the schemes is better than the Conventional MIMO scheme. It was found that the higher the antenna array element the higher the system spectral efficiency and the better the system reliability. The results also show that the MMSE detection has a better performance in all the schemes than the ZF detection and even when enhanced by V-BLAST.

## References

- [1] Proakis JG. Digital Communications. 4th ed. New York: McGraw-Hill, 2001.
- [2] Shannon CE. A mathematical theory of communication – Part I & II. *Bell Syst. Tech. J.*, 1948 27: 379–423.
- [3] Foschini GJ. Layered space-time architecture for wireless communication in a fading environment when using multi-element antennas. *Bell Labs Tech J.*, 1996; 1(2): 41–59.
- [4] Gans G, Gans MJ. On the limits of wireless communications in a fading environment when using multiple antennas. *Wireless Personal Communications*. 1998; 6(3): 311–355.

- 
- [5] Jan M, Robert S, Lutz L, Wolfgang HG, Peter AH. Multiple-Antenna Techniques for Wireless Communications – A Comprehensive Literature Survey. *IEEE Communications Surveys & Tutorials*. 2009; 11(2): 87-105.
- [6] Ian FA, David MG, Elias C. The evolution to 4G cellular systems: LTE-Advanced. *ScienceDirect Physical Communication*. 2010; 3: 217–244.
- [7] George J, Mikael S, Björn O. Combining Beamforming and Orthogonal Space - Time Block Coding. *IEEE Transactions on Information Theory*. 2002; 48(3).
- [8] Li Ping, Linrang Zhang, So HC. On a Hybrid Beamforming/Space-Time Coding Scheme. *IEEE Communications Letters*. 2004; 8(1).
- [9] Wang Y, Liao GS. *Combined Beamforming with Alamouti Coding Using Double Antenna Array Groups for Multiuser Interference Cancellation*. Progress in Electromagnetics Research, PIER. 2008; 88: 213–226.
- [10] Zhu F, Lim MS. Combined beamforming with space-time block coding using double antenna array group. *Electronics Letters*. 2004; 40(13): 811-813.
- [11] Gore D, Health Jr Rw, Paularj A. Transmit Selection in spatial Multiplexing system. *IEEE communication Letter*. 2002; 6(11): 491-493.
- [12] Akbar MS. Deconstructing Multiantenna Fading Channels. *IEEE Transactions on Signal Processing*. 2002; 10.
- [13] Aris LM, Raj Kumar K, Giuseppe C. *Performance of MMSE MIMO Receivers: A Large N Analysis for Correlated Channels*. IEEE Vehicular Technology Conference. 2009; 1-5.
- [14] Fochini G, Gans M. On limits of wireless communications in a fading environment when using multiple antennas. *Wireless personal communications*. 1998; 6-3: 311-335.
- [15] E Telatar. Capacity of mult-antenna Gaussian channels. *European Transactions on Telecommunication Related Technologies*. 1999; 10: 585-595.