

Fog computing in classrooms: boosting efficiency, responsiveness, user experience

Tasrif Hasanuddin^{1,2}, Mokh Sholihul Hadi¹, Sujito¹, Rosnani³

¹Department of Electrical Engineering and Informatics, Universitas Negeri Malang, Malang, Indonesia

²Department of Computer Science, Universitas Muslim Indonesia, Makassar, Indonesia

³Department of Information System, STMIK Professional Makassar, Makassar, Indonesia

Article Info

Article history:

Received Jan 31, 2024

Revised Apr 6, 2024

Accepted Apr 13, 2024

Keywords:

Cloud computing

Fog computing

Fog-centric infrastructure

Modern classroom

Smart class

ABSTRACT

In the context of rapidly advancing smart education systems, the effective management and optimization of modern classroom remain critical challenges. This research presents a novel methodology leveraging cloud and fog computing-based simulations, with a specific focus on the implementation of iFogSim. Empirical findings validate the efficacy of fog computing in monitoring classrooms, demonstrating significant improvements in performance metrics compared to traditional cloud computing architectures. Specifically, fog computing ensures remarkably low latency, with a mere 7 milliseconds, even with scalable integration across multiple classrooms. In contrast, cloud computing infrastructures exhibit considerably higher initial latencies, starting at 210 milliseconds, which further escalate with the increasing number of monitored classrooms. Furthermore, our analysis reveals substantially lower network overhead associated with fog computing, measuring at 5,231.8 kilobytes, in sharp contrast to the significantly higher network usage of 80,808 kilobytes observed with cloud computing solutions. These findings underscore the potential of fog computing as a promising solution for efficient and real-time management classroom in smart education environments.

This is an open access article under the [CC BY-SA](#) license.



Corresponding Author:

Mokh Sholihul Hadi

Department of Electrical Engineering and Informatics, Universitas Negeri Malang

Malang, Indonesia

Email: mokh.sholihul.ft@um.ac.id

1. INTRODUCTION

Swift advancements in technology have found application across diverse aspects of our lives. The adoption of technology serves to minimize energy consumption and time inefficiencies associated with traditional approaches. Among the cutting-edge technological trends today is the prevalence of the internet of things (IoT) [1]. The integration of IoT technology into the learning process has ushered in a transformative period in the realm of education, facilitated by the implementation of modern classrooms. Universities and colleges are increasingly acknowledging the crucial role of initiatives aimed at enhancing the learning quality facilitated by educators and students with the integration of information technology [2]. Digital advancements in education [3], [4] serve as guiding principles for contemporary pedagogical methods that foster students' cognitive development [5]. This research focused on developing a novel smart framework intended for use in online education. The primary objective of this smart framework was to empower users in accessing online learning resources tailored to their individual abilities. Artificial intelligence (AI) was utilized to categorize user capabilities. The classification of user abilities through AI aimed to ensure the delivery of materials aligned with the user's proficiency level [6]. Survey data indicate that students are

receptive to modern classroom services, partly due to their supportive attitude towards the integration of innovative teaching and learning technologies [7].

Modern classroom technology stands as an innovative educational platform, acting as a bridge between the virtual and physical worlds, thereby fostering hyper learning experiences [8]. This technology not only facilitates active participation and collaboration but also empowers students to engage in classroom activities utilizing the diverse capabilities of IoT technology [9]. In the pursuit of effective educational processes, a platform-centered learning approach has been employed to empower lecturers with control over various facets of the educational process, including task management, verification, activity monitoring, and student performance assessment [10]. Utilizing cameras to monitor the condition of classrooms has proven to be an efficient method for enhancing the quality of education [11]. This approach generates substantial real-time data, which is subsequently stored in a server database. However, notwithstanding the progress made in smart class systems integrating cutting-edge technologies, achieving widespread adoption continues to pose a challenge. One potential obstacle to their broad acceptance is the high latency rate and network usage intrinsic to existing cloud-based implementations. For example, in [12], participants in a recent study pointed out a deficiency in video communication, restricted one-on-one interaction, and problems with sound synchronization as further difficulties encountered during synchronous courses.

We introduce the fog-based smart class architecture (FBSCA) in this paper, which constitutes a novel approach to enhance the efficiency and effectiveness of smart class systems. The contributions of this research are outlined as follows:

- A three-tiered architecture is proposed for the smart class system, leveraging fog computing at the intermediary tier. This architecture employs intelligent cameras to capture and record specialized events within the classroom environment. Notably, intelligent cameras necessitate reduced storage capacity for storing recorded footage. Raw video data is processed at the fog node instead of being transmitted to the cloud, thereby circumventing the transfer of massive data volumes to the data center. The fog node undertakes tasks related to object detection and tracking, while the intelligent cameras autonomously handle functions such as classroom detection and camera feedback operations. Additionally, the fog node is responsible for tasks including alert generation and result display.
- The FBSCA takes into account factors such as latency and network usage, aiming to minimize their impact. Through careful design considerations, latency and network usage are effectively mitigated.
- Extensive simulations are conducted to assess the performance of the proposed FBSCA. Experimental evaluations reveal a notable reduction in latency and network usage when compared to cloud-based implementations of smart class systems.

The proposed framework is implemented in the iFogSim simulator [13]. We conducted a comparative analysis between the proposed fog computing-based smart class and the cloud computing-based smart class. This proposed framework demonstrates a significant improvement in several parameters such as latency and network utilization.

2. METHOD

2.1. Fog computing and IoT

The evolution of the IoT alongside fog computing infrastructure introduces a novel concept known as the smart home. Innovations within the smart home sector serve the purpose of regulating the usage of electronic devices and implementing security automation through hardware control [14]. The progress in communication technology has led to advancements in various aspects. For instance, the internet is now employed in the control system of traffic lights, allowing for adjustments based on specific settings and real-time monitoring. As communication technology continues to evolve, the concept of the IoT has emerged, aiming to extend the advantages of internet communication systems to influence other interconnected systems [15]. This scientific inquiry elucidates the inherent advantages of fog computing, particularly in its capacity to perform processing tasks locally, thereby reducing reliance on distant cloud servers [16]. By minimizing latency and mitigating the challenges associated with traditional cloud computing networks, fog computing emerges as an effective solution [17]. The investigation not only tackles processing delays but also enhances the utilization of network resources, there by fostering a more responsive and efficient network environment [18].

The research aligns with prevailing trends in fog-based architectures, emphasizing the optimization of resource utilization, enhanced security, and cost-effective solutions [19]. Fog computing augments network efficiency, resulting in an improved user experience by creating a smarter and more responsive network environment [20]. Notably, this approach significantly diminishes overall network traffic, a critical advantage in the burgeoning IoT framework [21]. In the IoT landscape, characterized by devices requiring real-time data exchange, fog computing emerges as an optimal solution [22]. By curbing network traffic,

real-time data can be exchanged swiftly and efficiently, ensuring seamless user experiences [23]. Moreover, fog nodes extend beyond mere data storage and processing; they facilitate device interaction within the IoT ecosystem, enable real-time data analysis, and facilitate swift decision-making at the network's edge [24]. Far from being mere technological infrastructure, fog nodes serve as pillars supporting the digital civilization of the future, driving innovation, and imparting tangible benefits to diverse facets of our lives [25].

2.2. Proposed framework

This article proposes a modern classroom system based on fog computing and compares it with cloud computing across several parameters. We carried out an examination on a surveillance system, utilizing an application module placement algorithm implemented on both fog node servers and the cloud, considering their computing capabilities. In the module placement algorithm to achieve appropriate latency, the complete task is divided into several modules. Some tasks involve determining whether the module should be placed on a fog node server. Figure 1 illustrates the architecture of a modern classroom in a fog computing environment. It is a three-tier architecture, with the top layer containing the cloud data center. The middle layer comprises fog nodes. The bottom layer consists of all devices (sensors and actuators) referred to as the device layer. Cameras generate video streams and upload them to the fog node server for video analysis. The cloud is utilized for storing video recordings for future use. In Figure 1, there are several classrooms, each equipped with 2 surveillance cameras and one fog node server. The proposed model is depicted in Figure 1. This framework comprises three modules: classroom space detection, object tracking within the classroom, and decision-making, all of which are necessary for simulation purposes.

While cloud computing excels in managing and monitoring data over extended periods, frequent reliance on the cloud for data transmission can lead to increased delays and network resource utilization. These undesirable consequences can adversely impact the performance of concurrently running programs. To mitigate these challenges, an intermediary layer, known as the fog node server, is integrated, substantially reducing delays. This reduction is achieved by minimizing the need to send video streams to the cloud for frequent analysis and data retrieval related to classroom conditions. Operations performed in the cloud typically take longer than in the fog. In the proposed architecture, a two-way communication channel is established between the fog node and the cloud. video processing and storage predominantly occur at the fog node level, with periodic data transmission to the cloud for long-term storage. This research explores the efficiency benefits derived from this fog-to-cloud integration, providing valuable insights for optimizing data management and real-time operations in modern educational settings.

This scientific paper explores the innovative architectural paradigm of fog-based architecture, a recent concept that integrates multiple devices such as cameras, Raspberry Pi, fog points, gateways, and a centralized cloud server. Within this architectural framework, cameras play a pivotal role by recording the classroom environment in real-time. Each time a student occupies a seat upon entering the classroom, the associated intelligent cameras record specialized event, which is then processed on a fog node server situated at the fog point. Subsequently, a processed video depicting the 'classroom condition,' including the student, is relayed to the modern classroom management system residing within fog nodes.

To ensure comprehensive classroom monitoring, two strategically positioned cameras are employed in each classroom, record all specialized events from seating positions. The Raspberry Pi plays a vital role in this architecture, facilitating seamless communication between the cameras and the fog spots. This paper provides an in-depth exploration of the integration and functionality of camera-centric systems within the context of fog-based architectures, shedding light on the mechanisms driving efficient classroom monitoring solutions. This scientific paper investigates the integration of fog-based architecture with cloud computing in the context of modern educational environments. Within this framework, fog nodes establish connections with a central cloud server, transmitting data acquired through strategic placement of fog points within each faculty. Each faculty incorporates at least one fog point into the modern class management system, enabling the processing, and transmission. The cloud-based modern classroom management system serves as a repository for this information, acting as a reference point for future analysis and goal-setting.

This scientific paper presents an advanced fog-centric classroom architecture for each faculty, depicted in Figure 1. Figure 2 shows fog node configuration, while Figure 2(a) showcases a single classroom scenario with strategically placed fog nodes enabling efficient data transmission to the cloud for long-term storage. In contrast, Figure 2(b) demonstrates a multi-classroom configuration, where each faculty is equipped with its own fog spot, interconnected with a centralized cloud server. This setting ensures stable network delay and fog node consumption while potentially increasing the time and network resources required for data upload and retrieval from the central cloud server.

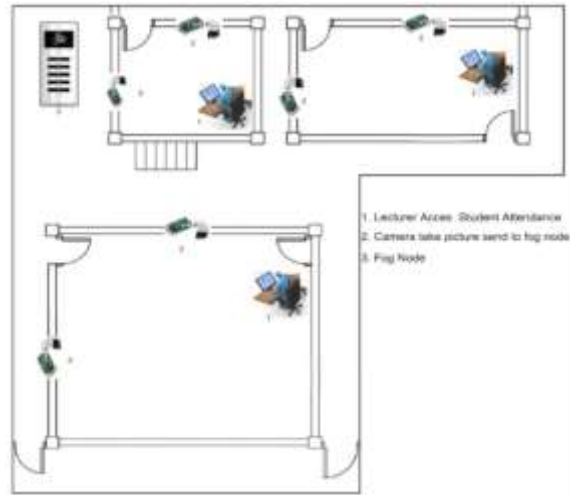
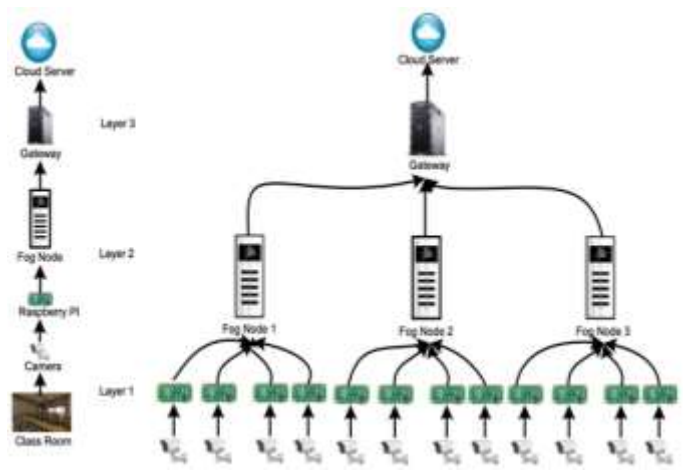
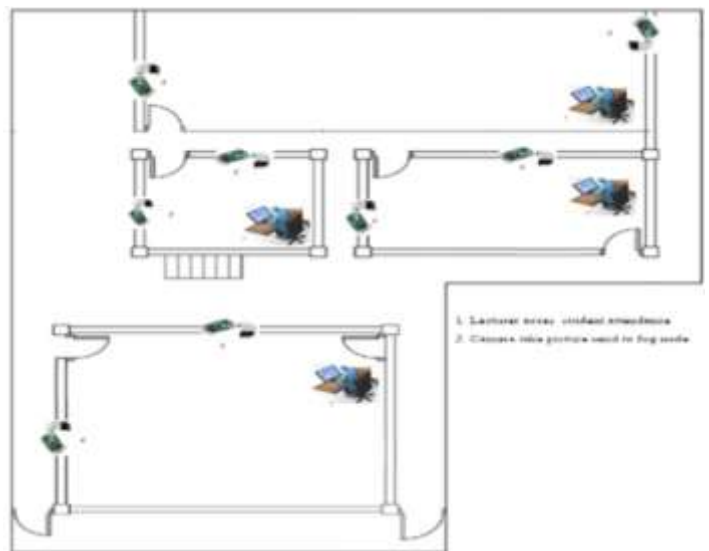

Figure 1. Modern class using fog node and cameras



(a)



(b)

Figure 2. Fog node configuration (a) single class room and (b) multiple class room

Exploring the components of the proposed architecture reveals key insights. The configuration of fog nodes in a classroom setting is crucial for optimizing data handling and processing speed. Each node is strategically integrated to support real-time educational applications and analytics. Delving into the components of the proposed architecture.

2.2.1. Cameras

The fundamental component of contemporary classroom systems is the camera layer, which is pivotal in capturing visual data for the comparative analysis between fog and cloud infrastructure networks. This layer utilizes high-definition cameras to record video data. The resulting audio is subsequently transmitted to a fog node server for detailed analysis.

2.2.2. Fog nodes

Fog nodes act as intermediaries between cameras and cloud servers, processing video streams data using mid-range servers. Each class is assigned a unique identifier (e.g., “U_301” for “Class 301” on the 3rd floor of room 301). The modern class management system on the fog node updates data regularly, providing real-time information. Fog nodes serve as temporary data storage before transmission to the cloud, facilitating real-time processing and inspection at the edge.

2.2.3. Cloud layers

In this design, the cloud primarily stores image data after it is no longer needed by fog nodes. Gateways enable seamless data exchange between fog and cloud, ensuring data availability and update continuity. Fog nodes collaborate, allocating resources and exchanging critical information, enabling robust data storage and management. Notably, fog nodes have the capacity to store data independently, ensuring data persistence during gateway downtime. This comprehensive fog-cloud integrated architecture presents a sophisticated solution for managing modern classrooms, offering real-time data processing, robust storage, and enhanced reliability in diverse educational environments.

3. RESULTS AND DISCUSSION

The simulation carried out requires the use of a high-definition smart camera for video collection purposes at the classroom location. These videos are then sent to the fog point, where they are analyzed to classrooms status. After this analysis, the videos are then processed on modern class management systems located in the fog and in the cloud using a Wi-Fi connection. The establishment of relationships between fog nodes and cloud servers is facilitated by gateways. In our simulations, we use iFogSim, a custom tool designed specifically for IoT devices. Delay and network usage were evaluated using iFogSim, with variables set to represent classrooms and the number of fog spots, where each classroom has 2 cameras. The experimental configuration consisted of four different classrooms. Initially, 2 cameras were installed in each classroom area to take videos. A primary cloud device is implemented, where fog nodes establish a connection through a gateway. It is worth noting that each particular region in each faculty comes with its own unique fog node. The camera is emulated as a sensor, in line with specified policies, due to its smart features and its integration with the Raspberry Pi.

The number of classes was systematically increased step by step to assess the impact on various scenarios. To evaluate the impact of the number of class areas on network delay and utilization in fog nodes, we introduce more areas into a given configuration. Figure 2 presents the topology designed for the purpose of assessing fog-centric scenarios. The topology considered consists of one fog node, where each node is interconnected with at least two cameras located in 1 class area. The main objective of this research is to assess network delay and utilization in the iFogSim framework. Additionally, fog points transmit revised class status to the modern class system. As the number of classrooms increases, the distribution of fog spots also increases. Increasing the number of class areas placed in a given fog node results in a simultaneous increase in network delay and utilization. One of the significant benefits of this configuration is the reduced computing load on the cloud infrastructure, as most of the computing is done in the fog nodes. However, the act of connecting the camera, then the Raspberry Pi, and to the cloud server via the gateway results in increased delays and increased network bandwidth usage. Cloud server, gateway, and fog server configuration parameters during fog-centric simulations use standards provided by iFogSim. The parameters include factors such as processing capability, random access memory (RAM), uplink and downlink bandwidth, performance level, processing speed to cost ratio, and power consumption metrics. In the context of performance evaluation in a cloud-based environment, it is proven that many cameras are interconnected with cloud servers through the use of Raspberry Pi and gateways. The camera sends classroom visual data to a remote server located in the cloud, where the received videos are then analyzed and processed.

This section presents the results derived from the proposed fog-centric architecture, focusing specifically on metrics pertaining to network delays and utilization. Comparative analyses are conducted with findings obtained through cloud-based methodologies. The experimental outcomes underscore the superior performance of the fog-centric approach, particularly in terms of reduced delays and minimized network utilization when contrasted with cloud-based models. Table 1 provides a comprehensive breakdown of network delay and usage statistics observed within the fog environment, juxtaposed with results obtained from the cloud-based framework.

Table 1. Simulation results for the modern class architecture leveraging fog and cloud technologies

Number of classes	Fog delay (ms)	Cloud delay (ms)	Fog network usage (kb)	Cloud network usage (kb)
1	7.038571	210.1974192	5,231.8	80,808.4
2	7.038571	210.3836752	11,687.6	161,521.8
3	7.038571	210.5791015	16,409.4	242,235.2
4	7.038571	210.7766248	22,865.2	322,948.6
5	7.038571	210.26	29,525	403,662
6	7.038571	211.1738768	32,818.8	484,375.4
7	7.038571	211.3728351	38,866.6	564,888.8
8	7.038571	211.5721701	4,2058.4	645,402.2
9	7.038571	211.9709328	46,678.2	725,915.6
10	7.038571	211.9710134	5,6704	806,429
11	7.038571	212.1707695	63,057.8	886,942.4
12	7.038571	212.3701597	64,719.6	967,455.8
13	7.038571	247.795416	74,541.4	1,009,269.2
14	7.038571	310.8803952	75,591.2	1,012,382.6
15	7.038571	365.5686994	83,679	1,015,496
16	7.038571	413.3915468	91,868.8	1,018,609.4
17	7.038571	455.6011463	93,836.6	1,021,722.8
25	7.038571	671.7672221	136,507	1,046,630
33	7.038571	783.0507958	180,503.4	1,071,537.2
41	7.038571	851.0084865	228,885.8	1,096,444.4
50	7.038571	901.3414827	272,812	1,124,465

Network delay stands as a critical metric, especially in environments requiring instantaneous and high-end performance. One of the pivotal advantages of fog computing lies in its capacity to minimize frequent cloud access. This paradigm mandates the execution of computing at the network edge, ensuring rapid responses to client devices and significant reductions in delays. The computational analysis of visual representations from specific locations is transmitted to the fog spot, strategically positioned at the network's edge. Each fog spot is meticulously dedicated to a particular area. The delay computing mechanism is encapsulated in (1).

$$Delay = \alpha + \mu \quad (1)$$

Delay is represented by an equation involving two primary variables:

α : the time taken to fetch the video from the camera to the modern class management system.

μ : the time expended to transmit the video from the modern class management system to the user.

Network utilization emerges as a significant concern, especially amidst substantial increases in data volume directed towards cloud servers. In such scenarios, cloud resource utilization becomes pivotal. Persistent spikes in network traffic targeting cloud servers invariably lead to escalated network utilization, consequently slowing down data transmission speeds. To address this challenge, a well-structured configuration allocates specific fog nodes to each faculty, exclusively catering to requests originating from designated regions. This setup yields two primary outcomes: diminished network utilization and accelerated transmission speeds for the remaining data traffic. The results highlight the efficiency and potential of fog-centric architectures in optimizing network performance and data transmission in diverse real-time applications.

This research offers experimental observations regarding the effectiveness of modern fog-centric classroom architecture, exemplified in Figure 1. Table 1 provides a detailed analysis of diverse scenarios encompassing fog and cloud configurations, elucidating the setup variations involving cameras connected to fog points and cloud servers. The research utilizes a single fog node in its experimentation, examining scenarios ranging from 1 to 50 classrooms, with each point connected to 2 cameras. The observed trend of escalating classroom size remains consistent across all situations, emphasizing the scalability of the proposed architecture. The evaluation, conducted using iFogSim, focuses on assessing network delay, and utilization data.

In the fog-centric configuration, local processing capabilities of fog points enable specific video handling in designated areas. Conversely, cloud servers engage in processing videos from disparate regions, leading to increased delays as the number of cameras augments. Comparative analysis presented in Figures 3 shows comparative analysis of fog vs cloud in a smart classroom network, Figures 3(a) and 3(b) illustrates a pronounced correlation between the upsurge in classroom numbers and amplified cloud delays, underscoring the advantage of fog-centric architecture in mitigating delays.

Additionally, Figure 3(b) visualizes the network utilization results in the fog scenario, demonstrating an increase corresponding to the addition of fog points and cameras. This observed increment aligns with the growing prevalence of cloud computing, as data tuples are consolidated in a single cloud server, amplifying network requirements. Each fog node, in contrast, exclusively handles data originating from its designated camera, exemplifying the efficacy of fog-centric architectures in optimizing data processing and transmission.

This research explored how using cameras to monitor classrooms can improve education quality. Previous studies have examined how this generates real-time data stored in cloud servers, but haven't focused on its impact on latency and network usage, which are issues with current cloud-based systems. We discovered that a fog-centric approach, emphasizing local processing, reduces delays and network usage. Our method significantly favors this fog-centric approach over cloud-based models.

Our findings suggest that leveraging fog and edge devices doesn't compromise performance, unlike existing systems which struggle with simultaneous student-instructor interaction [26]. Our proposed method benefits from a streaming server ensuring uninterrupted communication. The results of our study underscore the potential of fog computing in revolutionizing classroom monitoring systems. By shifting processing tasks closer to the data source, our approach offers a more efficient and reliable solution compared to traditional cloud-based models. However, challenges remain, including the need for further refinement in object detection and tracking algorithms. Future research should focus on addressing these limitations to fully realize the potential of fog-centric classroom monitoring systems.

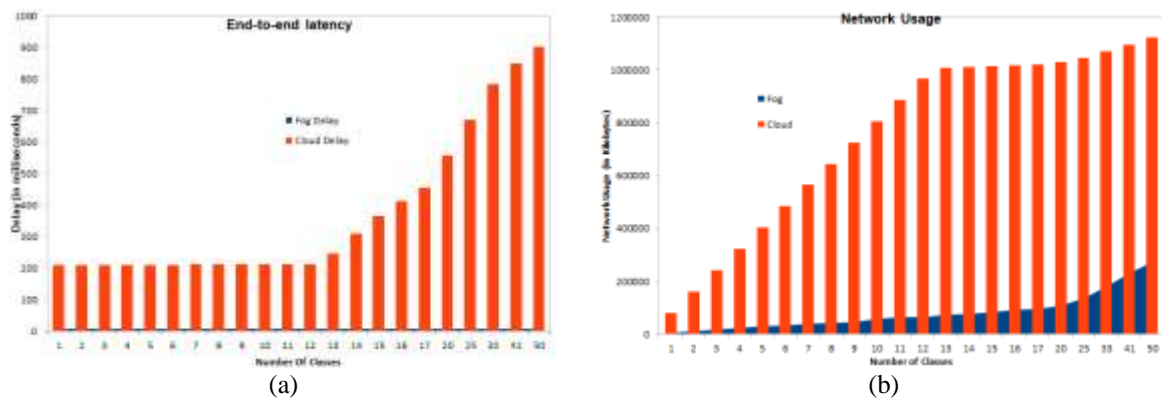

Figure 3. Comparative analysis, (a) end to end latency between fog cloud and (b) network usage between fog and cloud

4. CONCLUSION

Fog computing has emerged as a pivotal element in contemporary technology landscapes, particularly for applications necessitating swift responses. The proliferation of data-generating devices has accentuated the demand for rapid, efficient processing. Our proposed modern fog-based classroom design employs computer vision techniques, thereby enhancing resource allocation within classrooms. The empirical evidence provided in this research unequivocally showcases the superiority of fog-based strategies compared to cloud-based alternatives, notably in terms of diminished delays and reduced network requirements.





However, a notable limitation of our methodology lies in its dependence on cameras for classroom monitoring, potentially eliciting privacy concerns, especially concerning data storage on cloud platforms. Data privacy is a paramount concern in cloud-based data storage, notwithstanding the fact that the majority of storage and processing activities occur in nearby fog nodes. Future research endeavors may explore the integration of robust encryption algorithms as a viable solution to address these concerns effectively. Furthermore, as we delve into larger class areas, the implementation of efficient load balancing mechanisms at fog points becomes indispensable to sustain optimal performance. Our forthcoming efforts will be devoted

to exploring strategies for load balancing at fog points and determining the ideal number of classrooms, ensuring the seamless integration of fog computing solutions in real-time classroom monitoring applications.





REFERENCES

- [1] M. S. Hadi, P. A. Nugraha, I. M. Wirawan, I. A. E. Zaeni, M. A. Mizar, and M. Irvan, "IoT based smart garden irrigation system," in *2020 4th International Conference on Vocational Education and Training (ICOVET)*, Sep. 2020, pp. 361–365, doi: 10.1109/ICOVET50258.2020.9230197.
- [2] I. Gunawan, L. K. Hui, M. A. Ma'sum, and N. N. Sukawati, "Enhancing learning effectiveness by using online learning management system," in *2020 6th International Conference on Education and Technology (ICET)*, Oct. 2020, pp. 48–52, doi: 10.1109/ICET51153.2020.9276553.
- [3] R. D. Sousa, B. Karimova, and S. Gorlov, "Digitalization as a new direction in education sphere," *E3S Web of Conferences*, vol. 159, p. 09014, Mar. 2020, doi: 10.1051/e3sconf/202015909014.
- [4] M. I. Qureshi, N. Khan, H. Raza, A. Imran, and F. Ismail, "Digital technologies in education 4.0. does it enhance the effectiveness of learning? A systematic literature review," *International Journal of Interactive Mobile Technologies (IJIM)*, vol. 15, no. 04, p. 31, Feb. 2021, doi: 10.3991/ijim.v15i04.20291.
- [5] E. A. Avdeeva and O. A. Kornilova, "Influence of digital environment on the cognitive function of schoolchildren and students," *Cardiovascular Therapy and Prevention*, vol. 21, no. 3S, p. 3331, Jul. 2022, doi: 10.15829/1728-8800-2022-3331.
- [6] I. D. Wahyono, K. Asfani, M. M. Mohamad, M. Ashar, A. N. Afandi, and Aripriharta, "A new smart learning framework using artificial intelligence," in *2020 4th International Conference on Vocational Education and Training (ICOVET)*, Sep. 2020, pp. 87–91, doi: 10.1109/ICOVET50258.2020.9230323.
- [7] A. Oke and F. A. P. Fernandes, "Innovations in teaching and learning: exploring the perceptions of the education sector on the 4th industrial revolution (4IR)," *Journal of Open Innovation: Technology, Market, and Complexity*, vol. 6, no. 2, p. 31, Jun. 2020, doi: 10.3390/joitmc6020031.
- [8] J. I. Olszewska, "The virtual classroom: a new cyber physical system," in *2021 IEEE 19th World Symposium on Applied Machine Intelligence and Informatics (SAMII)*, Jan. 2021, pp. 000187–000192, doi: 10.1109/SAMI50585.2021.9378678.
- [9] E. Özgül and M. A. Ocak, "The effect of internet of things education through distance education on student success and motivation," *Journal of Educational Technology and Online Learning*, vol. 6, no. 2, pp. 403–420, May 2023, doi: 10.31681/jetol.1241362.
- [10] E. C. Wittmann, "Developing mathematics education in a systemic process," *Connecting Mathematics and Mathematics Education*, pp. 191–208, 2021, doi: 10.1007/978-3-030-61570-3_9.
- [11] R. Muthunagai, D. Muruganandhan, P. Rajasekaran, "Classroom attendance monitoring using CCTV," in *2020 International Conference on System, Computation, Automation and Networking (ICSCAN)*, Jul. 2020, pp. 1–4, doi: 10.1109/ICSCAN49426.2020.9262436.
- [12] S. A. Aslan, Y. E. Turgut, and A. Aslan, "Teachers' views related the middle school curriculum for distance education during the COVID-19 pandemic," *Education and Information Technologies*, vol. 26, no. 6, pp. 7381–7405, Nov. 2021, doi: 10.1007/s10639-021-10587-z.
- [13] M. K. Mondal, S. Banerjee, D. Das, U. Ghosh, M. S. Al-Numay, and U. Biswas, "Toward energy-efficient and cost-effective task offloading in mobile edge computing for intelligent surveillance systems," *IEEE Transactions on Consumer Electronics*, vol. 70, no. 1, pp. 4087–4094, Feb. 2024, doi: 10.1109/TCE.2024.3362396.
- [14] K. Faqih and A. N. Afandi, "Smart home fog computing architecture based on internet of things (IoT)," pp. 260–263.
- [15] R. Satra, M. S. Hadi, S. Sujito, F. Febryan, M. H. Fattah, and S. R. Busaeri, "IoAT: internet of aquaculture things for monitoring water temperature in tiger shrimp ponds with DS18B20 sensors and WeMos D1 R2," *Journal of Robotics and Control (JRC)*, vol. 5, no. 1, pp. 62–71, 2024.
- [16] K. Nagashri, S. Rajarajeswari, I. M. Imran, and N. D. Shetty, "Fog computing—characteristics, challenges and job scheduling survey," *Lecture Notes in Networks and Systems*, vol. 209, pp. 665–680, 2022, doi: 10.1007/978-981-16-2126-0_52.
- [17] D. M. Bhatia, S. Sharma, D. S. Bhatia, and D. M. Alojail, "Fog Computing mitigate limitations of cloud computing," *International Journal of Recent Technology and Engineering (IJRTE)*, vol. 8, no. 5, pp. 1732–1736, Jan. 2020, doi: 10.35940/ijrte.E6199.018520.
- [18] J. Bae, J. Lee, and S. Chong, "Beyond max-weight scheduling: a reinforcement learning-based approach," in *2019 International Symposium on Modeling and Optimization in Mobile, Ad Hoc, and Wireless Networks (WiOPT)*, Jun. 2019, pp. 1–8, doi: 10.23919/WiOPT47501.2019.9144097.
- [19] S. Subbaraj, R. Thiyagarajan, and M. Rengaraj, "A smart fog computing based real-time secure resource allocation and scheduling strategy using multi-objective crow search algorithm," *Journal of Ambient Intelligence and Humanized Computing*, vol. 14, no. 2, pp. 1003–1015, Feb. 2023, doi: 10.1007/s12652-021-03354-y.
- [20] J. Singh, P. Singh, E. M. Amhoud, and M. Hedabou, "Energy-efficient and secure load balancing technique for SDN-enabled fog computing," *Sustainability*, vol. 14, no. 19, p. 12951, Oct. 2022, doi: 10.3390/su141912951.
- [21] S. Sharma and A. Kapoor, "An efficient routing algorithm for IoT using GWO approach," *International Journal of Applied Metaheuristic Computing*, vol. 12, no. 2, pp. 67–84, Apr. 2021, doi: 10.4018/IJAMC.2021040105.
- [22] P. Costa *et al.*, "Fog computing in real time resource limited IoT environments," *Advances in Intelligent Systems and Computing*, vol. 1160 AISC, pp. 102–112, 2020, doi: 10.1007/978-3-030-45691-7_10.
- [23] C. Györgyi, P. Vörös, K. Kecskeméti, G. Szabó, and S. Laki, "Adaptive network traffic reduction on the fly with programmable data planes," *IEEE Access*, vol. 11, pp. 24935–24944, 2023, doi: 10.1109/ACCESS.2023.3255985.
- [24] A. Farahzadi, P. S. Farahsary, and J. Rezazadeh, "A survey on IoT fog nano datacenters," *Wireless Networks*, vol. 28, no. 1, pp. 173–207, Jan. 2022, doi: 10.1007/s11276-021-02829-2.
- [25] A. Nisha and R. Lavanya, "Fog computing and its role in the internet of things," in *Advancing Consumer-Centric Fog Computing Architectures*, 2018, pp. 63–71.
- [26] A. Alelaiwi, A. Alghamdi, M. Shorfuzzaman, M. Rawashdeh, M. S. Hossain, and G. Muhammad, "Enhanced engineering education using smart class environment," *Computers in Human Behavior*, vol. 51, pp. 852–856, Oct. 2015, doi: 10.1016/j.chb.2014.11.061.





BIOGRAPHIES OF AUTHORS

Tasrif Hasanuddin     received the S.T. degree in Electrical Engineering from the University of Hasanuddin, Makassar in 1998, the M.Cs. degree in Computer Science from the University of Gadjah Mada, Yogyakarta, in 2009. Currently pursuing a Ph.D. in the Department of Electrical Engineering and Informatics at State University of Malang in 2022. Research interests include the implementation of microcontrollers and their relationship with computer vision, and currently interested in fog computing implementation. He can be contacted at email: tasrif.hasanuddin.2205349@students.um.ac.id.







Mokh Sholihul Hadi     received his S.T. degree in Electrical Engineering, from Brawijaya University Indonesia in 2004. He received his M.Eng. and Ph.D. degrees in Electronics and Applied Physics from the Tokyo Institute of Technology, Japan, in 2010 and 2014. Since 2009, he has worked as Associate Professor at the Department of Electrical Engineering and Informatics, Faculty of Engineering, State University of Malang Indonesia. His current research interest is embedded IoT systems, smart devices, robotics, semiconductor devices, and nano electronics. He can be contacted at email: mokh.sholihul.ft@um.ac.id.



Sujito     received his S.T. and M.T. degree in Electrical Engineering, from Gadjah Mada University Indonesia in 2000 and 2004. He received his Ph.D. degrees in Electrical Engineering and Computer Science from the National Kaohsiung University of Science and Technology, Taiwan, in 2019. He has worked as Associate Professor at the Department of Electrical Engineering and Informatics, Faculty of Engineering, State University of Malang Indonesia. His current research interest is semiconductor technology. He can be contacted at email: sujito.ft@um.ac.id.



Rosnani     received the Ir. (Bachelor of Engineering) and M.Si. (Master of Science) degrees in Department of Plant Protection from Hasanuddin University Ujung Pandang and Department of Accounting Management in Hasanuddin University, in 1984 and 2005, respectively. Currently, she is the Deputy Chairman of Finance of STMIK Profesional Makassar. Field of her research interests include the applications of artificial intelligence, image processing, data mining. She can be contacted at email: rosnani2017@stmikprofesional.ac.id.