

## PV system applied on the new PUC-NPC inverter

Abdelhay Sadki Amari<sup>1</sup>, Ayoub El Gadari<sup>2</sup>, Abdezzahid Arbaoui<sup>1</sup>

<sup>1</sup>Department of Electrical Engineering, Chouaib Doukkali University, El Jadida, Morocco

<sup>2</sup>Department of Electrical Engineering, Higher School of Technology, Moulay Ismail University, Meknes, Morocco

### Article Info

#### Article history:

Received Dec 7, 2023

Revised Feb 22, 2024

Accepted Apr 6, 2024

#### Keywords:

NPC

PUC

PV system

PWM technique

THD

### ABSTRACT

In this article, the authors present a new competitive Packed-U-cell and neutral point clamped (PUC-NPC) 9-level converter that utilizes a small number of power switches and passive components. Only seven switches are added to a single DC source. However, the proposed converter takes benefits of the neutral point clamped (NPC) converter's capability to connect capacitors in series, all with a simple control that enables the algorithm associated to the proposed inverter operate correctly in an open loop operation. A technique of pulse width modulation (PWM) is employed to maintain capacitor voltage at desired values. The proposed inverter produces an almost sinusoidal waveform output voltage, as result, a perfectly sinusoidal charge current with minimal impact on the economy and energy consumption are optioned. The converter has been integrated with a photovoltaic system to minimize its impact on the electricity supply and enhance energy efficiency. In order to take a maximum power from the photovoltaic panel, authors employ a maximum power point tracking (MPPT) technique based on disturbance and observe (P and O). When combined with the proposed control technique, it offers a competitive system suitable for standalone use or as an energy source, eliminating the need for PI regulators or additional investments. The proposed 9-level converter has been validated through simulation, utilizing the MATLAB Simulink environment to model the proposed system. Dynamics of this later were verified by changing the load charge.

*This is an open access article under the [CC BY-SA](https://creativecommons.org/licenses/by-sa/4.0/) license.*



### Corresponding Author:

Abdelhay Sadiki Amari

Department of Electrical Engineering, Chouaib Doukkali University

El jadida, Morocco

Email: sadikiamari.a@ucd.ac.ma

## 1. INTRODUCTION

Current research is focused on power electronics to achieve more efficient energy conversion for electrical power applications and facilitate the renewable energy intregation, specifically solar energy, to support solar photovoltaic panels. Multilevel converters, use medium power switches to deliver an efficient power and convert energy from DC current side to an AC current side. Various topologies have been introduced, with cascading H-bridge (CHB) [1] and neutral point clamped (NPC) [2], largley employed in industry, and flying capacitor (FC) [3] being popular choices. The exploration of new multilevel inverter topologies that produce increased output levels while utilizing fewer power switches and DC power sources is a crucial aspect in power electronics researches. That pursuit aims to enhance quality and reduce manufacturing costs.

This study investigated the effects of applying a photovoltaic system using the new 9-level Packed-U-cell and neutral point clamped (PUC-NPC) [4] inverter, combined with the (P and O) maximum power point tracking (MPPT) technique [5], [6]. While earlier studies have explored the impact of irradiation changes on

photovoltaic voltage output. The proposed system ensures high-quality power on the load side, contributing to good energy conversion efficiency. The proposed PUC-NPC inverter is comprised of seven power switches and four capacitances, enabling it to offer nine-level output voltage through pulse width modulation (PWM) control. This control technique, based on the presence of redundant switching states, provides nine levels with a self-balancing of capacitor voltages, resulting in a low-profile design and reduced cost [7]–[10].

**2. METHOD**

**2.1. Proposed PUC-NPC 9-level topology, different switching states and the technique to balance capacitors voltages**

The PUC-NPC converter is based on the classical PUC [11], a seven-level inverter that utilizes closed-loop regulation for capacitors voltage balancing [12]–[25]. Figure 1 illustrates a single phase of the proposed topology, which based on a series association of two multilevel topologies: PUC and the NPC topologies. To operate in open loop condition, it is necessary to decrease the target of voltage number levels, leading to development of proposed system.

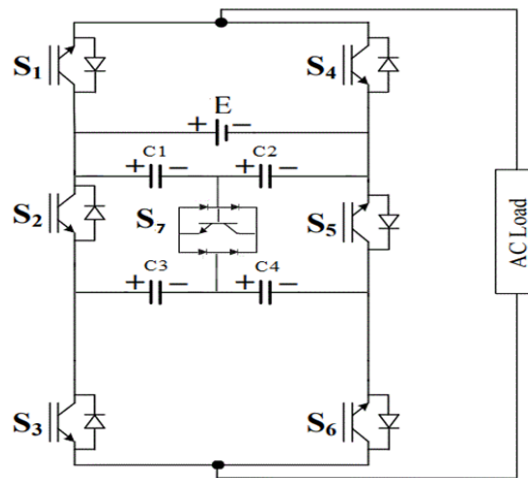

Figure 1. Proposed single phase of the PUC-NPC 9-level inverter

To generate the 9 level desired voltage we suppose that  $V_{c1} = V_{c2} = E/2$  and  $V_{c3} = V_{c4} = E/2$ . The nine required levels are duplicated in Table 1. Using the presence of redundant states, the system achieve the auto-balancing of capacitors voltage in open loop operation without using any PI regulators or filters.

Table 1. Switching sequence for the PUC-NPC 9 level inverter proposed

| State | Interconnexion      | C1    | C2    | C3    | C4    |
|-------|---------------------|-------|-------|-------|-------|
| 9     | E                   | N.E   | N.E   | N.E   | N.E   |
| 8     | $V_{c1}+V_{c4}$     | Disch | N.E   | N.E   | Disch |
| 7     | $E-(V_{c3}+V_{c4})$ | N.E   | N.E   | Charg | Charg |
| 6     | $V_{c1}-V_{c3}$     | Disch | N.E   | Charg | N.E   |
| 5     | 0                   | N.E   | N.E   | N.E   | N.E   |
| 4     | $-(V_{c2}-V_{c4})$  | N.E   | Disch | N.E   | Charg |
| 3     | $(V_{c3}+V_{c4})-E$ | N.E   | N.E   | Charg | Charg |
| 2     | $-(V_{c2}+V_{c3})$  | N.E   | Disch | Charg | N.E   |
| 1     | -E                  | N.E   | N.E   | N.E   | N.E   |

N.E: Non effect, Charg: charging, Disch: discharging

A PWM technique is assured to achive capacitors voltage balancing. No PI regulators, voltage o currents sensors are employed which makes the implementation very easy. Figure 2 presents the technique of control used.

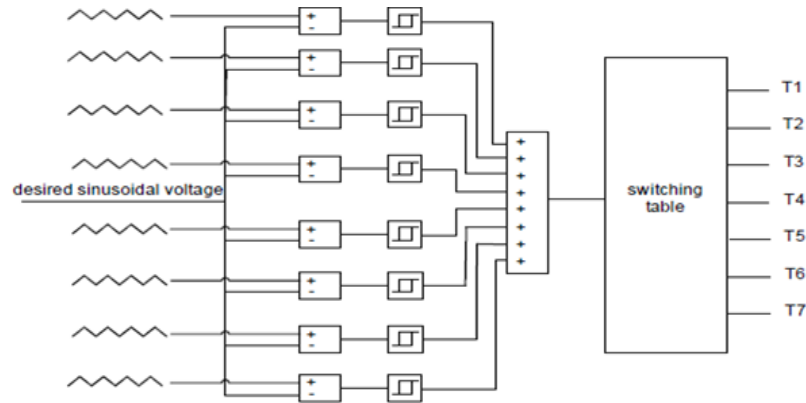

Figure 2. Switches gates pulses generation

## 2.2. Photovoltaic system based on the PUC-NPC 9 inverter

The system comprising the PUC-NPC multilevel inverter associated with a photovoltaic source consists of three main components. Firstly, there's the PUC-NPC 9 inverter, capable of providing nine levels of output voltage using only a few power electronics components. The second component is the SunPower SPR305-WHT PV system, which comprises three series-connected modules and three parallel strings. Each module consists of 96 cells. SunPower PV panels were chosen for their efficiency, quality, and ease of implementation.

To maximize power generation, a third component is employed, which involves a MPPT technique developed based on the perturb and observe (P&O) method. This technique adjusts the operating voltage to obtain maximum power from the PV system. The algorithm used for MPPT is illustrated in Figure 3 [26], where  $\delta$  represents the duty cycle and  $k$  is an integer. Additionally, Figure 4 [26] depicts the I-V and Ppv-V characteristics of the SPR 305WHT PV system.

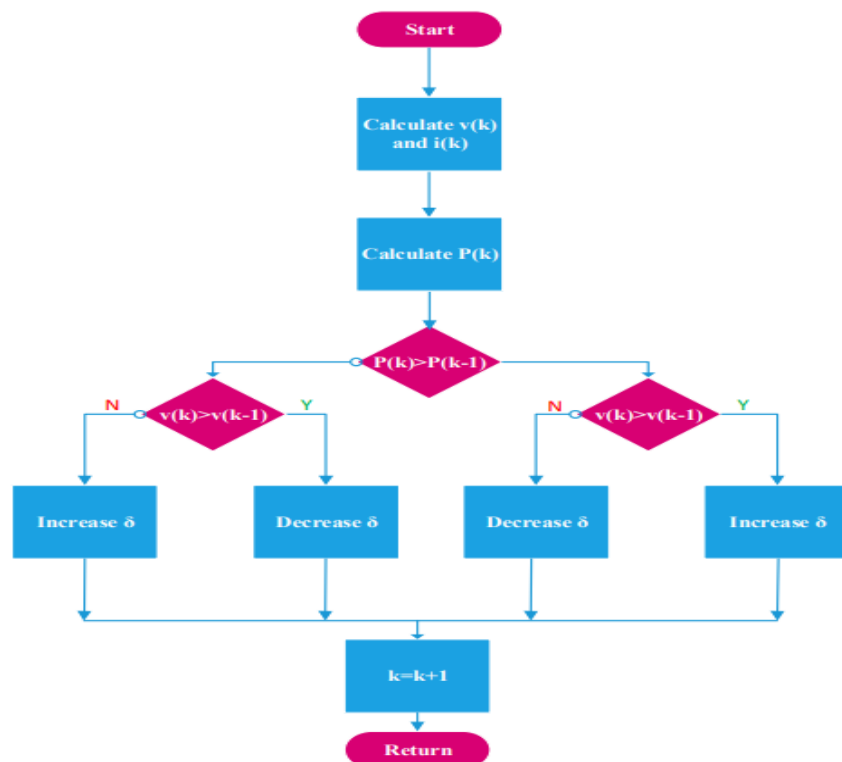

Figure 3. Principle of P&O MPPT technique

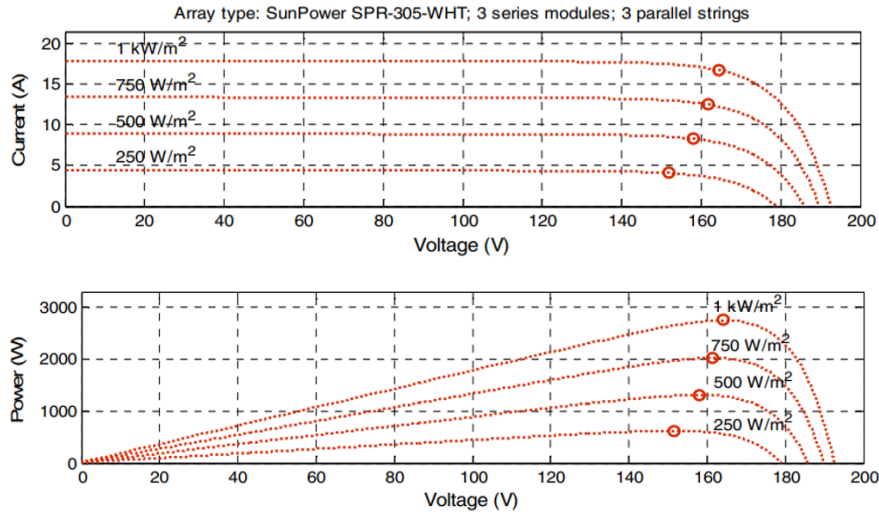

Figure 4. I-V and Ppv-V characteristics of the canadian solar CS5P-220P PV array

Each perturbation leads to either a reduction or augmentation in the power output of the PV panel. When power increases, the duty cycle should track the trend of the PV panel voltage. Conversely, if power decreases, the duty cycle should adjust in the opposite direction to the PV panel voltage evolution. This iterative cycle continues until the maximum power point is attained. Figure 4 depicts the I-V and Ppv-V characteristics of the Canadian Solar CS5P-220P PV array.

### 3. RESULTS AND DISCUSSION

To simulate the proposed system, we chose to analyze the PUC-NPC nine-level inverter using a constant DC power source. Subsequently, we introduced a constant irradiation level. However, to verify the dynamics of our system, we also incorporated variable irradiation levels in the simulation. This simulation was performed using the Matlab Simulink and SimPowerSystems environment. System parameters are presented in Table 2.

**Table 2. System parameters**

| PUC-NPC inverter    |              |
|---------------------|--------------|
| Parameters          | Value        |
| SPUC-NPC capacitors | 4000 $\mu$ F |
| Load resistor       | 15 $\Omega$  |
| Load inductance     | 10mH         |
| Switching frequency | 2000Hz       |
| SPR 305WHT PV panel |              |
| Parameters          | Value        |
| Moduls              | 3            |
| Strings             | 3            |

#### 3.1. In constant DC source

The proposed system is simulated with a constant DC source of 380 V. As depicted in Figure 5, the capacitors reach their desired voltage values. Specifically, Vc1 and Vc2 stabilize around half of the DC source, while Vc3 and Vc4 are maintained at the desired value of E/4.

This achievement is facilitated by the presence of redundant states, eliminating the need for voltage sensors or closed-loop systems. Figure 6 presents the output voltage of the inverter proposed, it is constituted from nine voltage levels. Load current is nearly sinusoidal as represented in Figure 7.

A remarkably low total harmonic distortion (THD) is attained without the use of any voltage sensor or regulation loop. The THD level of this nine-level inverter is measured at 2.31% for the current waveform, as illustrated in Figure 8. It's noteworthy that the load current THD can be further reduced by increasing the modulating signal frequency.

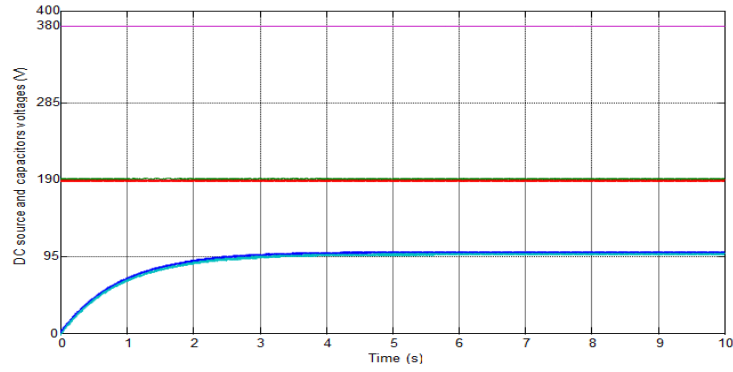

Figure 5. DC source and capacitors voltages

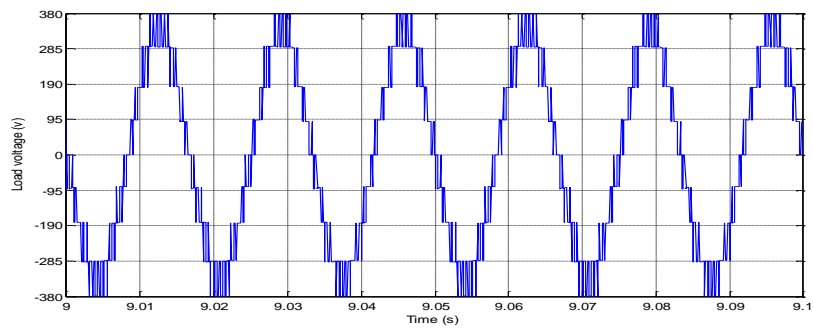

Figure 6. Load voltage waveform

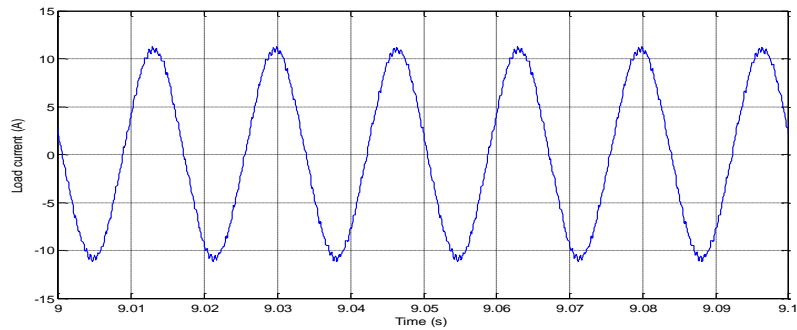

Figure 7. Load current waveform

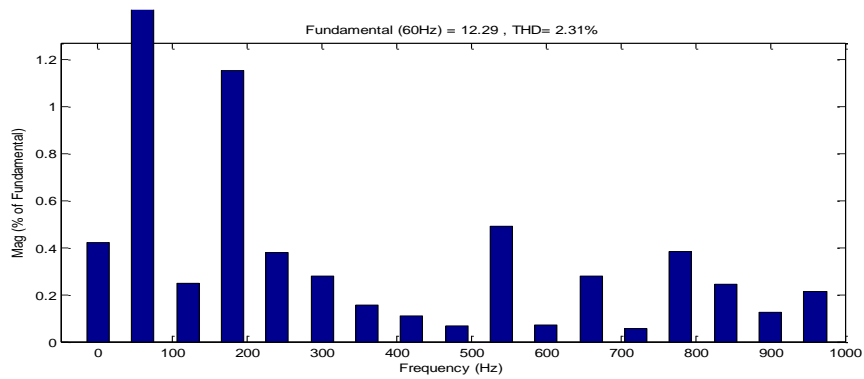

Figure 8. Zoom on the THD of the proposed inverter output current

**3.2. In constant irradiance condition**

The proposed system is attacked by a constant irradiance condition of 750 W/m<sup>2</sup>. Consequently, the MPPT technique P&O is employed to extract the maximum power, resulting in an approximate output of 2 kW, as shown in Figure 9. Simultaneously, the PV panel voltage remains in a steady state around the desired value of 165 V, as depicted in Figure 10.

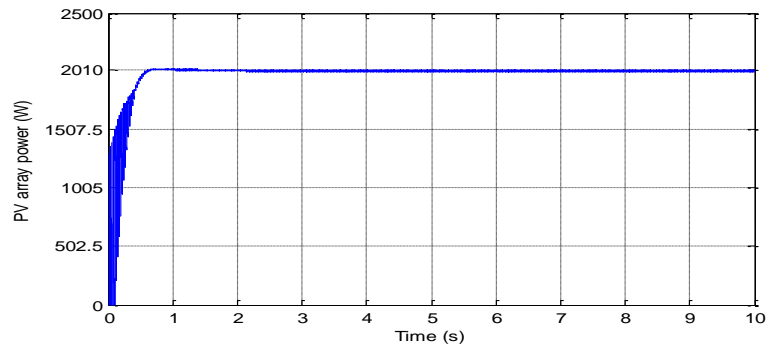

Figure 9. PV power evolution

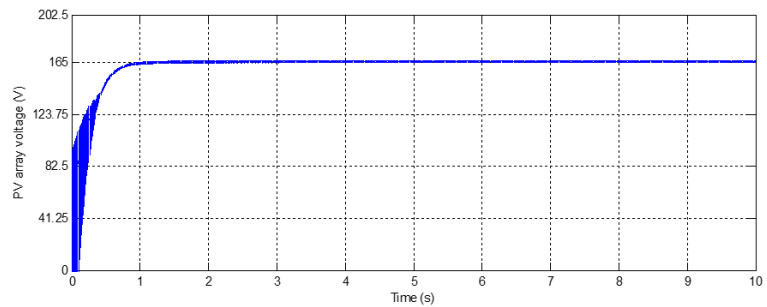

Figure 10. PV voltage evolution

As illustrated in Figure 11, the capacitors are maintained around their desired values, with capacitors 1 and 2 at half of the PV source and capacitors 3 and 4 at a quarter of the PV source. These results are achieved without the use of any active or passive filters, operating in an open loop. The load voltage consists of nine levels, as shown in Figure 12, and the load current is nearly sinusoidal, as depicted in Figure 13.

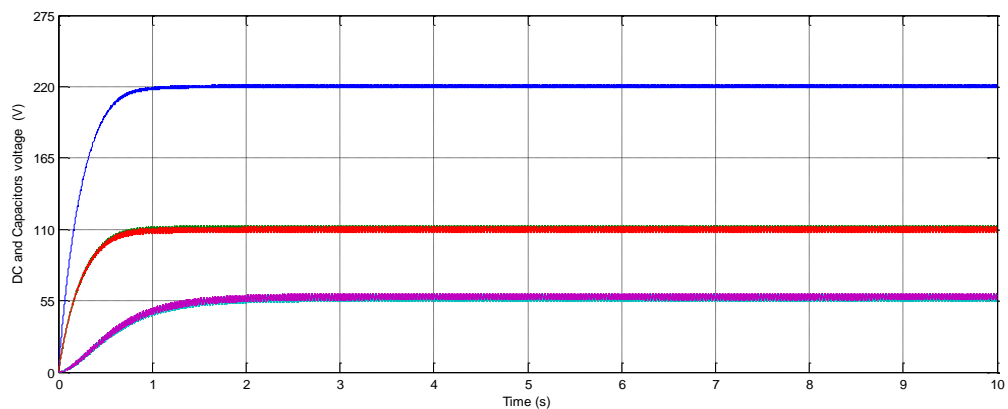

Figure 11. DC-Link and inverter capacitors voltages evolution

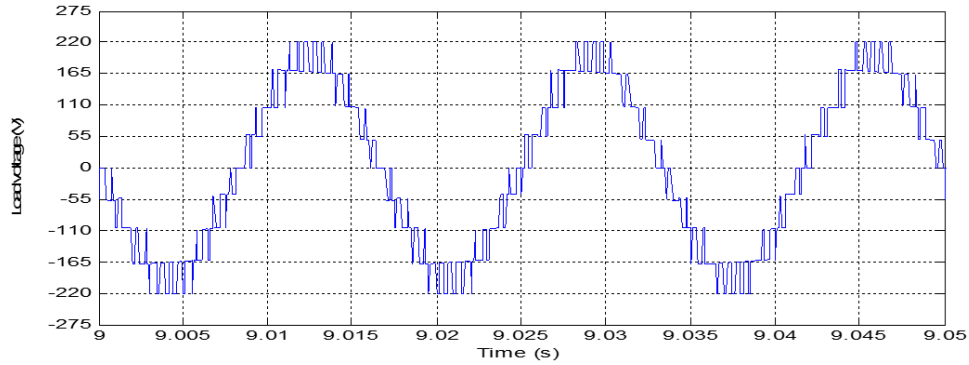

Figure 12. Load voltage

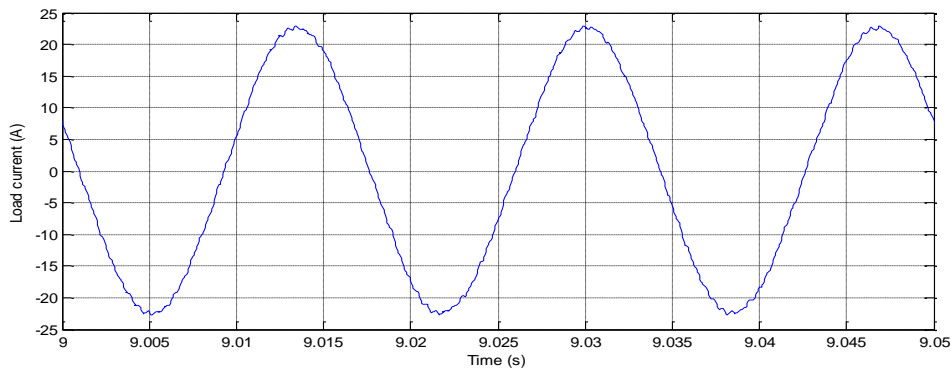

Figure 13. Load current

#### 4. COMPARISON WITH OTHER TOPOLOGIES

The proposed inverter is highly optimized, benefiting from its significant advantage of employing only seven switches, with six being current reversible and the seventh being both voltage and current reversible. Additionally, the use of a single DC source significantly reduces the cost of the conversion block. These advantages, combined with the capability to achieve self-balancing of capacitor voltages in open-loop operation through the proposed control technique, contribute to the overall efficiency of the system. Table 3 provides a comparison of the proposed inverter with recent nine-level inverters.

Table 3. Comparison with other topologies

| Topology | Switches number | DC source number | Capacitors number | Control   |
|----------|-----------------|------------------|-------------------|-----------|
| PUC-NPC  | 7               | 1                | 4                 | Very easy |
| SPUC [7] | 7               | 1                | 2                 | Easy      |
| PUC [10] | 8               | 1                | 2                 | Easy      |

#### 5. CONCLUSION



This paper introduces a novel photovoltaic system centered around the PUC-NPC inverter. Employing the SunPower SPR305-WHT PV panel, the system utilizes the P&O MPPT technique to extract maximum power. The system's response is validated initially with a constant DC source and subsequently with a PV system under 750 W/m<sup>2</sup> irradiation conditions. Simulation results confirm the paper's concepts, demonstrating that capacitor voltages are achieved in open-loop operation without the need for filters or sensors, simplifying the implementation process.

## REFERENCES



- [1] M. D. Manjrekar, T. A. Lipo, "Hybrid topology for multilevel power conversion.," *U.S. Patent*, no. 6005788, 1999.
- [2] A. Nabae, I. Takahashi, and H. Akagi, "A New Neutral-Point-Clamped PWM Inverter," *IEEE Transactions on Industry Applications*, vol. IA-17, no. 5, pp. 518–523, Sep. 1981, doi: 10.1109/TIA.1981.4503992.
- [3] T. A. Meynard and H. Foch, "Multi-level conversion: High voltage choppers and voltage-source inverters," in *PESC Record - IEEE Annual Power Electronics Specialists Conference*, IEEE, 1992, pp. 397–403. doi: 10.1109/PESC.1992.254717.
- [4] A. S. Amari, A. El Gadari, A. Arbaoui, and Y. Ounejjar, "New Nine-Level PUC-NPC9 Inverter with Natural Balancing of Capacitors Voltages," in *2020 International Symposium on Advanced Electrical and Communication Technologies, ISAECT 2020*, IEEE, Nov. 2020, pp. 1–5. doi: 10.1109/ISAECT50560.2020.9523663.
- [5] A. Ghamrawi, J. P. Gaubert, and D. Mehdi, "A new dual-mode maximum power point tracking algorithm based on the Perturb and Observe algorithm used on solar energy system," *Solar Energy*, vol. 174, pp. 508–514, Nov. 2018, doi: 10.1016/j.solener.2018.09.013.
- [6] V. Kumar and M. Singh, "Derated Mode of Power Generation in PV System Using Modified Perturb and Observe MPPT Algorithm," *Journal of Modern Power Systems and Clean Energy*, vol. 9, no. 5, pp. 1183–1192, 2021, doi: 10.35833/MPCE.2019.000258.
- [7] A. El Gadari *et al.*, "New Nine-Level SPUC Inverter Using Single DC Source," in *IECON Proceedings (Industrial Electronics Conference)*, IEEE, Oct. 2019, pp. 1892–1897. doi: 10.1109/IECON.2019.8927358.
- [8] H. Vahedi, P. Labbe, and K. Al-Haddad, "Sensor-Less Five-Level Packed U-Cell (PUCS) Inverter Operating in Stand-Alone and Grid-Connected Modes," *IEEE Trans. Ind. Informat.*, vol. 12, no. 1, pp. 361–370, 2016.
- [9] H. Vahedi and K. Al-Haddad, "PUC5 Inverter—A Promising Topology for Single-Phase and Three-Phase Applications," in *IECON 2016-42nd annual Conference of the IEEE Industrial Electronics Society, Italy*, 2016.
- [10] Y. Ounejjar, A. El Gadari, M. Abarzadeh, and K. Al-Haddad, "PWM Sensor-less Balancing Technique for the Fifteen-Level PUC Converter," in *2018 IEEE Electrical Power and Energy Conference, EPEC 2018*, IEEE, Oct. 2018, pp. 1–6. doi: 10.1109/EPEC.2018.8598443.
- [11] Y. Ounejjar, K. Al-Haddad, and L. A. Grégoire, "Packed U cells multilevel converter topology: Theoretical study and experimental validation," *IEEE Transactions on Industrial Electronics*, vol. 58, no. 4, pp. 1294–1306, Apr. 2011, doi: 10.1109/TIE.2010.2050412.
- [12] F. Sebaaly, H. Vahedi, H. Y. Kanaan, N. Moubayed, and K. Al-Haddad, "Design and Implementation of Space Vector Modulation-Based Sliding Mode Control for Grid-Connected 3L-NPC Inverter," *IEEE Transactions on Industrial Electronics*, vol. 63, no. 12, pp. 7854–7863, Dec. 2016, doi: 10.1109/TIE.2016.2563381.
- [13] R. Castillo, B. Diong, and P. Biggers, "Single-phase hybrid cascaded H-bridge and diode-clamped multilevel inverter with capacitor voltage balancing," *IET Power Electronics*, vol. 11, no. 4, pp. 700–707, Apr. 2018, doi: 10.1049/iet-pel.2017.0009.
- [14] H. Y. Hasirci and A. M. Vural, "Design and Experimental Verification of PUC Multilevel Inverter-Based PMSG Wind Energy Conversion System," *Applied Sciences*, vol. 13, no. 24, p. 13018, Dec. 2023, doi: 10.3390/app132413018.
- [15] D. A. Ruiz-Caballero, R. M. Ramos-Astudillo, S. A. Mussa, and M. L. Heldwein, "Symmetrical hybrid multilevel DCAC converters with reduced number of insulated DC supplies," *IEEE Transactions on Industrial Electronics*, vol. 57, no. 7, pp. 2307–2314, Jul. 2010, doi: 10.1109/TIE.2009.2036636.
- [16] K. Al-Haddad, Y. Ounejjar, 599 LA Gregoire - US Patent 9, 331, and U. 2016, "Multilevel electric power converter," *Google Patents*, vol. 2, no. 12, 2016.
- [17] Y. Ounejjar and K. Al-Haddad, "A novel six-band hysteresis control of the packed U cells seven-level converter," in *IEEE International Symposium on Industrial Electronics*, IEEE, Jul. 2010, pp. 3199–3204. doi: 10.1109/ISIE.2010.5637579.
- [18] A. Ammar *et al.*, "Grid tie indirect matrix converter operating with unity power factor under double space vector modulation," in *Proceedings of the IEEE International Conference on Industrial Technology*, IEEE, Mar. 2017, pp. 1498–1503. doi: 10.1109/ICIT.2017.7915588.
- [19] R. Chen *et al.*, "Modeling, Analysis, and Reduction of Harmonics in Paralleled and Interleaved Three-Level Neutral Point Clamped Inverters with Space Vector Modulation," *IEEE Transactions on Power Electronics*, vol. 35, no. 4, pp. 4411–4425, Apr. 2020, doi: 10.1109/TPEL.2019.2939727.
- [20] A. N. Babadi, O. Salari, M. J. Mojibian, and M. T. Bina, "Modified Multilevel Inverters with Reduced Structures Based on PackedU-Cell," *IEEE Journal of Emerging and Selected Topics in Power Electronics*, vol. 6, no. 2, pp. 874–887, Jun. 2018, doi: 10.1109/JESTPE.2017.2767499.
- [21] H. Makhmreh, M. Sleiman, O. Kukrer, and K. Al-Haddad, "Lyapunov-Based Model Predictive Control of a PUC7 Grid-Connected Multilevel Inverter," *IEEE Transactions on Industrial Electronics*, vol. 66, no. 9, pp. 7012–7021, Sep. 2019, doi: 10.1109/TIE.2018.2879282.
- [22] A. K. Singh and R. K. Mandal, "Switched-capacitor-based five-level inverter with closed-loop control for grid-connected PV application," *Computers and Electrical Engineering*, vol. 108, p. 108686, May 2023, doi: 10.1016/j.compeleceng.2023.108686.
- [23] T. Sun, M. Shi, X. Xiao, P. He, Y. Ji, and Z. Yuan, "Parameter Design of Current Double Closed Loop for T-Type Three-Level Grid-Connected Inverter," *Energy Engineering: Journal of the Association of Energy Engineering*, vol. 120, no. 7, pp. 1621–1636, 2023, doi: 10.32604/ee.2023.026948.
- [24] B. Balaji, S. Kannan, G. D. Kumar, and P. Srinivas, "Closed Loop Sliding Mode Controller Controlled Quazi Z Source Inverter Fed Permanent Magnet Brushless DC Motor Drive," in *2023 2nd International Conference on Smart Technologies and Systems for Next Generation Computing, ICSTSN 2023*, IEEE, Apr. 2023, pp. 1–7. doi: 10.1109/ICSTSN57873.2023.10151665.
- [25] Y. Zhang, Y. Zhang, and Y. Zhang, "Implementation of Automatic DSP Code Generation Based on Closed-loop Algorithm for Three-level Inverters," *Journal of Physics: Conference Series*, vol. 2503, no. 1, p. 012100, May 2023, doi: 10.1088/1742-6596/2503/1/012100.
- [26] A. El Gadari *et al.*, "Photovoltaic System Based on the PUC9 Inverter," in *IEEE International Symposium on Industrial Electronics*, IEEE, Jun. 2019, pp. 2059–2064. doi: 10.1109/ISIE.2019.8781359.





**BIOGRAPHIES OF AUTHORS**

**Abdelhay Sadiki Amari**    was born in Errachidia, Morocco, in June 1992. He received the engineer degree in electronics engineering. Now is a Ph.D. student in Physical Sciences and Engineering at the Faculty of Sciences of El Jadida. His current research interests are the multilevel power converters. He can be contacted at email: [sadikiamari.a@ucd.ac.ma](mailto:sadikiamari.a@ucd.ac.ma).



**Ayoub El Gadari**    was born in Meknes, Morocco, in November 1994. He received the engineer degree in mecatronics engineering. Now is a Ph.D. student in Physical Sciences and Engineering at the Faculty of Sciences of Meknes. His current research interests are the multilevel power converters. He can be contacted at email: [a.elgadari@edu.umi.ac.ma](mailto:a.elgadari@edu.umi.ac.ma).



**Prof. Dr. Abdezzahid Arbaoui**    was born in Errachidia, Morocco. His current research interests are electronic properties of materials; Thermal properties of materials; Electronic transport phenomena; Highly corroded electronic systems; Superconducting materials. He can be contacted at email: [a\\_arbaoui@hotmail.com](mailto:a_arbaoui@hotmail.com).