

## Energy Harvesting Device Based on Spatial Electric Field in Substations

Hongwei Li<sup>1\*</sup>, Ganrong Peng<sup>2</sup>

<sup>1</sup>Technology College, State Grid Corporation of China, Jinan, China

<sup>2</sup>State Grid Jinan Power Supply Company, Jinan, China

\*Corresponding author, e-mail: dragonlhw@163.com

### Abstract

*It is rich in electric field energy in high voltage substations while it is hardly collected and utilized. A novel energy harvesting device based on spatial electric field is presented in this paper, which is composed of capacitive energy collector and conditioning circuit. A simulation model of the energy collector is established to study the relationship between output voltage and its structural parameters and is verified by no-load tests. There are some restraining factors such as output voltage unstable in the traditional conditioning circuit. A new conditioning circuit is designed to overcome the problems and this new circuit is more effectively. This paper designs a new device to harvest the electric field energy within substations and it can provide broad potential use in the future.*

**Keywords:** smart grid, energy harvesting, capacitive energy collector, conditioning circuit

**Copyright © 2014 Institute of Advanced Engineering and Science. All rights reserved.**

### 1. Introduction

Smart grid has broad prospects in the future [1], which requires advanced sensor and measuring technology. Therefore, the wireless sensors network has wide application prospect in the smart grid. But the problem of its energy supply has not effectively solved [2-3], some solutions such as increasing battery energy density, using new energy transfer method [4], etc., cannot fundamentally solve it due to the disadvantages of security and large energy consumption. The energy harvesting technology can effectively solve the problem of energy supply, which collects energy from the surrounding environment [5-9] (such as solar energy, vibrational energy, thermal energy, electromagnetic energy, etc.) and converts it into electricity.

In the high voltage substations, the energy harvesting technology based on solar energy is limited to application space and weather conditions and it cannot afford a constant supply of energy; the device based on vibrational energy cannot be used on the surface of electrical equipments for the sake of insulation and security; and some new devices based on thermal energy and sound energy can hardly meet demand of power supply because the energy source is too weak. Therefore, the researchers began to study the energy harvesting technology based on space electromagnetic energy in substations because it can overcome the above weakness.

There is plenty of electromagnetic energy in modern high voltage substations and around transmission lines, and it provides a basis for energy scavenging system based on electric field energy. Some measured data suggest that the maximum of AC electric field strength in a 500kV substation can be up to 18kV/m and it makes this energy harvesting technology viable [10]. Though there is strong electric field strength in high voltage substation, the power frequency is 50Hz and its energy density is poor. The energy harvesting device based on electric field should take full advantage of the poor energy density and reduce the energy loss as far as possible.

The energy harvesting device consists of two parts: capacitive collector and conditioning unit. The capacitive converter is a key component of the system. There is need for further research about the energy harvesting effect of topological structures, geometrical parameters and the external electric field. Another key part is conditioning unit and it consists of rectifier, chopper, energy storage, and regulator to keep the output voltage stable. Therefore,

this paper is mainly about the two parts and will further develop the research on energy harvesting system based on electric field energy.

## 2. Optimized Research on Capacitive Energy Collector

Capacitive energy collector is the basis of the energy harvesting device, which determines electric energy conversion ability and efficiency. Therefore, it is necessary to establish simulation models for different capacitive energy collectors, study its efficiency and operating characteristics of different topological structures and geometric parameters in complex electric field conditions.

### 2.1. Design and Optimization of the Energy Collector

A flat-plate energy collector consists of two parallel metal circular plates which are supported by three nylon pillars. Establish a simulation model of flat-plate energy collector by ElecNet/Infolytica, as shown in Fig.1, where the external electric field is produced by an electric field generated unit composed of two metallic plates.

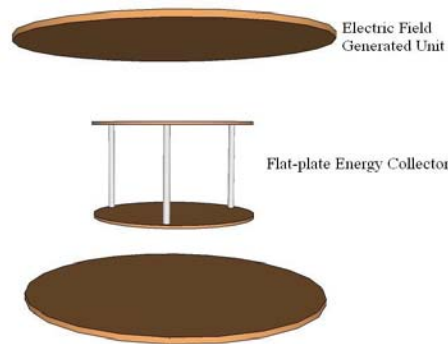

Figure1. Frame Diagram of Flat-plate Energy Collector

As Figure 1 shows, establish the simulation model by Ansoft/Maxwell, the electric field generated unit is consist of two circular copper plates whose radius and thickness is respectively 500mm and 5mm. The energy collector lies right in the middle of the generated unit. In order to analyze the relationship between the geometrical parameters and energy harvesting effect, change the area and height of the collector and study the output voltage. In the simulation model, the electric field strength applied on the generated unit is 1kV/m and the radius of the energy collector is 10cm.

The height of the collector has an effect on the output voltage as Figure 2(a) shows. The output voltage is be proportional to the height and its slope which is the electric field strength between the collector is 0.51kV/m but less than 1kV/m. This may be caused by the local electrostatic shielding effect of the parallel plates or caused by the energy loss of the generated unit. In Figure 2(b), the output voltage has nothing to do with the thickness of the collector. The result shows that the thickness has no effect to the potential difference between the collector, thus it has no reflection on the output voltage, energy storage and energy harvesting efficiency. The electric potential of any plate can rise with the increase of thickness because it is an equipotential body in the electric field and its potential is determined by its relative position in the electric field. Therefore, the metal plate of the collector should be as thinner as possible if it can meet the manufacturing technology level and economy.

The plate area of the collector can make a difference on the energy harvesting effect. Figure 2(c) shows that the radius of the plate is almost no influence on the output voltage, with the radius increases the output voltage decreases a little. Though the plate area can hardly influence the output voltage, the energy stored by the capacitor is proportional to the plate area. The bigger is the plate area, the greater is the capacitance then the more is energy stored by the capacitor. The plate area cannot affect the energy harvesting efficiency and output voltage, so the plate area should be the bigger the better when it meet the design condition.

The direction of the applied electric field has a significant impact on the output voltage as Figure 2(d) shows. Assume that the angle between the central axis of the collector and the axis of the electric field generated unit is  $\alpha$ . When the angle changes from  $0^\circ$  to  $90^\circ$ , record the output voltage of the collector. It is clear that the angle  $\alpha$  is  $0^\circ$ , the output voltage is the biggest and the energy harvesting effect is the best. In order to have a best energy harvesting effect, the energy collector should be put perpendicular to the external electric field.

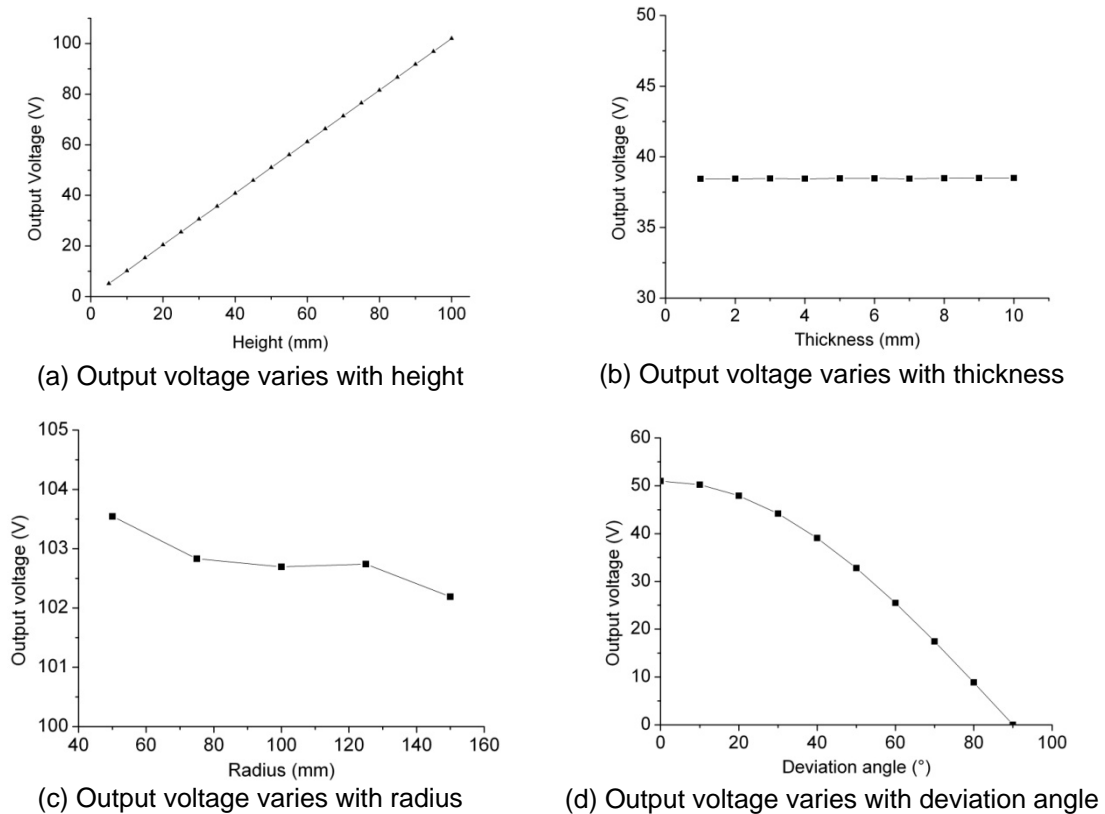

Figure 2. Output Voltage Characteristics by Simulation

The simulation results show that the output voltage varies with the external power frequency electric field. The output voltage is directly proportional to the collector's area and height while has nothing to do with its thickness. In fact, the electric field may come from different directions so as that its energy harvesting effect is inefficient. Therefore, a new topological structure is raised to increase its energy harvesting efficiency. It is similar to the flat-plate but the upper plate is replaced by a hemispherical shell. The approximate closed metal surface offers electromagnetic shielding for the conditioning circuit and the electric field distortion is small enough to avoid the phenomenon of point discharge.

## 2.2. No-load Test of the Energy Collector.

To test and verify the actual characteristics of the energy collectors, set up an experiment platform as shown in Figure 3. It is composed of high voltage testing transformer, electric field generator, voltage divider and an oscilloscope. The electric field generator consists of two parallel metal plates with area of  $1\text{m}^2$ , four insulating pillars with a height of 1m. It is connected to a 50Hz AC power grid through the high voltage testing transformer. The no-load test is aimed at studying the energy collectors' energy harvesting effect and its influencing factors so the experiment is tested in a relative low voltage.



Figure 3. The Experimental Test Platform

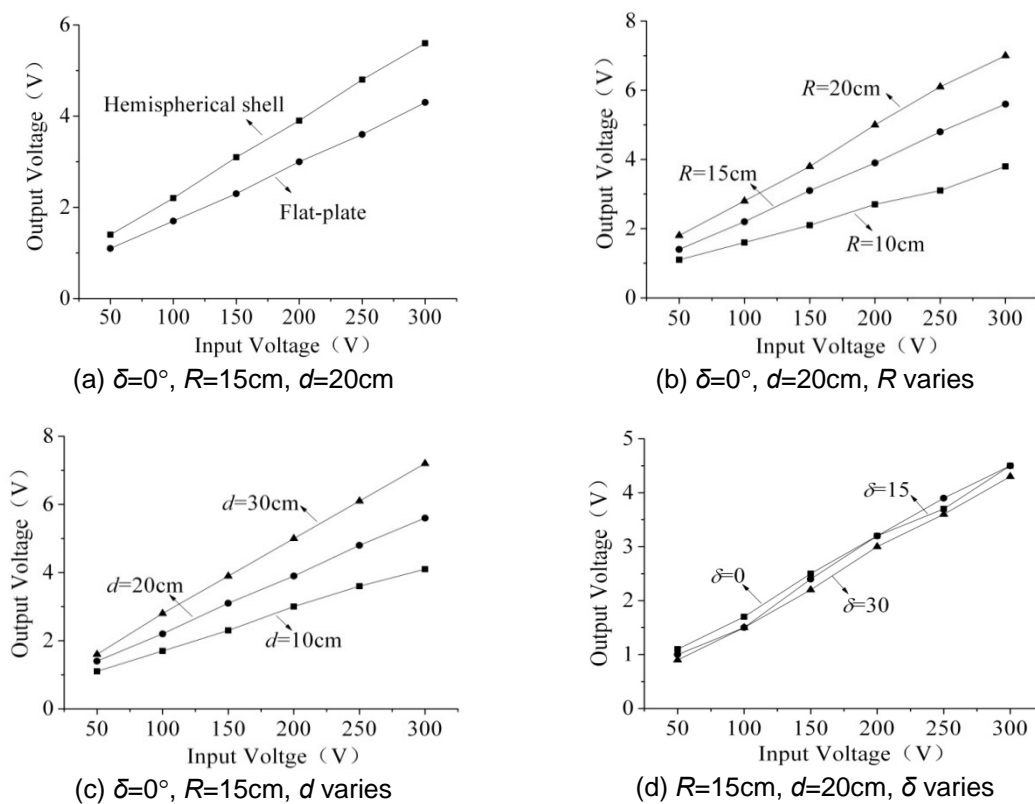

Figure 4. Output Voltage Characteristics under Different Conditions

For different energy collectors with varied structures and geometric parameters, put them in the electric field generator to observe their output voltage waveform by oscilloscope. Regulate the transformer to keep its output voltage changing between 50V and 300V to observe the output voltage. Assume the angle between electric field direction and medial axis of the collector is  $\delta$ . When the radius and height of the flat-plate collector and hemispherical shell one is the same and  $\delta=0^\circ$ , the hemispherical shell one has a higher output voltage, as Figure 4(a) shows, which the voltage is all peak-to-peak value. For the hemispherical shell collector, change its radius  $R$  and height  $d$  to observe its output voltage and the results show that the output voltage of the collector is increased with radius  $R$  and height  $d$  increase, as Figure 4(b) and (c) show. Because the direction of electric field has a big influence on the energy harvesting effect, keep the radius  $R$  and height  $d$  unchanged in the test, change the angle  $\delta$  to observe the output voltage. Due to measurement error and electric field distortion of the electric field generator, the

output voltage of the flat-plate collector is decreased when increasing the angle  $\delta$  but the hemispherical shell one keep stable, as Figure 4(d) shows.

The experimental results show that the energy harvesting effect of the hemispherical shell collector is better than the flat-plate one with the same radius and height. The radius, height and electric field intensity can influence the energy harvesting effect of the hemispherical shell collector and is approximately proportional to its output voltage. The energy harvesting effect of the hemispherical shell collector has nothing to do with the angel  $\delta$  changing in the experiments when the angle  $\delta$  is below  $30^\circ$  because of measurement errors, the electric field distortion of the electric field generator and the angle range limitation.

### 3. Conditioning Circuit

The output voltage of the energy collector is determined by the external electric field. It can generate power frequency voltage within power frequency electric field and it cannot power directly the sensors. Therefore, it needs a conditioning circuit for the device to regulate the output voltage [11]. A typical conditioning unit consists of rectifier, storage, and voltage stabilizing at least. Considering the energy harvested by the collector is not much enough and the circuit needs consume some energy, the conditioning topology should not be complicated.

In the experimental test platform as Figure 3 shows, the collector is placed in the electric field generated unit. There is an equivalent capacitor formed between the upper plate of the generated unit and the upper plate of the collector, which is written as  $C_1$ . The capacitance of the collector itself is named as  $C_2$ . There is also an equivalent capacitor between the bottom plate of the generated unit and the bottom one of the collector, noted as  $C_3$ . In the applications, the energy collector is placed under the high voltage electrodes so there are electrodes above the upper plate of the collector while ground under the bottom one. The high voltage electrodes are very long and far from the converter, the equivalent capacitor formed between electrodes and the upper plate of collector can also be approximately considered capacitor, called  $C_1$ . Assume that the voltage of the electrode is  $u_i$ . Therefore, the voltage source  $u_i$  and three capacitors are in series in the equivalent simplified model, shown in Figure 5. By using the thevenin-norton's theorem of two-terminal network, the model in Figure 5 can be simplified further as Figure 6 shown, where  $u_{eq}$  and  $C_{eq}$  denote the equivalent voltage and capacitance and their equivalent relations can be expressed by formula (1).

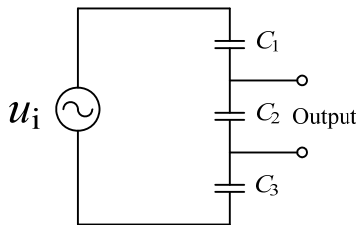

Figure 5. Equivalent Model of Collector

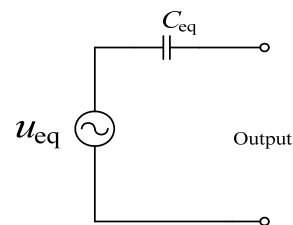

Figure 6. Simplified Circuitry of the Collector

$$\begin{cases} C_{eq} = \frac{C_1 C_3 + C_1 C_2 + C_2 C_3}{C_1 + C_3} \\ u_{eq} = \frac{C_1 C_3}{C_1 C_3 + C_1 C_2 + C_2 C_3} u_i \end{cases} \quad (1)$$

The output voltage can catch up well with the changes of the collector, and it can generate power frequency output voltage within power frequency electric field. Therefore, a simplified equivalent model of the collector as Fig.6 shows is used to replace the energy collector to simplify the analysis. A typical conditioning circuit is shown in Fig.7, where a bridge rectifier is connected to the energy collector, and a capacitance  $C$  is used for regulating and storing the voltage.

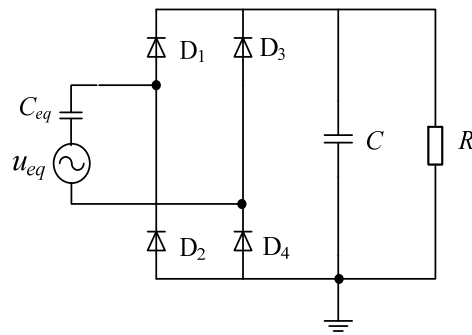

Figure 7. A Typical Conditioning Circuit

In practice, most of time the wireless sensors work in dormant time, their equivalent resistance and power consumption are large, but conversely they are in work state only in a fraction of time, the instantaneous energy consumption increases. The sudden change of the load has the potential to cause disorder of the bridge rectifier. Consequently, there are two obvious disadvantages of traditional conditioning circuit: the output voltage is not stable and the equivalent resistance of the load is changeable.

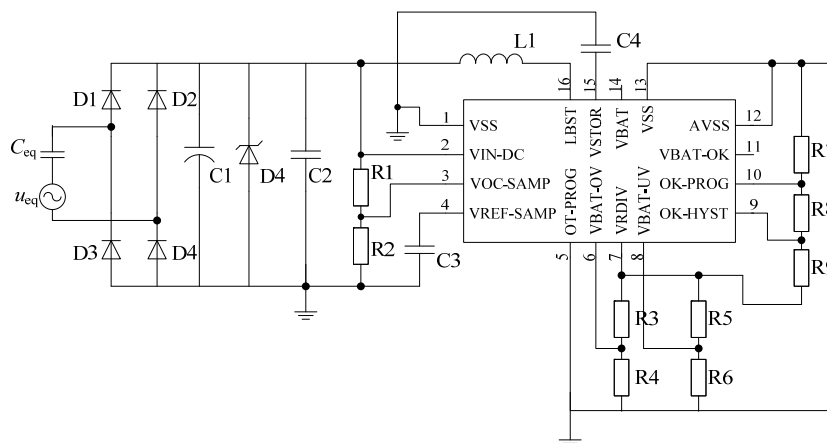

Figure 8. A Novel Conditioning Circuit Based on BQ25504

In order to overcome these problems, a new topology is presented, shown in Figure 8. The circuit is based on the ultra low-power chip: BQ25504. The circuit mainly includes three parts: bridge rectifier, storage capacitance and boost converter with battery management. The capacitance  $C_1$  stores the energy from the collector  $u_{eq}$ , so it requires a bulky capacity to implement the energy storage, and usually we can choose a 16V/0.1F or more aluminum electrolytic capacitor as the storage unit. The voltage of  $C_1$  should be kept below 16V, so the voltage-regulator diode  $D_4$  is connected between the two pins of  $C_1$ . In practice, P6KE15CA can be chosen as voltage-regulator diode  $D_4$ , which has a wide power range of 500W.  $D_4$  can ensure the voltage of  $C_1$  always stay below 15V to protect it. The subsequent circuit is the main body of the design, which is based on BQ25504 to regulate the output voltage. It owns double output, one is the sensors load and another is a rechargeable battery. When the circuit has a large load, the battery can release energy and it can store energy in return when the load is low, thus it makes the circuit more effectively.

#### 4. Conclusion

It designs a new topology of the energy collector and establish its simulation model to study the relationship between the output characteristics and the topology's structural features. Establish an experimental platform and do no-load test to verify the actual characteristics of the energy collectors. Analyze the main problems existed in the traditional conditioning circuit and present a new circuit to overcome these problems. The new circuit has a good output characteristic and is very suitable for large fluctuations of the load in applications.

#### References

- [1] YX Yu, WP Luan. *Smart Grid and Its Implementations*. Proceedings of the CSEE. 2009; 29(34): 1-8.
- [2] AP Joseph, S Thad. Energy Scavenging for Mobile and Wireless Electronics. *IEEE Trans. on Pervasive Computing*. 2005; 4(1): 18-27.
- [3] DS Lee. Wireless and Powerless Sensing Node System Developed for Monitoring Motors. *Sensors*. 2008; 8(8): 5005-5022.
- [4] B Jiang, RS Joshua, P Matthai. Energy Scavenging for Inductively Coupled Passive RFID Systems. *IEEE Trans. on Instrumentation and Measurement*. 2007, 56(1): 118-125.
- [5] YG Sun. Study on Structure Vibration Wireless Sensor Based on Solar Cell. *Noise and Vibration Control*. 2007; 4: 132-133.
- [6] D Simone, F Vittorio, G Michele. Autonomous Sensor System with Power Harvesting for Telemetric Temperature Measurements of Pipes. *IEEE Trans. on Instrumentation and Measurement*. 2009; 58(5): 1471-1478.
- [7] E Lefeuvre, A Badel, C Richard. A Comparison between Several Vibration-powered Piezoelectric Generators for Standalone Systems. *Sensors and Actuators A: Physical*. 2006, 126(2): 405-416.
- [8] SS Nathan, AP Joseph. Energy Scavenging with Shoe-mounted Piezoelectrics. *IEEE Micro*. 2001; 21(3): 30-42.
- [9] C Wang, ZG Zhou, YG Ou. Research and Development on Thermoelectric Generators. *Electrical Measurement and Instrumentation*. 2010; 47(532): 40-44.
- [10] M Zhu, MD Judd, PJ Moore. *Energy Harvesting in Substations for Powering Autonomous Sensors*. Sensor Technologies and Applications. Athens. 2009: 246-251.
- [11] Chunhui Yu, Li Zhang, Jinxin Huang, et al. Conditioning Topology Analysis and Optimization of Capacitive Energy Harvesting Device. *Automation of Electric Power Systems*. 2012; 36(9): 86-90.