

A Three-phase AC-Voltage Regulator System

Guoshun Zhou*, Tu Ya, Shukun Zhao

Dalian Neusoft University of Information, Dalian, China

*Corresponding author, e-mail: zhouguoshun@neusoft.edu.cn

Abstract

Three-phase AC-voltage regulator systems using silicon controlled rectifier (SCR) have been broadly applied in industrial field. This paper introduces a novel design of three-phase AC-voltage regulation trigger circuitry with SCR and STM32 microcontroller, and presents its application in an energy-saving design of oil extractor control system. This design employs photoelectric isolation technique and the inter-phase of three-phase power supply itself, only three groups of triggering signals are required to control the six thyristors' conducting angles. The generation of high-precision triggering signals and PID control regulator functions are realized by programming the multiple high-performance timers and the AD interface of a STM32 microprocessor. Experiments and in-field tests have shown the feasibility of the proposed scheme.

Keywords: SCR, trigger circuit, three-phase asynchronous motor, STM32 microcontroller

Copyright © 2014 Institute of Advanced Engineering and Science. All rights reserved.

1. Introduction

The key point of a thyristor three-phase power-supply regulator is to calculate the trigger angle in accordance with the inter-phase regular of the three-phase power supply, then to trigger the corresponding six thyristors reliably and effectively when collect the power supply voltage or current synchronization signal accurately. The traditional thyristor trigger circuit is divided into analog and digital circuit trigger modes. Furthermore the digital trigger mode is divided into dual-pulse trigger synchronizing with supply voltage, wide pulse trigger synchronizing with supply voltage, dual-pulse trigger synchronizing with power phase current, and so on. These trigger modes control the trigger thyristors turning on and off, in need of the synchronization signal as a reference, according to the pre-designed sequence. Even if disturbed outside, the sequence should not change [1, 2].

So as to achieve high reliability, high precision of the three-phase voltage regulation must satisfy the following conditions: accurate synchronizing signal acquisition, high precision and strong anti-interference capability of the thyristor trigger pulse and isolation of output. In order to achieve objectives above, after refer to the other researches, we proposed this design using the highly performance 32-bit STM32 microcontroller combining specific synthetic trigger circuit of main circuit. This method has been validated through the actual experiment and verify the reliably of controlling three-phase motor load voltage.

2. The Overall Designs of the Phase-shift Trigger Regulator System

The phase-shift trigger voltage regulation system is composed of the output phase to phase voltage detection circuit, zero-crossing synchronization signal detection circuit, phase sequence detection circuit, the STM32 core and peripheral circuit, trigger pulse generation and the output circuit, photoelectric isolating and driving circuit of SCR, and voltage regulating circuit of SCR, as shown in Figure 1. The system can calculate the power factor angle according to the detected zero synchronization signals and the phase difference of current and voltage of load. Additionally, it can regulate the output voltage by adjusting the triggering angle of output trigger pulse sequence, so as to greatly improve the power factor.

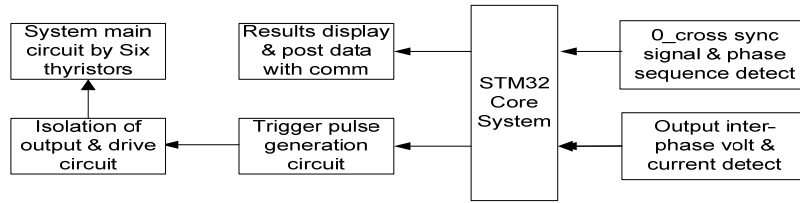

Figure 1. Structure Diagram of the SCR Regulator System

3. The Design and Analysis of Voltage Regulation Circuit and Trigger Pulse Sequence

A typical wave of three-phase power is illustrated in Figure 2. We know that the split three-phase waves (U, V, W) are completely symmetrical, and their differences between each two phase are $120^\circ (2\pi/3)$. The current in this situation is switched in every $60^\circ (\pi/3)$, and its switching order convert regularly according to the change of inter-phase voltage. The intersection points among the three-phase waves are the natural conversion points of rectification in non-control time. As shown in Figure 2, 1~6 Points are the earliest moments which can be triggered by SCR, and these six points are starting points of calculation to regulate voltage for U phase trigger angle α under the pure resistive load conditions. In this Figure, the angle of 1 point from zero-crossing point for U phase voltage is $30^\circ (\pi/6)$.

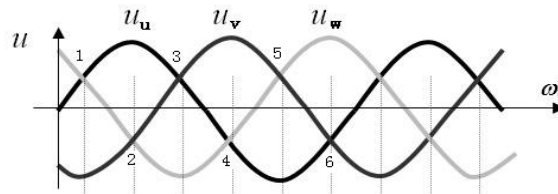

Figure 2. Diagram of the Three Phase AC

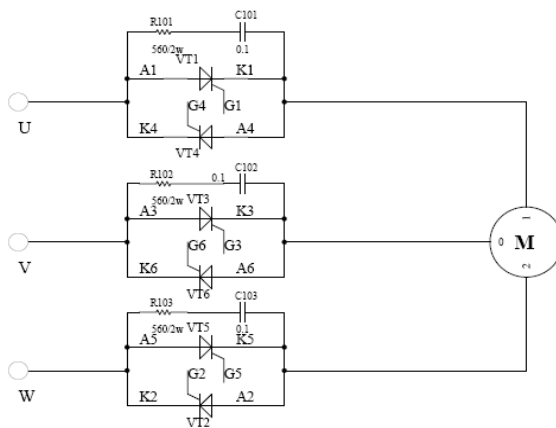

Figure 3. The Main Circuit Topology of System

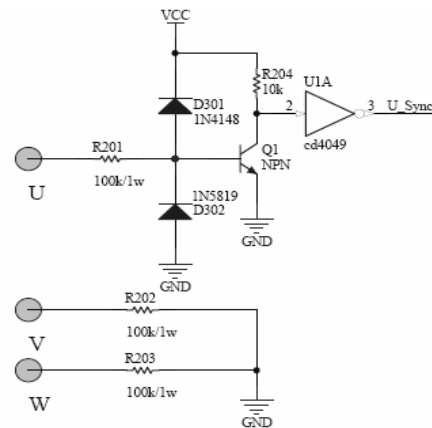

Figure 4. Schematic Diagram of the O_cross Sync Signal Generate Circuit

Figure 3 is the SCR voltage regulating circuit of three-phase asynchronous motor [3], which contains VT1~VT6 and three groups of RC snubber circuits. The principle is that the order of VT1~VT6 every 60° , two thyristors are triggered at trigger angle α [$\alpha \geq \max(\varphi, \gamma)$, where φ is power angle, γ is phase difference between zero-crossing and natural phase change point]. Namely, at the time of the trigger angle, trigger every thyristor as well as trigger the

corresponding thyristor such as VT2 simultaneously. Therefore the three-phase asynchronous motor voltage regulation can be realized by controlling trigger angles and circulating trigger corresponding thyristors in every 60° in the order (VT1, VT2), (VT2, VT3), (VT3, VT4), (VT4, VT5), (VT5, VT6), (VT6, VT1), (VT1, VT2)... [9, 10].

The synchronization signal collection circuit of U-phase voltage is shown in Figure 4. In this paper, three-phase voltage (U, V, W) are connected to a public point via 100k/1W resistors, which is considered as a reference point (digital ground) for strong and weak electricity. Firstly, U-phase voltage is clamped to TTL, and Q1 outputs square wave that inverse with a sine wave. In addition, U-phase voltage can generate square wave that has the same phase with U-phase using CD4096. Finally, the signal is U-phase voltage zero-crossing synchronization signal called U_Sync.

In this paper, signal generating and driving thyristor trigger circuit is designed shown in Figure 5. J1 is a wiring terminal socket connecting thyristor. U10~U15 are photoelectric couplers, which can isolate the STM32 control signal from strong power. This circuit features is to apply only three groups of triggering signals to control the six thyristors. It reduces in a half number of CPU control signals, so as to simplifying the complexity of control software effectively.

The starting points of the trigger pulse signals are computed in STM32, according to the power angle φ and the necessary down-regulated voltage. The U-phase voltage synchronization signal is considered as reference signal. The cycle interval of these trigger pulse signals must be 60° .

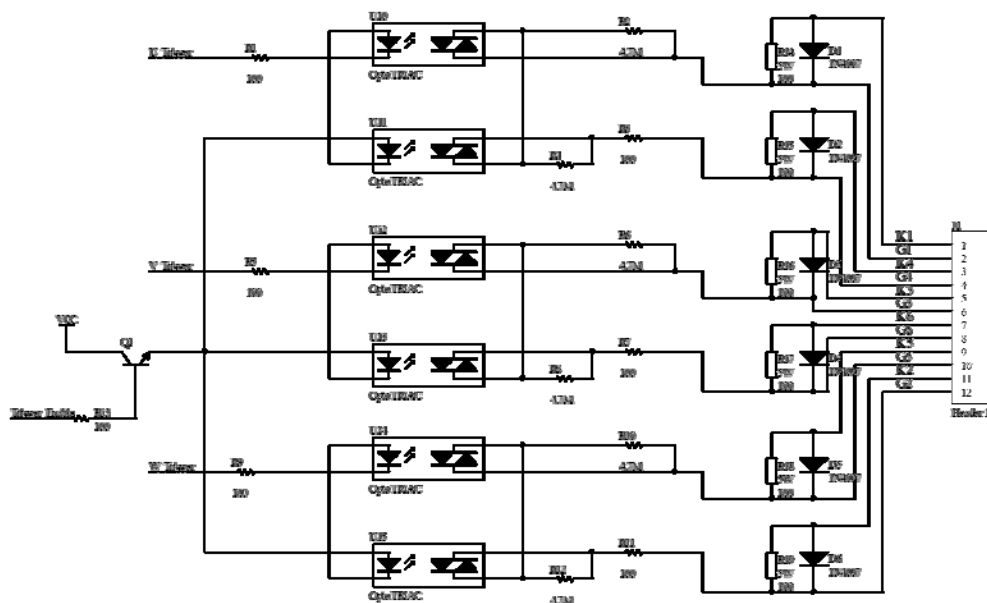

Figure 5. Schematic Diagram of the SCR Flip-flop Circuit

After analysis, the designed trigger pulse signal sequences Figure in this paper is shown in Figure 6. For U_Trigger, V_Trigger and W_Trigger, they use U-phase voltage synchronization signal as reference signal. As shown in this figure, the pulse phase difference among U_Trigger, V_Trigger and W_Trigger is 60° . In one cycle ($\omega t \in [0, 2\pi]$), U_Trigger, V_Trigger and W_Trigger generate four highly dependent pulses. These pulses are generated periodically by STM32 and always appear in the stationary phase, as long as the trigger angle parameter is not changed [7, 8].

In order to more clearly describe the principle of this circuit, this paper introduces a voltage regulation equivalent circuit of three-phase asynchronous motor that is shown in Figure 7. In this figure, the designator of resistance, capacitor and diode are consistent with Figure 3~Figure 5, and S1~S6 are strong electricity switches of photoelectric couplers. In the Figure 6 and Figure 7, K4, K6 and K2 are respectively connected with three-phase power supply, and

S1~S6 can be opened when there is no trigger pulse. Because of the gate current cannot reach to the minimum gate DC current that is the necessary of the thyristor from blocking to opening during the each phase current commutating, therefore the motor cannot turn when three-phase power supply does not load the motor.

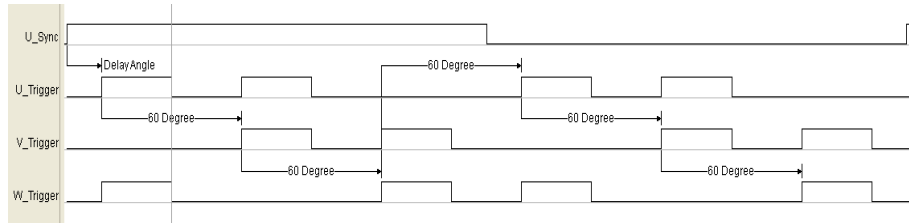

Figure 6. Timing Chart of the SCR Trigger Signals

During the period $\omega t \in [0, \pi]$, the positive half-round of the U-phase case, set the U_Sync zero-crossing point as the benchmark. After the delay angle (the triggered angle α in the Figure 6) the trigger pulses U_Trigger and W_Trigger are issued simultaneously, which equivalent to S1, S2, S5 and S6 switches are closed. As time has passed the natural commutation point (the point1 in figure1) of U and W. Because of the U-point voltage greater than the W point voltage, so the current can flow from point U (K4) to the point W (K2) by R15, R3, S1, S2, R14, L1, L3, R18, S6, S5, R11 and R19. At this time, K4 point voltage is higher than G4, G1 point voltage higher than K1, K5 point voltage higher than the G5, G2 point voltage higher than K2. According thyristor characteristic can be drawn: as long as the G-point voltage is higher than K-point voltage and current direction consistent with the direction of the thyristor, then this thyristor can be triggered, namely VT1 and VT2 are conducted, which consistent with design ideas. During the period $\omega t \in [\pi, 2\pi]$, in terms of U-phase negative half-round, same principle, not repeat analysis.

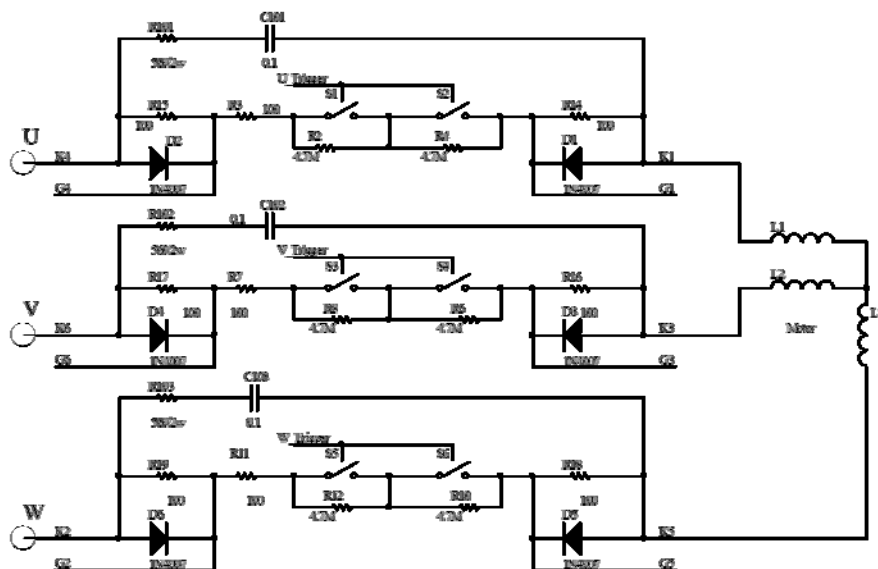

Figure 7. Equivalent Circuit of Voltage Control for Asynchronous Motor

Through the above analysis, if the proper three groups of trigger signals (Figure 6) was generated, applied with the circuits in Figure 3 to 5, it's to control the input voltage of three-phase motor effectively by adjusting the value of the triggering angle α and achieve the purpose of regulating.

For standard pure resistive load, as long as triggered at a particular time point after the natural flow changing points, that will make the corresponding thyristor conducting. Otherwise, when the falling edge of the trigger pulse positions in the point before a natural commutation point, that will cause a missing trigger. So in a pure resistive load case, if the trigger pulse width across a natural flow changing point, then the corresponding commutated thyristor is conducting immediately, as well as output with full voltage. Therefore, when apply regulating control; ensure that the rise edge of trigger pulse must lag behind the natural flow changing point.

Contrasting to pure resistive load, for motors and the other inductive loads, that may delay a power angle φ [3, 4]. The regulating triggering angle α should $\geq \max(\varphi, \gamma)$. As larger as increasing the width of trigger pulse W (guarantee $30^\circ < W < 60^\circ$) will be more appropriate.

4. System Software Design

System main chip adopts ST microelectronics company production STM32 ARM Cortex M3 architecture, development platform use Keil MDK. The software adopts the modular programming ideas, divided into data acquisition module, trigger signal producing module, PID control module, communication module and human-computer interaction module. System software structure diagram is shown in Figure 8.

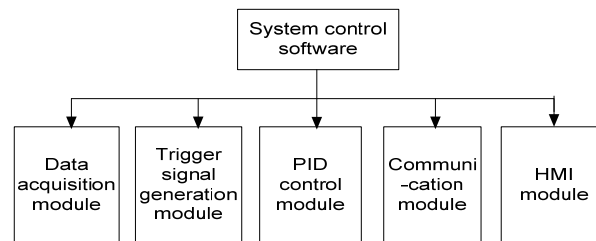

Figure 8. Structure Diagram of the Software SCR Control System

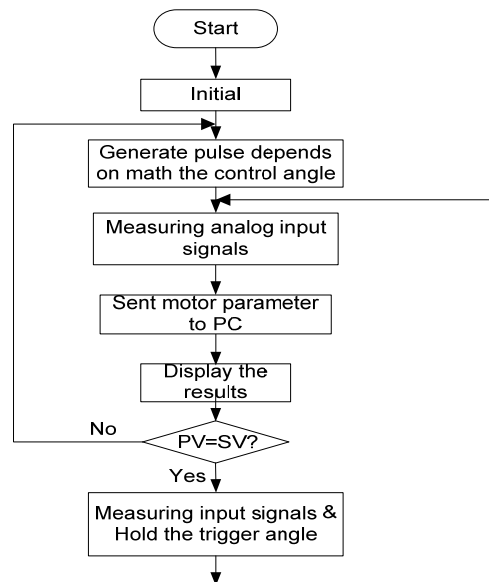

Figure 9. Flow Chart the Control Software

Among them, the data acquisition module is responsible for the collection by transformer and output signal regulate circuit and voltage (SCR regulating value), for the use of

PID control module to do PV value; Trigger signal producing module is mainly used to occur at a certain Angle control corresponding trigger a wave of thyristor voltage regulation effect; PID control module to complete the control voltage value (SV) to a given task [4]; Communication module is responsible for the completion of the regulating voltage and the control Angle parameter to 9600 baud rate output to the role of the computer; Human- Machine Interaction module completed by keyboard and LCD display panel for manual testing. Control software flow chart is shown in Figure 9.

5. Experiment Applications

This system is applied for the electricity saving project of pumping units on oil field. As long as connect the equipment to a three-phase power supply and a three-phase asynchronous motor referring to the requirement correctly, the system will automatically track the load. When the load is light, adjust the voltage to be low; when heavy, to be high [5, 6]. Because of the limitation features of thyristor, adjustable voltage cannot be less than 200V AC. Otherwise, because the conduction angle becomes bigger, too many low order harmonic waves generated, that might cause cut-off motor stalling. As shown in Figure 10, the system generates one right trigger signal in accordance with the requirements. During actual operation, the system achieves the expected results stable and reliable.

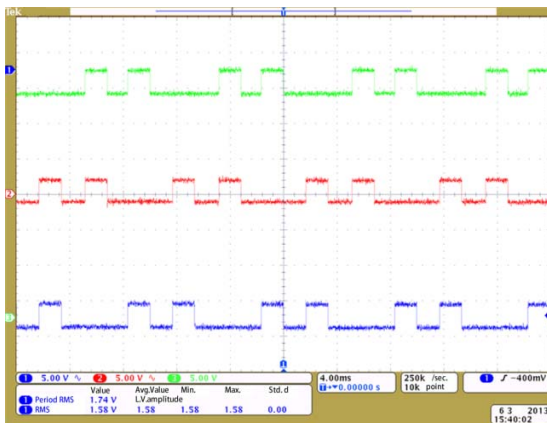

Figure 10. Display Chart of the Trigger Signals

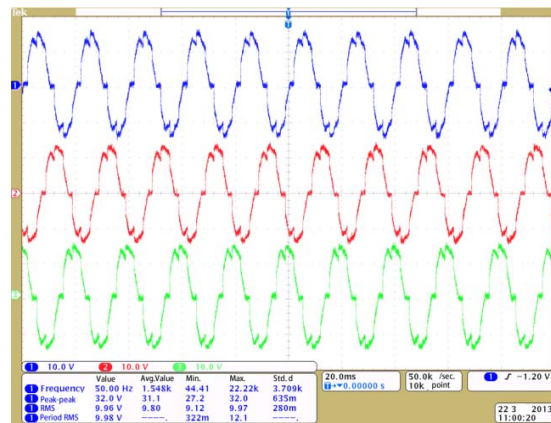

Figure 11. The Wave of Regulator Output at 30° with Resistive Load

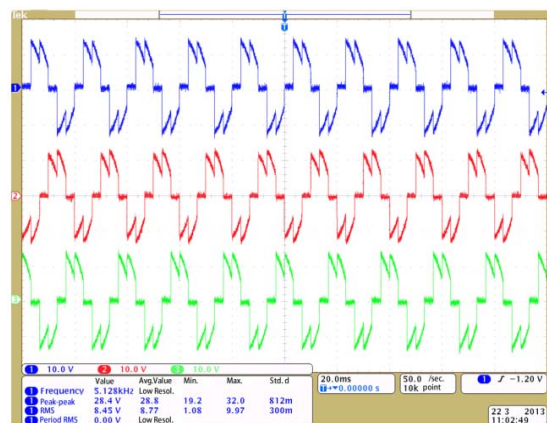

Figure 12. The Wave of Output at 60° with Resistive Load

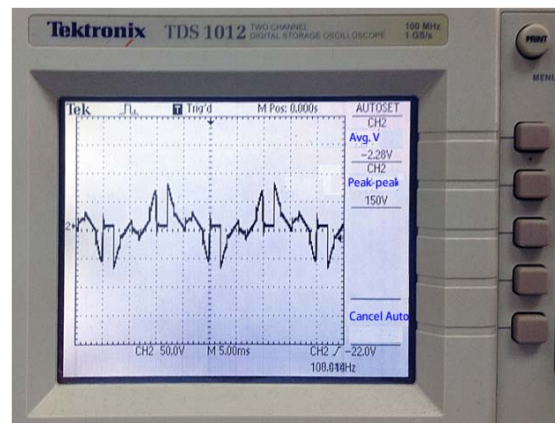

Figure 13. The Wave of Output at 90° with Inductive Load

The every phase output wave with resistive load at 30° and 60° conduction angle are show in Figure 11 and Figure 12. Furthermore the inter-phase voltage wave of output with inductive load at 90° conduction angle is show in Figure 13 [11].

In order to verify the accuracy of the thyristor regulator is given as follows (1), (2) formula of the conduction angle in a certain AC voltage RMS calculation.

Figure 14 shows the waveform for calculating effective voltage RMS values of pure resistive load at 0°~60° (using formula (1)) and 60°~120° (using formula (2)). According to ones' figures of pure resistive load, motor load (light) and theoretical calculation are spreaded out in Figure 15, which illustrates the trends of theoretical value and pure resistive load are basically same. After the triggering angle at 54° inductive load gets involved to regulate the voltage (on three-phase asynchronous motor). It means that the motor load is light, nevertheless, the power angle is relatively large (low power factor).

$$\begin{cases}
 U_{rms} = \sqrt{\frac{4}{2\pi} \int_{\frac{\pi}{3}+\alpha}^{\frac{2\pi}{3}+\alpha} \left(\frac{\sqrt{6}U_0 \sin(\omega t)}{2}\right)^2 d(\omega t)}, & 0 < \alpha \leq 60^\circ & (1) \\
 U_{rms} = \sqrt{\frac{4}{2\pi} \int_{\frac{\pi}{3}+\alpha}^{\pi} \left(\frac{\sqrt{6}U_0 \sin(\omega t)}{2}\right)^2 d(\omega t)}, & 60^\circ < \alpha \leq 120^\circ & (2)
 \end{cases}$$

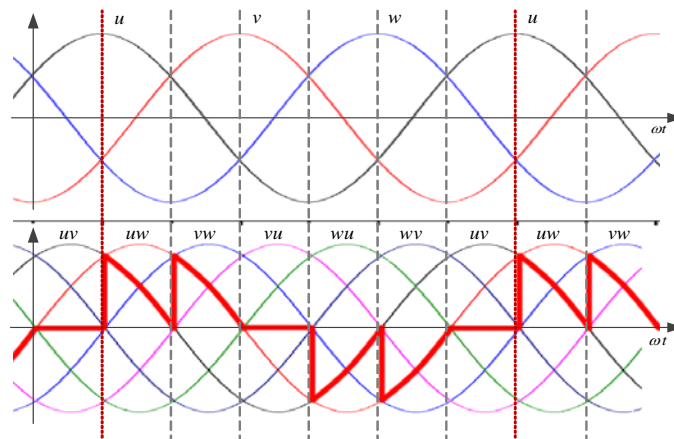

Figure 14. The Output Standard Wave of at 60° with Resistive Load for Math U_{rms}

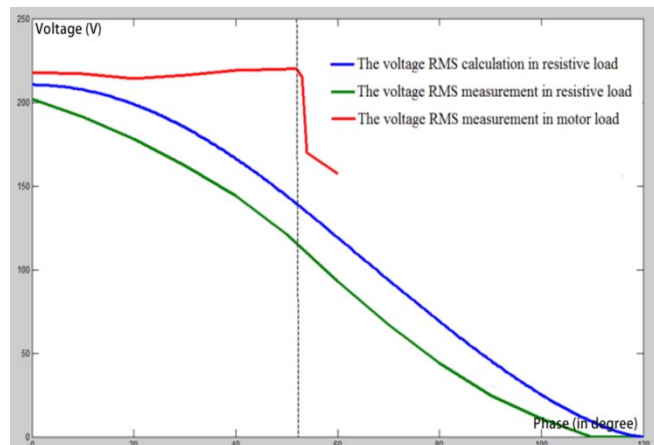

Figure 15. The Chart of Regulator Output at 0° to 120° with Resistive and Inductive Load

6. Conclusion

This system uses high performance STM32 microcontroller to design a photoelectric isolation controlled thyristor to trigger pulse signal and its drive circuit. It can output 30°~60° wide pulse trigger signal, meanwhile avoid that the drive mode can only adopt narrow pulse or narrow pulse sequence. Software is designed and developed in modules to improve the robustness and reliability of the system also carrying on the design in the future. The actual operation results show that the system have accurate, stable and reliable characteristics and meet the design requirements.

References

- [1] HAO H, LI H. Design of SCR trigger based on single-chip microcomputer. *Electronic Design Engineering*. 2009; 2: 62-66.
- [2] Huang M, LU J, Peng Y. Research on Trigger Methods for Thyristor AC-Voltage Regulator. *Power Electronics*. 2004; 4: 54-55.
- [3] Huang H, Jiang X. Study on soft-start with three-phase AC voltage adjustment for three-phase asynchronous motor and on energy saving control. *Electric Drive for Locomotives*. 2010; 4(10): 10-15.
- [4] LIU J. The Design of AVR Singlechip Computer the Efficiency Under three Different Step Motor Permanent Torque Load Optimizes the Controller. *Electric Drive for Locomotives*. 2010; 4(10): 10-15.
- [5] SUN L. The analyzation and research on the three-phase asynchronous motor intelligent saving energy controller. *Machine Tool Electric Apparats*. 2007; 34(5): 18-20.
- [6] Wang L, Han C. A design on one kind of pumping unit electricity saving controller. *Journal of the Hebei Academy of Sciences*. 2007; 24(1): 203-205.
- [7] Huang H, Jiang X, QIU R. Saber Emulation and Control of the Three phase Induction Motor in Alternating Current Voltage Regulation Circuit. *Power Electronics*. 2005; 39(2): 78-80.
- [8] SONG X, YANG J, RONG Q. Design of digital trigger based on FPGA. *Journal of Xi'an University of Engineering Science and Technology*. 2009; 23(4): 98-102.
- [9] CHENG H, YIN G. An improved anti-interference method of SCR trigger circuit. *Electric Welding Machine*. 2008; 38(12): 93-94.
- [10] LIU Y. Study of Digital Trigger System in Thyristor AC Regulator. *Jilin Normal Journal: Natural Science Edition*. 2007; 28(3): 121-124
- [11] Tan K, Luan X, Meng X. Design of 5-20 KHz/70KW Medium Frequency Induction Heating Power Supply. *Proceedings of the First International Symposium on Test Automation & Instrumentation*. Beijing, 2006; 3.