

Design on Controlling-Management System of Gas Station

Xiaoning Jiang¹, Jing Liu^{*2}

Zhejiang Gongshang University, Hangzhou, China

*Corresponding author, e-mail: jiangxiaoning@mail.zjgsu.edu.cn¹, ontheway@pop.zjgsu.edu.cn²

Abstract

With the sustained and rapid growth of domestic fuel consumption, consumers have made more and more high demand on the service of gas station. A stable and efficient refueling system which based on IC card is developed in this paper. The main purpose of this system is to realize the communication of pos terminal and tanker efficiently through protocol conversion, and the required functions of pos terminal and tanker are also achieved. In order to monitor the gas station much more conveniently, we design a real-time monitoring front-end interface which based on Ajax technology, and we can also control the tanker through the front-end interface. A stable refueling system can improve the economic benefit and company's core competitiveness. For it can provide scientific management and effective control of money, staff, oil, oil depot, equipment and so on. So refueling system has realistic necessity and important meaning of improving the working efficiency of the gas station and reducing the operational of the various costs.

Keywords: real-time, stable, interface, architecture, protocol conversion

Copyright © 2014 Institute of Advanced Engineering and Science. All rights reserved.

1. Introduction

Advanced international oil company emphasizes the construction of information technology, which improves the economic benefit through information management technology. In recent years, the number of gas station has a big increase in our country, but the quality is still relatively lag, the most important of which is the backward information management [1-5]. This causes to increase cost, poor efficiency and low core competitiveness for company. This means that China's oil and petrochemical industry will face the strong pressure of international competition. There for promoting the construction of informatization is an important support of becoming a transnational enterprise group with strong international competitiveness. So to design a stable refueling system is critically needed to save costs, realize information management and improve core competitiveness. This system is designed to change the present situation of gas station, which supplies a better solution of employee's arduous and inefficient task [6, 7]. In this paper we discussed the transaction process of gas station in detail and designed a system about business pattern and real-time monitoring of gas station.

Compared with other types of refueling system, the main advantages are as follows:

- (1) Realize relevant preferential by POS terminals;
- (2) Provides functionality for real-time monitoring oil gun and trading data which based on B/S;
- (3) Easy to put into use without changing original system of station, and can be very convenient to add more business requirements.

The structure of the paper is as follows: we first detail the system architecture in section 2, introduce the system's functions in detail in section 3, we give an overview of relevant key technology in Section 4, section 5 introduce the database design, section 6 concludes the paper.

2. System Structure

In this section, we will discuss the structure of this system mainly from the following aspects: physical architecture, logical architecture, runtime architecture and development architecture.

2.1. Physical Architecture

Physical architecture describes the element of the system, the relationship of each element and how to deploy them to hardware, it can reflect the organization of software systems when the system is running.

The physical architecture of the system is shown in Figure 1.

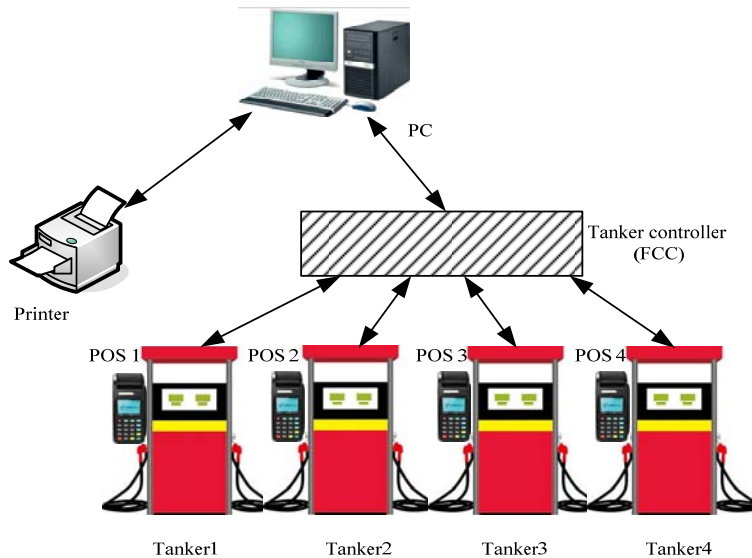

Figure 1. Physical Architecture

This system is mainly responsible for the communications of FCC(Tanker controller)and pos terminals, receive data from FCC and send commands to pos terminals or FCC, another important part is the real-time monitoring interface which based on B/S in the structure of LAMP, through which we can also send command to FCC and control oil gun conveniently.

2.2. Logical Architecture

Logical architecture means that we can classify the system into several logical unit, and every unit performe their own functions. The logical architecture of the system is shown in Figure 2.

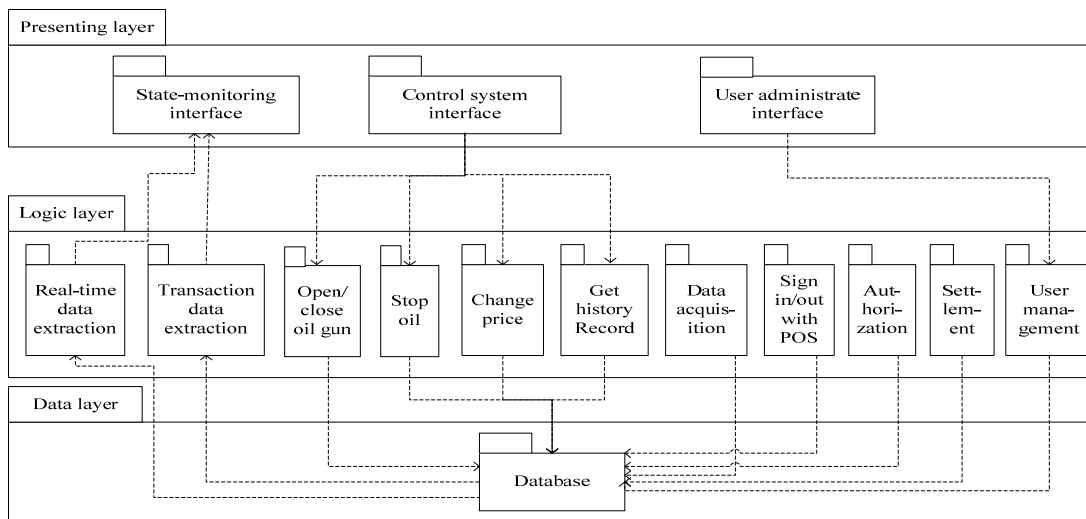

Figure 2. Logical Architecture

Presenting layer is the outermost layer of the three layers, which is closest to users, and is used to display data, receive user input and provide interfaces to support human interaction with business processes. This system mainly includes oil gun state and transaction data monitoring interface, control interface and administrative user interface.

Business logic layer is the core part of the three layers, it mainly focuses on the formulation of business rules, implementations of business processes and design of relevant business requirements. It means that this layer is related to the business domain. The role of the business logic layer is critical to the three layers, it is in between the presenting layer and data layer, which play the role of connecting link of the two layers. In this system, the business logic layer mainly includes getting real-time data and transaction data, changing prices, opening or closing oil guns, stopping refueling, calling back lost history data, signing in or signing out with POS terminals and so on.

Data layer is responsible for the access to the data, it can be a database, text files and so on. We now use MySQL and some text files as the data layer. In this layer, we should provide the interfaces to realize the access of data.

2.3. Runtime Architecture

This part details how to schedule background processes, as you can see from the following picture, we call this system as GKS, POS-1, POS-2 means POS terminals and FCC-1, FCC-2, FCC-3 means different tanker controllers. The runtime architecture of the system is shown in Figure 3.

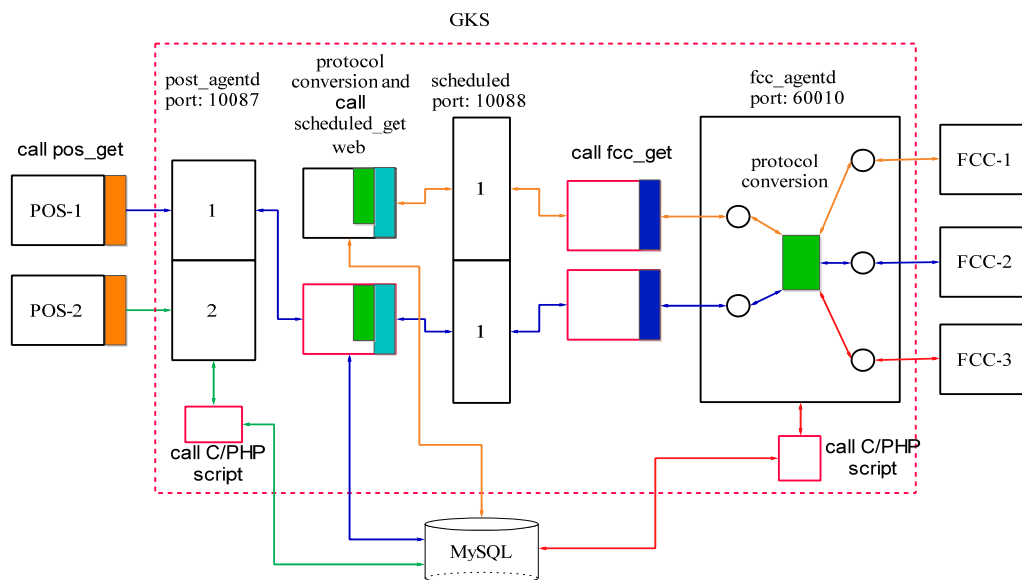

Figure 3. Runtime Architecture

This system mainly consists of four kinds of processes:

1. **pos_agentd**

It is responsible for the interaction of POS and scheduled. Its functions are as follows:

- (1) Send requests to scheduled in the way of **schedule get**.
- (2) Send to POS terminals the results that the script returns, and write error logs to the log file if necessary.
- (3) Invoke scripts and complete the operation of the database.

2. **scheduled process**

It is responsible for the interaction of **pos_agentd** and **fcc_agentd**, invokes scripts and sends requests to **fcc_agentd** in the way of **fcc_get** and then returns the result to the requester.

3. **fcc_agentd**

It is responsible for the interaction of **scheduled** and **FCC**.

Its functions are as follows:

(1) For the requests which comes from scheduled, fcc_agentd is responsible for protocol conversion, and then send it to FCC long connection.

(2) For the results which comes from FCC, fcc_agentd is responsible for protocol conversion, and then send it to scheduled.

(3) For the data which send by FCC automatically, fcc_agentd is responsible for invoking scripts to put data into database and write the error log to the log file.

4. scripts

The purpose of scripts are parse or constructe JSON, put data into database and invoked by pos_agentd, schedule and fcc_agentd

2.4. Development Architecture

(1) directory organization

/root/gks_test/gks_bin store executable files, such as pos_agentd, fcc_agentd, scheduled, fcc_simulator, schedule get and fcc get.

/root/gks_test/gks_conf store config files, such as pos_agentd.conf, fcc_agentd.conf and scheduled.conf

/root/gks_test/gks_logstore log files, such as pos_agentd.log, fcc_agentd.conf and scheduled.conf

/root/gk_test/gks_pid store pid files

/root/gks_test/gks_script store script files mainly include command script, such as fcc_command and pos_command

/root/gk_test/gks_src store source code

/var/www/html store php files

(2) third-party library

□ json-c

□ libmysqlclient

Libiconv

3. System Function Analysis

In order to analysis the function of the system, we first introduce the business transactions of gas station, which is very important to realize the functions of the system. We classify each transaction process into five states, and details of how to process commands is shown in Figure 4.

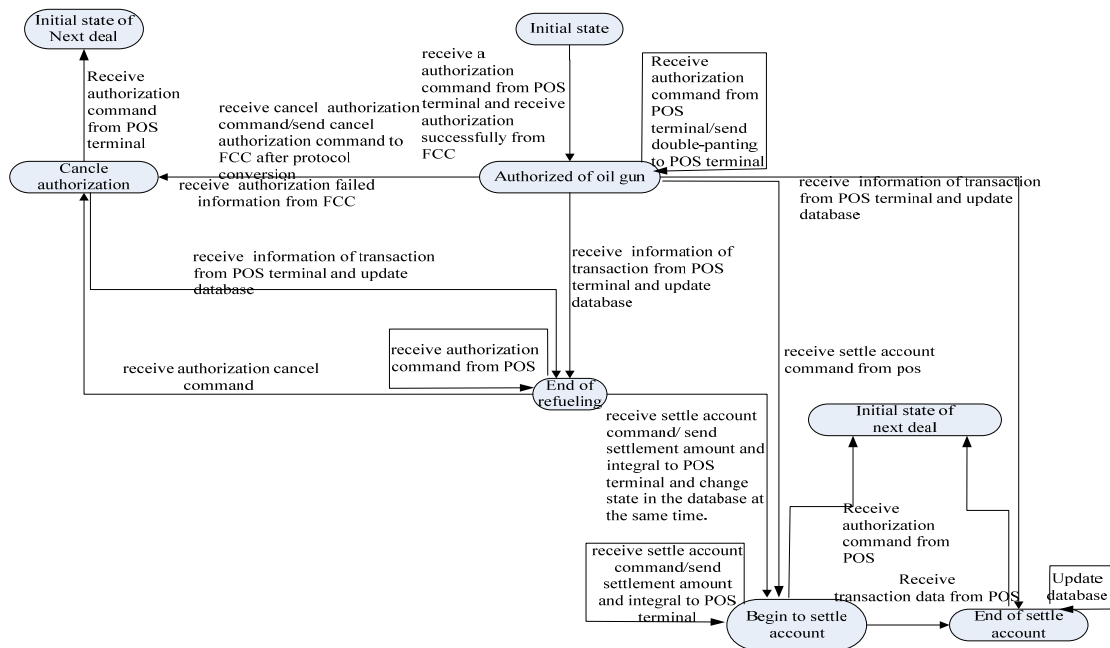

Figure 4. The State Transition Diagram of Business

The transaction state include initial state, authorized of oil gun, end of refueling, begin to settle account, end of settle account and cancel authorization of oil gun.

(1) Initial state: in this state, the information of oil gun is not exist in the database, and if now receive a authorization command from POS terminal, system will send the command to FCC after protocol conversion and then insert new records into the database. If receive authorization successfully from FCC, turn to next state.

(2) Authorized of oil gun: in this state, if receive a authorization command from POS terminal, system will send double-panting to POS terminal, if receive a cancel authorization command, system will send cancel authorization command to FCC after protocol conversion and still hold this state, if receive a authorization failed information from FCC, system will send authorization failed to POS terminal.

(3) End of refueling: in this state, if receive authorization command from POS terminal, system will send "have not settle account yet" to POS terminal, if receive settle account command system will send settlement amount and integral to POS terminal and change the information of state in the database at the same time.

(4) Begin to settle account: in this state if receive a authorization command from POS terminal, system will send the command to FCC after protocol conversion and then insert new records into the database. If receive the information of transaction from POS terminal, will turn to next state.

(5) End of settle account: in this state if receive a authorization command from POS terminal, system will send the command to FCC after protocol conversion and then insert new records into the database and this state will hold on.

Implementation of all the functions must be based on the state transition diagram. The functions can be concluded as follows:

(1) Process business and data between POS and PC or FCC and PC, for some important data, save them to the database.

(2) For pos terminal:

Receive authorization command, send complete information of oil gun and calculate different discount based on different user card, send fundamental data, save the record of sign in/sign out and transaction information.

For FCC:

Send authorization command correctly, receive present transaction data or history record, Send change price command, stop refueling command, open/close oil gun command and so on,

(3) real-time monitoring of oil gun and transaction data, users can overview all of state of the oil guns and the latest transaction record.

4. Relevant Key Technology

4.1. Protocol Conversion

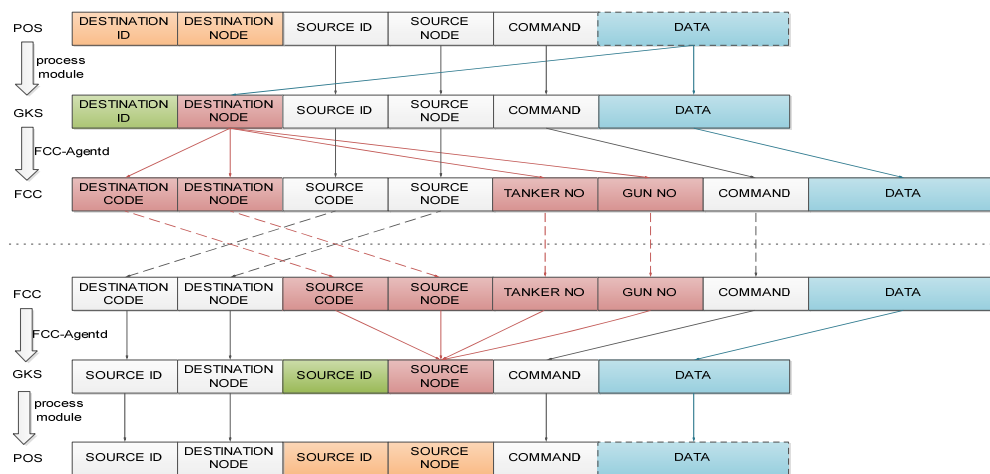

Figure 5. Protocol Conversion

Because of different protocol of POS terminal and FCC, so we need to consider protocol conversion. Both POS and FCC send command in the format of JSON, the structure of them are different.

When pos terminal send command to FCC, GKS have to do protocol conversion. The process is shown as follows:

POS agentd receive the packets from POS (JSON-POS) and then send the packets to corresponding module, this module will do a series of processing steps and then send new JSON packet (JSON-GKS) to scheduled, scheduled will send the new JSON packet to FCC-Agentd, FCC-Agentd need to parse the contents of the packet (JSON-FCC) and then send it to FCC, we can visualise the process as (JSON-POS) → (JSON-GKS) → (JSON-FCC) . Similarly, response from FCC will be (JSON-FCC) → (JSON-GKS) → (JSON-POS) .

4.2. Real-time Monitoring Technique

In this system, real-time monitoring [8, 9] can be implemented with AJAX technology and Caching technology.

(1) AJAX technology

Ajax works like this: add a middle layer between client and server, make the user operations and server response asynchronous. requests from client will be done by ajax engine, and ajax engine will submit the request to server.

The main components of ajax technology are JavaScript, XMLHttpRequest and DOM. In traditional ways of interaction [10], client send a request to server, and result are sent back from the server, so users might have a long wait before they see anything happen, so user experience was bad. This problem can be solved by ajax technology. The biggest advantage of ajax is that users can get what they want without page refresh, this benefits from XMLHttpRequest and XMLHttpRequest.

In this system, the data information of oil gun and trading will be sent to server by XMLHttpRequest object, server returns a response, and then refresh pages by DOM, we can also configure update interval.

(2) Caching technology

In practice, the transaction data of oil gun change very frequently, if we store these kind of information into RDBMS and fetch them from it, this will degrade database performance, so we choose memcached. Memcached is designed to store information in memory, it normally runs as a daemon in the background when started and accept connections from the client at any time. When a client has connected, it can access object and every object has a unique key, you can get you want with this key. For the objects are stored in memory. So use memcached can be quickly and efficiently.

We get the information of oil gun such as price, oil product, pump, amount from memcache with ajax technology. Facts proved that they worked well, user get good results from Web browsers, the following picture is the snapshot of actual operating situation from gas station, when the oil gun is pumping oil, the colour will turn to green.

| Oilgun no | State | Type | Price | Liter | Amount |
|-----------|-------|------|-------|-------|--------|
| 1 | 空闲 | 93# | 7.49 | 13.35 | 100.00 |
| 2 | 空闲 | 97# | 7.92 | 12.63 | 100.00 |
| 3 | 加油 | 97# | 7.92 | 45.97 | 364.08 |
| 4 | 空闲 | 93# | 7.49 | 9.50 | 71.16 |
| 5 | 空闲 | 93# | 7.49 | 60.46 | 452.85 |
| 6 | 空闲 | 97# | 7.92 | 45.10 | 357.19 |
| 7 | 未知 | | | | |
| 8 | 空闲 | 93# | 7.49 | 26.70 | 200.00 |
| 9 | 未知 | | | | |
| 10 | 空闲 | 0# | 7.32 | 37.00 | 270.84 |
| 11 | 空闲 | 0# | 7.52 | 50.00 | 376.00 |
| 12 | 空闲 | 93# | 7.69 | 33.81 | 260.00 |

Figure 6. The Interface of Oil Gun Monitoring

5. Database Design

Good database design is very important for a high performance system. In the designing of this system we choose mysql.

5.1. Database Choices

The reasons we choose MYSQL are the following:

(1) MySQL has powerful features, it integrate stored procedures, view, subquery, it also support full-text indexes, copy, query cache and other advanced features, and it contains rich configuration options

(2) The database management system is an open source system and to use this kind of database will reduce the costs which is very important to small to medium-sized businesses.

(3) MYSQL can be used conveniently, it runs on a wide variety of platforms MYSQL combines PHP, C, C++, JAVA perfectly.

5.2. Structure Design of Database

For there are too many tables built during the develop of this system, so we mainly introduce several important tables, and the entity-relationship diagram of these tables are shown as follows:

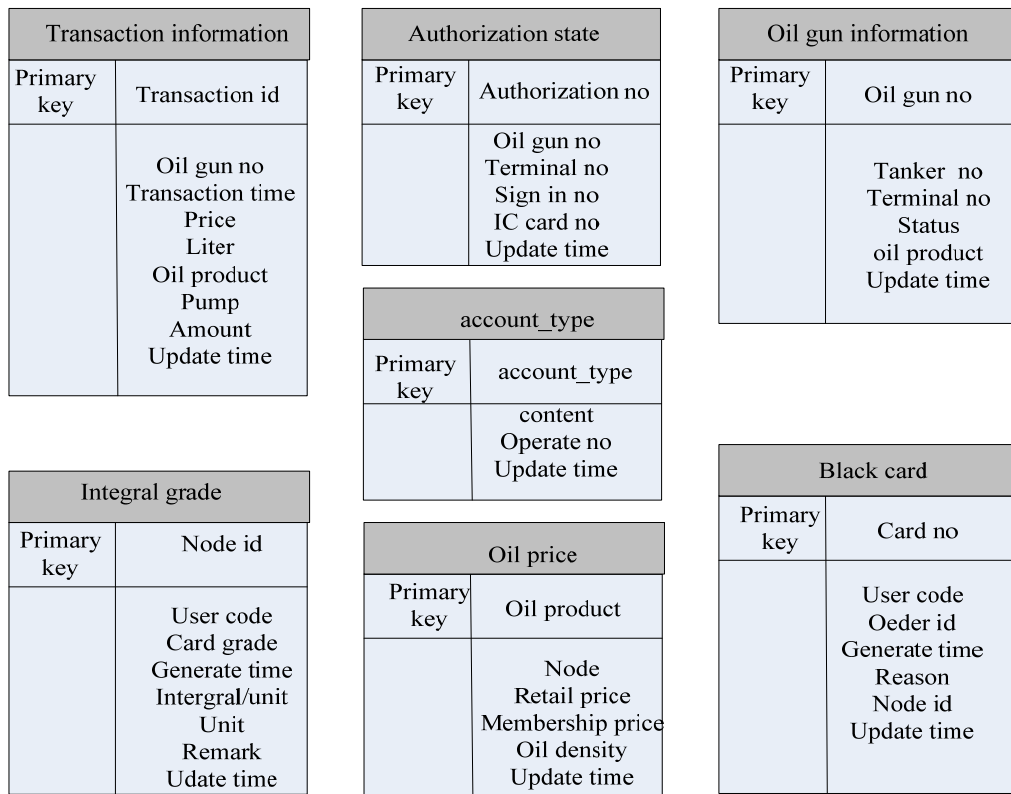

Figure 7. The Entity-relationship Diagram of Database

6. Conclusion

In this paper, we mainly introduce a management system which based on IC card and we describe the transaction model of gas station in detail. The system realized the function of sign in/sign out and authorization of employee. pos terminals can get the information of uses' IC card automaticly and act accordingly. For FCC, the system can also realize the relevant functions through transmitting protocol. Especially we design a real-time monitoring interface which greatly facilitated management personnel of of gas station. The system has been operated in gas station for more than half a year, practices show that the system is stable and

has good utility and is characterized by real-time performance and flexible expansibility, so this system is important for improving the overall management of gas station, and has bright application future.

Acknowledgements

This work was supported by the National Nature Science Foundation of China(61272306), the Important Science and Technology Special Project of Zhejiang Province (2011C11041), the Public Project of Science and Technology Plan in Zhejiang Province (2012C21001), the Public Project of Science and Technology Plan in Zhejiang Province (2013C31042), the College Students' Science and Technology Innovation Activities Plan of Zhejiang Province (1130JQ4212058G).

References

- [1] Liang Zhihong, Lu Jun. Design on Information Management System of Gas Station. Fifth International Conference on Intelligent Computation Technology and Automation. 2012: 139-141.
- [2] Zhen Ran, Zhu Wei-lu, Yang Guo-fu. Design of Central Monitor &Control System in the Refuelling Station. *Jiangsu Electrical Apparatus*. 2006 (4): 11-13.
- [3] Song Hongwei, Zhen Ran. Design and Realization of Gas station Central Control System. *Microcomputer Information*. 2006; (16): 106-107, 149.
- [4] Zhang Zongren, Zhang Luguo. The Design of Computer Concentrating Control System in Fighter Plane Service Station. *Microcomputer Information*. 2001; (05): 14, 19.
- [5] WANG Jian, LIU Yanheng, DONGTianzhe. *Design and Implementation of WPKI-based Gas Station Online Payment System*, 29th Chinese Control Conference. 2010: 4132-4135.
- [6] Ren Xuhu, Cai Lijuan, Yang Lei. Research and realization of forecourt controller at gas station. *Industrial Instrumentation & Automation*. 2010; (3): 39-44.
- [7] Weihua Xiong. Design on Self-service System of Gas Station which Based on IC Card. *Science & Technology Information*. 2009: 78.
- [8] Xuefeng Liu, Jing Zhu, Jianhua Mao, Xiaoming Shao, Longlong Lu. Design of Real-time Communication Adapter for Different Protocol Sensors in Sensor Web. *TELKOMNIKA Indonesian Journal of Electrical Engineering*. 2012: 1101-1105.
- [9] Lijing Zhang, Wei Xiong, Xuehui Xian. Research on Web-based Real-time Monitoring System on SVG and Comet. *TELKOMNIKA Indonesian Journal of Electrical Engineering*. 2012: 1142-1146.
- [10] Weiguo Han, Liping Di, Peisheng Zhao, Xiaoyan Li. *Using Ajax for Desktop-like Geospatial Web Application Development*. 17th International Conference on Geoinformatics. 2009.