

Optimal Analysis on Reactive Capacity of Control Winding for Dual Stator-Winding Induction Generator

Yu Jinyong*, Zhang Kai, Jiang Jing, Zhang Shutuan, LIU Lingshun

Department of control Engineering, Naval Aeronautical and Astronautical University, Yantai 264001, China

*Corresponding author, e-mail: tothelast@163.com

Abstract

The minimizing to reactive power of control winding of the dual stator-winding induction generator is key optimization of the novel generator system. It is determined by parameters of machine, load, rotating speed and speed range and exciting capacitors paralleled with the output terminal of power winding. In this paper, Based on analysis on working principle of conventional three-phase induction generator excited by capacitors with variable load and variable speed, the determination of excited capacitors to minimize the reactive power of control winding under variable load and speed is proposed, the control law of optimal excited current is presented.

Keywords: dual stator-winding machine, controlled winding, reactive power, optimal

Copyright © 2014 Institute of Advanced Engineering and Science. All rights reserved.

1. Introduction

The rapid consumption of traditional energy sources makes the mini-hydro, wind and other renewable energy sources has become very important. Induction motor has the highly competitive field because of its unique advantages [1-3]. The traditional self-excited induction generator in parallel at the output capacitor can provide reactive power excitation, but not suitable for the occasions of changing speed and load. Some improvement methods such as static var compensation method or Saturated reactor methods ,etc., will increase the system size, weight or injected harmonics, limiting the widespread application of the system [4].

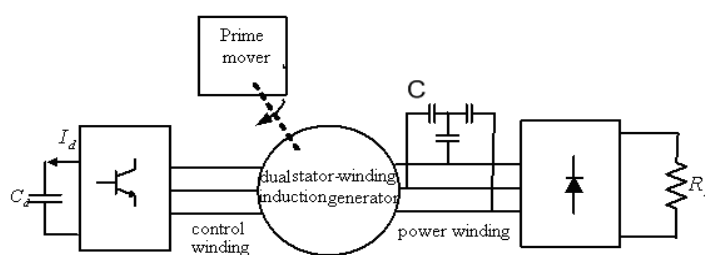

Figure 1. Dual Stator-winding Induction Generator System with Static Excited Converter

In recent years, a novel dual stator winding induction generator system based on static excitation regulator which can improve the defects of the three-phase induction, can provide a new way for renewable energy, aviation power system (Figure 1) [5-7].

There are two windings in the stator, one is power winding, which is connected rectified load. The other is control winding, which is connected static excitation inverter, it only supplies the reactive power, and none of the active power. In order to meet demands of small size, light weight requirements, and reduce system cost for the variable speed range system, PWM excitation regulator must make the size, weight minimum. As the compensation capacity has great relationship with machines parameters, load, prime mover speed and its range, excitation capacitors. In this paper, the traditional three-phase induction generator with excitation capacitance of the speed change operation mechanism is set to proceed, a systematic study of

control winding capacitance current law is presented for the dual-winding induction generator with resistance load in the rectifier and variable speed operation corresponding to different excited capacitor, and optimization methods for reactive capacity minimizing is proposed.

2. Reactive Capacity Distribution Law of Three-phase Induction Generator Excited Capacitor

Speed range is 1:3. load range is no-load to rated load. The output voltage and power are both rated. The machine parameters are PN=18KW, UN=115V, IN=52.17A, $f=134Hz$, $R_1=0.066\Omega$, $R_2=0.039\Omega$, $R_m=0.455\Omega$, $X_1=0.211\Omega$, $X_2=0.159\Omega$, $X_m=7.391\Omega$.

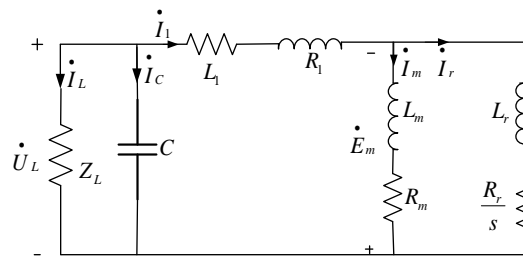

Figure 2. Equivalent Circuit of Three-phase Generator

The minimum required excitation capacitor value of induction generator running at a speed when no load is [4], [8-10]:

$$C_{0min} = \frac{1}{\omega_1^2 L_{11}} = \frac{1}{\left(\frac{pn}{9.55}\right)^2 L_{11}} \tag{1}$$

Where, p is pole pairs, n is synchronizing speed. $L_{11} = L_1 + L_m$.

The unsaturated magnetic circuit should be designed under rated generator speed state. To meet the active and reactive power balance, the calculation of excited capacitance with variable load can be drawn under different load shown in Figure 3.

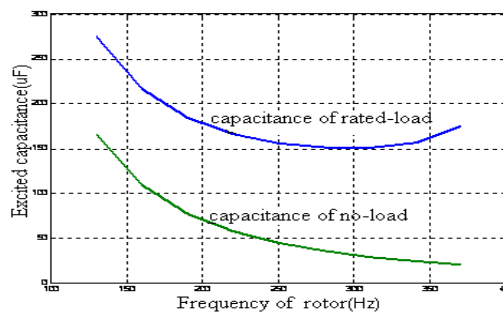

Figure 3. Minimizing Excited Capacitance

Figure 3 shows the minimum no-load excitation capacitor decreases with increased speed, mainly because slip is approximately zero under no-load, and the rotor current is zero, while the generator excitation reactive decline with the increase of speed maintaining the terminal voltage without changing.

The concave of first decreased and then increased with the increase of speed for excited capacitor C is shown with rated load. For the following reasons: excitation reactive power capacity decreased with the speed increased, reactive power of stator and rotor leakage reactance increase with the speed increases. With an increase in speed of the beginning of a very short rising phase, reduced the capacity of reactive power excitation accounts for the main factors, the generator need to reduce the total reactive power, thus capacitance decrease and the amplitude rapidly decrease and its reactive power. then the stator and rotor leakage reactance reactive start to become major factor , the total reactive power needed by generator slowly increase with the speed increased. so that C still need to slowly decrease, to enable it to provide the reactive power is also rising slowly to meet the generator's reactive power balance. When the high speed to a certain extent, the reactive power of stator and rotor leakage reactance quickly increase, the increase degree of total reactive power required by generator increase rapidly, excited capacitor need to increase to meet the demand and the corresponding stator and rotor current also need to increase.

Under rated load and 1:3 speed range, the minimal and max value of excited capacitor is respectively $C_{10} = 150\mu F$ and $C_{1m} = 275\mu F$. Under no-load, the minimal and max value of excited capacitor is respectively $C_{00} = 18\mu F$ and $C_{0m} = 165\mu F$. Thus $C_{00} = 18\mu F$ is the minimal value of the whole ranges and $C_{1m} = 275\mu F$ is max value.

3. Excitation Control Optimization of Dual Stator-winding Induction Generator

Analysis can be seen from Figure 3, when the induction generator speed and load change, if reactive power excitation is providing by only capacitance C, then C must be changing to meet the needs of the generator's reactive power, which is obviously not feasible for the system implementation. Capacitor C is actually fixed, then the system reactive power demand changes can be compensated by control winding. Capacitance C values is essential for the reactive capacity changing in a certain operating conditions. In order to control the winding to minimize reactive power capacity, is need to be optimized for this study.

When the excitation capacitor is constant, the known motor parameters, speed, load and output power, the control winding to provide current to the equivalent circuit can be calculated uniquely, so control can be seen as a current source branch. In order to explore the winding two-winding induction generator reactive power control mechanism of the smallest capacity in the control winding plus a current source on the slip road, which was controlled with the leakage inductance and winding resistance and current may be used to control the positive and negative PWM converter slip energy flow, is positive that the motor slip compensation control capacitive reactive; is negative, indicating the motor reactive power flow control by the motor slip

When the excitation capacitor is constant, and generator parameters, speed, load and output power are all known, the control winding current can be calculated uniquely from the equivalent circuit, so control winding can be seen as a current source branch.

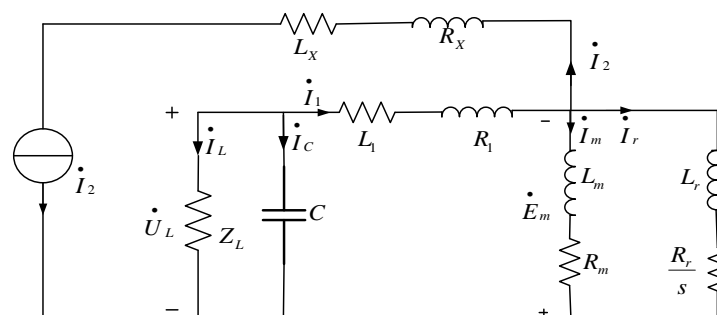

Figure 4. Equivalent Circuit of Dual-winding Induction Generator Plus External Current Source

In order to explore minimal mechanism of control winding reactive power, a current source branch is plus in the control winding. Where, L_x and R_x is respective the leakage inductance and winding resistance. The positive and negative value of \dot{I}_2 may be used to show energy flow of control PWM converter, \dot{I}_2 is positive that the capacitive reactive is compensated for generator, and \dot{I}_2 is negative indicating the generator reactive power flow to control branch. Capacitance values of C should be achieved \dot{I}_2 minimum within the entire operating range.

Firstly, the variation laws of the control winding branch current with capacitor C in the following two values are researched. One is $C_{00} = 18\mu F$, and the other is $C = 0.5(C_{00} + C_{1m})$

3.1. The Influence on the Control Winding Branch by Excited Capacitor

The currents I2 of $C = 18\mu F$ and $C = 0.5(C_{00} + C_{1m}) = 146\mu F$ with 1: 3 speed range are shown as:

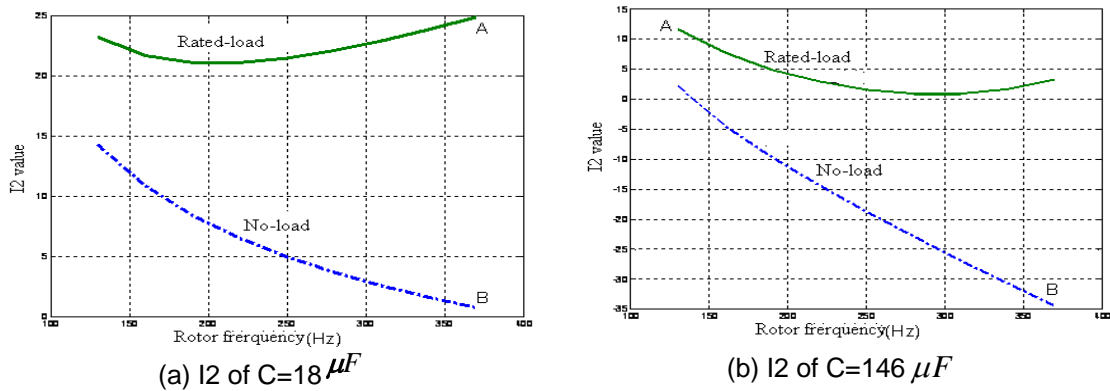

Figure 5. The Laws of Different C

Control branch current maximum range in the entire running are: the 25A of rated load point A with $C_{00} = 18\mu F$ and the ratio with rated output current 52.15A is 48%. The -35A of no-load point B with $C = 146\mu F$ and the ratio with rated output current 52.15A is 67%. From the above chart, shows that the greater capacitance C is good to reduce capacitive current of control branch with the rated load, but can increase the inductive current of control branch with no-load. The current $\left| \dot{I}_2 \right|_{\max}$ is not the minimal.

3.2. Optimizing to the Control Branch Current I2

The maximum control winding currents are high in both cases above and the capacity of converter will be very high. Need to further adjust the C, to make inductive current maximum and capacitive current maximum provided by the current source equal. Then it can make the control branch current I2 is the smallest in the entire running range, which is selected by C to optimize the value of the smallest value control winding current. The optimal values are shown as Figure 6.

1) Optimized $C = 80\mu F$, then maximum absolute value of I2 in the rated load and no-load are both 17A (figure A, B point), and the ratio with output current is 32%, which can reduce converter capacity to 1/3 less of output rated capacity. Therefore, $C = 80\mu F$ is the optimal excitation capacitance.

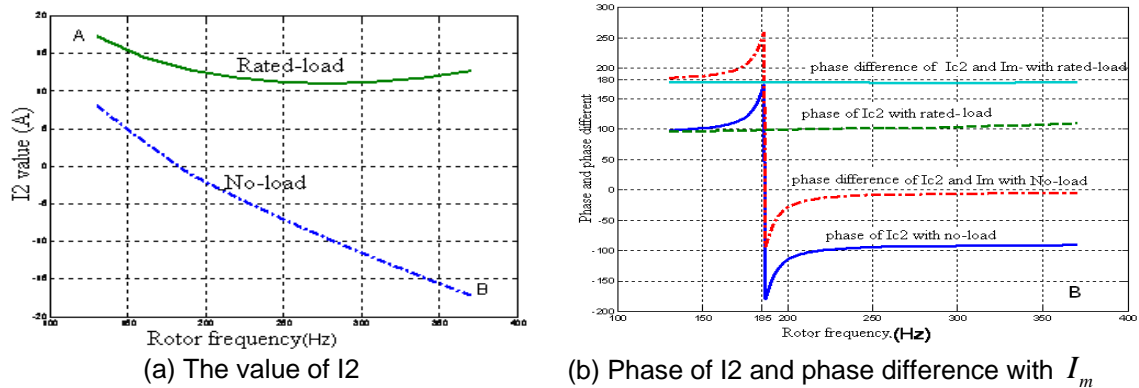

Figure 6. The I_2 Value of Optimal $C=80\mu F$

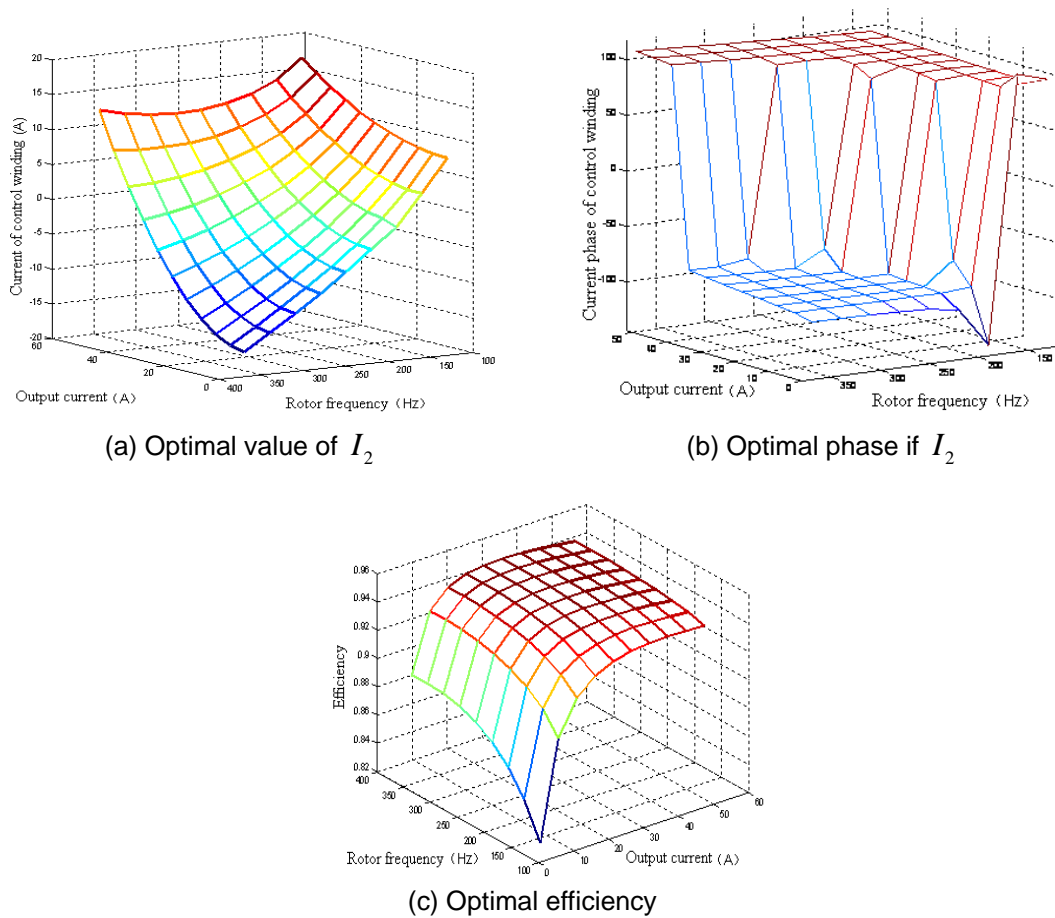

Figure 7. Optimal I_2 and Efficiency with Variable Speed and Load

2) When only excitation capacitor excited to the system with no-load, the known changes range of C is $165-18\mu F$ and the optimized value is $C = 80\mu F$. When low speed, reactive power provided by C can not fully meet the demand for reactive power of the generator, thus the control branch will provide capacitive reactive power, expressed as the current I_2 is positive. When the rotor frequency increasing to the 185Hz , the $C = 80\mu F$ will provide more reactive power than necessary of the generator, then control branches provide inductive reactive to the generator, the performance of the current I_2 is negative.

Under rated load, the control branch current is always positive, indicating the I_2 capacitive and showed the concave of decreases firstly and then increases (Figure 6(a)).

Figure 6(b), The phase angle of I_2 with no-load transition from about 95° to about 95° (to the power winding phase AC output voltage as a reference), that control wind providing the reactive power to the generator changes to absorb reactive power from the generator. And in both cases, the phase difference between I_2 and I_m is approximate 0° or 180° , which shows control winding current is essentially reactive component.

3.3. Current Law of Optimal Control Winding

In Figure 4, the control \dot{I}_2 must be based on two factors of speed and load, follow the curve of $I_2 - \omega$ and the curve of $I_2 - \text{load}$ to obtain the composition of the three-dimensional surface (magnitude and phase, Figure 7). I_2 is the minimum to ensure the control winding capacity of the inverter minimum.

4. Conclusion

In this paper, the determination of excited capacitors to minimize the reactive power of control winding under variable load and speed is proposed, the control law of optimal excited current is presented. The influences of machine's parameters are analyzed. Obtained the conclusion of generator design must reduce the stator and rotor winding leakage reactance, magnetizing inductance to suitably increase the capacity to reduce the control winding.

References

- [1] RH Nelson, PC Krause. Induction machine analysis for arbitrary displacement between multiple winding sets. *IEEE Trans on PAS*. 1973; 93(2): 841-848.
- [2] Huang Wenxin. Research on high voltage DC generation system based on squirrel-cage induction generator and power electronic converter [PhD dissertation]. Nanjing University of Aeronautics & Astronautics. 2002.
- [3] Muljadi E, Lipo TA. Series compensated PWM inverter with battery supply applied to isolated induction generator. *IEEE Trans on Industry Application*. 1994; 30(4): 1073-1082.
- [4] Singh B, Shilpakar LB. *Analysis of a novel solid state voltage regulator for a self-excited induction generator*. IEE Proc. Gener. Trans. Distrib. 1998; 145(6): 647-655.
- [5] Wang Dong, Ma Weiming. *Research on dual stator-winding induction generator with static excitation regulator*. Proceedings of the CSEE. 2003; 23(7): 145-150.
- [6] Lorunfemi Ojo, Innocent Ewean Davidson. PWM-VSI Inverter-Assisted Stand-Alone Dual Stator Winding Induction Generator. *IEEE Trans. On Industry Applications*. 2000; 36(6): 1604-1611.
- [7] Liu Lingshun, Hu Yuwen, Huang Wenxin. Optimization to Reactive Capacity of Control Winding of Dual Stator-Winding Induction Generator Operating with Varying Speed and Varying Load. *Transactions of China Electrotechnical Society*. 2006; 21(3): 94-99.
- [8] Huang Tao, Ruan Jiangjun, Zhang Yujiao, etc. Magneto-structural coupling field analysis on the end winding of a multiphase induction machine. *TELKOMNIKA Indonesian Journal of Electrical Engineering*. 2012; 10(5): 933-939.
- [9] Reza Lika, S Asghar Gholamian. Optimum design of a five-phase PMSM for underwater vehicles by use of PSO. *TELKOMNIKA Indonesian Journal of Electrical Engineering*. 2012; 10(5): 925-932.
- [10] SSQ Chen. *Electrical machine design*. The Publishing House of Machine Industry. 2002.