

Automatic Voltage Generation Control for Two Area Power System Based on Particle Swarm Optimization

Ali M Ali^{*1}, MA Ebrahim², MA Moustafa Hassan³

¹Cairo North Power Station, Ministry of Electricity and Energy, Egypt

²Electrical Engineering Department, Faculty of Engineering (Shoubra), Benha University, Egypt

³Department of Electrical Power and Machines, Faculty of Engineering, Cairo University, Egypt

*Corresponding author, e-mail: eng.ali_mohammed@hotmail.com

Abstract

This article presents a PID controller for two area power system equipped with both automatic generation control and automatic voltage regulator loops. The research has been done to control two area power systems with PSO optimized self-tuning PID controller. The comparison between different controllers and the suggested PSO based controller illustrates that the proposed controller can generate the best dynamic response for a step load change. For this purpose, MATLAB-Simulink software is used. The obtained results are promising.

Keywords: automatic generation control (AGC), automatic voltage regulator (AVR), evolutionary computation (EC), particle swarm optimization (PSO), two area power system, load frequency control (LFC)

Copyright © 2016 Institute of Advanced Engineering and Science. All rights reserved.

1. Introduction

The growing on electricity demand will cause increasing load change. When the load on the grid raised, the speed of turbine is decreased before the governors can take an adjustment action to adjust the input of steam to the new load. As the change in the value of speed decreased, the error signal becomes smaller and the position of the governor flyballs gets closer to the point necessary to maintain a constant speed.

There are two reasons against allowing the frequency to deviate extremely much from its standard value. A non-standard frequency in the system causes a poorer quality of the delivered electrical power. Many of the devices that are connected to the system work better at nominal frequency as explained in [1].

Many discussions have been carried out in the past to treat with Load Frequency Control (LFC) problem. In literature, some control policies have been discussed based on the conventional linear control theory [2].

These two control signals (ΔP_c and ΔP_{tie}) are improved, mixed and transformed to a real power signal, which then controls the governor position. Depending on the governor position, the turbine changes its output power to establish the real power balance [1]. The automatic control system consists of two major parts, the primary and secondary control. Ternary control is manually activated close to the electricity production according to generations schedules (dispatch) as discussed in [3].

The most common ways used to achieve frequency control are generator governor response (primary frequency regulation) and LFC. The task of LFC is to restore primary frequency regulation capacity, bringing again the frequency to its predefined value and reduce unscheduled tie-line power flows between neighboring control areas. From the mechanisms used to handle the economic of this service in additional markets, the common contracts or competitive offers stand out [4]. The normal speed will not be the set point due to primary controller, and there will be an offset. One method to restore the speed or frequency to its supposed value is to add an integrator. The integral part observes the average error over a period of time and will defeat the offset. This scheme is done manually through the Load Frequency Control (LFC) or Automatic Generation Control (AGC) [5, 6] as shown on Figure 1.

In general AGC is a control system with three main items as mentioned below:

- 1) AGC is a control system with three major things as mentioned below: Preserving system frequency in its supposed value or a value close to it.
- 2) Preserving every unit generation in an cost-effectively proper value.
- 3) Preserving correct value of power transfer between areas.

Common LFC systems are designed with Proportional-Integral (PI) controllers [7]. However, since the “I” control parameters are usually tuned; it is incapable of obtaining good dynamic performance for various load and system changes.

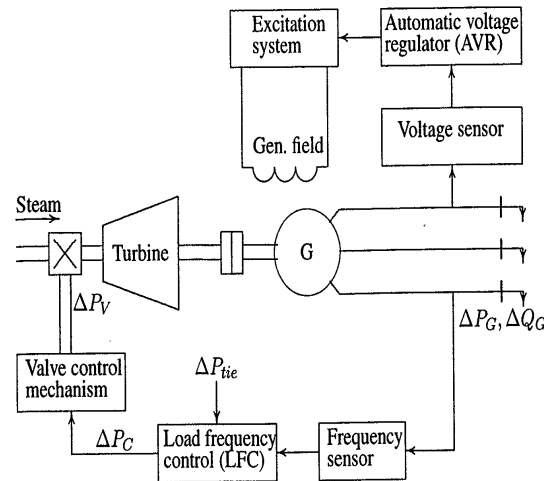

Figure 1. Schematic Diagram of LFC and AVR of a Synchronous Generator

In the integral controller, if the integral gain K_i is very high unacceptable large overshoots will be occurred. Though, adjusting the maximum and minimum values of proportional (K_p), integral (K_i) and derivative (K_d) gains respectively, the outputs of the system (voltage, frequency) could be improved as stated in [8].

The Generation Rate Constraint (GRC) is taken into account by adding a limiter to the turbine and also by adding to the integral control part to prevent excessive control action [9]. It is assumed that generating units belonging to the same type of generation will have the same GRC. The results in references [10-11] indicate that the GRC would significantly influence the dynamic responses of power systems. In the case where GRC is presented, the system will show larger overshoots and longer settling times, compared with the case where GRC is not considered [12].

Stability and reliability of nominal voltage level in an electric power grid is one of the main problems for an electric power system control. It is possible to minimize the real line losses by controlling the nominal voltage level. Nowadays, Automatic Voltage Control (AVR) is generally applied to the power generation units in order to solve this control problem as discussed in [13-14].

The aim of this control is to maintain the system voltage between limits by adjusting the excitation of the machines. The AVR senses the variation between a rectified voltage derived from the stator voltage and a reference voltage. The error signal is amplified and fed to the excitation system. The constant VAR balance in the network is offered by the change in excitation system. This technique is also referred as Megawatt Volt Amp Reactive (MVAR) control or Reactive-Voltage (QV) control [15].

The voltage of the generator is proportional to excitation (flux) of the generator. The excitation is used to control the voltage. Therefore, the voltage control system is also called as excitation control system or AVR. For the generators, the excitation is provided by a device (another machine or a static device) called exciter. Depending on the way the DC supply is given to the field winding of alternator (which is on the rotor), the exciters are classified as Direct

Current (DC) exciters, Alternating Current (AC) exciters and static exciters as discussed in [16-17]. This research uses AC power source via solid-state rectifiers, the output voltage of exciter is a nonlinear function of field voltage due to the saturatuin effects in the magnetic circuit.

The rest of article is organized as follow: Section 2 discusses the AGC including AVR system model.

Section 3 presents modeling of AGC for two-area power system. Furthermore Section 4 illustrates Evolutionary Computation while Sections 5, 6, 7 and 8 presents different types of Particle Swarm Optimization techniques. Section 9 presents the simulation results and discussion; the conclusions were driven in section 10.

2. AGC including AVR System Model

Small changes in real power are essentially dependent on changes in rotor angle δ and, therefore the frequency f . The reactive power is mainly dependent on the voltage magnitude (i.e. on the generator excitation) [15]. Change in angle δ is due to momentary change in generator speed. Thus, load frequency and excitation voltage controls are non- interacting for small changes and can be modeled and analyzed separately [15]. Moreover, excitation control is fast acting at the same time as the power frequency control is slow acting since, the major time constant shared by the turbine and generator moment of inertia-time constant is much larger than that of the generator field [15].

Since there is a weak coupling between LFC and AVR systems, the frequency and voltage were controlled separately. The AGC and AVR loops are considered independently, since excitation control of generator have small time constant contributed by field winding, where AGC loop is slow acting loop having major time constant contributed by turbine and generator moment of inertia. Thus transient in excitation control loop are scatter much fast and does not affect the AGC loop. The interaction exists but in opposite direction. Since AVR loop affect the magnitude of generated e.m.f, this e.m.f determines the magnitude of real power and hence AVR loop felt in AGC loop. When included the small effect of voltage on real power [23]. The following linearized equation is obtained:

$$P_e = P_s \Delta \delta + K_1 E' \quad (2)$$

Where

P_s is synchronizing power coefficient.

$\Delta \delta$ is change in the power angle.

K_1 is the change in the electrical power for small change in the stator emf.

$$V_t = K_2 \Delta \delta + K_3 E' \quad (3)$$

Where

K_2 is the change in terminal voltage for small change in rotor angle at constant stator emf.

K_3 is change in terminal voltage for small change in stator emf at constant rotor angle.

Modifying the generator field transfer function to include effect of rotor angle may expressed the stator emf as

$$E' = \frac{K_g}{1 + \tau_g s} (V_f - K_4 \Delta \delta) \quad (4)$$

The above constants depend upon the network parameters and operating condition.

3. Modelling of AGC including AVR for Two-Area Power Sytem

The system studied consists of two power control areas with thermal reheat unit type connected by tie-lines that allows power exchange between areas [18] as presented in Figure 2.

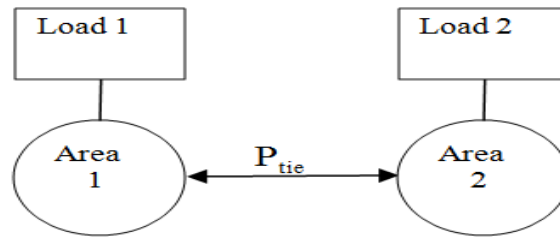

Figure 2. Two Area Interconnected Power System.

The proposed work investigates the effect of coupling between AGC and AVR.

The main aims of the multi-area power system are

- a) Reduce power system frequency deviation
- b) Interchange power within the fixed range.
- c) Control the tie-line power flow at the scheduled value determined [19].

Conventional LFC is depending upon tie-line bias control; where each area heads for minimize the area control error (ACE) to zero. The input to the supplementary controller of the i th area is the area control error (ACE $_i$) which is given by:

$$ACE_i = \sum_{j=1}^n (\Delta P_{tie(i,j)} + B_i \Delta f_i)$$

Where B_i is frequency bias coefficient of i^{th} area, Δf_i is frequency error, ΔP_{tie} is tie-line power flow error and 'n' is number of interconnected areas [20-21]. The area bias B_i determines the amount of interaction during load perturbation in neighboring area [22]. To obtain better performance, bias B_i is selected as:

$$B_i = \frac{1}{R_i} + D_i$$

Where:

R: is speed regulation.

D: is Frequency Sensitivity Load Coefficient.

4. Evolutionary Computational Techniques

Evolutionary Computation (EC) is developed from the theory of the 'survival of the fittest' obtained by Charles Darwin in 1859 and the expression of Evolutionary Computation was created as recently as 1991. It is a meta heuristic technique and a biologically motivated search and optimization method [24]. An EC technique inspired the evolutionary philosophy into algorithms that are used to search for optimal solutions to a problem. By this algorithm, a number of possible solutions to a problem are available and the task is to get the best solution. EC forms a search space which contains the randomly generated solutions and finds the optimum solution from the search space [17, 24].

One of EC techniques is the Particle Swarm Optimization (PSO).

5. Conventional Particle Swarm Optimization

PSO is a stochastic Evolutionary Computation technique based on the movement and intelligence of swarms. The main advantage of PSO suggestion when compared with GA is that

PSO does not have genetic operators such as crossover and mutation. Particles bring up to date themselves with the internal velocity and goes to converge to the best solution quickly [15-16].

The main difference between PSO and other ECs presented in how it could change the population/swarm from one iteration to the next in the search space during the whole run, whereas in EA, the individuals are replaced in each generation [25].

In PSO, the coordinates of each particle signify a possible solution associated with two vectors, the position (x_i) and velocity (v_i) vectors.

In N-dimensional search space $X_i = [x_i^1, x_i^2, \dots, x_i^N]$ and $V_i = [v_i^1, v_i^2, \dots, v_i^N]$ are the two vectors associated with each particle i .

A swarm composed of a number of particles "or possible solutions" that progress (fly) through the feasible solution space to explore optimal solutions. Each particle update its position based on its hold best exploration; best swarm overall experience, and its previous velocity vector according to the following model [24]. Equation (5) and (6) describes the PSO.

$$V_i^{t+1} = w \times V_i^t + C_1 \times R_1 \times (Pbest_i^t - X_i^t) + C_2 \times R_2 \times (Gbest^t - X_i^t) \quad (5)$$

$$X_i^{t+1} = X_i^t + V_i^{t+1} \quad (6)$$

Where :-

C_1 and C_2 are two positive constants.

R_1 and R_2 are two randomly generated numbers with a range of {0,1}

w is the inertia weight.

$Pbest_i^t$ is the best position particle achieved based on its own experience

$$Pbest_i^t = [x_{i1}^{pbest}, x_{i2}^{pbest}, \dots, x_{iN}^{pbest}]$$

$Gbest^k$ is the best particle position based on the whole swarm's experience.

$$gbest^t = [x_1^{gbest}, x_2^{gbest}, \dots, x_2^{gbest}]$$

t is the iteration index.

The term of $pbest$ is called cognitive component while the term of $gbest$ called social component so the values of C_1 and C_2 control the direction of each particles in both local and global components, the term of ($w \times v_i$) is previous velocity [16].

A large of inertia weight w at initial searching then linearly decreasing with iteration proceeded following relation as

$$w = w_{max} - \frac{(w_{max} - w_{min})iter}{iter_{max}} \quad (7)$$

Where

w_{max} is final weight, w_{min} is minimum weight.

$iter_{max}$ is maximum iteration number is maximum iteration number

This is called Time Varying Inertia Wehgit (TVIW-PSO) [27].

6. Constrictive Particle Swarm Optimization (C- PSO)

The major assumption of constriction factor-PSO is to avoid premature convergence of PSO in early stages of search and helps to escape from local optimal point then enhance the convergence of PSO algorithm [27]. By putting Constrictive factor (K) multiply on Equation (6) where it equal to

$$K = \frac{2}{\text{abs}(2-C-\text{sqrt}(C^2-4*C))} \quad (8)$$

Where $C = C_1 + C_2$, $C > 4$ [28].

7. Adaptive Acceleration Coefficients Particle Swarm

Adaptive Acceleration Coefficients Particle Swarm (AAC-PSO) is characterized by the acceleration coefficients C_1 and C_2 are changed linearly with time that the cognitive component is reduced while social component is increased as search iteration proceeds. The AAC-PSO changes the acceleration coefficients exponentially in time with respect their minimum and maximum values. The using of exponential function to increase or decrease speed of such function to accelerate the convergence process to get better search in exploration space. Also C_1 and C_2 are adaptively according to the fitness value of G_{best} and P_{best} [27].

$$V_i^{(t+1)} = w^{(t)} V_i^{(t)} + C_1^{(t)} r_1 \times (P_{best}^{(t)} - X_i^{(t)}) + C_2^{(t)} r_2 \times (G_{best}^{(t)} - X_i^{(t)}) \quad (10)$$

Where

$$w^{(t)} = w_o \cdot \exp(-\alpha_w \times t) \quad (11)$$

$$C_1^{(t)} = c_{1o} \cdot \exp(-\alpha_c \times t \times k_c^{(t)}) \quad (12)$$

$$C_2^{(t)} = c_{2o} \cdot \exp(\alpha_c \times t \times k_c^{(t)}) \quad (13)$$

$$\alpha_c = -\frac{1}{t_{max}} \cdot \ln\left(\frac{c_{2o}}{c_{1o}}\right) \quad (14)$$

$$k_c^{(t)} = \frac{(F_m^{(t)} - G_{best}^{(t)})}{F_m^{(t)}} \quad (15)$$

Where $c_i^{(t)}$ is acceleration coefficient at iteration t , with $i=1$ or 2 .

$w^{(t)}$ is inertia weight factor and t is iteration number. α_w is determined with respect to initial and final values of w with the same manner as α_c and \ln is neperian logarithm. $k_c^{(t)}$ is determined based on the fitness value of G_{best} and P_{best} at iteration t . w_o , c_{oi} are initial values of inertia weight factor and acceleration coefficients respectively with $i=1$ or 2 . $F_m^{(t)}$ is the mean value of the best positions related to all particles at iteration t as explained in [29].

8. Modified Adaptive Acceleration Coefficients Particle Swarm

Modified Adaptive Acceleration Coefficients Particle Swarm (MAAC-PSO) equation is the same as for (AAC) but it is assumed that $C_1 + C_2 = 4$ so $C_2 = 4 - C_1$. It's supposed to be less calculation for c_1 and c_2 then getting faster solutions than (AAC) as explained in [30].

9. Simulation results and discussion the test system

The case under study is two area having two machines (generator and governor) with different system parameters using PID controller for LFC model in each area and another PID

for each AVR area with including GRC, sudden drop in load (Final value) in each area is 0.01 per unit and GRC in each area is (-0.1/60) as presented in Figure 3.

Notes :

These values taken with tolerance $\pm 2\%$ of full scale.

the pso run simultaneously in both areas which mean the gains of one area related to other area to give the optimum result.

Table (1) displays the most optimal gains obtained by different types of PSO.

Area 1 parameters:

$T_{g1}=0.2, K_{g1}=1, K_{t1}=1, T_{t1}=0.5, H1=5, D1=0.6, B1=20.6, 1/R1=20, R1=0.05, K_{a1}=10, T_{a1}=0.1, K_{e1}=1, T_{e1}=0.4, K_{g1}=0.8, T_{g1}=1.4, K_6=0.5, K_5= -0.1, K_4=1.4, P_s=2=K1, K_2=0.2, K_r=1, T_r=0.05$

Area 2 parameters:

$T_{g2}=0.3, K_{g2}=1, K_{t2}=1, T_{t2}=0.6, H2=4, D2=0.9, B2=16.9, 1/R2=16, R2=0.0625, K_{a2}=9, T_{a2}=0.1, K_{e2}=1, T_{e2}=0.4, K_{g2}=1, T_{g2}=1, K_8=0.5, K_r2= 1, T_r2=0.05, a_{12}=-1.$

Area 1:

Table 1. Performance Evaluation for PID Controller tuned by Different Types of PSO for Area 1
The PID controller of AVR gains are $K_P=2; K_I=0.13967; K_D=1.$

	KP	KI	KD	Obj. Funct.	Ts (Sec)	Peak Value (ΔF)
TVIW-PSO	0.05967	100	5.2412	517.181	66.1923	0.0909
C-PSO	6.3119	44.133	8.1723	487.99	75.2692	0.0909
AAC-PSO	0.2396	12.263	10	551.5611	67.2764	0.0909
MAAC-PSO	4.9685	100	4.6664	487.987	73.2223	0.0909

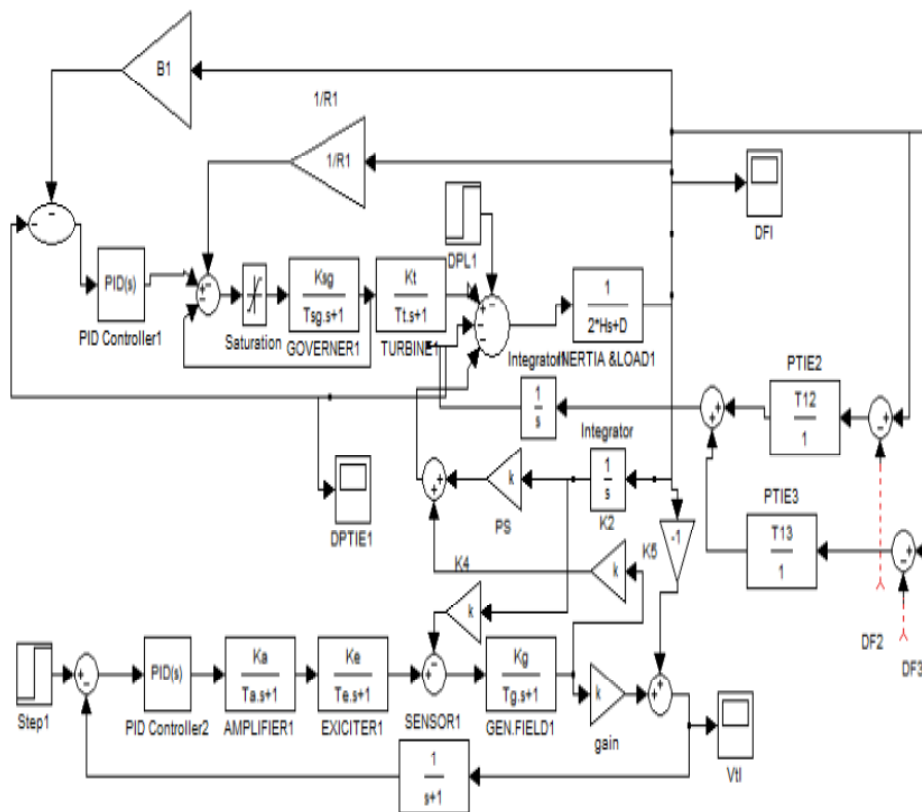

Figure 3. LFC with AVR using LFC Integral Controller.

Area 2:

Table 2. Performance Evaluation for PID Controller Tuned by Different Types of PSO for Area 2

Optm. Technique	KP	KI	KD	Obj. Fun.	Ts (Sec)	Peak Value
TVIW-PSO	9.634	48.26	9.199	517.18	61.59	0.0833
C-PSO	0.5	48.83	8.874	487.99	70.71	0.0833
AAC-PSO	15.25	36.19	7.199	551.56	62.75	0.0833
MAAC-PSO	0.340	23.74	7.312	487.98	68.63	0.0833

The PID- AVR gains are $K_P=2$; $K_I=0.13967$; $K_D=1$.

The Figure 4 depicts the frequency deviation of area 1 without using LFC and AVR controllers.

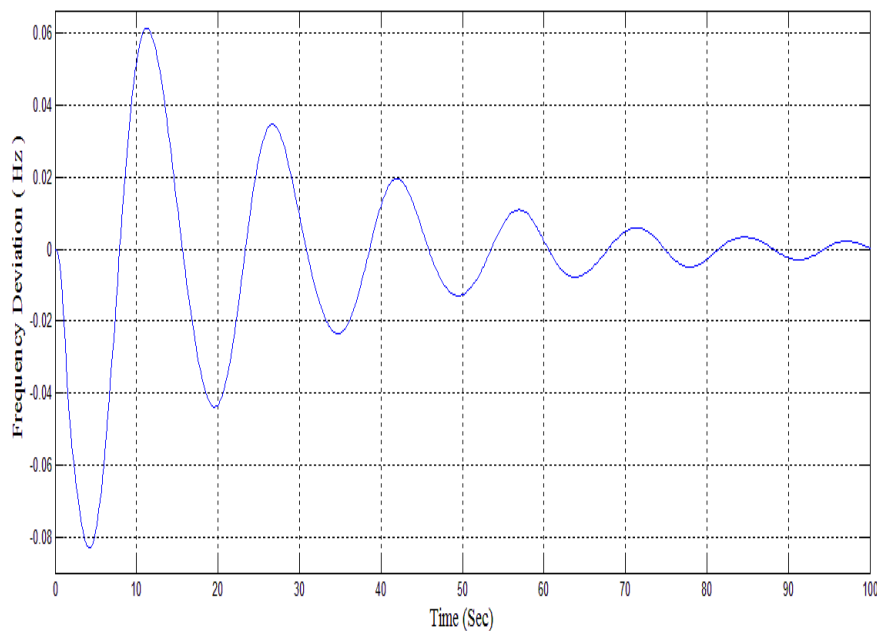

Figure 4. Frequency Deviation in Area (1) without using LFC and AVR Controllers

The Figure 5 presents the frequency deviation of Area 2 without using LFC and AVR controllers.

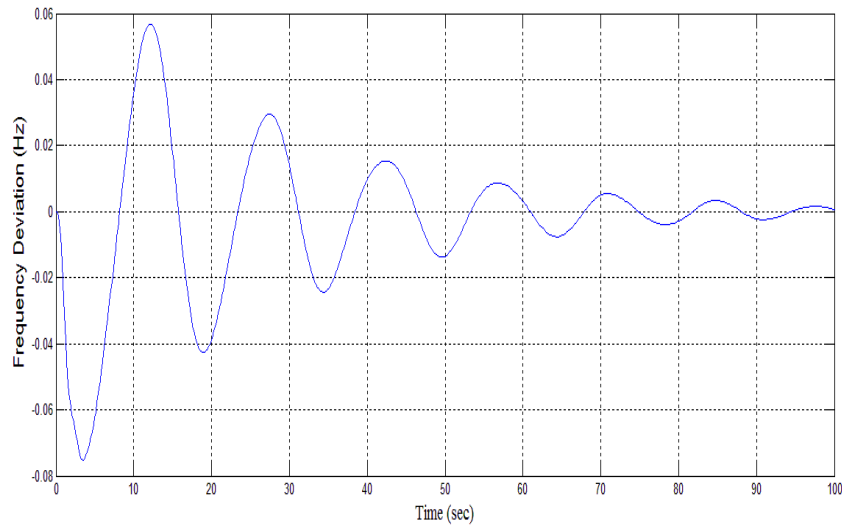

Figure 5. Frequency Deviation in Area 2 without using LFC and AVR controllers

The Figure 6 gives the comparisons between 4 gains for frequency deviation of Area 1 with PID-controller in case of using GRC.

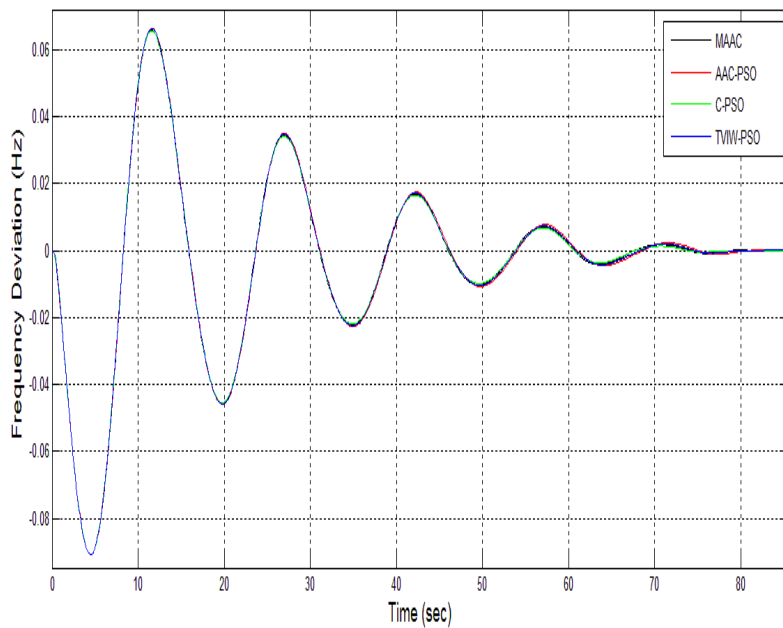

Figure 6. Frequency Deviation of Area 1 with PID controller included GRC

The Figure 7 illustrates the comparisons between 4 gains for frequency deviation of area 2 with PID-controller in case of using GRC.

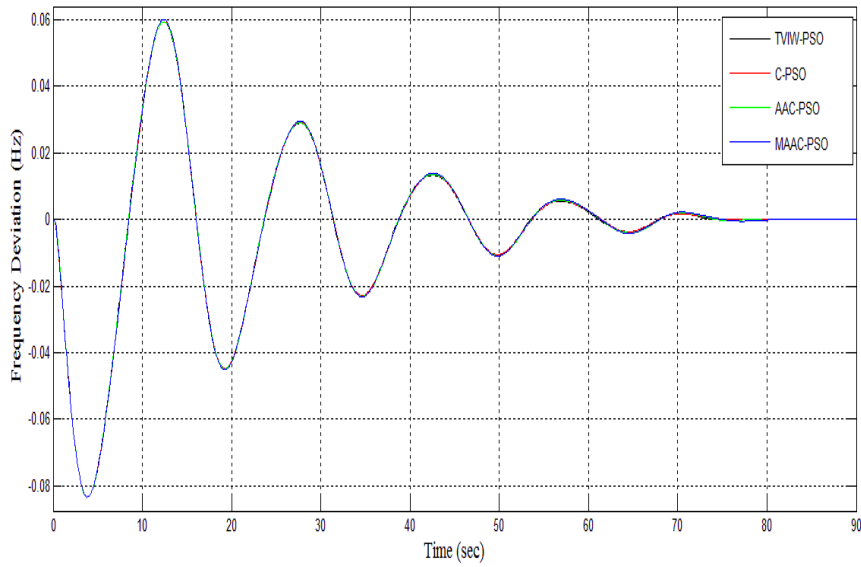

Figure 7. Comparisons between 4 gains for Frequency Deviation of Area 2

The Figure 8 presents the frequency deviation comparison between the TVIW gain and without using PID controller for Area 2.

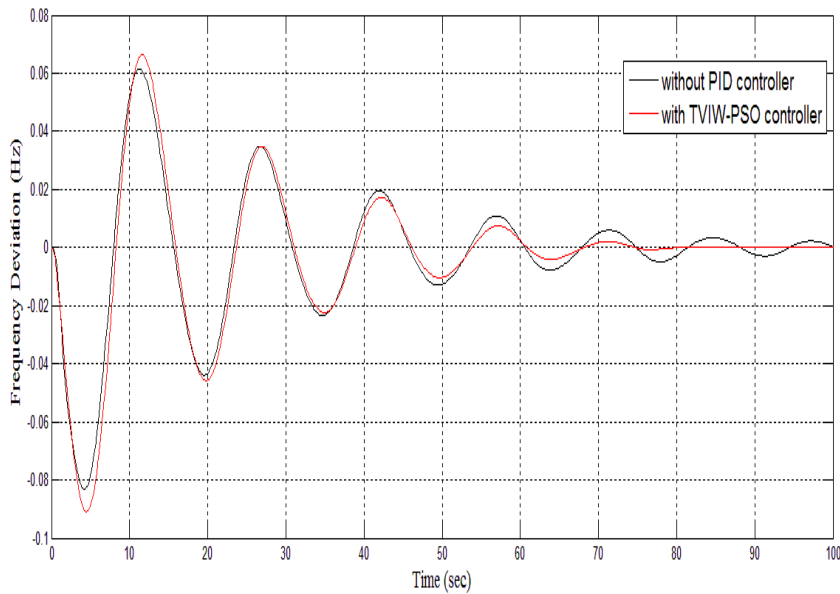

Figure 8. Frequency Deviation in Area (1) with/without using LFC and AVR Controllers

The Figure 9 gives the the frequency deviation comparison frequency Area 2 with/without using LFC and AVR controllers. The Figure 10 displays the terminal voltage response in Area 1. The Figure 11 displays the terminal voltage response in Area 2.

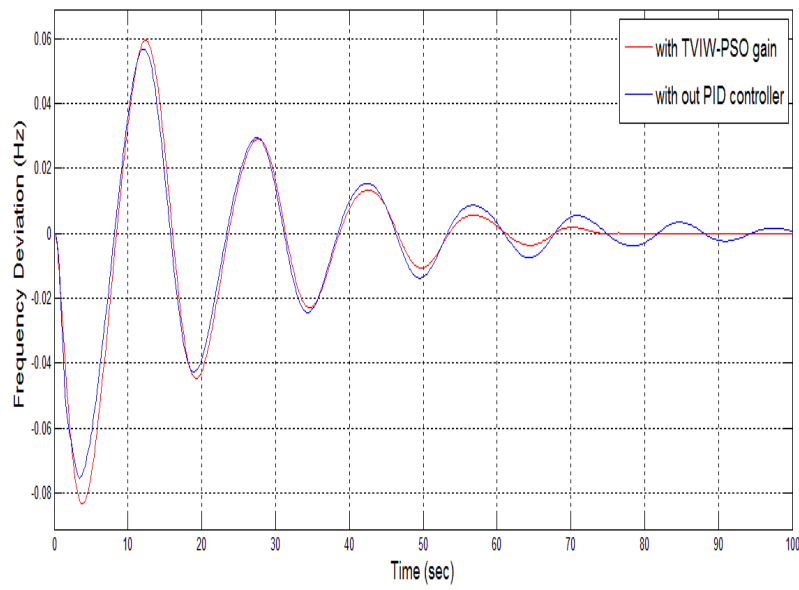

Figure 9. Frequency Deviation Comparison for Area (2) with/without using LFC and AVR controllers

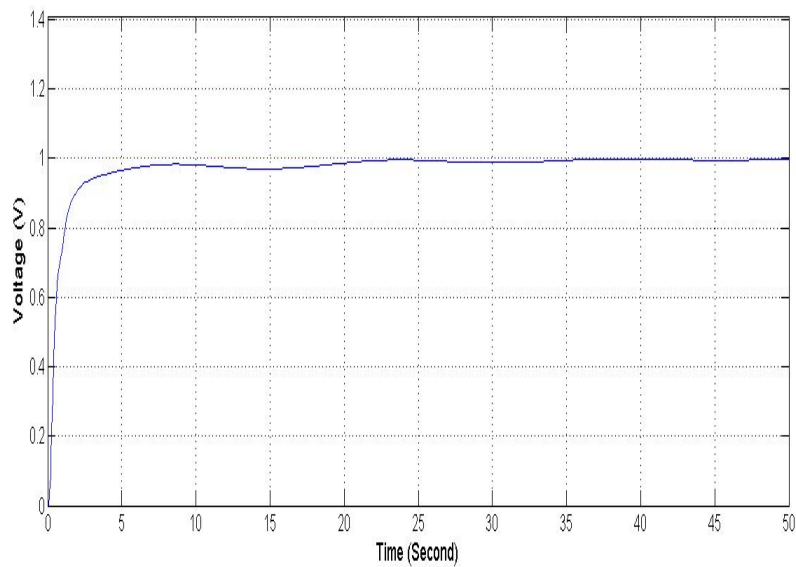

Figure 10. Terminal Voltage Step Response in Area (1)

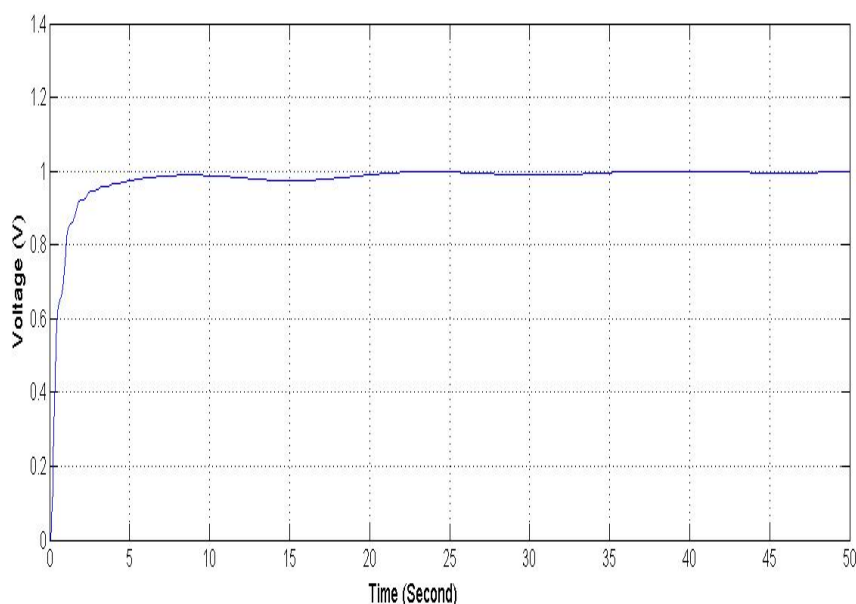

Figure 11. Terminal Voltage Step Response in Area (2)

10. Conclusion

In this article, different particle swarm optimized LFC with AVR for two area power system has been investigated. It's observed that all kinds of PSO used in this article didn't give big or obvious difference between them but eventhough, The TVIW- PSO gain gives better performance. TVIW-PSO gain gives a good improvement in performance compared to the case of No controller. Also the voltage response does not vary according to the LFC PSO gains values. This due to the fact that there is a weak coupling between LFC and AVR systems

References

- [1] Saadat, Hadi. Power system analysis. WCB/McGraw-Hill, 1999.
- [2] A Kumar, OP Malik, GS Hope. Variable structure-system control applied to AGC of an interconnected power system. *IEE Proceedings, Pt. C*. 1985; 132(1): 23-29.
- [3] Ritter, Andreas. "Deterministic Sizing of the Frequency Bias Factor of Secondary Control". Swiss federal institute of technology (ETH) Zurich. 2011
- [4] Shayeghi H, HA Shayanfar and A Jalili. "LFC design of a deregulated power system with TCPS using PSO". *International Journal of Electrical and Electronics Engineering*. 2009; 3(10): 632-640.
- [5] Shabani, Hamed, Behrooz Vahidi, and Majid Ebrahimpour. "A robust PID controller based on imperialist competitive algorithm for load-frequency control of power systems". *ISA transactions*. 2013; 52(1): 88-95.
- [6] Kumal, Sandeep, et al. "AGC and AVR of Interconnected Thermal Power System while considering the effect of GRC's". 2012.
- [7] Gochhayat, Rashmita. "PSO based PI controller for load frequency control of interconnected power systems". PhD Thesis in National Institute Technology, Rourkela. 2014.
- [8] Tammam MA, Moustafa MA, Ela MA, & Seif AEA. Load Frequency Control Using Genetic Algorithm Based PID Controller For Single Area Power System. In *International*. 12(5).
- [9] K Yassin, E Abd-Raboh and MS Al-Domany. "Fast Power Restoration Via Load Shedding Practices in Egyptian power System". *Mansoura Engineering Journal (MEJ)*. 1992; 17(1): 1-20.
- [10] Y Wang, R Zhou and C Wen. "Robust Load-Frequency Controller Design for Power Systems". *IEE Proc. C*. 1993; 140: 11-16.
- [11] C Chan WC and YY Hsu. "Automatic Generation Control of Interconnected Power Systems Using Variable-Structure Controllers". *IEE Proc. Pt. C*. 1981; 128: 269-279.
- [12] Kumari N & Jha AN. Effect of generation rate constraint on load frequency control of multi area interconnected thermal systems. *Journal of Electrical and Electronics Engineering Research*. 2013; 5(3): 44-49.

- [13] Gozde H, MC Taplamacioglu, and I Kocaarslan. "Application of artificial bee colony algorithm in an automatic voltage regulator (AVR) system". *International Journal on Technical and Physical Problems of Engineering*. 2010; 1(3): 88-92.
- [14] Khedr SFM, Ammar ME & Hassan M. *Multi objective genetic algorithm controller's tuning for non-linear automatic voltage regulator*. In IEEE International Conference on Control, Decision and Information Technologies (CoDIT). 2013: 857-863.
- [15] Soundarrajan A, S Sumathi and C Sundar. "Particle swarm optimization based LFC and AVR of autonomous power generating system". *IAENG International Journal of Computer Science*. 2010; 37(1).
- [16] Abu-Seada HF, Mansor WM, Bendary FM, Emery AA, & Hassan MM. Application of Particle Swarm Optimization in Design of PID Controller for AVR System. *International Journal of System Dynamics Applications (IJSDA)*. 2013; 2(3): 1-17.
- [17] Bhatt VK & Bhongade DS. Design of PID Controller In Automatic Voltage Regulator (AVR) System Using PSO Technique. *International Journal of Engineering Research and Applications (IJERA)*. 2013; 3(4): 1480-1485.
- [18] P Devi1 & R Avtar. Improvement of Dynamic Performance of Two-Area Thermal System using Proportional Integral & Fuzzy Logic Controller by considering AC Tie line Parallel with HVDC link. *IJITKM Special Issue ICFTEM*. 2014; 170-176.
- [19] Javidan J & Ghasemi A. A novel fuzzy RPID controller for multiarea AGC with IABC optimization. *Journal of Engineering*. 2013.
- [20] Ali ES & Abd-Elazim SM. Bacteria foraging optimization algorithm based load frequency controller for interconnected power system. *International Journal of Electrical Power & Energy Systems*. 2011; 33(3): 633-638.
- [21] Nasr Elsisi." Decentralized control of multi area power systems". Faculty of Engineering (Shoubra). MSc Thesis. 2014.
- [22] C jain & HK Verma & LD Arya. "Determination of controller gains for frequency control based on modified big-bang-big crunch techniques accounting the effect of AVR". *IJEET*. 2012; 3(3): 52-62.
- [23] Gurdeepinder Singh, Rajni Bala. "Automatic Generation and Voltage Control of Interconnected Thermal Power System Including Load Scheduling Strategy". *International Journal of Engineering and Advanced Technology (IJEAT)* ISSN: 2249 – 8958. 2011; 1(2).
- [24] Eiben, Agoston E and James E Smith. Introduction to evolutionary computing. Springer Science & Business Media. 2003.
- [25] Yousuf MS, Al-Duwaish HN & Al-Hamouz ZM. *Pso based nonlinear predictive control of single area load frequency control*. In IFAC Workshop on Control Applications of Optimization. 2009.
- [26] Al Rashidi MR & El-Hawary ME. A survey of particle swarm optimization applications in electric power systems. *IEEE Transactions on Evolutionary Computation*. 2009; 13(4): 913-918.
- [27] Singh SN & Yadagiri J. Application of advanced particle swarm optimization techniques to wind-thermal coordination. ISAP'09. IEEE 15th *International Conference on Intelligent System Applications to Power Systems*. 2009: 1-6.
- [28] Nápoles G, Grau I & Bello R. Constricted Particle Swarm Optimization based algorithm for global optimization. *Polibits journal paper*. 2012; 46: 5-11.
- [29] Ahmed S, Tarek B, Djema, N. "Economic dispatch resolution using adaptive acceleration coefficients based PSO considering generator constraints". *IEEE International Conference on Control, Decision and Information Technologies (CoDIT)*. 2013: 212-217.
- [30] Khalifa F, Moustafa Hassan M, Abul-Haggag O and Mahmoud H. "The Application of Evolutionary Computational Techniques in Medium Term Forecasting". Presented at MEPCON'2015, Mansoura University, Mansoura, Egypt. 2015.