

Development of an On-board Diagnostics System Based on Wireless Network

Guosheng Feng^{*1}, Bo Feng², Sumei Jia¹, Lisha Feng¹

¹School of Mechanical Engineering, Shijiazhuang Tiedao University, Shijiazhuang

²Hebei Construction Investment Group Railway Co., LTD, Shijiazhuang,

17 Beihuan Eastern Road Shijiazhuang, Hebei +8631187939466

*Corresponding author, e-mail: fgs2005@126.com

Abstract

In order to control vehicle exhaust emission effectively, an OBD is developed based on Zigbee technology. Overall solution design of the system is proposed and the vehicle-mounted monitoring database is established. The wireless network communication hardware platform is set up by the MC9S08GT60 microcontroller and the MC13192 wireless module. The project document is produced with the help of BeeKit wireless connectivity toolkit. Under the CodeWarrior IDE development environment, the monitoring station coordinator networking program and the vehicle-mounted terminal device networking program are designed. Experimental results shows that this system complete data exchange between the monitoring station coordinator and the vehicle-mounted terminal device and transfer data into monitoring station computer. The wireless network of OBD is realized.

Keywords: automobile, OBD, wireless network, ZigBee, MC13192r

Copyright © 2014 Institute of Advanced Engineering and Science. All rights reserved.

1. Introduction

With the increase of vehicle population, the automobile exhaust emissions have become one of the main factors causing air pollution. In order to control vehicle exhaust emission pollution according to the law, the major automobile manufacturers have equipped their cars with OBD diagnostic system. The system is used in the mid-90s, which has strict emissions pertinence and its essence is to monitor vehicle emissions [1]. Though OBD-II diagnoses some emission-related fault, it cannot guarantee the driver to accept the warning of fault indicator MIL (Malfunction Indicator Lamp) and timely repair the vehicle failure [2-3]. A new generation of OBD systems-The OBD-III is produced, which is featured with the wireless transmission of fault information.

Through wireless cellular communication, satellite communication or Global Positioning System, OBD III system which takes advantage of the small-vehicle wireless transceiver system, can automatically give the management department some information including Vehicle identification number VIN (Vehicle Identification Number), fault codes and location information. On the vehicle emission level, the administrative departments issued a directive including where to accept the maintenance time limits of solving the emissions problem and so on. On the basis of the relevant laws and regulations these information will issue the punishment of forbidding operation for the cars which cause excessive emissions of pollution because of improper maintenance, and also it can lead to punishment to the offenders. OBD-III not only requires related communications technologies, standards and regulations, it also proposes a higher demand on the accuracy and reliability of the OBD system diagnostic functions, now OBD-III is still in development stage [4-5].

This paper develops the vehicle-mounted diagnostic OBD system based on ZigBee technology, comes up with the overall solution design of the system, establishes a monitoring station database, complete the system's hardware and software design, Preliminary realizes OBD system of wireless network, and provides the reference for domestic car OBD - III system development.

2. System Project Design

In order to design the wireless transceiver system which uses ZigBee technology, monitoring stations on the vital communication line and crossings was set up and every station will be equipped with a ZigBee network coordinator (Full Function Device FFD). The vehicle (Reduced Function Device RFD) is a sensor node with transceiver function. Through the license plate number, these nodes correspond to other information of the vehicle uniquely. When the RFD into the coverage of FFD local area network, FFD collects RFD vehicle diagnostic information and it will be transmitted to database of monitor station computer through the serial port and to monitoring center computer finally for completing the on-board emissions monitoring and management [6-9]. Systems network architecture shown in Figure 1.

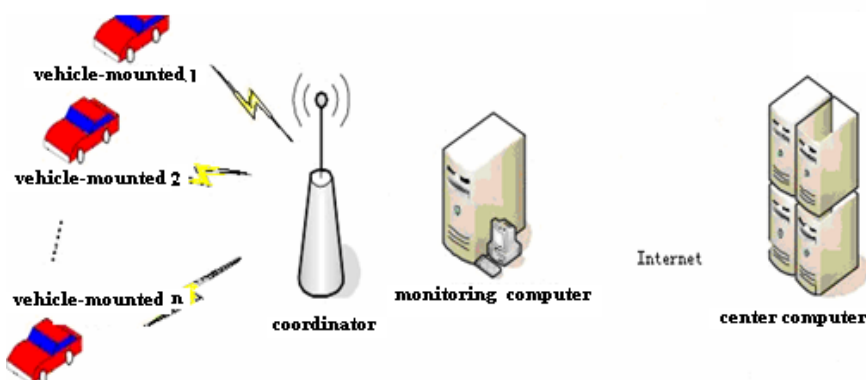

Figure 1. Systems Network Architecture

The system consists of the OBD self-diagnostic system and emissions monitoring system. The prototype of the OBD self-diagnostic system is the OBD-II system which completes the diagnosis of car emission-related parts. The emission monitoring system is the network of OBD system which completes the automatic collecting and processing of diagnostic parameters of the vehicle OBD system under the unsupervised mode [10].

3. Monitoring Station Database

Stations computer can read the vehicles archives information (Vehicle VIN, License plate number, Owners, etc), fault code, etc which are stored in the database [11]. Through the analysis of the fault code, stations computer can give emission level, instruction of maintenance advice and maintenance time limit, etc, and issues fines and banned driving commands to the vehicle which are beyond maintenance time limit. First the monitoring station database was established base on the Access database management system. Then the database was operated using LabVIEW database toolkit. Finally the LabVIEW program for creating forms, adding records and deleting records in the database were designed.

3.1. Establish Database

The function of vehicle-mounted monitoring database mainly includes: Monitoring station information management, vehicle information management, vehicle owner information management, monitoring records management, illegal vehicle management, monitoring information query [12]. To realize its function, the corresponding logical structure was established as shown in Table 1.

For the realization of data revision and query, first the relationship between data table was set up, among them those were correlated that data tables of the vehicle information management, the owner information management, the illegal vehicle management and the monitoring records management with primary key "license plate number" field. At the same time, the data table of illegal vehicle management and the data table of monitoring records management were correlated with "transit time" field. The data table of monitoring station

information management and the data table of monitoring records management were done with "monitoring station numbers".

Table 1. Vehicle Information Management Table Logical Structure

Field name	Field explanation	Data type	Field size	note
VehicleID	license plate number	text	8	Major key
VehicleType	Vehicle type	text	4	—
BuyTime	Purchase time	date/time	—	date
BuyComInsu	purchase compel insurance	logic	2	—
AnnualInsp	annual inspection	logic	2	—

3.2. Database Operation Procedure

In order to realize operation database used the LabVIEW database toolkit, the database will be connected. The method of DSN (Data Source Names) was used for connecting the database to establish the program code as shown in Figure 2. After database is connected, such as create a form, adds records, delete records, inquire the records, close window in database were carried out, the program code of adding records as shown in Figure 3.

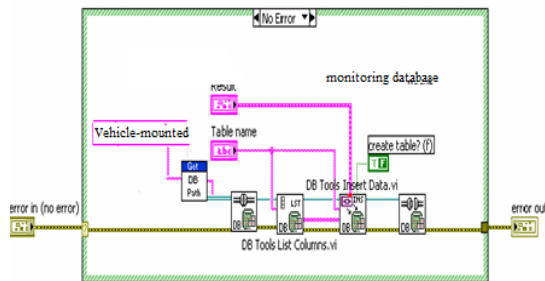

Figure 2. The Program Code of Connecting Database

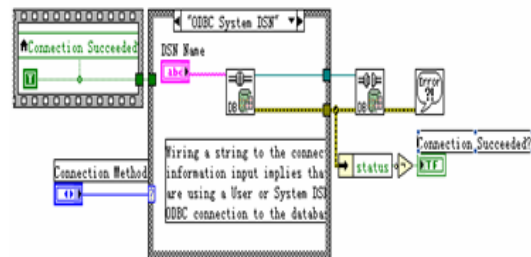

Figure 3 the program code of adding records

4. System Hardware Design

Overall design of the hardware platform between the vehicle terminal and the station coordinator in the wireless network OBD system is shown in Figure 4. Connected with sensors by single-wire, MC9S08GT60 is the core of the entire hardware platform, and is responsible for collecting the signals generated by each sensor and also complete A/D conversion, data processing operations; It communicates with the MC13192 through the SPI bus, completing data transceiver and control information exchange. It is connected with the PC through the RS232 serial port and the BDM interface, completing the display of data and program download, debugging, and other operations, Vehicle terminal completes radio frequency communication with the coordination through two MC13192, uploading data and issuing control directive.

4.1. The Interface Circuit between MC9S08GT60 and MC13192

Since both MC9S08GT60 and MC13192 are from Freescale, and the interfaces are relatively simple: 4 SPI lines, an IRQ interrupt request line and 3 Control lines, as shown in Figure 5.

MC9S08GT60 read and write the MC13192's internal register via 4-wire SPI (MOSI, MISO, SPICLK,SS), During SPI communication, MC13192 serves only as a slave, in terms of MC9S08GT60, MOSI line is sending data line and MISO line is receiving data line. SPI synchronous clock is given in SPSCK pin by MC9S08GT60, and is connected to the MC13192 from the SPICLK pin. SPICLK sign at the rising edge, data begins to transfer, and each transmission requires at least 3 SPICLK pulse group (24 clock pulses); SPICLK at the falling edge, it determines the data transmission flow (enter the host or slave). CE is active at low and powered by MC9S08GT60, and it's role is to allow the SPI to transfer data.

MC9S08GT60 is connected with MC13192 interrupt pin IRQ, and when MC13192 interruption occurs, MC9S08GT60 will capture the interrupt and to determine what kind of interruption it is according to MC13192 interrupt status register, thus providing the corresponding interrupt service.

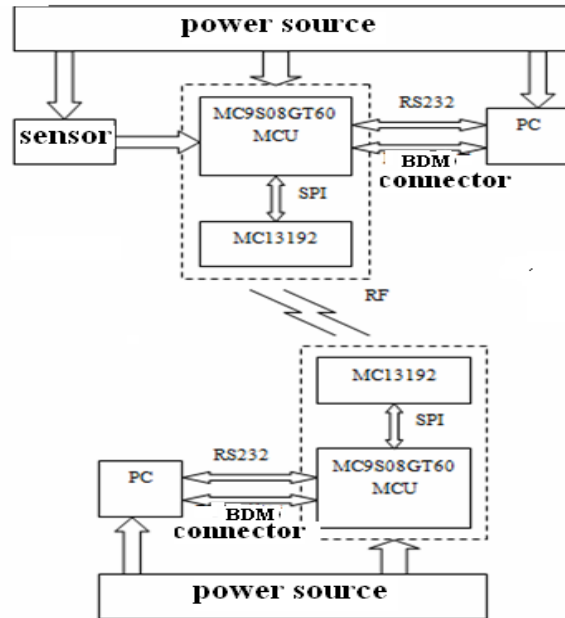

Figure 4. Overall Design of the Hardware Platform

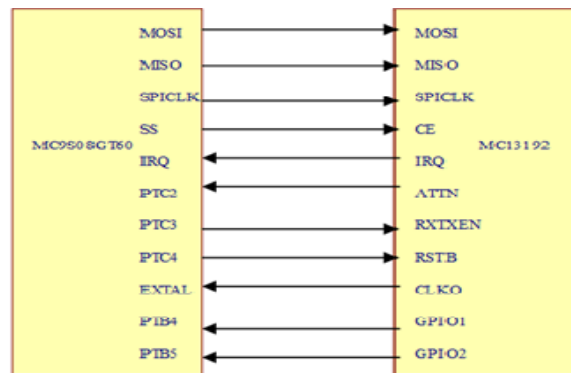

Figure 5. MC9S08GT60 and the MC13192 Interface Circuit

4.2. MC13192 RF Circuit

RF circuit is composed by the signal receiving circuit, the signal transmission circuit and crystal oscillator circuit, shown in Figure 6.

Pin1 and pin2 are signal receiving ends, leading to the signal receiving circuit; pin 5 and pin6 are the signal sender, leading to the signal sending circuit. Chip is connected to an external 16 MHz crystal to form a crystal oscillator circuit, providing the clock signal to the chip.

The role of the antenna is very important in wireless communication systems. The MC13192 works at 2.4GHz and uses balanced monopole antenna or the inverted-F antenna. In this paper, the inverted-F antenna is used and it is embedded directly on the PCB, low cost and good effect.

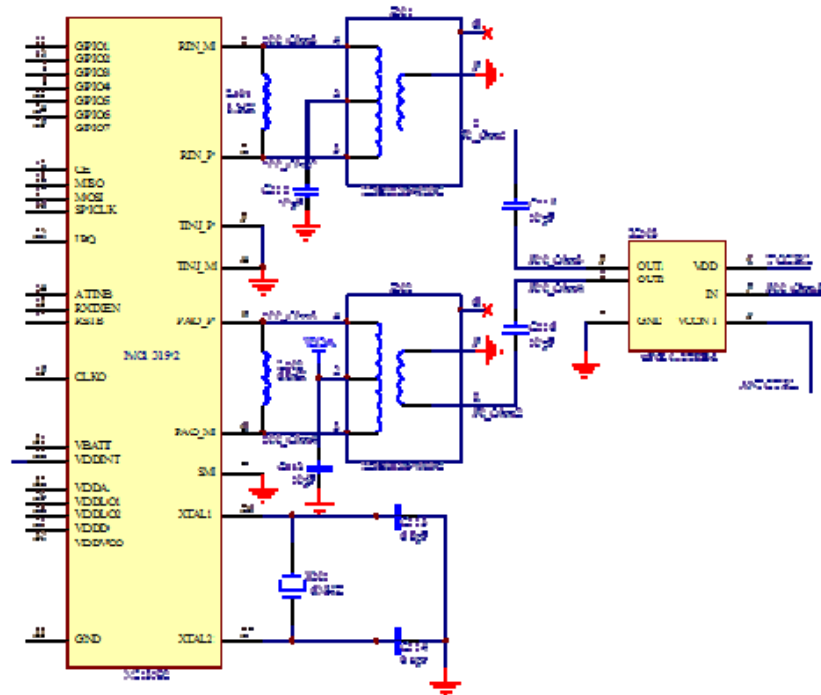

Figure 6. MC13192 RF Circuit

5. System Software Design

Because MC9S08GT60 read and write MC13192 register through the 4-wire SPI interface, it is needed to design the SPI communication [13], and later design the procedure of short distance wireless communication between the coordinator and vehicle-mounted terminal, completing the exchange of data between coordination and vehicle terminal, and transmitting data via the serial port to a monitoring station computer.

5.1. Program Design of the Stations Coordinator

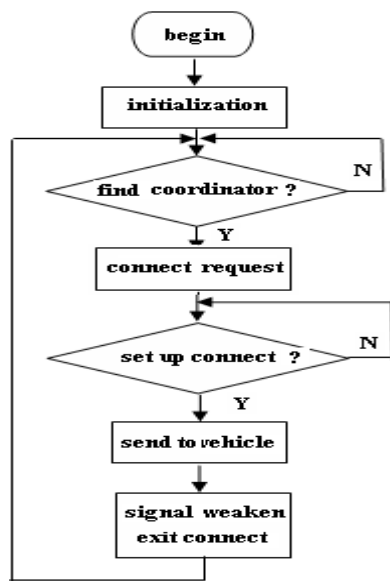

Figure 7. Stations Coordination Network Design Process

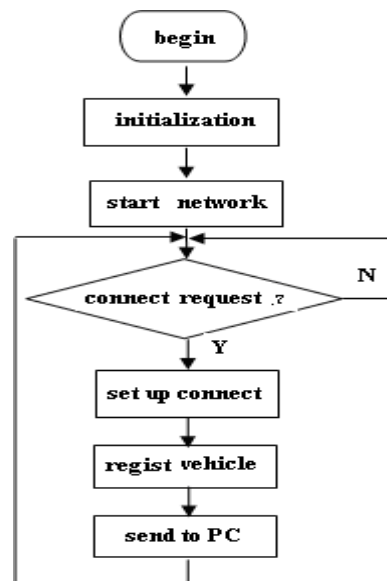

Figure 8. Vehicle Terminal Equipment Network Design Process

The main task of the stations coordinator is to establish a network and receive the information of the vehicle terminal. When coordinator is powered on, it first needs to initialize ZigBee protocol stack, and then network management requires the MAC layer to complete the energy scan of the 16 channel, and to detect whether there are other ZigBee networks in the channels specified by coordinator, and finally select the appropriate channel based on the results of the scan. Then it is needed to select the PAN identifier, ensuring that there is no conflict between the selected PAN identifier and other PAN identifier which is in the same channel. After the PAN identifier is chosen, it is needed to select the network coordinator' 16 short address; at last the coordinator can be started, and begins to receive the connection request of the vehicle terminal equipment, realizing the sending and receiving of the data through CSMA/CA algorithm. Stations coordinator network design' flow chart is shown in Figure 7.

5.2. Program Design of the Vehicle Terminal Equipment

There are two main tasks about the vehicle terminal equipment: firstly, find the network and join the network, secondly, send vehicle's information to the coordinator. When the vehicle terminal go through the monitoring station, vehicle terminal equipment will scan the channel to find stations coordinator, and then issue a request to enter the network, having received the response of the coordinator, it will send their own 64-bit physical address to the coordinator, and after that the coordinator will allocate short address according to the receiving order of the physical address of the terminal equipment. At that time, terminal equipment network is successfully connected. After that, terminal equipment will send the information such as license plate number, vehicle VIN, and whether the emissions are beyond the standard to the coordinator. With the vehicle gradually leaving the stations, the signal of the coordinator gradually decreases, and finally vehicle exits from the network. Vehicle terminal equipment' network design flow chart is shown in Figure 8.

5.3. Program Design of Receiving and Dispatching Oxygen Sensor Voltage Signal

Oxygen sensor is ternary catalytic system components, but also the key sensor that OBD system to test for, and an important change for nantional III emission standard is equipped with the oxygen sensor, so as to better monitor transformation efficiency of the catalytic converter systems. Oxygen sensor output voltage signal collection mainly include four parts: A/D conversion, interrupt handling, SCI serial port to send, LabVIEW serial storage data read [11]. To realize A/D module's collecotion voltage,we can call function getVoltage (), based on the wireless transceiver processes writed in the Zigbee2004 protocol stack as shown in Figure 9.

6. System Experiment

we set a piece of MC9S08GT60 and MC13192SARD plate on the laboratory and a car which is 100 meters away from laboratory, do experiment of coordinator and the vehicle-mounted terminal of dispatch and receipt of monitoring station database information and coordinator receiving oxygen sensor voltage signal.

6.1 Database Information Experiment in Monitoring Station

The 9 voltage power supply was adopted in two pieces of MC13192 SARD. One of them work as the coordinator, the other piece work as vehicle terminal, the RS232 serial line link with the two PC respectively, and the coordinator procedures and vehicle-mounted terminal program were downloaded to the two boards with BDM emulator.

First of all power on the coordinator, and secondly the terminal nodes, and experimental results will be shown in the SSCOM 3.2 serial debugging tools. Serial port sets as follows: Port is the COM 4-port, Baud rate is 57600, data bit is 8, stop bit is 1, no parity and no flow control. Coordinator starts the network and receives the data. Vehicle terminal joins the network and sends the data.The physical address of the coordinator is 0xFFFFFFFFFFFF01, PAN identifier is 0x00001347, the channel is 0x14; The physical address of the vehicle terminal is 0xFFFFFFFFFFFF02, short address is 0x1699, the data to be sent including: plate number

VehicleID is Hebei A, 5C688, StationID is 265 301, passage time is 2011-9-15 14:25:18 and NO emission excessive.

6.2. Oxygen Sensor Voltage Signal Experiment

First of all, the voltage signal of front and back oxygen sensor in the car was connected to vehical-mounted terminal equipment. Then start coordinator and build network. When LED is bright, it shows that the network sets up successfully. After that, the vehicle-mounted terminal equipment was started and let it join the network, when serial port receives related information it shows that terminal equipment join network successfully. Terminal equipment start sending voltage data, coordinator receive voltage data and sent it to the serial port, and Labview application reads serial data, serial port have received oxygen sensor voltage signal as shown in Figure 10.

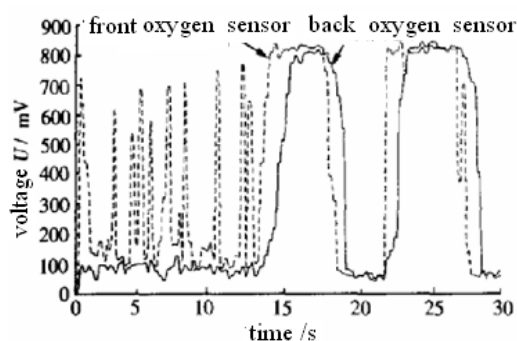

Figure 10. The Voltage Signal of Oxygen Sensor

7. Conclusion

Wireless network board diagnostic OBD system which is based on ZigBee technology development, explores on-board intelligent OBD solution with low-cost and short-range wireless communication interface, and it can be used for online monitoring of the emission control systems and replace some imported products. It completes the preliminary studies for low cost OBD device development with independent intellectual property in China, and the transition from OBD II to the OBD III. It completes the exchange of data between the monitoring station coordination and vehicle terminal, and sends the data to the monitoring station through the serial port, preliminarily realizing the wireless the OBD system.

Acknowledgements

This project was supported by the National Nature Science Fund of China (Grant No.11272220).

References

- [1] FEGN Guosheng, ZHANG Junqing, ZHANG Wei. Light-duty gasoline vehicle OBD parts detection system development. *Automotive engineering*. 2008; 30(7): 602-604.
- [2] YAN Shuanghe, SU Wentao, YANG Weixin. Car remote monitoring system based on OBD II. *World Electronic Components*. 2009; 5: 60-62.
- [3] HUANG Airong, XIANG Zhengtao, ZHANG Tao. Design and implementation of real-time monitoring system of the vehicle information. *Vehicle information real-time monitoring system*. 2010; 31(8): 1839-1847.
- [4] Xiaofan Wu, Chun Chen, Jiajun Bu. An Interference-aware Transmission Power Control Scheme for Vehicular On-board Monitoring Wireless Sensor Network. *TELKOMNIKA Indonesian Journal of Electrical Engineering*. 2012; 10(5): 1077-1080
- [5] Javad Rezazadeh, Marjan Moradi, Abdul Samad Ismail, Fundamental Metrics for Wireless Sensor Networks localization. *International Journal of Electrical and Computer Engineering*. 2012; 2(4): 452~455.

- [6] Tsinoqlou Dimitrios, Samaras Zissis. Malfunctions in selected emissions-related components of euro 4 passenger cars: Emissions increase and OBD system response. *SAE International Journal of Fuels and Lubricants*. 2009; 2(1): 250-258.
- [7] Yufeng Chen, Zhengtao Xiang, Wei Jian, Weirong Jiang. *Design and Implementation of Multi-Source Vehicular Information Monitoring System in Real Time*. Proceedings of the IEEE International Conference on Automation and Logistics. 2009: 1771-1775.
- [8] Huang Yu-Wei, Younq Jieh-Shian, Wu Chih-Hunq, Li Hsing-Junq. *A practice learning of on-board diagnosis (OBD) implementations with embedded systems*. Louisville, KY, United states. Washington: American Society for Engineering Education. 2010.
- [9] Lin Jyonq, Chen Shih-Chang, Shih Yu-Tsen, Chen Shi-huang. *A study on remote on-line diagnostic system for vehicles by integrating the technology of OBD, GPS, and 3G*. Proceedings of World Academy of Science, Engineering and Technology. 200; 56: 435-441.
- [10] BU Jianguo, Zhang Weifeng, ZI Xinyun. light-duty diesel vehicles DPF system diagnostic strategy based on OBD technology. *Automotive Engineering*. 2011; 33(3): 203-207.
- [11] Wagn Ying. highway toll collection system based on ZigBee technology. Anhui: Anhui industrial University. 2009.
- [12] ZHAO Xiaofeng, BAN Jun, SHEN Dangyun. The development of the Vehicle Management Information System Based on Driving Behavior. *Road traffic and technology*. 2010; (8): 299-302.
- [13] FEGN Lisha. Development of an On-Board Diagnostics System Based on Wireless Network. Shijiazhuang Tiedao University. 2011.