

Optimal Selection of UPFC Parameters and Input Controlling Signal for Damping Power System Oscillations

Moslem Salehi^{*1}, Ali Akbar Motie Birjandi²

¹Engineering Faculty, Lorestan University, Khorramabad, Iran

²Department of Electrical Engineering, Shahid Rajaei Teacher Training University, Tehran, Iran

*Corresponding author, e-mail: salehi.mo@fe.lu.ac.ir

Abstract

Unified power flow controller (UPFC), as one of the most important FACTS devices, can be used to increase the damping of power system oscillation. The effect rate of this controller on increasing oscillation damping depends on the appropriate selection of input controlling signal, optimal selection of UPFC controlling parameters, and its proper position in power system. In this paper, the capability of different UPFC inputs is studied by utilizing singular value decomposition (SVD) method and the best UPFC input controlling signal is selected. Supplementary control parameters are also optimally selected by PSO algorithm. This method's accuracy is simulated on a single-machine system connected to infinite bus.

Keywords: PSO algorithm, unified power flow controller (UPFC), low frequency oscillations, FACTS devices

Copyright © 2016 Institute of Advanced Engineering and Science. All rights reserved.

1. Introduction

Power system oscillations are the important subject that should be considered in power systems. The frequency of these oscillations is between 0.2 and 3 Hz; if they are not damping, their range will gradually increase and may endanger the system's stability [1, 2]. For damping of power system oscillations and increasing the system's oscillation stability, it is both economical and effective to install power system stabilizer (PSS) [3, 4]. Nevertheless, PSSs have some limitations and are not the solution by themselves. Flexible AC transmission system (FACTS) devices can cause a substantial increase in power transfer limits during steady state through the modulation of bus voltage, phase shift between buses, and transmission line reactance. FACTS devices are among the tools that have a very important rule in damping power system oscillations. Unified power flow controller (UPFC), as one of the most important FACTS devices, can control the power system parameters such as terminal voltage, line impedance, and phase angle.

Performance analysis and control synthesis of the UPFC require its steady-state and dynamic models. A 2-source UPFC steady-state model including source impedances is suggested in [5]. Wang developed two models of UPFC [6-8] in 1999, which have been linearized and incorporated into the Phillips-Heffron model. Using input controlling signals and appropriate parameters, it can be also efficient in damping the system oscillations [9]. The authors of [10] employed the real-coded genetic algorithm to optimize the damping controller parameters of the UPFC. In [11], bacterial foraging was used for the UPFC lead-lag type of controller parameter design. The imperialist competitive algorithm (ICA) has been used in a variety of research areas [12-16].

One of the important issues, in study and design of UPFC POD controllers, is an adequate input signal for controller. In this paper, singular value decomposition (SVD) method for selection of most suitable control input signal of UPFC to achieve effective damping of electromechanical mode of oscillation, has been presented. UPFC dynamical model is considered using Heffron-Phillips model to obtain its optimal controlling parameters. For signal controlling selection which has maximum effect on the damping of electromechanical oscillations, singular value decomposition (SVD) method is used. Supplementary optimal controlling parameters are also selected using PSO optimization method.

2. Research Method

Figure 1 shows a single-machine infinite-bus (SMIB) power system equipped with a UPFC. Static excitation system (IEEE-STIA type) and four-story turbine with appropriate governor are considered. System parameters and nominal performance conditions are presented in Appendix. As shown in the figure, UPFC consists of a parallel transformer (ET), a series transformer (BT), two three-phase voltage source inverters based on GTO, and a DC link capacitor. Voltage source inverters generate voltage with controllable phase angle and amplitude. For UPFC, there are four m_{SH} (amplitude modulation index for parallel inverter), δ_{SH} (phase angle of parallel inverter), m_{SE} (amplitude modulation index for series inverter), and δ_{SE} (phase angle of series inverter) controlling signals. i_t is armature current, V_b is voltage of infinite bus, V_{Et} is voltage of parallel transformer, V_{Bt} is voltage of series transformer, and i_{TL} is parallel branch current.

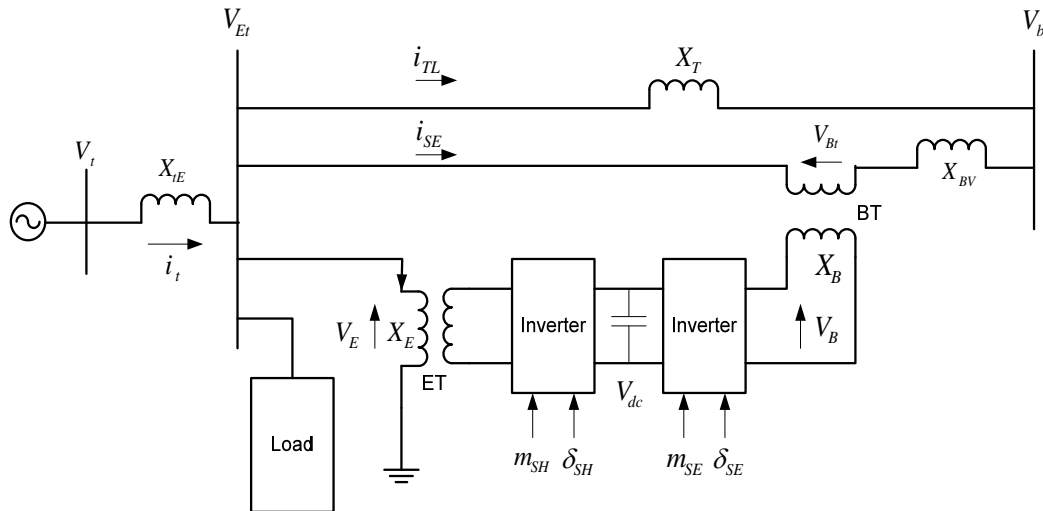

Figure 1. Single-machine infinite-bus (SMIB) power system with UPFC

By writing the dynamic equations for UPFC and system, we can linearize the obtained nonlinear equations using Taylor's expansion around a specific operating point and have the following linear model:

$$\Delta \dot{\delta} = \omega_b \Delta \omega \quad (1)$$

$$\Delta \dot{\omega} = (\Delta P_m - \Delta P_e - D \Delta \omega) / M \quad (2)$$

$$\Delta \dot{E}'_q = (\Delta E_{fd} - (X_d - X'_d) \Delta i_d - \Delta E'_q) / T'_{do} \quad (3)$$

$$\Delta \dot{E}_{fd} = (K_A (\Delta V_{ref} - \Delta V_t + \Delta u_{pss}) - \Delta E_{fd}) / T_A \quad (4)$$

$$\Delta \dot{V}_{dc} = K_7 \Delta \delta + K_8 \Delta E'_q - K_9 \Delta V_{dc} + K_{cSH} \Delta m_{SH} + K_{c\delta SH} \Delta \delta_{SH} + K_{cSE} \Delta m_{SE} + K_{c\delta SE} \Delta \delta_{SE} \quad (5)$$

In these equations, K_{vu} , K_{cu} , K_{qu} , K_{pu} , and $K_1 - K_9$ are linearization constants that can be written in a parametric form. Accordingly, we can show the power system in the state-space model as follows:

$$\dot{X} = AX + BU \quad (6)$$

Matrices A and B are state and input matrices, respectively. State vector X and input vector U are defined as follows:

$$X = [\Delta\delta \ \Delta\omega \ \Delta E'_q \ \Delta E'_{fd} \ \Delta V_{dc}]^t \tag{7}$$

$$U = [\Delta u_{pss} \ \Delta m_{SH} \ \Delta\delta_{SH} \ \Delta m_{SE} \ \Delta\delta_{SE}]^t \tag{8}$$

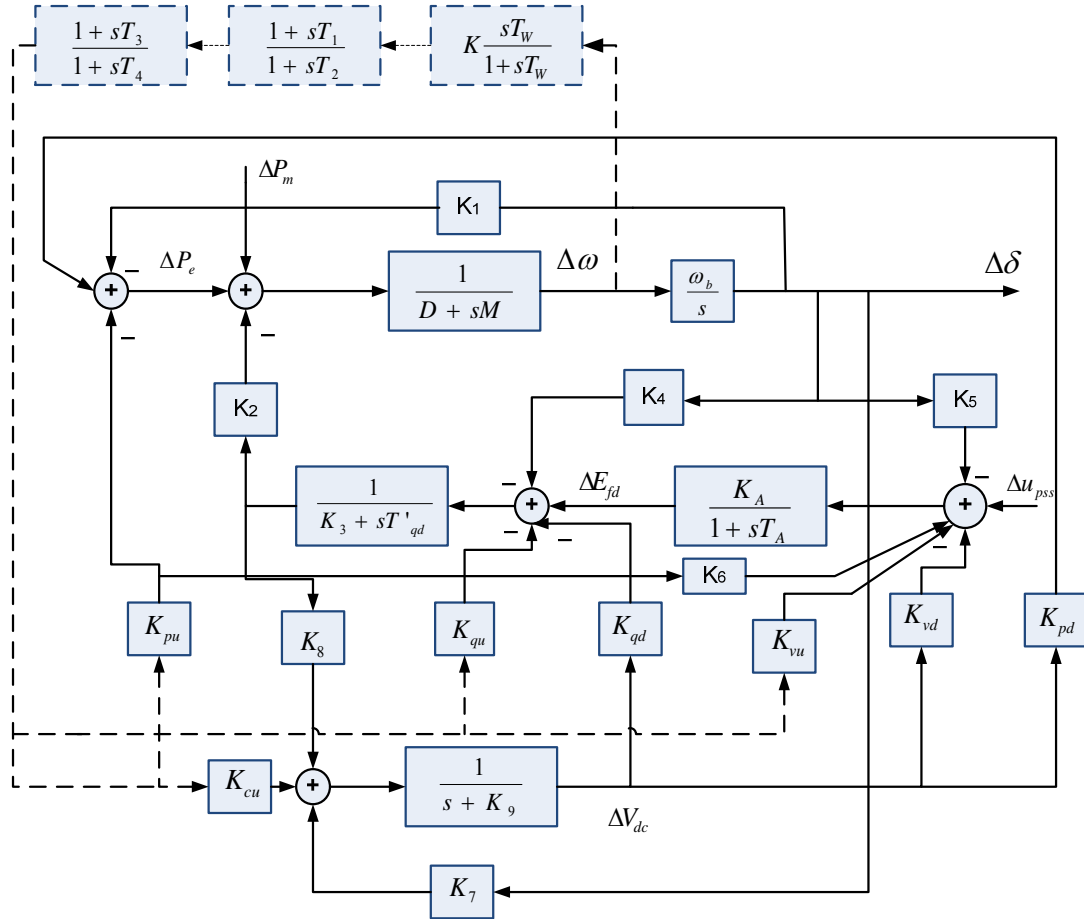

Figure 2. Heffron-Phillips linearized model of power system along with UPFC supplementary controller

Linearized dynamic model of the state–space representation is shown in Figure 2, in which the stabilizer input of power system (U_{pss}) and only one UPFC input control are shown. It should be considered that constants K_{vu} , K_{cu} , K_{qu} , and K_{pu} shown in the figure are row vectors that can be defined as follows:

$$K_{pu} = [K_{pSH} \ K_{p\delta SE} \ K_{pSE} \ K_{p\delta SE}] \tag{9}$$

$$K_{qu} = [K_{qSH} \ K_{q\delta SE} \ K_{qSE} \ K_{q\delta SE}] \tag{10}$$

$$K_{vu} = [K_{vSH} \ K_{v\delta SE} \ K_{vSE} \ K_{v\delta SE}] \tag{11}$$

$$K_{cu} = [K_{cSH} \ K_{c\delta SE} \ K_{cSE} \ K_{c\delta SE}] \tag{12}$$

2.1. UPFC Supplementary Controller

For effective damping increase, supplementary control function helps UPFC via improving its UPFC control function. Supplementary controller's block diagram is shown in Figure 3 [9]. In this block diagram, T_w is wash-out time constant, T_1 and T_2 are lead time

constant, T_3 and T_4 are lag time constant, and K is controller gain. Controlling parameters should be selected so optimally that have maximum effect on damping power system oscillations. In this research, these parameters are optimally selected using PSO algorithm.

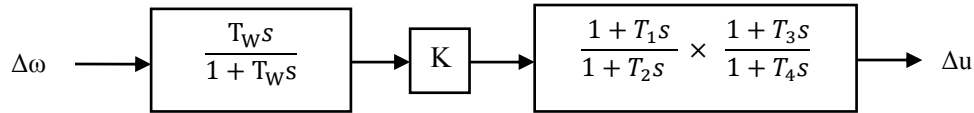

Figure 3. Block diagram of UPFC supplementary controller.

2.2. Optimal Design of UPFC Controlling Parameters

For optimal selection of stabilizing parameters in order to convert the problem into an optimization problem, a criterion function is selected based on specific values, which is then adjusted to increase damping factor or rate related to specific electromechanical values. The objective function can be defined as follows:

$$j = \min\{\xi\} \quad (13)$$

$$\xi = \frac{|Real(EM)|}{\sqrt{Real(EM)^2 + Imag(EM)^2}} \quad (14)$$

Where ξ is damping rate of the mode related to specific electromechanical value (EM). It is clear that the objective function identifies the minimum damping rate of electromechanical modes at all operation points. Thus, we can increase damping rate of electromechanical modes and, accordingly, system damping by maximizing the objective function. So, we will have an optimization problem with the following constraints:

$$K_{si}^{min} \leq K_{si} \leq K_{si}^{max} \quad (15)$$

$$T_{1i}^{min} \leq T_{1i} \leq T_{1i}^{max} \quad (16)$$

$$T_{2i}^{min} \leq T_{2i} \leq T_{2i}^{max} \quad (17)$$

$$T_{3i}^{min} \leq T_{3i} \leq T_{3i}^{max} \quad (18)$$

$$T_{4i}^{min} \leq T_{4i} \leq T_{4i}^{max} \quad (19)$$

Optimal parameters of UPFC supplementary controller are obtained using PSO algorithm. Table (1) shows the numeral values of optimal parameters:

Table 1. Optimal controlling parameters

k	T_1	T_2	T_3	T_4
97.7	0.584	0.298	0.2468	0.4239

3. Investigating Controllability Using Singular Value Decomposition (SVD)

According to Figure 2, it is found that the controlling stabilizer output can be applied to different inputs, i.e. δ_{SH} , m_{SE} , δ_{SE} and m_{SH} of UPFC. For selecting the input with maximum effect in the control of electromechanical modes in different operation conditions, singular value decomposition (SVD) method can be used [17]. In mathematical terms, if G is an $m \times n$ complex matrix, there are W and V matrices with $m \times n$ and $n \times n$ dimensions such that the following relation is established:

$$G=W\Sigma V^H \tag{20}$$

Where $\Sigma = \begin{bmatrix} \Sigma_1 & 0 \\ 0 & 0 \end{bmatrix}$; this is $m \times n$ matrix and Σ_1 is defined as

$$\Sigma_1 = \begin{bmatrix} \sigma_1 & 0 & \cdot & \cdot & 0 \\ 0 & \sigma_2 & \cdot & \cdot & 0 \\ \cdot & \cdot & \cdot & \cdot & \cdot \\ \cdot & \cdot & \cdot & \cdot & \cdot \\ 0 & 0 & 0 & 0 & \sigma_r \end{bmatrix}$$

Where $r = \min \{m,n\}$ and $\sigma_1, \sigma_2, \dots, \sigma_r$ are singular values of G matrix that are located in Σ_1 diagonal matrix in a descending order ($\sigma_1 \geq \sigma_2 \geq \dots \geq \sigma_r$). Matrix B can be written as $B = [B_1 B_2 B_3 B_4]$, where each B_i represents a column of matrix B and is in proportion to the i^{th} input. The minimum singular value of the matrix $[\lambda I - A - B_i]$ indicates the capability of the i^{th} input to control the mode associated with the eigenvalue λ . Thus the minimum singular value of the matrix $[\lambda I - A - B_i]$ corresponding to all four inputs parameters of UPFC, i.e., m_e, m_b, d_e, d_b can be calculated and thus the most effective input parameter out of all four input parameters are identified.

Figure 4 shows the variations of MSV, DCT corresponding to all four control input parameters of UPFC with operating points for a range of loading conditions from 0.3 to 1.6 pu. According to this figure, δ_{SE} and m_{SE} possess the highest SVD. Thus, they have maximum controllability to dampen the electromechanical modes of the power system. According to the figure, the following points are defined:

1. Controllability of δ_{SE} signal is the highest.
2. Controllability of all four controlling signals is increased with load increase.

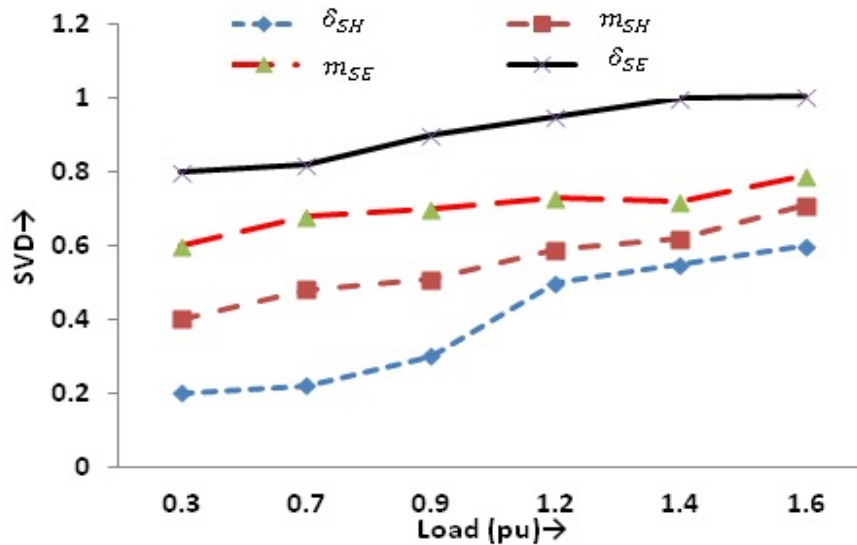

Figure 4. Variation of SVD with load for UPFC control signal

4. Simulation Results

To assess the effectiveness of the proposed stabilizers, the system eigenvalues are obtained and a disturbance increase of 25% in the mechanical input power is considered in order to obtain the dynamic responses. The system eigenvalues with and without the controllers are given in Table 2. It is clear that the system without the controllers is unstable. However, the proposed controllers dramatically stabilize the system. δ_{SE} as the best input controlling signal of UPFC provides maximum damping ratio in the oscillating mode. System behavior due to the utilization of the proposed controllers was tested by applying a 25% step increase in mechanical

input power at $t = 1$ s. The system response to this disturbance for speed deviation, and electrical power deviation with four controllers, as well as without controllers, are shown in Figures 5-8.

Table 2. The system's eigen values with and without UPFC controllers

System without UPFC	δ_{SE}	m_{SE}	m_{SH}	δ_{SH}
	$0.39 \pm 5.17i$	$-6.88 \pm 10.89i$	$-4.12 \pm 9.10i$	$-3.66 \pm 12.72i$
	-0.076	0.54	0.41	0.27
			0.27	0.007

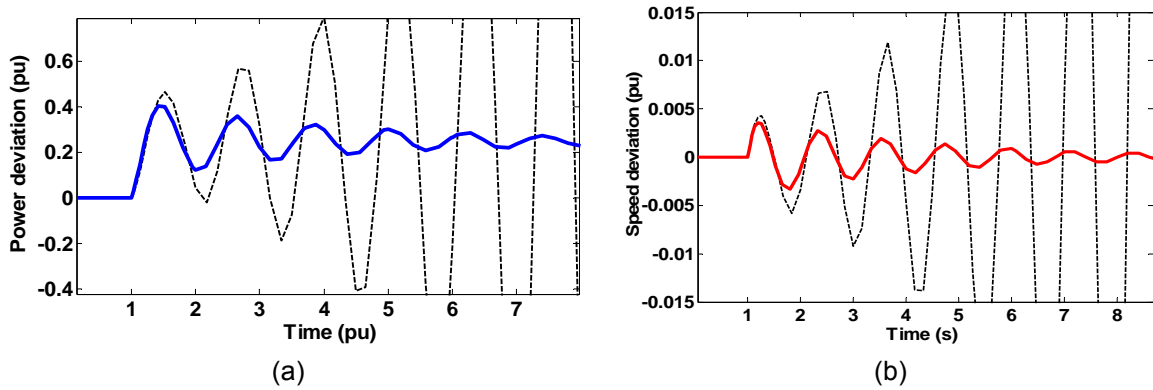

Figure 5. System's dynamic response with controller δ_{SE} : (a) Generator's output active power (pu), (b) Generator's speed variations (pu) . Solid line: δ_{SE} controller, dash line: without controller

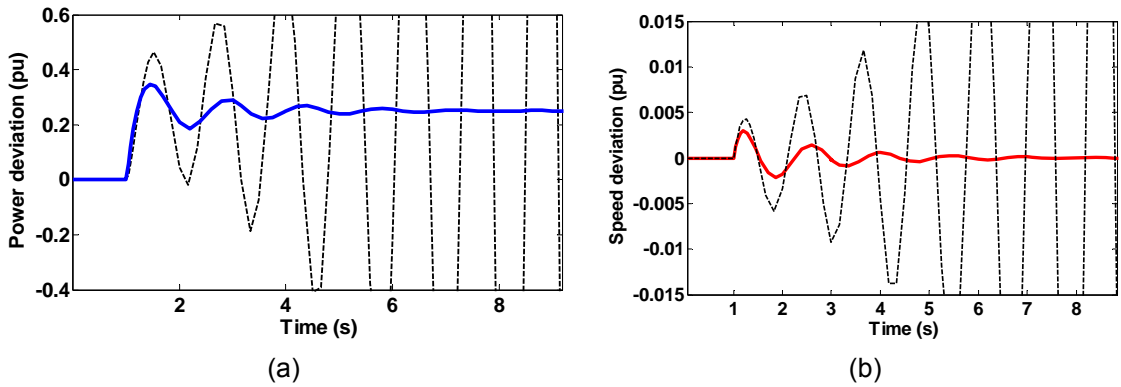

Figure 6. System's dynamic response with controller m_{SH} : (a) Generator's output active power (pu), (b) Generator's speed variations (pu) . Solid line: controller m_{SH} , dash line: without controller

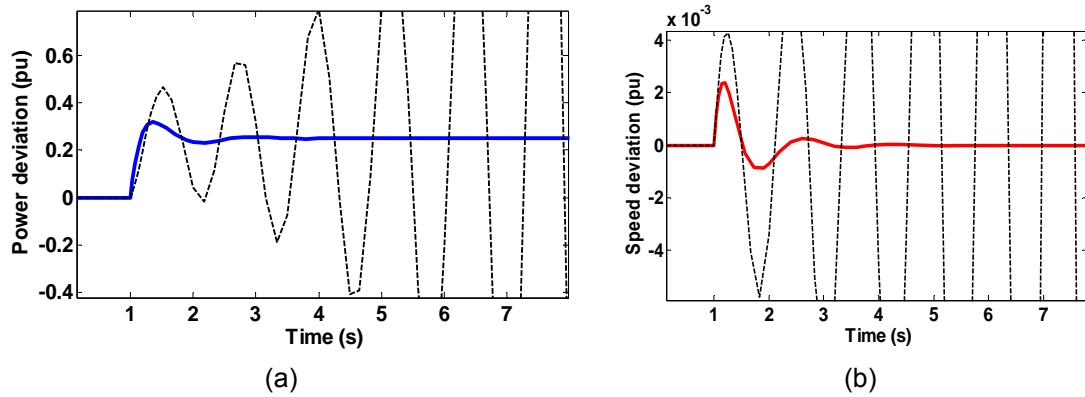

Figure 7. System's dynamic response with controller m_{SE} : (a) Generator's output active power (pu), (b) Generator's speed variations (pu) . Solid line: controller m_{SE} , dash line: without controller

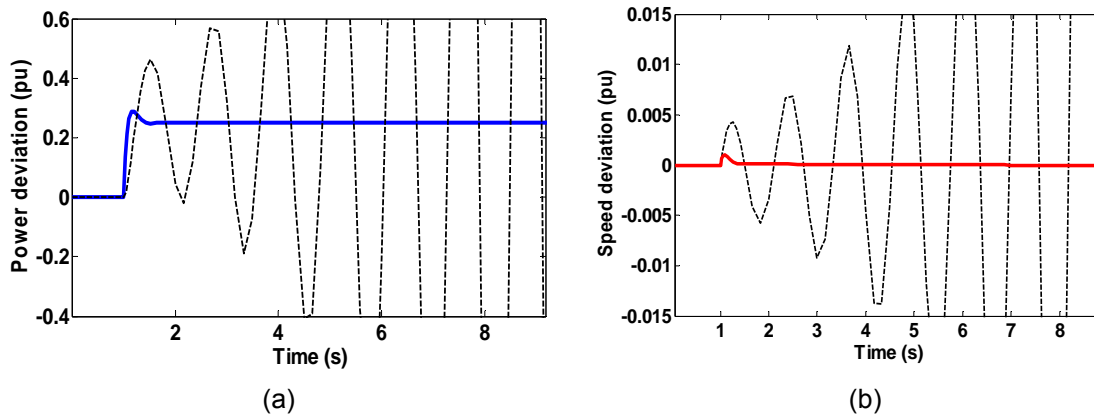

Figure 8. System's dynamic response with controller δ_{SE} : (a) Generator's output active power (pu), (b) Generator's speed variations (pu). Solid line: controller δ_{SE} , dash line: without controller

It can be seen that the proposed objective function-based optimized UPFC controller has good performance in damping low-frequency oscillations and stabilizes the system quickly. Furthermore, from the above conducted test, it can be concluded that the δ_{SE} - based damping controller is superior to the other damping controller, which confirms the results of the singular value decomposition analysis carried out for the UPFC input signals in Figure 4.

5. Conclusion

In this paper, performance improvement of dynamic stability was investigated by UPFC controller. Using PSO optimization method, UPFC damping control parameters were optimally selected. For studying the controllability of four controlling signals in UPFC, single value decomposition (SVD) method was used. According to SVD analysis, it was found that the controlling signal δ_{SE} had maximum controllability for the damping of the power system's electromechanical oscillations. Analysis of eigen values and simulation results of single-machine system connected to infinite bus using MATLAB software properly showed the effect of this proposed method.

References

- [1] Anderson PM, Fouad AA. Power System Control and Stability. Wiley-IEEE Press. 2002.
- [2] Gibbard MJ. Co-ordinated design of multimachine power system stabilisers based on damping torque concepts. *IEE Proc Pt C*. 1988; 135(4): 276-284.
- [3] Lefebvre S. Tuning of Stabilizers in Multimachine Power Systems. *IEEE Trans. Power Apparatus & Systems*. 1983; PAS-102(2): 290-299.
- [4] Awed –Badeeb OM. Damping of Electromechanical Modes Using Power Systems Stabilizers (PSS) Case: Electrical Yemeni Network. *Journal of Electrical Engineering*. 2006; 57(5): 291-295.
- [5] Nabavi – Niaki A, Iravani MR. Steady-state and dynamic models of unified power flow controller (UPFC) for power system studies. *IEEE Transactions on Power Systems*. 1996; 11(4): 1937-1943.
- [6] Wang HF. *Damping Function of Unified Power Flow Controller*. IEE Proceedings - Generation Transmission Distribution. 1999; 146(1): 81-87.
- [7] Wang HF. A unified model for the analysis of FACTS devices in damping power system oscillations part III: unified power flow controller. *IEEE Trans. Power Deliv*. 2000; 15 (3): 978-983.
- [8] Wang HF. *Application of modeling UPFC into multi - machine power systems*. IEE Proceedings – Generation Transmission Distribution. 1999; 146(3): 306-312.
- [9] Tambey N, Kothari ML. *Damping of Power Oscillations With unified power flow controller (UPFC)*. IEE Proceedings - Generation Transmission Distribution. 2003; 150(2): 129-140.
- [10] Baliarsingh AK, Panda S, Mohanty AK, Ardil C. UPFC supplementary controller design using real-coded genetic algorithm for damping low frequency oscillations in power systems. *International Journal of Electrical Power and Energy Systems Engineering*. 2010; 3(): 165-175.
- [11] Tripathy M, Mishra S, Venayagamoorthy GK. Bacteria foraging: a new tool for simultaneous robust design of UPFC controllers. *International Joint Conference on Neural Networks*. 2006: 2274-2280.
- [12] Atashpaz E, Hashemzadeh F, Rajabioun R, Lucas C. Colonial competitive algorithm: a novel approach for PID controller design in MIMO distillation column process. *International Journal of Intelligent Computing and Cybernetics*. 2008; 1(3): 337-355.
- [13] Jahani R. Optimal placement of unified power flow controller in power system using imperialist competitive algorithm. *Middle-East Journal of Scientific Research*. 2011; 8(6): 999-1007.
- [14] Chahkandi Nejad H, Jahani R. A new approach to economic load dispatch of power system using imperialist competitive algorithm. *Australian Journal of Basic and Applied Sciences*. 2011; 5(9): 835-843.
- [15] Bijami E, Askari Marnani J, Hosseinnia S. Power system stabilization using model predictive control based on imperialist competitive algorithm. *International Journal on Technical and Physical Problems of Engineering*. 2011; 3(4): 45-51.
- [16] Etesami MH, Farokhnia N, Fathi SH. *A method based on imperialist competitive algorithm (ICA), aiming to mitigate harmonics in multilevel inverters*. 2nd Power Electronics, Drive Systems and Technologies Conference. 2011: 32-37.
- [17] Pandey RK, Singh NK. *Minimum Singular Value Based Identification of UPFC Control Parameters* TENCON 2006, 2006 IEEE Region 10 Conference. NOV. 2006: 1-4.