

# Determining Basic Cost of Electricity on the Regionalization System

Yusra Sabri<sup>1</sup>, Hermagasantos Zein\*<sup>2</sup>

<sup>1</sup>Electrical Engineering, STEI, Institute Technology of Bandung, ITB Bandung, Indonesia

<sup>2</sup>Energy Conversion Engineering Dept. State Polytechnic of Bandung, POLBAN Bandung, Indonesia

\*Corresponding author, e-mail: yusra.sabri@gmail.com<sup>1</sup>, hermaga\_s@yahoo.co.id<sup>2</sup>

## Abstract

*In electric business, costs that support production called with allowable electric cost or basic cost of electricity. Therefore, the basic cost of electricity has to get more attention seriously from the electric company in order to be trusted by consumers. In determining of the costs must be transparency and do the optimizing in calculating process because of revenues from customers have to be able to cover the basic cost of electricity so that the electric company does not go bankrupt. This paper will create concept and formulations for determining the basic cost of electricity in a region. There are a few different characteristics of each region will influence the costs. The basic cost of electricity can be different among regions that were caused by generating, investment and losses in the region. Later has been done a numerical simulation to simple power system and the results are matching with desired expectations.*

**Keywords:** electric business, allowable cost, create concept, cost formulations

**Copyright © 2016 Institute of Advanced Engineering and Science. All rights reserved.**

## 1. Introduction

Electric business begins from natural monopoly, integrated system, controlled by government. In last three decades, several countries have changed their electric business into forms more efficiency and transparency, i.e. competitive system [1, 2, 3, 4, 5]. Another developing of the integrated system is separated to be a few regions that is called electric regionalization [6], and every regional have independence own authority.

Region authority will be obligated to meet demand with optimal electric cost. So, every region can be distinct its electric cost that suitable with the region condition. In this context, the regions of surplus energy can sell their energy to the regions of minus energy. In the regionalization context, this paper proposes determination basic cost of electricity, or cost. The calculation used in determining the cost will adopts electric and economic formulations. Furthermore, this paper creates a cost concept and formulations for a region. The concept of the cost proposed has been simulated on the simple power system and the results have met the desired expectations.

## 2. Research Method

### 2.1. Terminology and Concept

#### A. Terminology

There are three terms that need to be considered here, namely cost, price and the tariff. The three thing is something different from one and other, and they will be explained the following.

Price is the value determined by the supply and demand. In determining the price is not directly related to production costs. In a market system, when occurs surplus supply then the price will go down, and vice versa. In this case the supplier could get profit or loss. Thus the concept of the price should be in the form of the business market, such as competition.

Tariff states the real price charged to consumers. Usually the tariff is influenced by the ability of (economic and social) of consumers, corporate profits and the government's subsidies, and also influenced by the political will in doing the decision-making. In determining the electric cost is generally defined by compromise (reconciliation) between the parties concerned.

Thereby, the tariff is not only influenced by purely technical but also influenced by the political, economic and social.

While the cost is just a technical nature, i.e. all costs that supports the production of electrical energy from power plants to the region. In this case, the costs are not supporting production process or unallowable cost, such as non-technical energy losses, will not be involved. So, all costs that support the production process is defined as basic cost of electricity in this paper.

### B. The Concept of Cost

As for the costs that will be determined here are for the regions of generation, transmission, distribution, medium voltage and low voltage distribution such as shown by Figure 1. The Figure shows the model of the electric power system that has two types of power plants, namely IPP power plant, independent power production, with the cost of purchase, IPP price, has been determined before, as fixed production costs, and power plants with production costs change every time. The power plants can be connected to the ultra/extra /high voltages or distribution voltage both primary and secondary. Furthermore, the cost can be determined on each consumer, whether the consumers of ultra, extra, high, primary or secondary voltages. In addition, the electric power system can also be divided into several regions, for example Java, Madura and Bali system or JAMALI system, divided into 4 regions, Jakarta-Tangerang, West Java, Central Java and East Java.

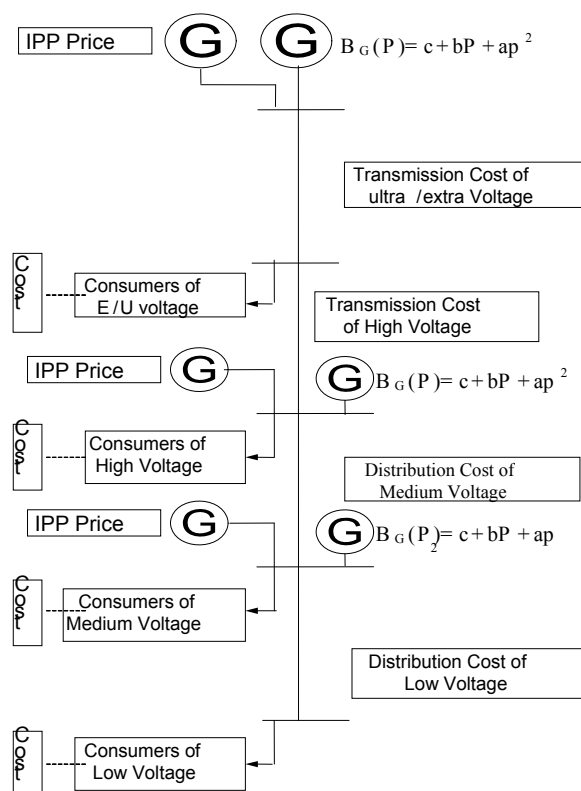

Figure 1. Model complete electric power system

### 2.2 Electric Power System

Referring to Figure 1 above, the electric power system by function can be divided into three sections, namely:

- Generation
- Transmission
- Distribution

### A. Generation

Power plant can be differentiated into two groups, private, IPP, and the state, like PT PLN in Indonesia, companies. Especially for IPP, electricity production costs stated in the purchase price. IPP can be connected to various places in the electric power system, either on the transmission or distribution networks. Cost on the power plant terminal is the production costs before energy transmitted to a grid.

In an electric power system, there are several state power plants connected to the grid in various regions. To determine the amount of power generated by generators at a certain load will be determined based on the optimal power flow so the production cost of power plants to be minimal. Cost determination based on the optimal power flow will use the cost characteristic of power plant in the following equation.

$$B_i(P_i) = c_i + b_i P_i + a_i P_i^2 \quad (1)$$

Where,

$B_i(P_i)$  is basic cost per hour of generating  $i$ .

$c_i$ ,  $b_i$  and  $a_i$  are generating constants

$P_i$  is active power produced by generating  $i$ .

Suppose there are  $N$  buses, total system load is  $P_{sys}$  and total power of IPP is  $P_{IPP}$  then the formulation optimization is

$$\begin{aligned} \text{Objective: } \min B &= \sum_{i=1}^N c_i + b_i P_i + c_i P_i^2 \\ \text{Subject to: } 1. \text{ Generator: } &P_i^{\min} \leq P_i \leq P_i^{\max} \\ 2. \text{ Load: } &\sum_{i=1}^N P_i - P_{Loss} = P_{sis} - P_{IPP} \\ 3. \text{ Line: } &0 \leq S_{ij} \leq S_{ij}^{\max} \\ 4. \text{ Voltage: } &V_i^{\min} \leq V_i \leq V_i^{\max} \end{aligned} \quad (2)$$

Need to remember that the loads will vary each time so the daily load duration curve will be different every day. Experiences show that for working days the curves are almost similar, whereas for red dates and holidays the curve are also quite similar. In the cost calculation will use annual load duration curve of the next year, because the cost will apply for the next year. The annual load duration curve used is the average of the daily load duration curve in one year. Where this curve is estimated from the results of load forecast within the one year ahead. Then, be stated that load every hourly is not change so there are 24 variations of the load in one day. Furthermore, it can be calculated cost each power plant based on estimates of the annual load duration curve through equation 3.

$$B_G(P_i) = \frac{1}{24} \sum_{j=1}^{24} B_i^j(P_i) \quad (3)$$

### B. Transmission

Transmission can be consisted of high, extra and ultra -voltages. The transmission causing cost is due to investment of the transmission network. In the facts, the components of the transmission was built in the times that are not same, there are old components, some components are newly built and some components have been retrofitted. These all must be calculated under annual investment costs based on the economic principle. It should be noted that the outlived components of the economic life will be valued zero in determining the transmission cost. The economic calculation results must be able to determine the annual cost of each component involved in the transmission network. This is very important because in the cost calculation in a region will be determined by the transmission components in the region. But when the components are in the two regions, each region will bear half of cost of the components.

### C. Distribution

Whereas the distribution is distinguished to be two groups, namely the distribution of medium and low voltages. Calculation of the annual cost of this distribution will be identical to the calculation of the annual cost of transmission that have been described above.

### 2.3 Cost Components

As a consequence of the functions of generation, transmission and distribution in an electric power system, the cost will appear on each of these functions. They will emerge in the power plant as costs of the fuel, assets and O&M, or operation and maintenance, whereas in the transmission and distribution networks will emerge costs of asset, O&M and loss energy. Thus there will be five cost components, namely:

- 1) Fuel
- 2) Assets
- 3) Operation & Maintenance (O & M)
- 4) Loss of energy
- 5) Buying and selling of inter-region

#### A. Fuel

Fuel is only found in the power plant only. This component is a mixture of different types of fuel, fuel mix, where power plants involved in electric power systems using various fuels, like water, coal, diesel/MFO and natural gas. Because of the price of each type of fuel and cost-characteristic of each power plant are not same and then it needs to be optimized. Thus here need optimization method to determine the optimal fuel mix in serving total load of system from all power plants connected to the electric power system.

The best optimization method until now is the optimal power flow method. Conceptually, this method is very superior because all constraints have been accommodated in it. But it is less robust in its operation. The robustness will depend on the method used, for example simplex, linear, quadratic, and interior point methods. In the practice of the interior point method, [7], is superior because it is faster and more robust.

The very robust method is economic dispatch, ED. However, this method does not involve constraints of voltage and transmission line so the issue of losses can't be accommodated. As the consequences, it may not be operational because if the ED results are applied will possibly be a few constraints violated, such as the transmission line overloaded. Because of this method is very robust, in practice the losses can be predicted, i.e. 2.5%, and the possibility of the load is not too large, it is advisable to use this method in determining the cost for each component of the robust grid.

#### B. Asset

Asset is the entire investments from power plant to distribution. Providing asset depends also on the reliability level desired. The more assets will be more reliable, but it will cause the higher costs. For example two generating units working on a system would be more reliable when using one unit and so on. Relationship between asset cost provision and reliability is shown by Figure 2. On the Figure, for reliability approaching one requires additional very much asset in order to improve the reliability of a very small.

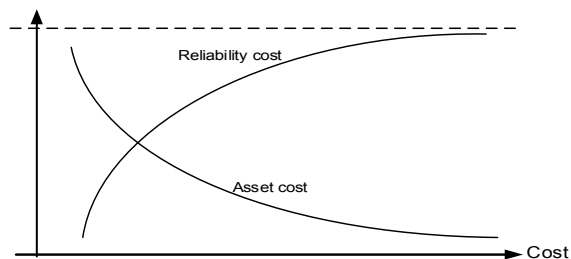

Figure 2. Reliability and asset costs

Generally, procurement of assets are based on the level of reliability to anticipate the component failures, such as n-1, this means that despite of the failure of one component, the system is not collapse. In the rules of the economic, the assets are generally determined by how much depreciation every year. The depreciation is dependent on investments, interest rates, construction and economic life of the asset. The issue of these assets is the design desired to power system based on the quality of service electricity desired. It depends on the ability of the financial government in the responsibility to supply the electricity affordable by the communities. Because of the electric power system is managed by PT. PLN and owned by the government. Obviously this system is a monopoly system by the government.

### C. O&M

In the management of electricity should provide the cost of O&M in order to get good performance. The cost is intended to long operations so there is no problem in the future. It consists of fixed and variable costs. Fixed cost will be related to employees, maintenance, fixed and life cycle, and insurance. While the variable costs consist of startup / start down, oil, fuel additives and chemicals. Determination of the cost is influenced by the real condition of the field in the form of historical data.

But in the reality it is difficult to find this data so it must do the approaches in determining the cost. Besides, it is also influenced by the overall operation plans. The influence of these costs to the overall electric power system is so small with varies between 2-5%, in practice is often taken 4%.

### D. Energy Losses

Energy losses are determined only on the network, both on the transmission and distribution networks. While the power plant is considered supplying to the network with net power. Cost calculation of the energy losses can be derived from Figure 3, which is the transmission line with the current flows to the consumers and grid.

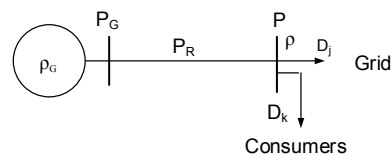

Figure 3. Model of determining the cost of energy losses

From Figure 3, it can be shown that the energy production, in one hour, is equal to the costs received on the bus consumers in the same time. If energy cost is same for all regions, i.e.  $\rho_e = \rho_G$ , the cost of energy losses will be

$$\rho_e P_G = \rho_e (P + P_R) \quad (4)$$

Where,

$\rho_e$  is energy cost

$P_G$  is active power into line

$P_R$  is line losses

$P$  is active power at receipt the consumer bus

So the cost of energy losses in one hour it is

$$B_R = \rho_e P_R \quad (5)$$

Then, from the consumer bus the seen powers flow in two directions, to the consumers,  $D_k$ , and the grid,  $D_j$ , which meet equation  $P = D_k + D_j$ . Furthermore, loss cost will be bear by consumers and determined based on the following approach.

$$B_R^{Dk} = \frac{D_k}{P_r} \rho_e \quad (6)$$

### E. Buying and Selling between Two Regions

In developing the electric business and meet the demands of customers, each region can sell / buy electrical energy from other regions. Surely, for regions as exporter must have surplus energy and vice versa. This illustration can be seen in Figure 4, where region 2 buys energy from region 1. Before transaction, cost in region 1 and region 2 are respectively  $\rho_1$  and  $\rho_2$ . Power is transferred to region 1 is  $P_{tran}$ . While the power produced by region 1 itself is  $P_{G1}$ . So the balance of power in the region 1 is

$$P_{G1} + P_{Trans} = D_1 + P_{L1} \quad (7)$$

Where  $D_1$  and  $P_{L1}$  are demand and losses in region 1, respectively.

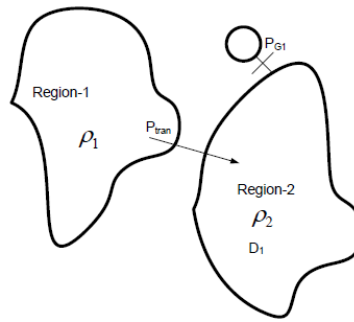

Figure 4. Transactions between two regions

So, cost in the region 1 will change influenced by the cost differences between the two regions, transmission cost and losses cost. So cost after the transaction on region 1 can be calculated as follows.

$$\rho_1^{new} = \frac{\rho_1 P_{G1} + \rho_2 P_{Trans}}{D_1} + \rho_{Trans} + \rho_{Loss} \quad (8)$$

Where  $\rho_{tran}$  and  $\rho_{loss}$  are transmission cost that connects both the regions and the cost of losses caused by the power into region 1.

## 3. Simulation and Analysis

### 3.1 Simulation

Here simulation calculation of electric cost described above will use a simple system in Figure 5. This system is divided into two regions, i.e. region 1 on the top and region 2 on the bottom. There are four transmission lines connecting the two regions and one IPP is in the region 2. Data of system can be seen on the section A consist of data of generation, channel, voltage limits, and others.

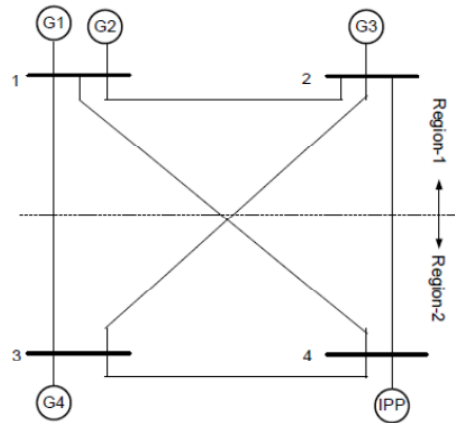

Figure 5. Five bus system

**A. Data**

Table 1. Generating

Generating	c	b	a	$P_{min}$ (pu)	$P_{max}$ (pu)
G1	0	1774,125	0,171	0,3	1,0
G2	0	15	0,0015	0,05	0,25
G3	0	850	0,03	0,02	0,1
G4	0	382,788	0,3808	0,05	0,5
IPP	0	1850	0	0,05	0,2

Table 2. Transmission line

Bus-i	Bus-j	R (pu)	X (pu)	Y (pu)	$S_{max}$ (pu)
1	2	0,15	0,26	0,030	0,75
1	3	0,17	0,30	0,035	0,75
1	4	0,17	0,30	0,035	0,75
2	3	0,14	0,15	0,020	0,75
2	4	0,15	0,18	0,020	0,55
3	4	0,13	0,12	0,015	0,60

Table 3. Bus voltage

No. bus	Region	$V_{min}$ (pu)	$V_{max}$ (pu)
1	R-1	0,9	1,05
2	R-1	0,9	1,05
3	R-2	0,9	1,05
4	R-2	0,9	1,05

Table 4. Load forecast in MW

hour	load	hour	load	hour	load
1	90	9	110	17	160
2	80	10	115	18	145
3	90	11	130	19	143
4	110	12	120	20	145
5	115	13	100	21	145
6	120	14	110	22	130
7	110	15	120	23	100
8	90	16	130	24	90

Notes : Ratio of free days to work days is 0.8  
 Ratio of Saturday to work days is 0.85  
 One year equal to 365

**B. Calculation Results**

Table 5. Optimal fuel mix and energy losses

Item / Region	Fuel cost [RP/kWh]	Energy-losses cost [RP/kWh]
R-1	834.90	22.76
R-2	863.40	17.81

Table 6. Cost of energy losses at distribution

Item / Region	Primary [RP/kWH]	Secondary [RP/kWH]
R-1	35.30	21.51
R-2	24.36	13.66

Table 7. Investment and O&M costs

Item Region	Power plant Inves/O&M	Transmission Inves/O&M	MV Inves/O&M	LV Inves/O&M
R-1	30.87/4.14	10.92/2.09	18.14/2.62	22.07/4.19
R-2	38.21/5.32	14.37/4.04	17.97/4.76	37.93/8.98

Note: in million Rp/day  
 MV: medium voltage  
 LV: low voltage

Table 8. Basic cost of electricity of each region

Region	Power plant	Transmission	MV	LV
R-1	869.91	905.69	961.75	1009.52
R-2	906.93	943.16	990.24	1050.81

Note: in Rp/kWh

Table 9. Energy consumption of each region

Region	Transmission	MV	LV	Sub total
R-1	97.36/20.0	146.05/30.0	243.41/50.0	486.82/100
R-2	71.10/15.0	189.60/40.0	213.30/45.0	474.01/100
TOTAL	168.47/17.5	335.65/34.9	456.72/47.5	960.83/100

Note: in kWh/%

Table 10. Yearly recapitulation of cost and revenue

COST	: [Million Rp]	REVENUE	: [Million Rp]
Fuel	: 813254.1	From HV	: 155241.9
Investment	: 115987.7	From MV	: 328214.0
O&M	: 24086.0	From LV	: 469871.9
Total	: 953327.8	Total	: 953327.8

### 3.2 Analysis

The method developed has been able to perform calculation of the basic cost of electricity, for a region on each of its voltage level. This is shown by simulation for the system bus 5. The simulation results showed that the cost of fuel each region is very dependent on existing power plants in the region itself, and if this region is still lack of power, then owner of the region can purchase energy from other with surplus energy. Accordingly with the formulations above, the energy cost can vary from one region to another and also the cost of losses incurred each region, as shown by the Tables 5 and 6. These differences depend on the characteristics of generation costs in each region, purchasing of power from other regions and the line resistance. Typically, a region has a cheaper energy price is as a surplus region, as shown by those tables, i.e. region 1. While region 2 is as a minus that buys energy from region 1.

If it is involved the cost of investment and O & M in Table 7, it is obtained the basic cost of electricity in Table 8. From this table looks the cost of fuel is very dominant. Generally, the cost of fuel component is around 80% of total cost. This indicates that fuels is absolute to be optimized for reducing the basic cost of electricity. By optimizing fuels then the principles of the least cost in operating the power system will be able to be met.

With the proposed method, the basic cost of electricity can be determined in each voltage level of the consumer, whether it is connected to the networks of high voltage, MV or LV, which is shown by Table 8. This table can be a concern for stakeholders because by knowing the electric cost in the region, then they can take certain steps to reduce the electric cost, such as adding power plants for the minus regions or repairing networks.

In addition, the concept of the proposed method ensures a balance between production costs with revenues, which is shown by Table 10.

### 4. Conclusion

The cost calculation concept proposed has covered all component costs that is only affect production, allowable cost, from power plants to consumers, which includes the costs of fuel, asset, O&M, loss energy in the transmission and buying / selling between regions. The calculation in the simulation states that the fuel cost in the supply of electric power is very dominant, i.e. more than 80%. So, the calculation using optimization to get the minimal cost is the very precise.

The cost should be calculated for one year ahead. This is caused by the price changes for the future is very uncertain, especially for fuel prices. Besides, load forecast can also be inaccurate for a few years ahead. The proposed cost concept has demonstrated its success in the simulation. This is proven by the results of the calculation on the Tables 5-10. Here was



determined the cost that does not only in each region but also individual consumer in each region, i.e. the consumers of the high, medium and low voltages.

### References

- [1] Ilic MD, Galiana F and Fink L. *Power System Restructuring*. Kluwer. USA. 1998.
- [2] Joskow P and Tirole J. Reliability and Competitive Electricity Market. *CSEM WP 129*. University of California Energy Institute. 2004.
- [3] Menteri Pertambangan dan Energi Indonesia. Power Sector Restructuring Policy. The Government's Policy Program for Power Sector Recovery. *Restructuring, Regulatory Reform and Private Participation*. 1989.
- [4] Hermagasantos Z, Yusra S, Ali M. Implementation of Electricity Competition Framework with Economic Dispatch Direct Method. *TELKOMNIKA Indonesia Journal of Electrical Engineering*. 2012; 10(4): 625-632.
- [5] Hermagasantos Z, Yusra S, Erwin D. Determining LBMP through Optimal Power Flow in the Electric Power Business. *TELKOMNIKA Indonesia Journal of Electrical Engineering*. 2014; 12(7): 5086-5095
- [6] Cheng Hsiao, et.al., Modeling Ontario regional electricity system demand using a mixed fixed and random coefficients approach, *Regional Science and Urban Economics*. 1989; Vol. 19, Issue 4, pp. 565-587
- [7] Yan X and Quintana V.H. Improving An Interior Point Based OPF Dynamic Adjustments of Step Sizes and Tolerance. *IEEE Transaction on Power System*. 1999; 14(2).
- [8] Hermagasantos Z and Erwin D. Cost Allocation of Transmission Losses in Electric Market Mechanism. *TELKOMNIKA Indonesia Journal of Electrical Engineering*. 2012; 10(2): 211-218.
- [9] El-Keib AA and X Ma. Calculating Short-Run Marginal Costs of Active and Reactive Power Production. *IEEE Transaction on Power System*. 1997; 12(2).
- [10] Vojdani AF, et.al. Transmission Access Issues, *IEEE Transaction on Power System*, 1996; 11(1).
- [11] Wood AJ and Wollenberg BF. *Power Generation Operation and Control*. John Wiley & Sons, New York, Second Edition. 1996.
- [12] Schweppe FC, et.al. *Spot Pricing of Electricity*. Kluwer. USA. 1998.
- [13] Hermagasantos Z. *Studi Biaya Pelayanan Jaringan Transmisi: Dalam Kontek Kompetitif*. Procceding SSTE-1. 2000
- [14] Hermagasantos Z. *Simulasi kinerja jaringan transmisi dalam kemampuannya menyalurkan daya dari suatu pembangkit*. Prosiding ISSN: 1979-911X, IST AKPRIND. Yogyakarta. 2008.
- [15] Hermagasantos Z. A New Method for Determining Power Decomposition in Electric System. The 12th *International Conference on QiR (Quality in Research)*. Bali. 4-7. 2011
- [16] Wakefield RA. A Transmission Services Costing Framework. *IEEE Transaction on Power System*. 1997; 12(4).
- [17] Hirsh RF. *Power Loss: the origins of deregulation and restructuring in the America electric utility system*. The MIT Press Cambridge. Massachusetts. London. England. 2001.
- [18] Hammons, et.al. European Policy on Electricity Infrastructure, Interconnections, and Electricity Exchanges. *IEEE Transaction on Power System. PES Summer Meeting*. 1997.
- [19] Gedra TW. On Transmission Congestion and Pricing. *IEEE Transaction on Power System*. 1999; 14(1).