

## Design of an orthopedic smart splint using nickel-titanium shape memory alloy

Azza Alhialy<sup>1</sup>, Warqaa H. Alkhaled<sup>1</sup>, Tahani G. Al-Sultan<sup>1</sup>, Zaid H. Al-Sawaff<sup>1</sup>, Fatma Kandimerli<sup>2</sup>

<sup>1</sup>Department of Medical Instrumentation Technology, Technical Engineering College, Northern Technical University, Mosul, Iraq

<sup>2</sup>Department of Biomedical Engineering, Faculty of Engineering and Architecture, Kastamonu University, Kastamonu, Turkey

### Article Info

#### Article history:

Received Sep 11, 2022

Revised Oct 17 2022

Accepted Nov 24, 2022

#### Keywords:

Medical devices

Microcontroller

Nickel-titanium

Shape memory alloy

Smart splint

### ABSTRACT

People with broken bones suffer from symptoms of muscular atrophy as a result of a lack of movement, so it was necessary to find effective solutions due to the relative pain they cause and the difficulty of movement after healing. In this paper, we proposed a smart splint made of nickel-titanium shape memory alloys (SMA) wires. These alloys have unique properties compared to other materials, the most important of which is maintaining the original shape during manufacturing at a certain temperature. Temperature, pressure, as well as humidity, were analyzed and monitored while the patient wore the splint to reach the best possible results by using a microcontroller. The results showed that there was a significant improvement for the muscles in a short time when using the proposed splint, as the percentage of qualified muscle recovery increased by more than 70% when using the usual splint. The wires used had an effective role in rehabilitating these muscles by performing a permanent local massage. due to the different diameters of these wires, a different response to temperature change was recorded.

*This is an open access article under the [CC BY-SA](https://creativecommons.org/licenses/by-sa/4.0/) license.*



### Corresponding Author:

Zaid H. Al-Sawaff

Department of Medical Instrumentation Technology, Technical Engineering College

Northern Technical University

AlMinsaa St., Mosul City, Nineveh Governorate, Iraq

Email: zaidalsawaff@ntu.edu.iq

## 1. INTRODUCTION

New industries based on inventions have witnessed tremendous growth due to the reliance on industrial progress and artificial intelligence. This led to a revolution in the manufacture of materials and outstanding results in terms of the speed of production, low costs, and product quality [1]–[7]. Recently, this new concept of manufacturing has been applied in the medical field, or as it is called, medical device technologies or bioengineering [8]. Because of these unique properties of the new materials, manufacturing technologies have allowed improving the tools and devices used in medicine, especially in the field of orthopedic and maxillofacial surgery, in terms of ease of use and the possibility of using the product more than once in addition to ease of cleaning and the rest of other biological properties [9].

The use of technology in medical devices such as microchips, communication systems, and programming has made it easy to monitor important vital parameters [10] of the patient such as temperature and pressure [11]–[14]. It is now possible to send these parameters to an application that works using a mobile device quickly and quickly and compare the results with the database or send them to the doctor without referring the patient to a competent clinic to see the extent of the development of the case. Smart splints can be included in the field of medical care using the internet of things (IoT) [15], [16], as it has been proven that the use of IoT allows the exchange of data through communication between the network and the devices and

sensors [17], which will reduce the cost of materials and the speed of response of the medical staff, in addition, to complete satisfaction by the patient [18]. Shape memory alloys (SMAs) are defined as a group of materials that can reach a predetermined shape or size once subjected to an appropriate thermal procedure throughout the production process of the designed material [19]. This has been proven by many previous literary studies that studied the properties of shape memory alloys [7], [20]. The idea of designing an intelligent splint with different features has recently attracted many researchers because of its importance in developing methods and reducing the treatment period for patients with various fractures [21]–[25]. In the following paragraph, we will present some of the essential previous literary studies in which researchers designed new systems on this topic.

In March 2020, Al-Sawaff *et al.* [26], designed an electromagnetic field nickel-titanium (Ni-Ti) based smart splint. This splint contains three nickel-titanium wires of different diameters, each of these wires is connected to a constant current source. They proved through practical experiments that the electric current applied to the fracture area was effective in accelerating the healing process of the fractured area. In addition to the other unique specifications of the nickel-titanium wires, they were able to use them to reduce post-fracture symptoms such as atrophy of the surrounding muscles and stiffness of tissues and tendons in the fracture area.

In the same year, Burgo *et al.* [27] designed a smart splint using 3D printing techniques and based on microcontrollers. This smart splint can monitor vital variables such as pressure, temperature, and humidity in the area around the fracture to control them in a short time in case of any emergency. This splint allows readings to be taken from the skin immediately after it is placed or the skin comes into contact with the splint. In the same context, the authors presented another design for a smart splint based on 3D printing, where their design could add any electronic sensor that works by a battery in order to monitor several biological variables in the fracture area such as pressure, temperature, and change in the color of the surrounding tissue. They showed that it is possible in the future to link this cast with an algorithm that predicts future variables and compares them with previously stored data [28].

Also, Li *et al.* [29] presented a model of a smart splint manufactured using 3D printing techniques that can sense the changing pressure in the fracture area in order to detect the area of looseness in the cast and display the results on a screen attached to the splint. This splint can also measure the temperature in all cast areas through a temperature sensor that connects the cast to the patient's skin. In this paper, we designed a smart electronic splint made of a nickel-titanium alloy that can measure and detect vital variables in the fracture region such as temperature, pressure, and humidity. In addition, this splint has the ability to make stimulate the muscles and tissues of the area under the influence (the leg was taken as a case study) using the shape memory property of this alloy.

## 2. MATERIALS AND METHODS

### 2.1. Design of the proposed splint

In order to obtain the best possible specifications when designing the smart splint, the fiberglass material was used to be the basic building block in the manufacture of the smart splint due to the unique specifications that distinguish this material from others [30], the most important of which is the lightweight to compensate for the weight of other electronic components that we need such as the microcontroller and the rest of the other sensors. The splint made of fiber-class material is also considered better than other splints because this material is characterized by high permeability and high ventilation specifications [31]. The nickel-titanium alloy wires are placed on the splint in a square shape shown in Figure 1. Note that we have used three diameters of the alloy wires in order to raise the temperature range affecting the form of the wire when the transformation process occurs [32]. The wiring between the sensor and the circuit board is hidden in grooves.

The transformation is usually known as "martensitic transformation (MT)" while heating the sample from the low-temperature martensitic dimension, the transformation of solid solution into primary solid solution starts at the given temperature austenite starting point ( $A_s$ ) [33]. The transformation is ended at the known temperature austenite finishing point ( $A_f$ ) [34]. At this known temperature, the complete sample is made over again into the first solid solution phase, in the same way [35], while cooling processes from the high-temperature austenite dimension, phase transformation austenite into martensite begins at the fixed temperature martensite start ( $M_s$ ) and finishes at martensite finish ( $M_f$ ) [36]. This is the basis for the work of the nickel-titanium alloy wire, as it returns to its original shape on which it was manufactured when it reached the appropriate temperature. In order to mention, we used three different diameters of wire, as we mentioned previously in Figure 1 and Table 1, to ensure that a simple, distinctive movement remains for the splint surrounding the fracture area and to give an appropriate massage to it, which helps not to numb the area of atrophy in the surrounding muscles. Figure 2 shows the phase transition mechanism of the nickel-titanium shape memory alloy (SMAs).

The fact of the matter is that there are many difficulties in measuring the temperature of the wire due to its small diameter and the condition surrounding the wire. Therefore, the heat transfer analysis [37] of the

wire was carried out using the heat transfer equation for convection with a mass coefficient and Brinson’s model to describe the thermomechanical behavior of the SMAs, as the convection determines the equation of the heat transfer model and the average value of heating and cooling [37]. It is worth noting that the main parameters in this equation are applicable in engineering calculations and can also be easily determined by typical engineering experiments. First, we separate the volume fraction of martensite ( $\xi$ ) into components due to stress ( $\xi_s$ ) and temperature ( $\xi_T$ ) such as (1).

$$\xi = \xi_s + \xi_T \tag{1}$$

Also, the unit of elasticity ( $E$ ) has been assumed as a linear function of the martensitic volume fraction:

$$E(\xi) = E_A + \xi(E_M - E_A) \tag{2}$$

where ME and AE are martensite and austenite phase moduli of elasticity, respectively. The simplified form of Brinson's constitutive equation allows using a more compact form:

$$\sigma = E(\xi)(\epsilon - \epsilon_L \xi_s) + \theta(T - T_0) \tag{3}$$

where  $\sigma$  is the stress,  $\epsilon$  is strain, and  $T$  is the temperature of the wire. Also,  $\theta$  is the thermal coefficient of expansion,  $T_0$  is the initial temperature, and  $L_\epsilon$  is the maximum recoverable strain. The constitutive model tried to find the martensite fraction as a function of stress and temperature [38].

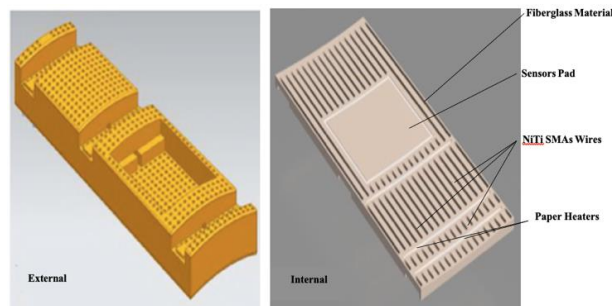

Figure 1. The internal and external shape of the proposed smart splint

Table 1. The mechanical parameters for SMAs wires used

	Diameter (mm)	Tolerances (mm)	UST $\sigma_b$ MPa	Elongation $\delta\%$	Upper Plateau Stress $\sigma_{load}$ MPa	Permanent set after 6% strain %	Active $A_f$ C°
1	2.00~1.00	$\pm 0.015$	$\geq 1300$	$\geq 10$	$\geq 480$	$\geq 0.5$	0 ~ +20
2	1.00~0.35	$\pm 0.010$	$\geq 1150$	$\geq 10$	$\geq 440$	$\geq 0.5$	+10 ~ +24
3	0.26~0.35	$\pm 0.007$	$\geq 1000$	$\geq 10$	$\geq 440$	$\geq 0.5$	+20 ~ +30

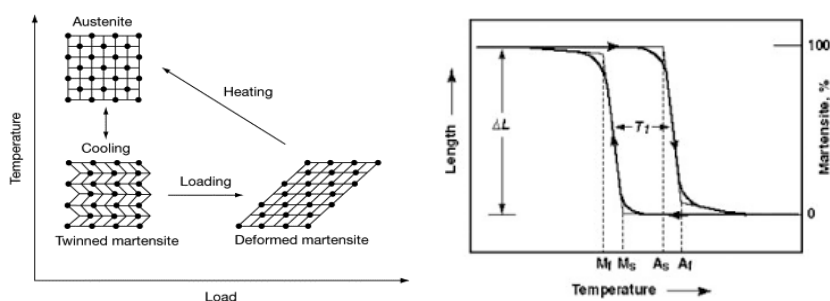

Figure 2. Temperature–transformation curve for a specimen subjected to one cooling–heating cycle, and four characteristic temperatures  $A_s$ ,  $A_f$ ,  $M_s$  and  $M_f$  of the phase transition process

**2.2. Monitoring system**

Our goal in this research was to design an electronic splint that can monitor some vital variables important to the injured area during the healing process. For this, we used a microcontroller [39] of the Arduino nano type because of its unique specifications and qualified at the same time for the proposed splint [31]. We also used pressure AMS 5812 AN02 sensor [40], temperature, and humidity DHT11 sensors [41] to monitor these important parameters during the healing process. The Arduino nano Figure 3 the new ATmega328 microcontroller and Arm's Cortex M0+ power-saving processor, which doubles the flash memory size and gives the processor a higher speed. Also, this type of Arduino is characterized by containing microchip's core independent peripherals (CIP), and its small size characterizes it compared to the rest of the other microcontrollers used in this field, which made it more suitable than others in our research project [41].

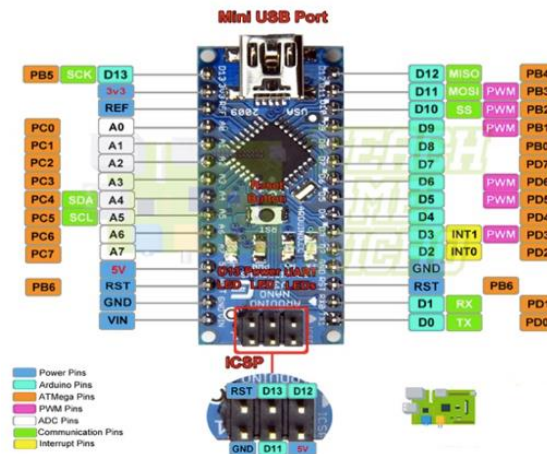

Figure 3. Arduino NANO pin out

The AMS 5812 pressure sensors (Figure 4) are high-precision sensors with two different outputs, the first one is analog, and the second one is I2C digital. The analog supply potentiometer is from 0.5 to 4.5 volts and provides pressure measurement data. On the other hand, the digital output can take measurements of pressure and measurements of temperature. This output was not used in our research, where we used another sensor to measure the temperature.

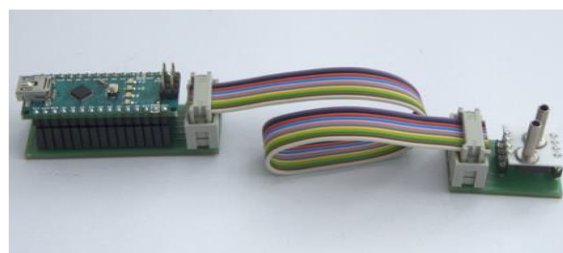

Figure 4. AMS 5812 pressure sensors

The pressure sensors in the AMS 5812 series combine a high-quality piezoresistive silicon sensing element with a modern mixed-signal CMOS ASIC for signal-conditioning on a ceramic substrate. This enables a low total error band, excellent temperature behavior, and high long-term stability, as in Figure 5. Where Figure 5(a) illustrates the functional description for the analog ratio metric voltage output only, it is sufficient to connect PIN2 (GND), PIN7 (VCC), and PIN8 (OUT). To read the digital output only, it is enough to connect PIN2 (GND), PIN7 (VCC), and Figure 5(b) illustrates the electrical connection of the I2C-bus lines to PIN4 (SDA) and PIN5 (SCL).

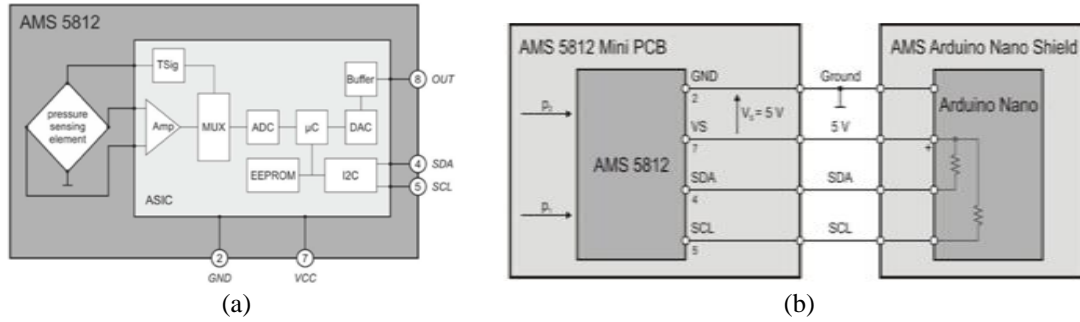

Figure 5. Pressure sensors in the AMS 5812; (a) functional description and (b) electrical connection

DHT11, shown in Figure 6 is a temperature and humidity sensor with four pins-VCC, GND, data pin, and a not connected pin. DHT11 sensor consists of a capacitive humidity sensing element and a thermistor for sensing temperature. The humidity sensing capacitor has two electrodes with a moisture-holding substrate as a dielectric between them. Change in the capacitance value occurs with the change in humidity levels. The process changed the IC measure’s resistance values into the digital form [42]–[44]. This sensor uses a negative temperature coefficient thermistor for measuring temperature, which causes a decrease in its resistance value with an increase in temperature.

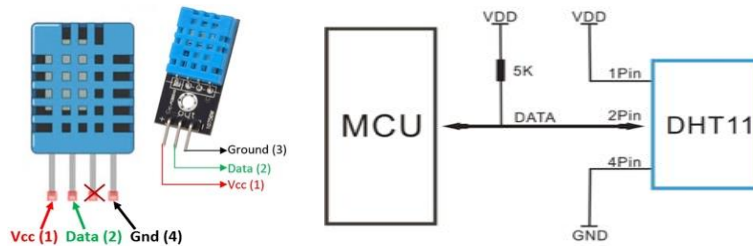

Figure 6. DHT 11 temperature and humidity sensor

### 3. RESULTS AND DISCUSSION

After completing the process of manufacturing the smart splint and connecting the nickel-titanium alloy wires, programming the microcontroller board, and designing the electronic circuits necessary to connect the sensors to the microcontroller begins. Considering that the data obtained from the microcontroller can be received by direct connection between the microcontroller and the PC or by using bluetooth and Wi-Fi previously connected to the microcontroller. It is crucial to monitor data coming from temperature, pressure, and humidity sensors in the area of injury during the period of use of the cast. The circuit structure block diagram is shown in Figure 7. A Li-ion battery [45] powers the entire circuit, where the output voltage for other circuits is regulated at 3.7 V in the power supply circuit.

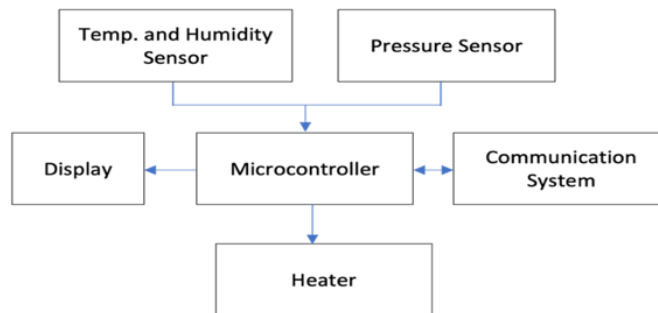

Figure 7. The proposed splint’s microcontroller block diagram

Figure 8 shows the relationship between the temperature taken from the temperature sensors attached inside and outside the splint during a specific period. The results showed that the temperature inside the splint was varied, where values were recorded between 33-36.3 °C. This discrepancy is because the sensor inside the splint was not in direct contact with the skin, as there was an air gap of 4 mm. On the other hand, the second sensor placed on the surface of the splint recorded values 3 °C lower than the first sensor. After taking the average temperatures between the first and second sensors, the change in the temperature of the splint can be measured, which is very necessary for the operation of the paper heaters connected to the cast in order to maintain a constant temperature throughout the treatment period.

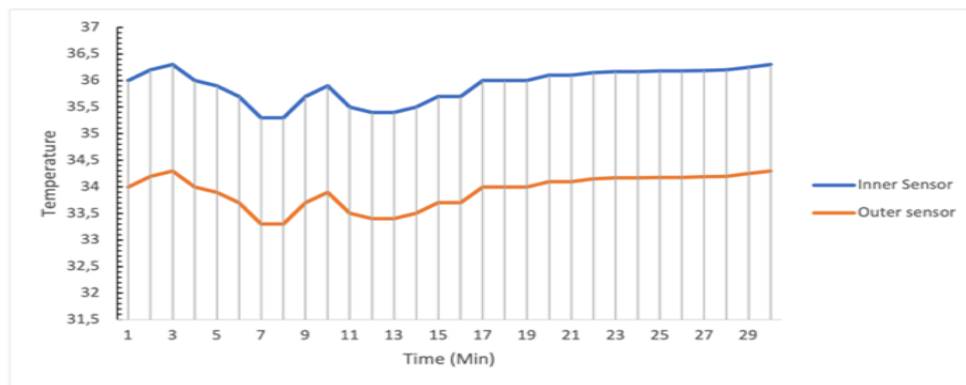

Figure 8. Temperature graph for the inner and the outer sensors

It should be noted that the temperature sensors were connected to three different locations (shown in Figure 1), each location representing one of the used nickel-titanium alloy wires, but with a different radius. The results showed that there is a very slight difference between the percentage of temperature variable recorded at each wire when compared with each other which proves that the heat transfer process is not affected by the dimensions of the wire used. Knowing the amount of moisture inside the splint is very important, especially in cases that have undergone surgery or an injury in addition to a fracture, as humidity plays a significant role in the spread of pathogenic bacteria that cause many types of skin infections at the injury site [46]. Figure 9 shows the humidity value inside and outside the cast taken from the humidity sensor [47] connected inside and outside the splint, the results showed a slight difference in the indoor humidity values over time, and these values are known to be changed according to the physiological nature of the human being in terms of sweating and other environmental conditions. In our research, it was also necessary to know the moisture value inside the cast in order to operate the attached paper heaters to stabilize the moisture value throughout the treatment period.

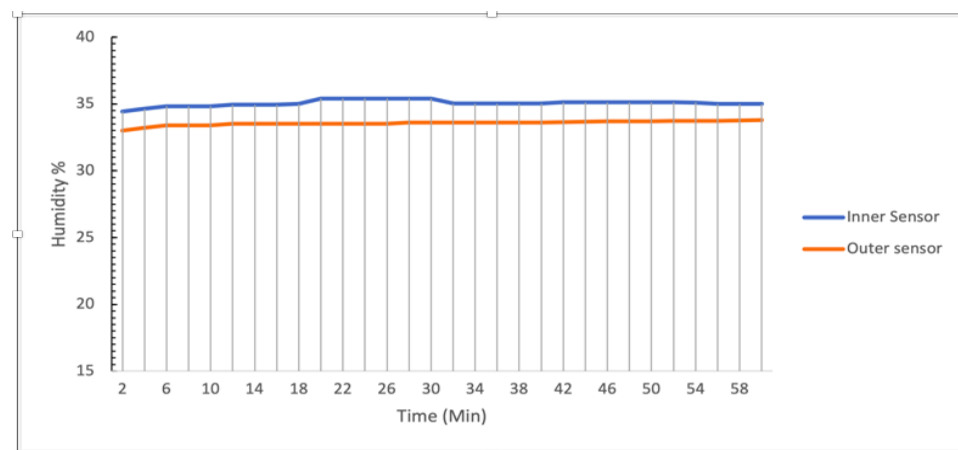

Figure 9. Humidity graph for the inner and the outer sensors

The purpose of attaching paper heaters in our project was to control the temperature inside the cast in the first place, as the change in temperature inside the cast is necessary to stimulate the nickel-titanium wires to carry out the thermal transformation process and thus expand and contract automatically, which helps to put some pressure on the muscles and tissues surrounding the fracture area and thus continuous massage of the affected area. Also, we used an AMS 5812 pressure sensor with a surface area of  $1 \text{ cm}^2$ . Figure 10 shows the average pressure inside the cast, where the graph shows that the value of the pressure applied to the fracture area by the cast is  $58 \text{ gf/cm}^2$ , which is the pressure needed to stabilize the bone and joint that suffers from the fracture in its usual position without moving. In order to know the effect of pressure inside the cast on the affected area, we simulated the presence of swelling in one of the affected areas and under the splint excitation. During the period between the 10<sup>th</sup> and the 16<sup>th</sup> minutes, we noticed that during the increase in the pressure inside the cast by applying an external force, the pressure exerted inside the cast changed to a value of  $95 \text{ gf/cm}^2$ . By referring to the actual situation, the specialist can know the presence and location of swelling inside the injury area by taking advantage of the change in the internal pressure values inside the designed cast.

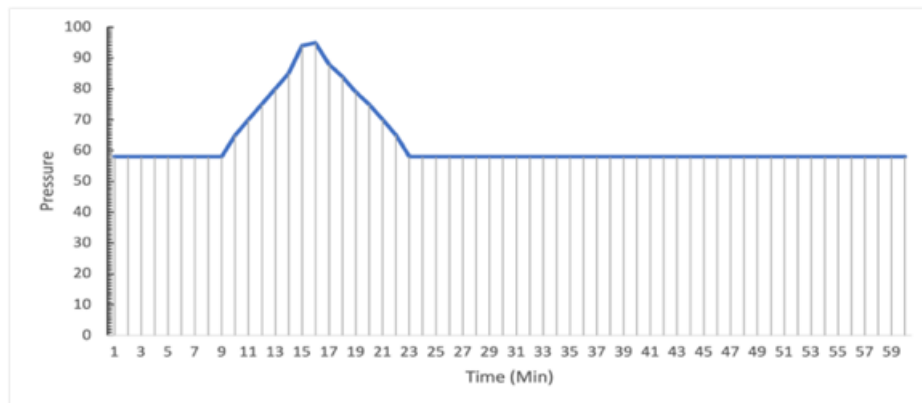

Figure 10. Pressure graph for the AMS 5812 pressure sensor

#### 4. CONCLUSION

For more than half a century, research has been ongoing on humans and animals in order to reveal the relationship between the change in temperature patterns and medical conditions, as the change in the temperature of any area of the body is usually caused by cell metabolism or local blood flow. On the other hand, with some disease processes or during the stages of new bone formation or repair of fractures, a noticeable decrease in the surface temperature of the affected area may occur. The previous projects focused on the manufacturing of various splints for better bone fixation and monitoring the biological changes accompanying the healing process. The fundamental difference between our proposed splint and other projects is that this splint can detect and monitor all the different vital changes and greater fixation of the fracture in addition to maintaining the permanence of the internal movement of the muscles and surrounding tissues through the use of the SMA wires, which led to a shortening of the process of rehabilitation for the injured area after recovery in a record time, which makes it suitable for optimal use by athletes and people who need quick rehabilitation to practice their daily activities. In the case of using a traditional medical splint for any part or broken bone, the weight of this splint may lead to severe problems, in addition to the difficulty of washing and bathing, which may lead to pathological or physical problems of the skin in the area surrounding the broken bone. It is one of the most important daily problems that orthopedic patients suffer from.

This study presents a design for an intelligent splint that can detect and sense the change in temperature, humidity and pressure applied to the affected area for a certain period determined by the doctor in order to discover potential problems in the area of injury during the treatment period, where the data taken from the sensors can be collected. These data can be stored and then compared with the database to monitor the development of the situation. In addition, nickel-titanium alloy wires, which are the backbone of the proposed splint, were used to activate and stimulate the tissues and muscles surrounding the broken bone. We used three types of these wires with different diameters. The reason for this is that these wires gave results different from each other depending on the radius of the cross-section of the wire through the ability of the memory of this alloy to restore its original shape after the removal of external influence, in addition to a group of paper heaters that are used to balance the temperature or humidity inside the cast according to the patient's



need, which will cause local stimulation and massage of the injury area throughout the treatment period and at different temperatures. Furthermore, this proposed splint can be developed, and several other sensors added, as needed, to draw a thermograph or the like for the area under the splint and more accurate monitoring.

## REFERENCES





- [1] U. Jammalamadaka and K. Tappa, "Recent advances in biomaterials for 3D printing and tissue engineering," *Journal of Functional Biomaterials*, vol. 9, no. 1, p. 22, Mar. 2018, doi: 10.3390/jfb9010022.
- [2] K. Tappa and U. Jammalamadaka, "Novel biomaterials used in medical 3D printing techniques," *Journal of Functional Biomaterials*, vol. 9, no. 1, p. 17, Feb. 2018, doi: 10.3390/jfb9010017.
- [3] A. Bandyopadhyay, S. Bose, and S. Das, "3D printing of biomaterials," *MRS Bulletin*, vol. 40, no. 2, pp. 108–115, Feb. 2015, doi: 10.1557/mrs.2015.3.
- [4] H. N. Chia and B. M. Wu, "Recent advances in 3D printing of biomaterials," *Journal of Biological Engineering*, vol. 9, no. 1, p. 4, Dec. 2015, doi: 10.1186/s13036-015-0001-4.
- [5] M. Guvendiren, J. Molde, R. M. D. Soares, and J. Kohn, "Designing biomaterials for 3D printing," *ACS Biomaterials Science & Engineering*, vol. 2, no. 10, pp. 1679–1693, Oct. 2016, doi: 10.1021/acsbomaterials.6b00121.
- [6] P. Valasek, R. D'Amato, M. Müller, and A. Ruggiero, "Musa textilis Cellulose fibres in biocomposites – an investigation of mechanical properties and microstructure," *BioResources*, vol. 13, no. 2, Mar. 2018, doi: 10.15376/biores.13.2.3177-3194.
- [7] F. Blaya, P. S. Pedro, J. L. Silva, R. D'Amato, E. S. Heras, and J. A. Juanes, "Design of an orthopedic product by using additive manufacturing technology: the arm splint," *Journal of Medical Systems*, vol. 42, no. 3, p. 54, Mar. 2018, doi: 10.1007/s10916-018-0909-6.
- [8] S. Affatato, A. Ruggiero, J. S. De Mattia, and P. Taddei, "Does metal transfer affect the tribological behaviour of femoral heads? Roughness and phase transformation analyses on retrieved zirconia and BioloX® Delta composites," *Composites Part B: Engineering*, vol. 92, pp. 290–298, May 2016, doi: 10.1016/j.compositesb.2016.02.020.
- [9] A. P. Fitzpatrick, "Design of a patient specific, 3D printed arm cast," *KnE Engineering*, vol. 2, no. 2, p. 135, Feb. 2017, doi: 10.18502/keg.v2i2.607.
- [10] N. A. A. Rahman and A. B. Jambek, "Biomedical health monitoring system design and analysis," *Indonesian Journal of Electrical Engineering and Computer Science*, vol. 13, no. 3, p. 1056, Mar. 2019, doi: 10.11591/ijeecs.v13.i3.pp1056-1064.
- [11] M. A. Çetinkaya and A. Demirutku, "Thermography in the assessment of equine lameness," *Turkish Journal of Veterinary and Animal Sciences*, vol. 36, no. 1, pp. 43–48, Jan. 2012, doi: 10.3906/vet-1102-791.
- [12] L. Wang *et al.*, "Bisphosphonates inhibit pain, bone loss, and inflammation in a rat tibia fracture model of complex regional pain syndrome," *Anesthesia & Analgesia*, vol. 123, no. 4, pp. 1033–1045, Oct. 2016, doi: 10.1213/ANE.0000000000001518.
- [13] C. H. Rundle *et al.*, "Microarray analysis of gene expression during the inflammation and endochondral bone formation stages of rat femur fracture repair," *Bone*, vol. 38, no. 4, pp. 521–529, Apr. 2006, doi: 10.1016/j.bone.2005.09.015.
- [14] D. V. Dimitrov, "Medical internet of things and big data in healthcare," *Healthcare Informatics Research*, vol. 22, no. 3, p. 156, 2016, doi: 10.4258/hir.2016.22.3.156.
- [15] Y. YIN, Y. Zeng, X. Chen, and Y. Fan, "The internet of things in healthcare: An overview," *Journal of Industrial Information Integration*, vol. 1, pp. 3–13, Mar. 2016, doi: 10.1016/j.jii.2016.03.004.
- [16] A. Zanella, N. Bui, A. Castellani, L. Vangelista, and M. Zorzi, "Internet of things for smart cities," *IEEE Internet of Things Journal*, vol. 1, no. 1, pp. 22–32, Feb. 2014, doi: 10.1109/JIOT.2014.2306328.
- [17] Yuan Jie Fan, Yue Hong Yin, Li Da Xu, Yan Zeng, and Fan Wu, "IoT-based smart rehabilitation system," *IEEE Transactions on Industrial Informatics*, vol. 10, no. 2, pp. 1568–1577, May 2014, doi: 10.1109/TII.2014.2302583.
- [18] G. Jicmon, G. Coşmeleaţă, and D. Batalu, "Investigation of some electrical properties of NiTi wires presenting the shape memory effects," *UPB Scientific Bulletin, Series B*, vol. 71, no. 7, pp. 131–138, 2009.
- [19] M. C. Lin, D. Hu, M. Marmor, S. T. Herfat, C. S. Bahney, and M. M. Maharbiz, "Smart bone plates can monitor fracture healing," *Scientific Reports*, vol. 9, no. 1, p. 2122, Dec. 2019, doi: 10.1038/s41598-018-37784-0.
- [20] A. A. Da Cruz Gomes, E. N. D. Grassi, P. C. S. da Silva, and C. J. de Araújo, "Mechanical behavior of a NiTi superelastic bone plate obtained by investment casting assisted by additive manufacturing," *Smart Materials and Structures*, vol. 30, no. 2, p. 025009, Feb. 2021, doi: 10.1088/1361-665X/abca83.
- [21] M. Formisano, L. Ippariello, A. Casaburi, P. Guida, and F. Clemente, "An industrial oriented workflow for 3D printed, patient specific orthopedic cast," *SN Applied Sciences*, vol. 3, no. 11, p. 830, Nov. 2021, doi: 10.1007/s42452-021-04816-w.
- [22] B. Katt, C. Imbergamo, D. Seigerman, M. Rivlin, and P. K. Beredjikian, "The use of 3D printed customized casts in children with upper extremity fractures: A report of two cases," *Archives of Bone and Joint Surgery*, vol. 9, no. 1, pp. 126–130, 2021, doi: 10.22038/ABJS.2020.47722.2342.
- [23] I. Mihálcz, "fundamentals characteristics and design method for nickel-titanium shape memory alloy," *Periodica Polytechnica Mechanical Engineering*, vol. 45, no. 1, pp. 75–86, 2001.
- [24] F. M. Braz Fernandes, Ed., *Shape Memory Alloys - Processing, Characterization and Applications*. InTech, 2013.
- [25] G. AIROLDI, T. RANUCCI, and G. RIVA, "Mechanical and electrical properties of a NiTi shape memory alloy," *Le Journal de Physique IV*, vol. 01, no. C4, pp. C4-439-C4-444, Nov. 1991, doi: 10.1051/jp4:1991466.
- [26] Z. H. Al-Sawaff, "Electromagnetic field smart splint for bone fixing and rehabilitation using NiTi shape memory alloy," *NeuroQuantology*, vol. 18, no. 3, pp. 37–44, Mar. 2020, doi: 10.14704/nq.2020.18.3.NQ20148.
- [27] J. M. D. A. Del Burgo, F. B. Haro, R. D'Amato, and J. A. J. Méndez, "Development of a smart splint to monitor different parameters during the treatment process," *Sensors*, vol. 20, no. 15, p. 4207, Jul. 2020, doi: 10.3390/s20154207.
- [28] J. M. de Agustín del Burgo, F. Blaya Haro, R. D'Amato, and J. A. Juanes Méndez, "Smart splint for diagnosis during initial stage of treatment," in *Eighth International Conference on Technological Ecosystems for Enhancing Multiculturality*, Oct. 2020, pp. 458–466, doi: 10.1145/3434780.3436610.
- [29] K. Li *et al.*, "Design of an intelligent medical splint with 3D printing and pressure detection," in *2021 IEEE 2nd International Conference on Big Data, Artificial Intelligence and Internet of Things Engineering (ICBAIE)*, Mar. 2021, pp. 655–658, doi: 10.1109/ICBAIE52039.2021.9389935.
- [30] H. Lin, L. Shi, and D. Wang, "A rapid and intelligent designing technique for patient-specific and 3D-printed orthopedic cast," *3D Printing in Medicine*, vol. 2, no. 1, p. 4, Dec. 2016, doi: 10.1186/s41205-016-0007-7.







- [31] J. R. Baker, S. N. Patel, A. J. Teichman, S. E. S. Bochat, A. E. Fleischer, and J. M. Knight, "Bivalved fiberglass cast compared with plaster splint immobilization for initial management of ankle fracture-dislocations," *Foot & Ankle Specialist*, vol. 5, no. 3, pp. 160–167, Jun. 2012, doi: 10.1177/1938640012443283.
- [32] H. Luo, Y. Liao, E. Abel, Z. Wang, and X. Liu, "Hysteresis behaviour and modeling of SMA actuators," in *Shape Memory Alloys*, Sciyo, 2010.
- [33] R. Casati, M. Vedani, S. A. M. Tofail, C. Dickinson, and A. Tuissi, "On the preparation and characterization of thin NiTi shape memory alloy wires for MEMS," *Frattura ed Integrità Strutturale*, vol. 7, no. 23, pp. 7–12, Dec. 2012, doi: 10.3221/IGF-ESIS.23.01.
- [34] M. F. Mahmood, H. F. Jameel, and M. A. N. Hammed, "Measurement of an electroretinogram signal and display waves on graphical user interface by laboratory virtual instrument engineering workbench," *Indonesian Journal of Electrical Engineering and Computer Science*, vol. 25, no. 2, pp. 980–988, Feb. 2022, doi: 10.11591/ijeecs.v25.i2.pp980-988.
- [35] F. A. Hashim, S. B. H. Farid, and E. M. S. Salih, "Surface treatment of NiTi shape memory alloys used in dentistry," *International Journal of Current Engineering and Technology*, vol. 5, no. 6, pp. 3659–3664, 2015.
- [36] O. Yakubu and E. Wireko, "Internet of things based vital signs monitoring system: a prototype validity test," *Indonesian Journal of Electrical Engineering and Computer Science*, vol. 23, no. 2, pp. 962–972, Aug. 2021, doi: 10.11591/ijeecs.v23.i2.pp962-972.
- [37] Z. H. Al-Sawwaf, Z. M. Rashid, M. F. R. Al-Okby, and F. Kandemirli, "A microcontroller based microfluidic biochip for calcium percentage detection in blood," *Indonesian Journal of Electrical Engineering and Computer Science*, vol. 26, no. 1, p. 135, Apr. 2022, doi: 10.11591/ijeecs.v26.i1.pp135-142.
- [38] H. Talebi, H. Golestanian, M. R. Zakerzadeh, and H. Homaei, "Thermoelectric Heat Transfer Modeling of Shape Memory Alloy Actuators," in *The 22st Annual International Conference on Mechanical Engineering-ISME2014*, 2014, p. 1.
- [39] H. Al-Mimi, A. Al-dahoud, M. FEZARI, and M. S. Daoud, "A study on new arduino NANO board for WSN and IoT applications," *International Journal of Advanced Science and Technology*, vol. 29, no. 4, pp. 10223–10230, 2020, [Online]. Available: <http://sersc.org/journals/index.php/IJAST/article/view/33060>.
- [40] K. K. P. O. O. R. M. M. Gabriel, "Monitoring temperature and humidity using Arduino Nano and module-DHT11 Sensor with real time DS3231 data logger and LCD display," *International Journal of Engineering Research & Technology (IJERT)*, vol. 9, no. December, pp. 416–422, 2020, doi: 10.17577/IJERTV9IS120214.
- [41] J. S. Wilson, Ed., *Sensor Technology Handbook*. Elsevier, 2005.
- [42] M. Praveen Kumar and G. Pradeep, "Automated mobile physiological measurement system," in *2012 Third International Conference on Computing, Communication and Networking Technologies (ICCCNT'12)*, Jul. 2012, pp. 1–4, doi: 10.1109/ICCCNT.2012.6396023.
- [43] T. Mahrous Korany Mohamed, J. Gao, and M. Tunio, "Development and experiment of the intelligent control system for rhizosphere temperature of aeroponic lettuce via the Internet of Things," *International Journal of Agricultural and Biological Engineering*, vol. 15, no. 3, pp. 225–233, 2022, doi: 10.25165/j.ijabe.20221503.6530.
- [44] A. M. Alsabari, M. Hassan, A. CS, and R. Zafira, "Modeling and validation of lithium-ion battery with initial state of charge estimation," *Indonesian Journal of Electrical Engineering and Computer Science*, vol. 21, no. 3, pp. 1317–1331, Mar. 2021, doi: 10.11591/ijeecs.v21.i3.pp1317-1331.
- [45] X. Ju, J.-C. Nebel, and J. P. Siebert, "3D thermography imaging standardization technique for inflammation diagnosis," in *Infrared Components and Their Applications*, Jan. 2005, p. 266, doi: 10.1117/12.577055.
- [46] F. Hafeez, U. U. Sheikh, A. Khidrani, M. A. Bhayo, S. M. A. Altbawi, and T. A. Jumani, "Distant temperature and humidity monitoring: prediction and measurement," *Indonesian Journal of Electrical Engineering and Computer Science*, vol. 24, no. 3, pp. 1405–1413, Dec. 2021, doi: 10.11591/ijeecs.v24.i3.pp1405-1413.
- [47] R. Lawson, "Implications of surface temperatures in the diagnosis of breast cancer.," *Canadian Medical Association journal*, vol. 75, no. 4, pp. 309–11, Aug. 1956, [Online]. Available: <http://www.ncbi.nlm.nih.gov/pubmed/13343098>.

## BIOGRAPHIES OF AUTHORS





**Azza Alhialy**     graduated from the Technical Engineering College of Mosul/Northren Technical University/Iraq in 2005 and obtained a Bachelor's degree in Medical Instrumentation Engineering, and in 2021 she obtained a Master's degree in Medical Electronic Instrumentation Techniques Engineering from the Middle Technical University. A faculty member at the Northern Technical University since 2006, lecturer in department of medical equipment technology engineering, and member of the committees in the department. Her interests are in Biomedical, electronics, deep learning, signal processing, Medical Instruments, Image Processing, and she has several published research papers in those field. She can be contacted via the official e-mail: [azzakays@ntu.edu.iq](mailto:azzakays@ntu.edu.iq).





**Warqaa H. Alkhaled**     graduated from the Technical Engineering College of Mosul/Northren Technical University/Iraq in 2005 and obtained a Bachelor's degree in Medical Instrumentation Engineering, and in 2020 she obtained a Master's degree in Medical Electronic Instrumentation Techniques Engineering from the Middle Technical University. A faculty member at the Northern Technical University since 2006, lecturer in department of medical equipment technology engineering, and member of the committees in the department. Her interests are in Biomedical, electronics, deep learning, signal processing, Medical Instruments, Image Processing, and she has several published research papers in those field. She can be contacted via the official e-mail: [warqaahasim@ntu.edu.iq](mailto:warqaahasim@ntu.edu.iq).





**Tahani G. Al-Sultan**    graduated from the Technical Engineering College of Mosul/Northern Technical University/Iraq in 2000 and obtained a Bachelor's degree in Medical Instrumentation Engineering, and in 2020 she obtained a Master's degree in Medical Electronic Instrumentation Techniques Engineering from the Middle Technical University. A faculty member at the Northern Technical University since 2002, lecturer in department of medical equipment technology engineering, and member of the committees in the department. Her interests are in Biomedical, electronics, deep learning, signal processing, Medical Instruments, Image Processing, and she has several published research papers in those field. She can be contacted via the official e-mail: [tahaniaal-sultan@ntu.edu.iq](mailto:tahaniaal-sultan@ntu.edu.iq).

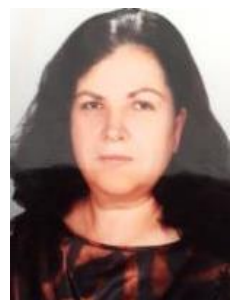

**Zaid H. Al-Sawaff**    received the Technical Bachelor's Degree in medical instrumentation technology from the Northern Technical University, Iraq. The M.Sc. degree in Biomedical Engineering from Osmania University, INDIA 2015. in the present time, he got his Ph.D. in Biomedical Engineering from Kastamonu University, Turkey 2022. He is currently a lecturer with the Department of Medical Instrumentation Technology, Technical College, Northern Technical University, Mosul-IRAQ. he has supervised many B. Scs and M.Sc. students in Kastamonu University have authored or co-authored more than 19 articles. His research interests include Medical Instrumentation, Biomedical Engineering, Computational chemistry, and Nanotechnology. He can be contacted by email: [zaidalsawaff@ntu.edu.iq](mailto:zaidalsawaff@ntu.edu.iq).



**Fatma Kandemirli**    obtained her Ph.D. at Gebze High Technology Institute, Chemistry Department, in 1999. 2005-2010 Associate Professor, Department of Chemistry, University of Kocaeli, Kocaeli, Turkey; 2010-2012 Professor, Department of Chemistry, University of Niğde, Niğde, Turkey; 2012 Professor, Department of Biomedical Engineering, University of Kastamonu, Kastamonu. Dr. Kandemirli's activities and interests are Synthesis of inorganic compounds, QSAR, reaction mechanism, quantum chemical calculations, quantum chemical calculations of corrosion inhibitors. She has published 125 peer-reviewed scientific papers. She can be contacted by email: [fkandemirli@yahoo.com](mailto:fkandemirli@yahoo.com).