

Design of a Subsequent Water Detection System Controlled by the Microcontroller

Chu Yan*, Tang Kang, Feng Xiaoming, Cai Xinyuan, Chen Pengju

The Institute of Electronic and Control Engineering Chang'an University, Xi'an, China

*Corresponding author, e-mail: yanchu@chd.edu.cn, hpblues@vip.qq.com

Abstract

This article instructs the subsequent water detection system design and implementation of sanitary ware. This system used C8051f040 Microcontroller as the main control module and communication module which controlled the operation of the entire system, touch screen as a position machine, and made use of metal probing technique and weighing sensor technology to realize data test, collection, display, storage and export. At last, the experimental results showed that this system meets the expected requirement and can measure the subsequent water more accurately.

Keywords: Automatic control, Subsequent water, Metal probing technique, Touch screen, C8051f040 Microcontroller

Copyright © 2014 Institute of Advanced Engineering and Science. All rights reserved.

1. Introduction

As people's living standard improved, sanitary ware is taken seriously, and the quality of the products is getting more and more people's attention. As an important class of sanitary quality indicators, rinse function response its flushing capacity and effectiveness directly. Therefore, it has become very important to detect the subsequent water accurately in the process of the manufacture and doing research on sanitary ceramics [1]. Here, the subsequent water refers to the water followed after when the simulation objects pass through the outlet of the toilet. It keeps the sewage pipeline achieving self-cleaning by flushing the simulation objects into the standpipe via the socket pipe and the connecting pipe, and using the displacement water to seal water at the same time without the make-up water.

In order to detect whether the sanitary ware is in accordance with industrial standards (refer to EN977-2012) more accurately, more practically and more simply, this paper developed an subsequent water detection system using on sanitary ware, which took the control technology based on C8051F040 microcontroller as the core, and based on an integrated measurement including metal detection technology, sensor technology. It's an effective system on detecting yield of the subsequent water [2].

2. The Basic Idea of System Design

If we put four simulation objects in the toilet, the system should be able to accurately detect whether the objects are washed away or not, and send a signal to the main control system when flushing the toilet. When the objects are washed away totally, the system should be capable of collecting the finalvalue of the subsequent water, and display it on the terminal. In consideration of these requirements, the overall framework of the design in this paper is shown in Figure 1.

The simulation objects detection module is mainly composed of ferromagnetic coils, and it samples the magnetic field changes when the simulation objects (within a metal ring) pass through the coil. The weighing module is mainly formed by a weighing sensor, which can accurately detect the changes of water yield [3]. The master control module taking C8051F040 as the core, is used for signal and data processing. The communication module and the interactive interface, mainly to complete the data processing and display, are made up of C8051F040 and a touch screen. As shown in Figure 2, when the system detects a simulation object, the counter plus 1, and it can be judged as the last simulation washed away when the counter is 4. At this time, the weighing module reads the water level, and determines whether it

is stable. If stability, then it reads the subsequent water value and display the result on the terminal.

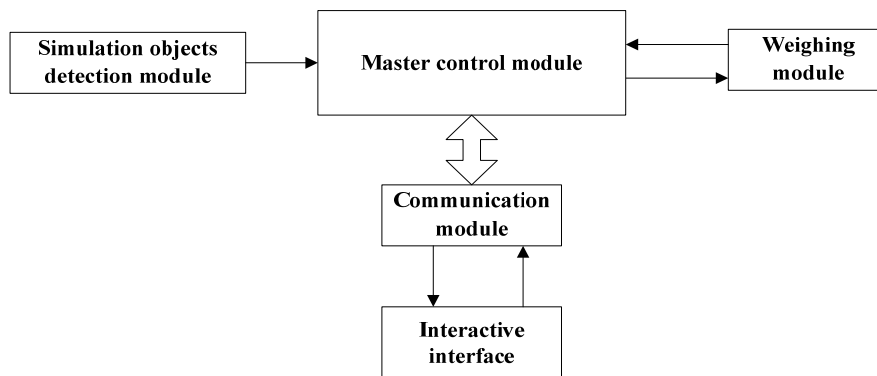

Figure 1. The overall framework of the system

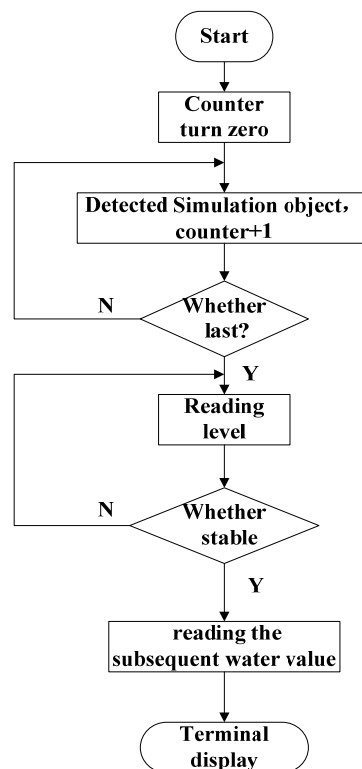

Figure 2. System Detect Process

3. System Modules Design

3.1. The Design of Simulation Objects Detection Module

3.1.1 The Choice of Simulation Objects

Based on the 6 liters of water toilet system evaluation methods in accordance with DIN standard, we select a standard test specimen as the stimulant-Artificial casings (Tubular) with metal Inductive loop, filled with water and covered with bate. Then tie it into three sections with a length of 160mm and a diameter of 25mm. Each test uses 4 test specimens to simulate shit excreted by a person each time. This specimen with a good simulation feature not only can truly

evaluate the flushing smoothness of a toilet supporting systems, but also can be used repeatedly [4].

The size and shape of a standard specimen are shown in Figure 3. The number 1-10 each in turn represents 37 ml water, artificial casings, the tied horizontal plane, linen thread, the horizontal plane without tied, "O"-rings, metal rings (blows), "O"-rings, and the linen thread.

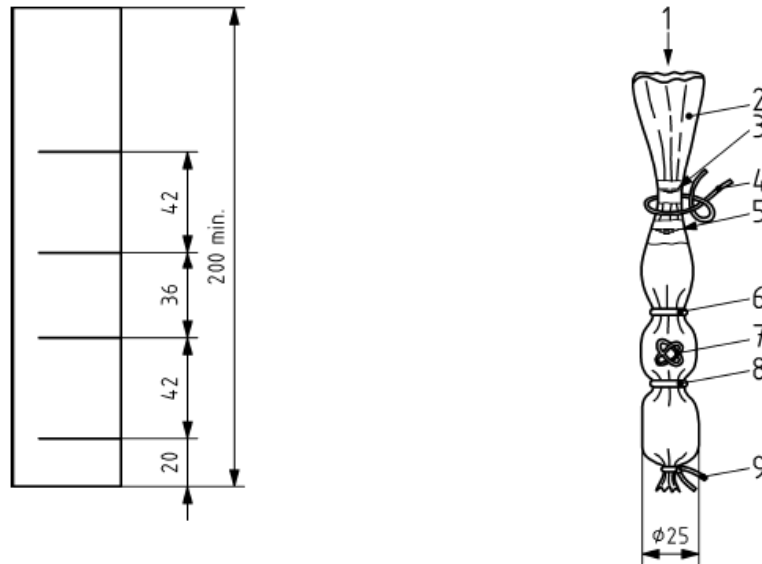

Figure 3. Standard specimen size and shape

3.1.2. Detection Coil Wound

Simulation objects detection module mainly consists of ferromagnetic coils which include an excitation coil and two detection coils. When the mimetic passes through the interior of coil with flush water, the metal ring in the mimetic causes slight magnetic field variations. Then with a signal amplifier, the mimetic detection module can capture the signal reflecting changes in the magnetic field [5]. Geometry of the coil is shown in Figure 4. In this sectional view, the gray part is the wound, and the white part is a hollow cylinder.

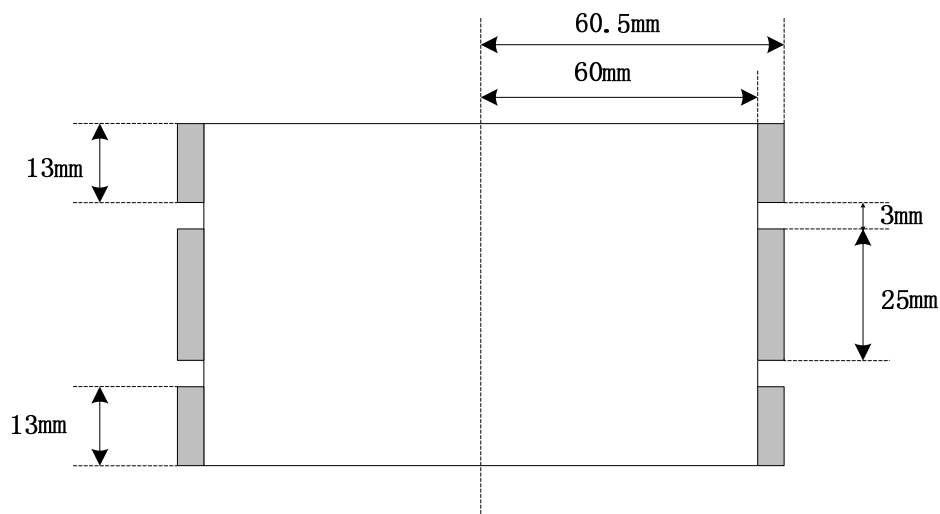

Figure 4. Geometry of the coil

The sensing coil in Figure 4 is made of enameled coppers with a diameter of 0.5 mm. It is Single layer wound on a cylindrical Plexiglas, with 50 turns of excitation coil, and 26 turns each of two detection coils. In these processes, the key is to ensure the uniformity and symmetry relative to the excitation coil of the two detection coils as far as possible[6]. The detecting circuit diagram is shown in Figure 5.

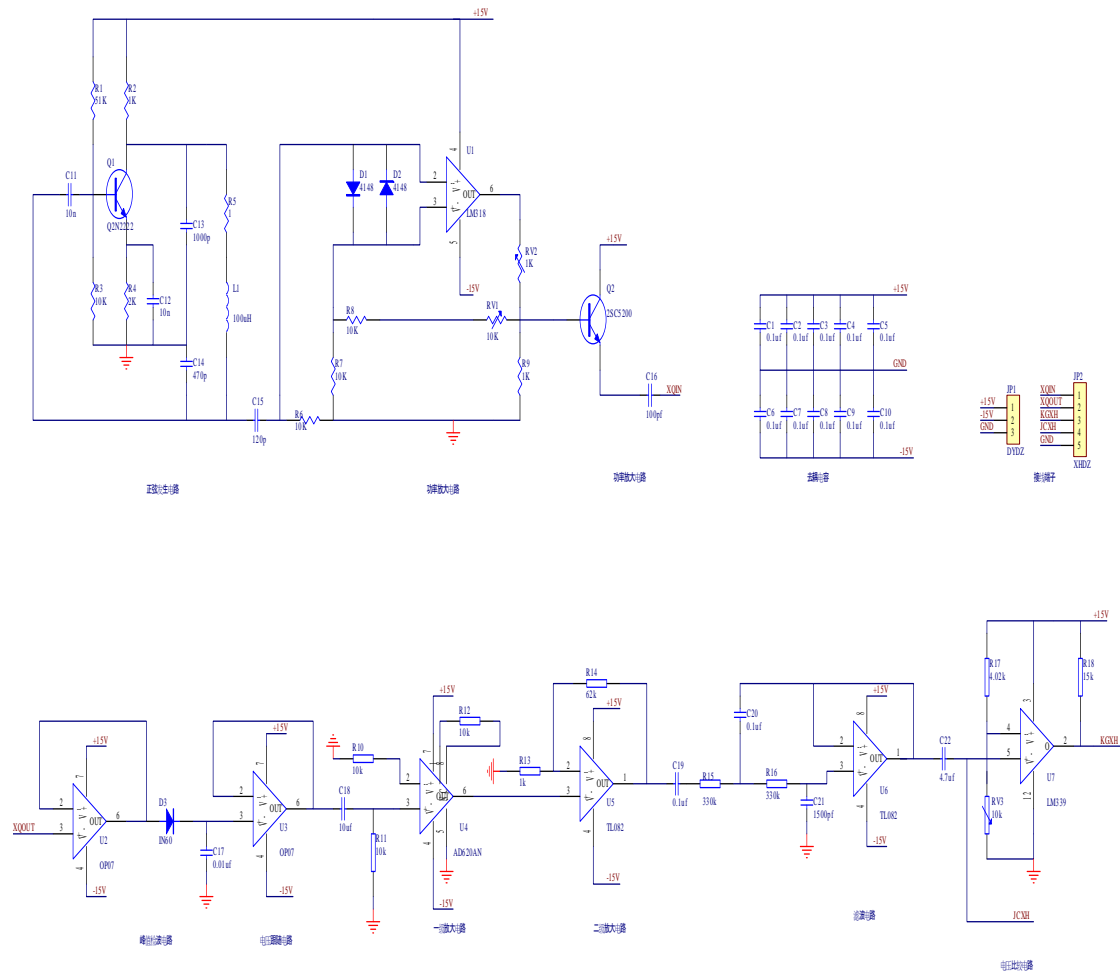

Figure 5. Detecting circuit diagram

3.2. The Design of Weighing Module

The subsequent water is measured by weighing sensor, which converts the pressure signal generated by the subsequent water into a voltage signal. Then by amplification and ADC processing, the value of follow-up water can be read out. To meet the design performance requirements, accuracy of the sensor plays a decisive role, so this design selects the high-precision strain gauge sensor [7]. The sensor works as follows: it takes a full-bridge equal arm bridge as the basic circuit, with the sensitive components (a resistive foil strain gauge) as the bridge arm which is stuck on the metal cantilever elastic surface. When an external force plays on the elastic body, chip resistor subjected to tensile or compressive strain, and its resistance changes, which results in an out-of-balance on the bridge, generating a corresponding differential signal amplification circuit for subsequent measurement and processing [8]. Weighing module circuit diagram shown in Figure 6.

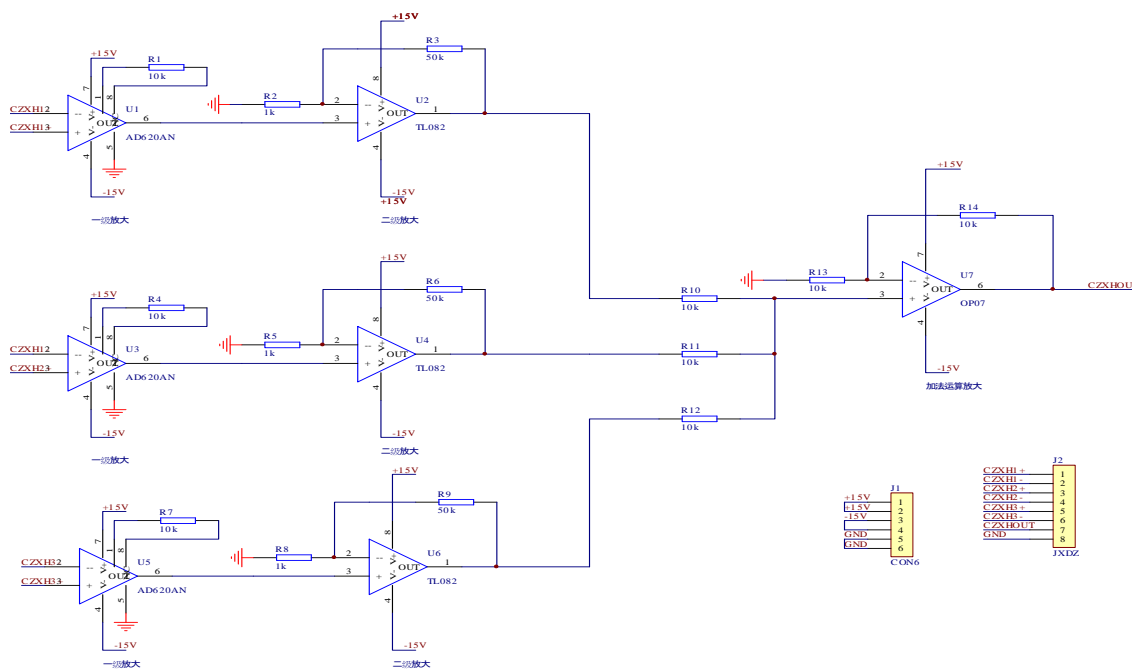

Figure 6. Weighing module circuit diagram

3.3. The Main Control Module and Communication Module

The function of the main control module is to receive and process signals coming from simulation objects detection module, weighing sensors and position machine. The communication module is used to connect the human-machine interface with main control module. And the two modules use the C8051F040 microcontroller as the core device [9].

The C8051f040 is a fully integrated mixed-signal System-on-Chip MCU, with 64 digital I/O pins and an integrated CAN2.0B controller. Its advantages are listed as follows: ① with a high-speed 8051 microcontroller core and pipelined architecture, most of the instruction execution time is one or two system clock cycles. ② With 4K internal RAM and 64K FLASH, it can meet the requirements for memory spaces in most designs without external memory devices, and thus simplify system design. ③ configure a variety of ports, such as SPI, SM Bus and UART. ④ supporting MODBUS protocol, you can be easily connected with touch screen [10].

C8051f040 can be coded by assembly language and C language, the system is coded by the C language, part of the code is as follows:

```

if(x[7]==0x01) // Single detection is completed
{
    x[7]=0x00;
    ADC0CN=0x00;
    water_last1=(x[17]*256+x[16]);
    if(water_last1<water_last0)
    {
        water_last1=0;
    }
    else
    {
        water_last1=water_last1-water_last0;
    }
    temp1=water_last1*2.74;
    water_last1=temp1/1;
    water_last1=water_last1;
}

```

```

x[14]=water_last1;
x[15]=water_last1>>8;
x[2]=0x00;
x[19]=0x01;
x[5]++;

water_ave=(water_ave*(x[5]-1)+water_last1)/x[5];
x[12]=water_ave;
x[13]=water_ave>>8;

EX0=0;
  if(x[5]==1)
  {
water_ave1=water_ave;
  }
  else
  {
water_ave0=water_ave1;
water_ave1=water_ave;
  }
  c=1;
}

```

3.4. Interactive Interface

Different with a previous PC as the position machine, this system adopts a new type of touch screen as the position machine. The system can make the equipment more flexible and reduce the investment, but also the operation is simpler and more convenient. The touch screen uses Delta's DOP---B07S411, and it is connected with the microcontroller through the MODBUS protocol [11]. The touch screen is used for the operation of the entire system, data display and data storage, at the same time, it can export the data through the U disk. The interface as shown in Figure 7, you can touch various options to complete the corresponding function.

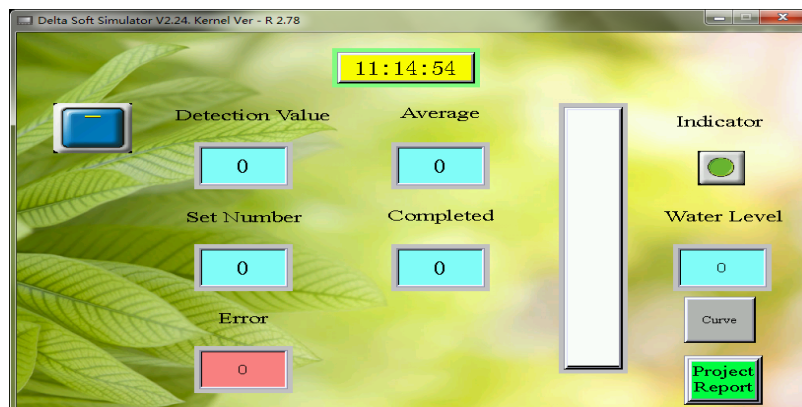

Figure 7.Touch screen operator interface

4. The Results and Discussion

Firstly, the water tank should be level, and the various parts of the wiring and piping should be connected. Then turn on the power supply, and establish a new project. Next we should put down the analogue and pour a certain weight of water into the pipe before clicking the start button. Until the water calm, we should click the finish button. Lastly, record the data on the touch screen. Repeat 20 times trial. Test data as shown in Table 1.

Table 1. Test results

Detection times	Actual weight (Kg)	Detection weight (Kg)	relative error (%)
1	0.5	0.52	4%
2	0.5	0.46	-8%
3	0.5	0.51	2%
4	0.5	0.48	-4%
5	0.5	0.47	-6%
6	0.5	0.51	2%
7	0.5	0.48	-4%
8	0.5	0.49	-2%
9	0.5	0.48	-4%
10	0.5	0.48	-4%
11	0.5	0.46	-8%
12	0.5	0.46	-8%
13	0.5	0.51	2%
14	0.5	0.51	2%
15	0.5	0.51	2%
16	0.5	0.46	-8%
17	0.5	0.53	6%
18	0.5	0.48	-4%
19	0.5	0.53	6%
20	0.5	0.51	5%

From the measurement results, the relative error of 20 times measurements are between -10%---10%, the accuracy reached to 90% which meet the expected requirement. Of course, the measurement results still exist some errors. And considering these errors, there are the following two points: ①The analytical formula theoretically obtained is got from the ideal situation. Such as the sensing coil axis symmetry, this condition can't be achieved in practice. ②In experiment, the induction signal extracted from the weighing system will be mixed a lot of interference signal, which will inevitably have a certain influence on the measurement results.

5. Conclusion

In general, in this paper, the sanitary ware subsequent water detection system can measure the measured target more accurately under EN977-2012 standard. There has a significant contribution to the guarantee of consumer rights and interests, also to maintain industry norm standards. But there are still some problems in the detection accuracy, such as anti-interference ability. The research of key technology problems will increase the added value of subsequent water detection system and the market competitiveness.

References

- [1] Zhao Jiangwei, Liang Baiqing. Chinese sanitary ceramics export barriers analysis. *Ceramics*. 2011; (5): 9-11.
- [2] He Mengke, Xiao Shengran, Zhou Haomin. Subsequent Water Testing in Toilet Capability Test System Based on Configuration Software KingView 6.51. *Industrial Control Computer*. 2007; 20(5): 36-38.
- [3] Feng Mengli, Cai Yuping, Song Chunrong. The Development and Comparison of Several Electromagnetic Nondestructive Detected Technologies. *Journal of Sichuan Ordnance*. 2012; 33(2): 107-110.
- [4] Wang Bo, Wen Weiming. "Six liters of water system," toilet water modeling structure and the relationship between research. *Ceramics*. 1998; (1): 45-47.
- [5] Dong Ke, Qian Yuxia, Yuan Zhangyi. Magnetolectric Speed Sensor to Detect Ultra-Low Frequency Vibrations. *TELKOMNIKA Indonesian Journal of Electrical Engineering*. 2013; 11(5): 2502-2507.
- [6] Meng Jian. Study on Key Technique of Electromagnetic Detection for Metal. Tianjin: Tianjin University Electrical Automation Engineering. 2008.
- [7] Wang Xian'an, Wang Xianyu. Design of a Kind of Pocket Electronic Balance. *Light Industry Machinery*. 2007; 25(2): 110-112.

-
- [8] Lu Ling, Yuan Baoshan, Li Yede. The design of electronic cashier scale based on C8051F350 computer. *Shandong University of Technology (Natural Science)*. 2009; 23(3): 81-84.
- [9] Wang Luyan, Shen Zhangguo, Chen Long. The Performance Analysis for Embedded Systems using statistics methods. *TELKOMNIKA Indonesian Journal of Electrical Engineering*. 2013; 11(7): 4099-4103.
- [10] Chen Ruitao, Gu Huadong, Zhen Chenqi. Touch-screen Control System of ns Ho: YAG Laser Based on C8051F040. *Microcomputer Information*. 2012; 28(9): 123-125.
- [11] Yuan Li, OuYang Mingsan, Jiang Ying. Design of Mine Feed Inverter Monitoring System Based on Delta Touch. *Coal Mine Machinery*. 2013; 34(4): 266-268.