

Application of Zigbee in Smart Home with Dynamic Routing Algorithm

Jia Meng*, Li Zhongqin

Department of Electrical Engineering, Xin Xiang University
East Jin Sui Street, Xin Xiang City, He Nan Province, China

*Corresponding author, e-mail: tianshi_cd@163.com

Abstract

In order to avoid damaging the walls and bore a hole through the walls, also to save the cost of rewiring, low voltage power line can be used to implement the smart home. However, several difficult problem must be solved at the same time, the most important are finding a technology method to suppress the noise interference and resist the weaker signal. The smart home system is introduced in the paper. During the design of Smart Home System adopting power line signal carrier, a dynamic routine algorithm based on the idea of Genetic Algorithm is proposed to cope with the time-varying and random feature of power line channel. Thus the system can find the transmission path in real time and dispatch the signal carrier to transmit among the nodes. With this algorithm, the communication between a certain group-controller and its terminal nodes or between the main-controller and the group-controllers is realized successfully. In the proposed algorithm all nodes but the controller adopt same driver, therefore the plug and play is realized for all nodes.

Keywords: routing algorithm, genetic algorithm, smart home system, Zigbee

Copyright © 2014 Institute of Advanced Engineering and Science. All rights reserved.

1. Introduction

Smart home is an efficient, comfortable, safe and convenient living environment which consists of networks communication, information application and equipment automation by using the house as its platform. It also consists of integrated system and service management software. With the development and maturity of power line signal carrier technology, the development and popularity of smart home will be promoted dramatically by introduction the power line signal carrier into smart home area. Three parts containing main-controller, group-controller and its terminal controller can be taken into the hardware of smart home adopting power line signal carrier [1]. The main-controller to group-controller, group-controller to group-controller, group-controller to its terminal nodes, terminal controller to terminal controller vary with the changing of power line path environment. When the signal fading are serious, a dispatch the signal carrier are needed to transmit among the nodes. In this paper, a dynamic routing algorithm based on genetic Algorithm are put forward to cope with the continuous varying environment of power line channel.

2. The Technical Features of ZigBee

As a kind of wireless communication technology, ZigBee has the following characteristics:

(1) Low power: ZigBee' transmission rate is low and its transmission power is only 1mW. It uses a low power consumption dormant mode, so the ZigBee equipment is very power saving. According to estimation, ZigBee equipment only needs two No. 5 batteries to last up 6 months to 2 years. It leaves other wireless devices dead in the water.

(2) Low cost: the initial cost of ZigBee module is around \$6 and it may fall to \$1.5-2.5 soon, and the ZigBee protocol is free of patent fee. Low cost of ZigBee is also a key factor [2-3].

(3) Short delay: communication delay and the delay of activation from hibernation are short, the typical search equipment delay is 30ms, dormant activation delay is 15ms, the delay of active device channel access is 15ms. The ZigBee technique is suitable for wireless control which is critical for delay (such as industrial control occasions).

(4) Large network capacity: a star structure of the ZigBee network can hold up to 254 slave device and a host device, a region can exist up to 100 ZigBee network at the same time, and the composition of network is flexible [4].

(5) Reliable: the system takes the strategy of avoiding collision, at the same time it reserves a special time slot for the communication services which need a fixed bandwidth to avoid competition and conflict while sending data. MAC layer adopts the data transmission mode confirmed fully, each of the transmitted data packet must wait the confirm information from receiver. If there are some problems in the process of the transmission, the data packet can be retransmitted.

(6) Safety: ZigBee provides the function of checking data packet integrity based on the cyclic redundancy check (CRC) to support authentication and authentication, using the AES-128 encryption algorithm, each application can flexibly determine its security property.

To nervous energy demand, ZigBee has its own advantages, replacing cable with wireless can save cable cost, and low power consumption can also save the power demand, which is consistent with current trends. A routing network can enlarge the coverage of the communication area. Compared with the Bluetooth, infrared point-to-point communication, and WLAN Star Communications, ZigBee RS232; ZigBee RS485; ZigBee Ethernet derivative products can achieve the communication transmission between any two points in the network, which makes its range of applications wider. It has many practical applications in many fields, such as the industry control, wireless sensor monitoring, personnel wireless positioning and other places.

The overall scheme of system design is shown in Figure 1. The system mainly consists of two parts: wireless network node and the GSM / GPRS gateway. The system contains three nodes: Menci anti-theft node, infrared burglar alarm and fire alarm node.

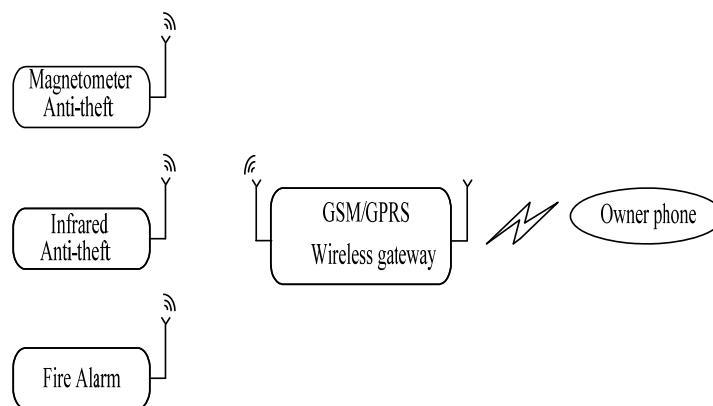

Figure 1. Intelligent home furnishing wireless messaging security system as a whole design scheme

All the core chips in the design of system select the CC2530 chip from TI; CC2530 is the latest generation ZigBee standard chip launched by TI, which is fit for 2.4GHz, IEEE, 802.15.4, ZigBee and RF4CE. CC2530 includes the class RF transceiver with excellent properties, industry standard enhanced 8051 MCU, system programmable flash memory, 8KB RAM and many other powerful features so that it can be widely used in the 2.4-GHz IEEE 802.15.4, RF4CE remote control system, ZigBee system, home / building automation, lighting systems, industrial control and monitoring, low power wireless sensor networks, consumer electronics and health care.

2.1. GSM / GPRS Gateway Design Overall Scheme

The GSM/GPRS gateway design is shown in Figure 2. CC2530 chip and NRF905 wireless transceiver module is the core of gateway. NRF905 wireless transceiver module receives the sensor information from each node and sends the information to the CC2530 chip.

CC2530 chip displays information of each node in the LCD, and provides warning for home users through LED and the buzzer, then the alarm information is sent to the GSM/GPRS module through the serial port and eventually sent to the remote user [5-6].

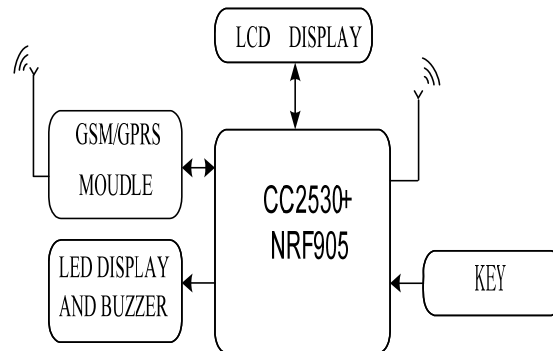

Figure 2. The GSM / GPRS gateway design

In addition, according to the need, it designs a 4 x 4 touch key for the gateway to modify the gateway electronic password and alarm mobile phone number, and designs an emergency alarm button. Key information is sent to CC2530 after treatment by the detecting chip CP2532/CP2528. CP2532/CP2528 is capacitive touch button detection chip with 12 / 8 key, and it can implement.

2.2. Node Design

The design of nodes in the system uses uniform design (as shown in Figure 3). The wireless transceiver module and CC2530 chip consist of wireless network nodes. Wireless transceiver module is responsible for communication between the nodes and a gateway, CC2530 chip is responsible for handling and analysis of sensor information.

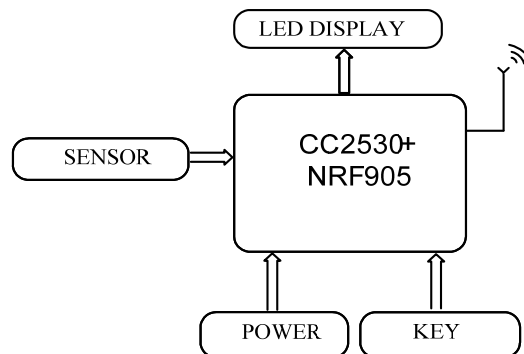

Figure 3. Node design

Menci anti-theft node uses MC31 magnetic sensor which doesn't require external to supply power and output a switch whose threshold is 16mm according to the distance of a magnet and a dry reed pipe .This design uses the boosting pump technology to supply voltage for CC2530 chip. As long as the external voltage exceeds 1V, the circuit can work normally, thus it contributes to the stable operation of circuit for a long time.

Infrared anti-theft node uses piezoelectric infrared sensor LHI968 whose working voltage is 2 ~ 15V, output signal amplitude is about 1mV, frequency is 1Hz. The sensor can monitor the course of external heat source objects (such as the human body or certain part). In view of the weak sensor signal , the general design uses special processing chip (such as BISS0001) to process the sensor signals, by which output signal is stable and responsive, but

the external circuit is complex, large power consumption, high cost. In this paper the design doesn't process the sensor signals by the sensor signals, but by CC2530 chip directly, this method greatly simplifies the design of circuit, reduces the power consumption and saves cost.

Fire alarm joint simultaneous uses temperature sensor LM35 and the infrared receiving tube to monitor. Temperature sensor measures the environment temperature, and the infrared receiving tube monitors fire and heat source. This design is simple, low cost, and suitable for smart home system.

3. The Routing Algorithm Adopting Power Line Signal Carrier in Smart Home System

The intelligent home control system based on zigbee networks includes three parts. The main controller is the control center of the system, while the middle controller is set to every room to sent message and the terminal controller is the based controller to control each machine. The main controller, middle controller and the terminal controller are all called points. The main controller aimed to send command to live wire entanglement through some middle controller. An answering signal will be transmitted to the main-controller through the middle controller after the received signal has been tested correct. The communication of group-controller and its technical nodes are similar with this style. In this paper, the communication of middle-controller nodes its terminal nodes in single room will take as an example to illustrate an routing algorithm which finds a stable transmission path between group-controller and its terminal nodes, the group-controller nodes are coded as "0", this number will be used as the physical ID of nodes [7].

As the few nodes in single room ,the roll-call polling style can be taken to communicate among all nodes (contain group-controller and its terminal nodes) in order to avoid the signal conflict in power line. It refers to connect all nodes to the specific node to communicate in turn, if there is not a request, it will turn the next node. In addition, the routing algorithm designed for signal carrier must cope with the time-varying and unknown feature of power line channel. The plug and play is realized for all nodes.

3.1. The Solve of Network Routing Problem by Genetic Algorithm

The purpose of network routing problem is creating a routing room from the signal source node to the goal node, at the same time making the property of network reach to the maximum and the cost of communication reach to the minimum. A network can be regarded as a undirected weighted graph $G = (V, E)$. The "V" can be understood as the set of node, and the "E" can be understood as the set of path. The genetic algorithm can be taken to solve routing problem after defining the signal source node and the goal node.

(1) The design of code

The path information from the "i" node to the "j" node can be expressed by

the " a_{ij} ", $1 \leq i \leq N$, $1 \leq j \leq N$, (the "i" "j" indicate the integer value in conditions, the "N" is the total number of nodes in network). For example, the " a_{ij} " indicate the path information from the "i" node to the "j" node, if it is zero, it will express that there is not direct path between the two nodes . If it is not zero, it will indicate a path which weighted value is a_{ij} between the two nodes .So every individual can be understood as a set of sequential points which has substantial path from the start of source node to goal node .

(2) The generation of initial group [8-10]

1) Firstly, finding the relationship between each point and another point, then to find out the number which is from this point to other points and store them in an array, at the same time to save the related path information.

2) Set a collection of individual points, each individual is initialized to zero individuals.

3) When initializing, start from the first note. First to determine whether or not there is a direct connection between the current node to the next note. Without any connection ,the initialization of the individuals can be finished. If there is a connection, then randomly select a node from the existing node, and regard it as a new node. Then repeat operation until completing the initialization of the individual. Other individuals need to be initialized in the same way, and finally the initialization of the entire group can be completed.

(3) Genetic Algorithm fitness function.

Judging the connection status of the path between two points based on the path information indicated by the individual. If the connection between two points don't reach to the final point, adding the routine weight value between two points to the adaptive value. If there is no connection, adding the penalty value to the adaptive value; Saving the adaptive value of individuals to proceed priority selection. Do this for every individual, until completion of the entire population's fitness .Finally, to determine whether to update the (current) best path information based on the results.

Algorithm selection mechanism can be completed by using the fitness proportion method(that is roulette wheel selection). In the roulette wheel selection mechanism, each individual's selective probability and it's adaptive value are directly proportional.

Set up the size of the group as n , the fitness of individual i as f_i , then the selected probability of i is:

$$P_{si} = f_i / \sum_{i=1}^n f_i \quad (1)$$

The probability reflects the proportion of the individual fitness in the whole group. The greater the individual fitness, the higher its probability is selected. After calculating the probability of each selected individual in the population according to the above formula, the determination which individuals are chosen can be made.

One-point Crossover can be used, but some paths which dose not actually exist will appear after cross path. Some limit measures need to be taken to prevent the appearance of the path which doesn't exist after crossing. And the new individuals can meet the conditions by being amended accordingly.

Also conventional mutation strategy can be taken to modify the individual after variation according to the certain position, to prevent the appearance of paths which do not exist and program exception.

3.2. Characteristics of Genetic Algorithm

The routing update algorithm proposed in this paper will draw on the idea of genetic algorithm to design the carrier signal transmission path searching algorithm. By applying the basic framework it solves the network routing problems. There are differences between this method and the general genetic algorithm: due to the power line channel environment is changing, there is no best signal transmission path related with the time among nodes. To establish the routing information table and initializes it by the routing update algorithm proposed in this paper. The algorithm can determines whether there is a connection between the junction point by controlling and confirming the transmission of signals. The initialization of an individual can be seen as a path generation process. Each individual fitness is defined as the reciprocal of the sum of path weight .The litter the sum of all weight are, the higher quality the individual is, and the greater the adaptive value will be. Through solving the group fitness during the process of system operation (selection, crossover and mutation), the best path (individual) to the current power line channel environment is being searched constantly, and the routing information table in being updated in time.

4. The Construction of Routing Information

The routing information table in the dynamic routine algorithm is a timely updated matrix which records the environmental condition information of power line channel. Routing information table performs the population's fitness solving each time after controller finishes control operation. In order to respond the varied environment of power line channel, routing information table need to determine whether to update (alter) itself based on the solving of population's fitness processed each time after controller finishes control.

If the system has N nodes (including group controller and terminals), the routing information table is an $(N + 1) * (N + 1)$ -order matrix. The process of the establishment of the routing information table is shown in Figure 4.

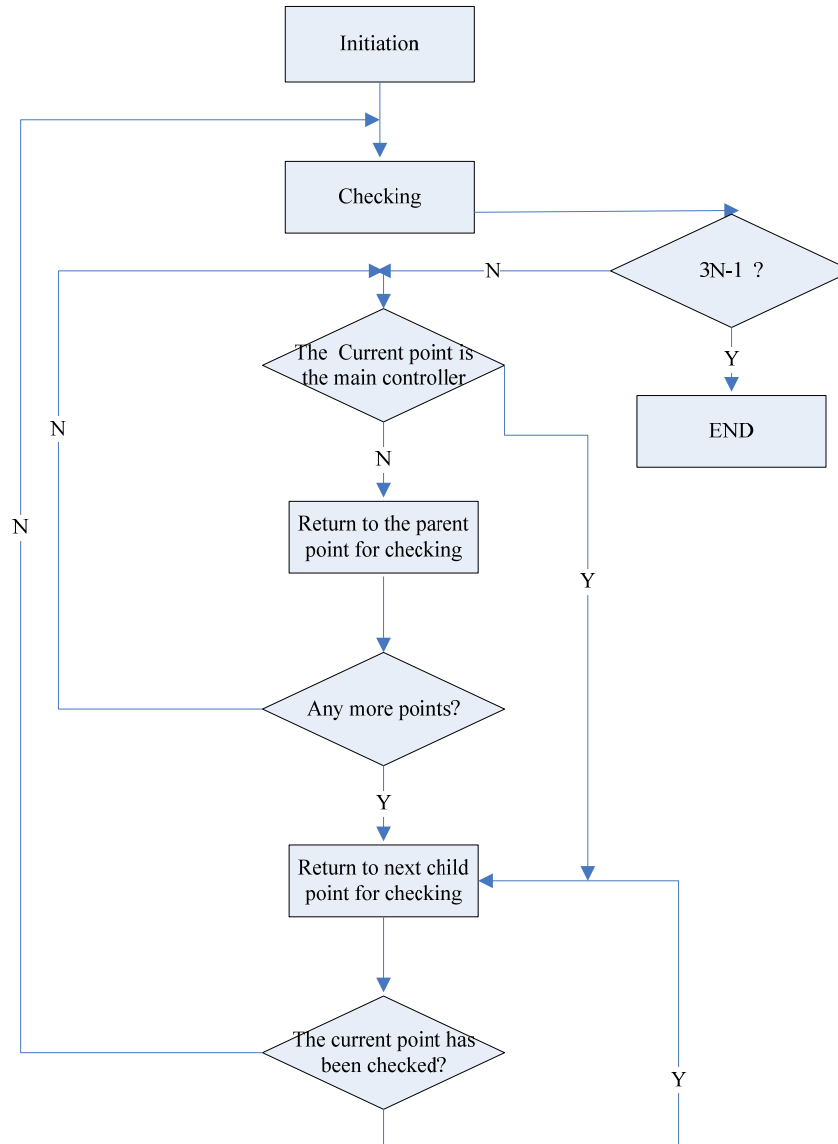

Figure 4. The foundation of routing information

The flowchart description:

Initialization operation. The routing information table is established by system based on the number of nodes. If the system has N nodes (including group controller and all terminals), to create a matrix A $(N + 1) * (N + 1)$ -order. The elements $a_{0,j}, a_{i,0}$ in the first row and column in the A value from small to large depend on the physical ID value of the node, where $i, j = 1, 2, \dots, n-1, n$. The elements in matrix A apart from elements in the first row and the first column will represent the direct communication between the node i and node j on the road, where $i = 0, j \neq 0$. $a_{i,j}$ is an integer valued between 0 to 255 which means no information in the road of i and j when it values 0 and the communication in the road i and j achieve the best. In the empty routing information table, $a_{i,j}$ value 0, where $i, j = 1, 2, \dots, n-1, n$. After initialization, group controls have the polling right.

(2) "Polling" operation. The current node with polling right and being not polled sends a polling signal. The receiving node polling signal sends a response signal. A node can respond a plurality of polling signal. Polling communication mode avoids the conflict between power line

signals. If the node i receives the response of signal node j , the elements of the matrix will set the initial value, which means node i and node j can directly communicate. Node i is regarded as parent node of node j and node j is considered as child node of node i .

(3) "To 3N-1" judgment. When there are 3N-1 elements is non-zero, the routing information table is created. The 2N elements in first row and first column of the matrix are the values for the physical node ID. When terminal node response is received by groups control, the corresponding element in the matrix is set as initial value, and the terminal node receiving the response signal means it has been found a direct or indirect transmission path by which group control and terminal nodes can communicate with each other. Each terminal node is only one answering. Therefore, when there are 3N-1 element is non-zero in the routing information table, there will be N-1 elements to be set as the initial value because of the receipt of the response of the corresponding terminal node. The group control has found all transmission paths which can reach the terminal node, and the routing information table is created.

(4) "Polling returned to the parent node" operation. If the physical ID of the current node which has a right to polling is s , then searching the $s + 1$ columns and looking for the non-zero elements, where $r \neq 0$. Node s return polling right to its parent node r .

(5) "There are more child nodes" analyzing. If the physical ID of the node with polling right is r , the physical ID of the node just returned to polling right is s and search the $r + 1$ column. Whether node r has more child nodes depend on the non-zero elements bellow the ($s + 1$) column.

(6) "Polling a child node to the next" operation. If the physical ID of the current node with the polling right is s , the physical ID of the node just returned to the polling right is s , then search for the $r + 1$ row of the matrix and find the first non-zero element bellow the ($s + 1$) column. Changing the node r delivers polling right to its child node t .

(7) "Polling to the first child node" operation. If the physical ID of the current node with the right to polling is r , then search fo the $r + 1$ line to find a second non-zero elements and change the node r delivers polling right to its child node s .

5.The Implement of Routing

There are five steps to implement routing algorithm: searching paths, judging paths, choosing paths, transmitting signal, updating the router table.

While the router table is established based on the dynamic updating routing algorithm and the nodes response to multiple polling signals, the amount of the paths from group controller to any terminal should be more than one. So when the certain node is the target node, we search the router table to find the set of all the paths from all group controllers to the target node. The process finding all the sets of paths from the group controller to a target node is showed in Figure 5.

After finding all the paths from the group controller to a target node, we judge and choose among them. According to the algorithm in this paper, an individual adaptive value represents the channel condition of each path. It is definite as the reciprocal of the sum of the path's all weights. A sum of the paths's all weights reflect the number of relay nodes. The more the relay nodes are, the longer the time which controlling signal and acknowledgment signal transfer costs, which increases the load of the network. Thus we choose the path having the fewest relay nodes. In conclusion, the adaptive values are chosen as evaluation criterion. The bigger the adaptive value is, the better the path is. The algorithm determines whether there is a connection between nodes by the transmission of controlling the signal and acknowledgment signal. The initialization of an individual is seen as a generation of a path. During the processing of the system, by these individual genetic operations such as selection, crossover, and mutation we get the optimal path on the current electric environment. This is the process of choosing the path. After finishing choosing a path, the group controller sends a control signal. The signal arrives the destination node with the help of relay nodes along the chosen path. Once the destination node gets the control signal, it sends the acknowledgment signal, which returns to the group controller along the same path with that of the control signal. If there are no problems in the process of signal transmission, the group controller will receive the acknowledgment signal within the given time .

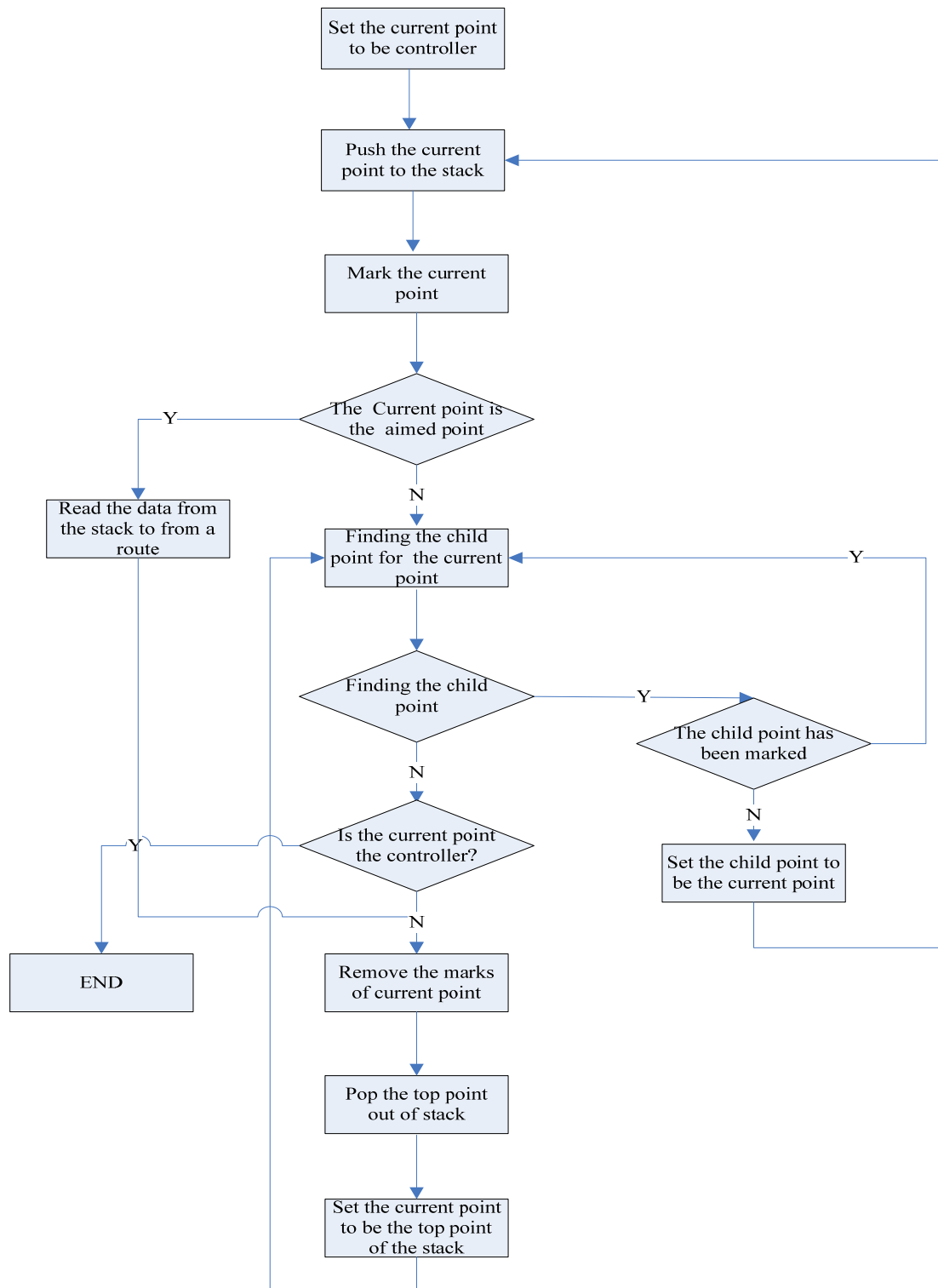

Figure 5. Routes searching process

In this paper, the value of each element in the routing information table represents the capacity of transmitting carrier of each route. If the carrier signal can be successfully transmitted through on a route, the value of element which represents the current route will need to be increased expressing the current route more reliable. Suppose that we choose a path by

probability that is $1 \rightarrow r \rightarrow n \rightarrow r(n-1) \rightarrow \dots \rightarrow r1 \rightarrow t$, then make $a_{1,m} = a_{1,m+2}$, $a_{m,r(n-1)} = a_{m,r(n-1)+2}$, \dots , $a_{r1,t} = a_{r1,t+2}$. If the sum of $a_{1,m}$, $a_{m,r(n-1)}$, \dots , $a_{r1,t}$ surpass 255, make $n=255$.

If the host can't get the acknowledgment signal during a certain time, it is defined as a failure transmission. The transmission path which carrier signal pass through is relatively unreliable, so we decrease the value that represents the routing information of all the paths, and it equals adding a penalty value to the individual adaptive value. If the available path is $1 \rightarrow r \rightarrow n \rightarrow r(n-1) \rightarrow \dots \rightarrow r1 \rightarrow t$, the function can be gotten as:

$$a_{1,m} = \lceil 0.8a_{1,m} \rceil, \quad a_{m,r(n-1)} = \lceil 0.8a_{m,r(n-1)} \rceil, \quad \dots, \quad a_{r1,t} = \lceil 0.8a_{r1,t} \rceil \quad (2)$$

After updating the routing table, the paths can be judged and chosen according to data in the routing information table, and the controlling signals are transmitted across the new chosen path.

6. Conclusion

The implementation of smart home by using power line signal carrier emphasizes to resist the much weaker signal in power line and succeeds in realizing the normal communication. A dynamic routine algorithm based on the idea of genetic algorithm is designed in this paper. The time-varying and unknown feature of power line channel can be coped with by this method in practice, and also the plug and play is realized for all nodes. The future research will focus on optimization algorithm and improve the efficiency of communication.

References

- [1] Wang Bo, Huang Peiwei, Zhong Youping. The smart home system adopting power line signal channel. *Telecommunications*. 2007; 47(2): 140-143.
- [2] Song Qian. The design and development of smart home adapting power line communication technology. Beijing. China Electric Power Research Institute. 2008.
- [3] Fahmi Fardiyan Arief, Muchlas, Tole Sutikno. AT89S52 Microcontroller Based Digital Compass with Voice Output. *TELKOMNIKA Telecommunication Computing Electronics and Control*. 2008; 06(1): 1-6.
- [4] The design of lighting control system adapting power line signal carrier communication technology. Hang Zhou. *Zhe Jiang university*. 2006.
- [5] Jiang Wuxue, Li Chengyin, Li Liming. The solve of network shortest path adopting genetic algorithm. *Sha He Teachers college*. 2007; 39(5): 39-41.
- [6] Xu Dianguo, Mou Yingfeng, Liu Xiaosheng, et al. *Reliable distributed power line communication networks for new public lighting management system*. IEEE International Conference on Industrial Informatics, Banff, Canada. 2003: 73-78.
- [7] Chen Xi, Cai Hui, Liu Lin. The management of path genetic algorithm. *Chang Sha Insitute of traffic*. 2005; 21(4): 76-80.
- [8] M Khairudin. RBFNN Control of A Two-Link Flexible Manipulator Incorporating Payload. *TELKOMNIKA Telecommunication Computing Electronics and Control*. 2010; 08(2): 157-164.
- [9] P Srikanth, Ashwani Kumar Chandel. Inverse S-Transform Based Decision Tree for Power System Faults Identification. *TELKOMNIKA Telecommunication Computing Electronics and Control*. 2011; 09(1): 99-106.
- [10] Anton Setiawan Honggowibowo. A Web-Based Rice Plant Expert System Using Rule-Based Reasoning. *TELKOMNIKA Telecommunication Computing Electronics and Control*. 2009; 07(3): 187-194.