

# Design of Wireless Intelligent Video Surveillance System Based on 3G Network

Qigui Zhang<sup>\*,a</sup>, Yu Chen<sup>b</sup>

College of Information Engineering, Taiyuan University of Technology, Taiyuan 030024, China

<sup>\*</sup>Corresponding author, e-mail: [zhang\\_qg63@hotmail.com](mailto:zhang_qg63@hotmail.com), [chenyu1313@126.com](mailto:chenyu1313@126.com)<sup>b</sup>

## Abstract

Depending on the development of embedded technology and mobile communication network, an intelligent wireless video surveillance solution based on the 3G network and HI3515 is proposed in this paper. The front-end of the surveillance system is composed of HI3515 and SIM5216E, which integrates intelligent video analysis, intelligent control, and other functions. It has realized only transferring the useful video surveillance information-abnormal event information, setting the special receiver that will receive the surveillance information, and transferring the surveillance information according to user's commands. Surveillance scene information database has been established on the video surveillance center. According to the surveillance video data received from the front-end of the surveillance system, the corresponding electronic map and the surrounding information can be obtained and multi-channel surveillance can be realized as well.

**Keywords:** 3G, HI3515, Intelligent video surveillance, Embedded system, SIM5216E

Copyright © 2014 Institute of Advanced Engineering and Science. All rights reserved.

## 1. Introduction

In modern society, video surveillance system has provided the convenience and security for all aspects of people's life [1].

The emergence of 3G network has greatly improved the data transfer rate of the mobile network. Union WCDMA network, for example, can provide the maximum data transfer rate of 384 KBPS for users under the condition of 5 MHz bandwidth and the transfer rate can be up to 2 MB/s within the local area network. While during the period of the GPRS network, the maximum data transfer rate is 171.2kbps, and the maximum data transfer rate of the EDGE network as GPRS enhanced version is only 473.6Kbps [2]. Compared with the video surveillance scheme based on GSM/GPRS network, The 3G video surveillance scheme which depends on the advantages of high bandwidth of 3G network improves the transmission quality of the video surveillance information and strengthens the instantaneity of surveillance, but transmits the real-time video data indiscriminately, consuming the very large data flow and accordingly producing the high data traffic costs. So it is not conducive to the application and promotion. Corresponding to the above problems, a 3G video surveillance system with the functions of intelligent video analysis and transmission control is put forward in this paper. According to the intelligent video analysis algorithms, the front-end of surveillance system can analyze the video data captured by the camera, store the useful information to local memory, and through the 3G network send the useful information stored to the receiver that is set in advance. The front-end of surveillance system can receive the control information sensed by users and then determine the transmit mode according to the content of the information, such as sending pictures or video clips, etc. This improves the flexibility of the system and also greatly reduces the costs during transmission of using 3G network. In addition, surveillance scene information database has been established on the PC user terminal. According to the surveillance video data received from the front-end of the surveillance system, the corresponding electronic map and the surrounding information can be obtained and multi-channel surveillance can be realized. HI3515 is a kind of video surveillance application chip researched and developed by HiSilicon Company, which carries a high performance ARM9 processor core and integrates the video hardware acceleration engine, improving the video chip processing capacity greatly. Meanwhile, HI3515 supports H264 and M-JPEG codec standard, etc., so it can meet the requirements of the video format of wireless surveillance system. A

video surveillance solution based on Hi3515 and 3G network is proposed in this paper, which has realized the design of hardware and software of the whole system, and increased the function of intelligent video processing and intelligent control.

## 2. Surveillance System Overall Scheme

This surveillance system is mainly composed of the video surveillance front-end, mobile phone terminals, the video surveillance center and FTP server terminals. The overall structure of the system is shown in Figure 1. It implements the basic functions such as video capture, video analysis, video compression, video transmission and system control; Combined with the 3G wireless network, only when an exception occurs, the surveillance front-end will automatically send alarm image to mobile terminal, and at the same time abnormal video data will be transmitted to the video surveillance center; The user can login email and FTP server through the PC terminal to view the video data collected from the front end, according to need, can send control messages to the front-end by mobile phones to request to send video data; the PC terminal with a specific surveillance system can be used to get the electronic map and the surrounding information of the surveillance front-end. In addition, through visualization manipulation interface, controlling the surveillance front-end in real time can be realized.

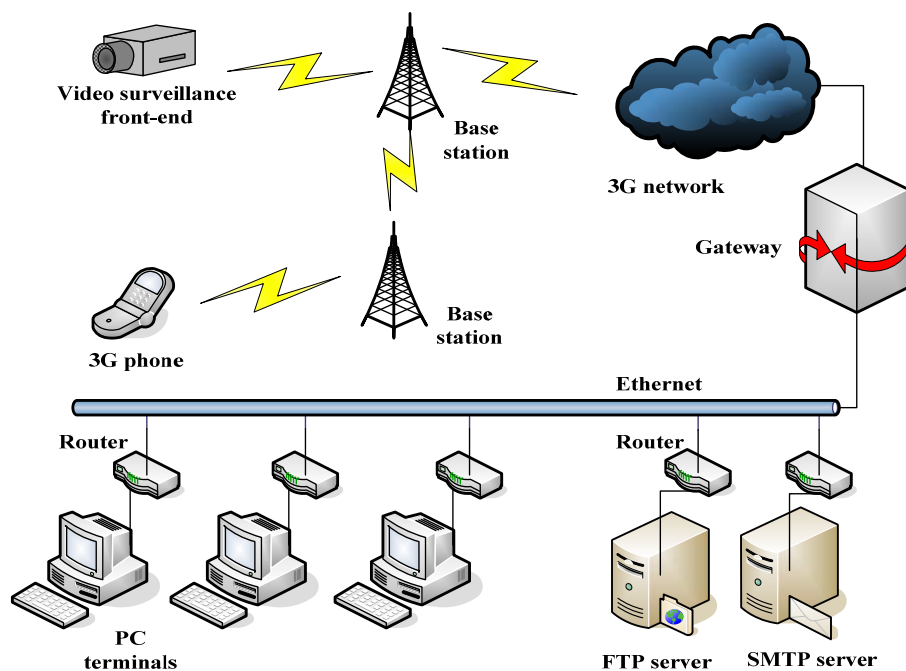

Figure 1. The Overall Structure of the System

### 2.1. Video Surveillance Front-end

The video surveillance front-end mainly consists of video server and 3G module. The video server mainly refers to the embedded system which is based on Hi3515 chip and Hilinux operating system. SIM5216E is a 3G module which supports multiple frequency bands, including WCDMA, and integrates many network application protocols, including MMS/TCP/IP/SMTP/FTP, etc. The main function of video surveillance front-end: After power on the front end, 3G module which has inserted the USIM card will search the mobile network to register firstly, and will access to 3G mobile networks after registering successfully; The video data captured by the camera will be transferred to Hi3515, and through intelligent algorithm analysis, video acquisition front-end which takes Hi3515 as the core will trigger both the JPEG and the H264 to code the video data when abnormal events occur and the encoded data will be stored locally; Hi3515 will transfer the video data stored locally to 3G module, then the data will

be packaged with network protocols by 3G module and sent to the mobile network [3]; In addition, through intelligent control program video surveillance front-end realizes that sends video data to the user regularly and according to the user's request to send data, which will improve the convenience and flexibility of system application.

## 2.2. Mobile Phone Terminals

Mobile phone terminals mainly refer to the user's phone with MMS function. When abnormal events occur, mobile terminals will receive alarm image sent by video surveillance front-end, the user can conduct a preliminary judgment according to the content of the MMS, and choose whether to log in the PC terminal for further checking.

## 2.3. Video Surveillance Center

The video surveillance center refers to a personal computer with operating system and is able to connect to the Internet. The software of the video surveillance center based on browser/server communication mode, realizes log inning email address and a specific FTP server by webpage. Through user authentication mechanism, users can view the abnormal events video data, and also can be in alternative to delete or store the data locally; On the specific PC system that integrates the surveillance application system, the system surveillance scene information database is established, and according to the received surveillance video data, it can obtain the electronic maps and the information around of the surveillance scenario; cooperated with the multiple window display, it can realize multiple monitoring.

## 2.4. FTP Server Terminals

The FTP server terminals use the PC operating system to realize the construction of the FTP server and router settings. Making different folders corresponding to different surveillance front-end for the FTP server can realize multi-channel video surveillance.

If the FTP server uses the internal network, we must set the parameters of the router to make an external network able to access to the FTP server which is set up in the internal network. In general, there will be options named NAT or forwarding rules in the router settings page, and we can find the option named "Set DMZ host IP address" in the Sub Menu. Set the IP address as the FTP server host IP and enable it. Then the IP address of the FTP server will be exposed to the external network.

## 3. Hardware Design of the Video Surveillance Front-end

The hardware circuit of video surveillance front-end uses the Hi3515-H264 codec processor which is researched and developed by HiSilicon company as the master controller chip, and uses SIM5216E wireless communication module which is researched and developed by SIMCOM Company as the 3G module. DC-Camera uses CMOS Camera module who's CMOS sensor is MT9D111 researched and developed by the Micron Company. The hardware circuit is mainly composed of Hi3515 main control circuit, the 3G communication module interface circuit, video interface circuit, stabilized voltage supply circuit, real-time clock circuit, reset circuit, system debugging circuit [4] [5], etc. The overall structure of the hardware circuit is shown in Figure 2.

Hi3515 is a multi-core, high-performance, highly integrated SOC communication media processor which is integrated with the ARM926EJ core, video codec, video hardware acceleration, and image processing module. The working frequency of the ARM926EJ core is up to 400 MHZ. It has both instruction and data cache with 16KB and Built-in MMU, which ensures the surveillance system to run faster and work stably. Hi3515 supports many kinds of video input interface including Digital Camera and has abundant peripheral interfaces at the same time, including the UART, SPI, GPIO, etc. The main control circuit of Hi3515, which is the core of the video monitoring front-end, is responsible for the whole system working normally, and controlling the peripheral circuit correctly. NAND FLASH storage equipment selected by this system has a capacity of 1 GB. It respectively stores uboot, the Linux kernel, video analysis, application of intelligent control and abnormal events video data that has been encoded and compressed.

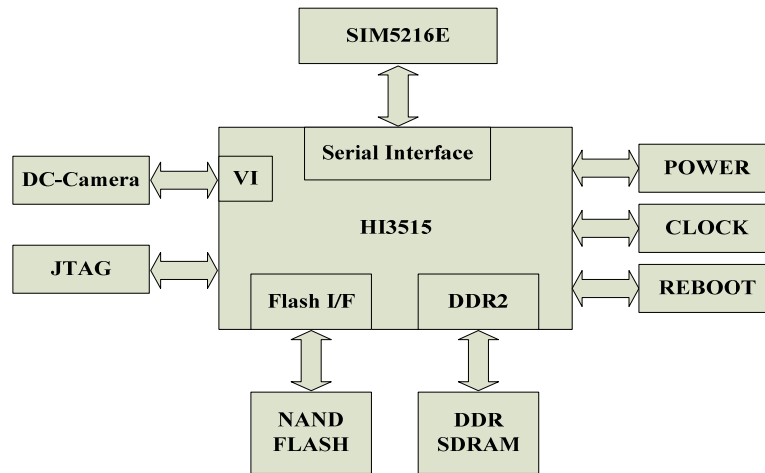

Figure 2. The Overall Structure of the Hardware Circuit

Choose 2 pieces 16 bit DDR2 to constitute a 32 bit DDR2, and the capacity of each DDR2 is 256 MB. This is enough to guarantee the reliability of the system when it runs large amounts of data. Reserving the JTAG interface is responsible for the hardware debugging.

The 3G module SIM5216E of this system supports HSDPA/WCDMA/GSM/GPRS/EDGE, and HSDPA down link data transfer rate is up to 3.6 Mbps. It can be widely applied to all kinds of 3G network application solutions [6].

The reason for selecting this module:

- It has two work modes for choosing: Double-frequency UMTS/HSDPA 900/2100MHZ and three frequency GSM/GPRS/EDGE 850/900/1800 MHZ.
- In the interior of the module, it integrates a variety of application features, including supporting for embedded LUA scripts, TCP/UDP/FTP/HTTP/HTTPS/SMTP/POP3/MMS protocol and abundant AT command, reducing the difficulty of the secondary development.
- It has rich peripheral interfaces: USB2.0, UART, USIM card, ADC, digital camera interface, GPIO, I2C, Micro SD card and so on, increasing the application flexibility and scalability of the module itself.
- Support voltage range: 3.3 V ~ 4.2 V, conforms to the power supply design specification of the video surveillance front-end. The interface circuit of 3G module is mainly composed of the power management circuit, network status indication circuit, serial communication interface circuit and the USIM card interface circuit [7] [8], etc. Interface circuit structure of 3G module is shown in Figure 3.

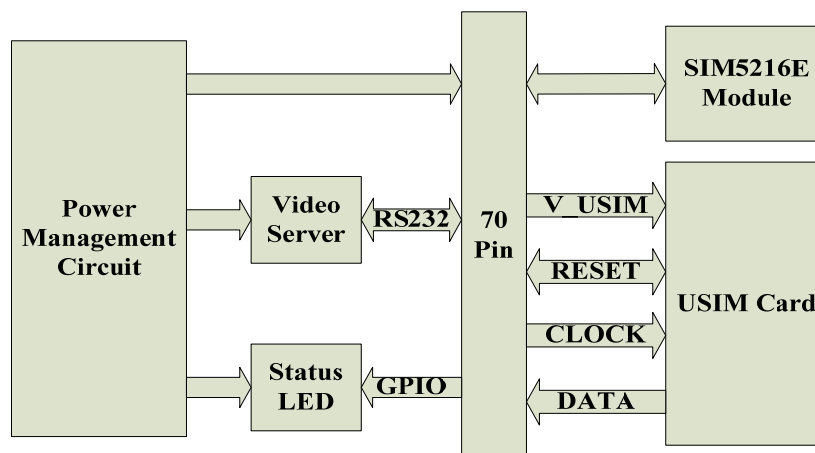

Figure 3. Interface Circuit Structure of 3G Module

## 4 Software Design of the Video Surveillance Front-end

### 4.1 Software General Structure

HiSilicon Company provides the matched software development kit---Hi3515SDK for developers. It contains the uboot source files, Hilinux system kernel source code files, the busybox tools for making root file system, as well as dedicated cross compiling tools---arm-hisimall-linux-gcc, and Hi3515 chip allows users to call itself rich API interface function, making it convenient to set up the system operation environment and complete the application development [9]. The overall structure of system software is shown in Figure 4. It included the uboot initiator program, the relevant hardware driver, Hilinux operating system, and the application. The environment of Linux server is Red Hat Enterprise Linux 5.5 issued by the RedHat Company. This system is mature in technology, rich in resources and very suitable for embedded development based on Linux system.

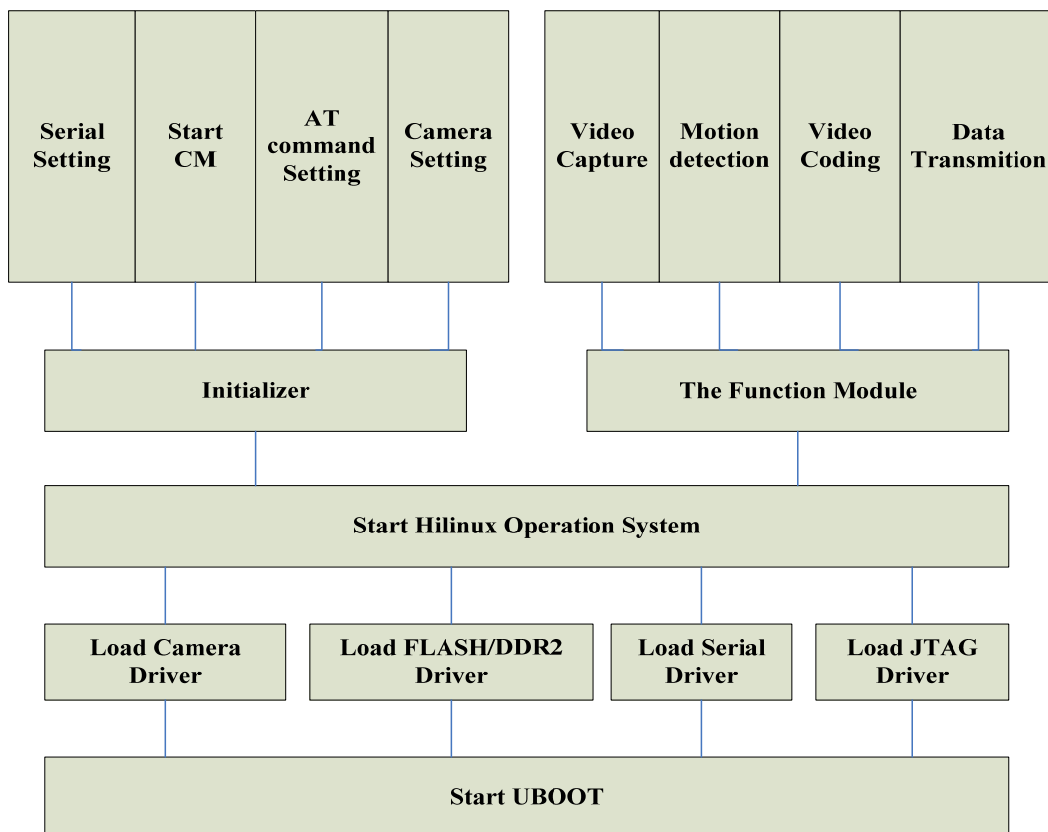

Figure 4. The Overall Structure of the System Software

### 4.2. Hilinux Kernel Configuration and Compilation

After the SDK development tool is installed on the Linux server. Hilinux system kernel source files will be generated in the source/OS directory. In the kernel source folder, execute the following command to complete the kernel configuration tasks:

- hisilicon\$make mrproper
- hisilicon\$make menuconfig

The "make mrproper" command is optional for clearing up the files generated in the previous kernel compilation. If it is the first time to build the kernel, this step can be omitted; If the "make mrproper" command is to be executed, config file must be reloaded again. Specific steps are as follows [10]:

- make menuconfig;
- select "Load the an Alternate Configuration File" menu item;
- input the arch/arm/configs/hi3515v100\_full\_release\_defconfig;

- choose the required module;
- save and exit;

After the configuration is saved, input the "make" command to compile the kernel directly. The kernel image file will be generated in the arch/arm/boot directory after completion of compilation, including compressed zImage file and uncompressed image file.

Generally, use the former. Because the "bootm" command will be used when boots the kernel in u-boot, the developer must use tool mkimage to deal with the zImage file. Specific operational command is as follows:

- hisilicon\$ mkimage -A arm -T kernel -C none -a 0xc0800000 -e 0xc0800000 -n hilinux -d arch/arm/boot/zImage hikernel;

After the above command execution, the file named hikernel will be generated under the current directory. This file is namely the kernel image file which is needed to be downloaded to the NAND FLASH.

### 4.3. The Software of Capturing Abnormal Events Images

According to different applications, you can choose the corresponding video analysis algorithms, realizing the capture of abnormal events [11]. Camera constantly captures the video data of the surveillance scene, and transfers the data to the Hi3515 for analysis. If there are abnormal events, it will trigger the encoding and storage procedures and then realize encoding and compressing the captured video data, which will be stored in the local memory at last. The following example based on the motion detect algorithm.

The software mainly includes three parts: video data collection, video data encoding and video data analysis. CMOS camera connects a video input channel in Hi3515, and video coding channel group can be bound to the video input channel. Because Hi3515 supports double stream mode---one is the main stream, and the other is the secondary stream, two threads can be created successively after completion of the binding. One is the main stream for the JPEG coding channel and the other that is the secondary stream for the H264 coding channel. Both of them will be registered to the video coding channel group, then start the motion detecting function of the two coding channels to analyse the video data. If the motion detecting result is bigger than the threshold which has set the value in advance, it will trigger the preservation program, and save the data to the local. The function of software processes is shown in Figure 5.

### 4.4 The Software of the Sending of Abnormal Video Data

This part mainly realizes sending the local abnormal video data to the user terminal. According to the requirements, three receivers have been designed for this system: user mobile phone, email and FTP server. The size of JPEG images which have been saved to the local are generally within 100KB, which is conform to the restricted condition of the MMS, saving ten frames; the size of every H264 video clip is 6M, and the time is 1 minute. The two kinds of video data are corresponding to two threads. Under each thread, Hi3515 is continuously testing whether the local video data is generated. If video data is generated, firstly Hi3515 will send the AT commands related MMS to SIM5216E via the serial port, and the JPEG images will be downloaded into the SIM5216E; After the completion of sending MMS, Hi3515 will send the AT commands related SMTP to SIM5216E, and send the JPEG images to the email boxes of users; Finally Hi3515 will send the AT commands related FTP to SIM5216E, and send the H264 video clips to the special FTP server for users to download to check. The function of software program flow diagram is shown in Figure 6.

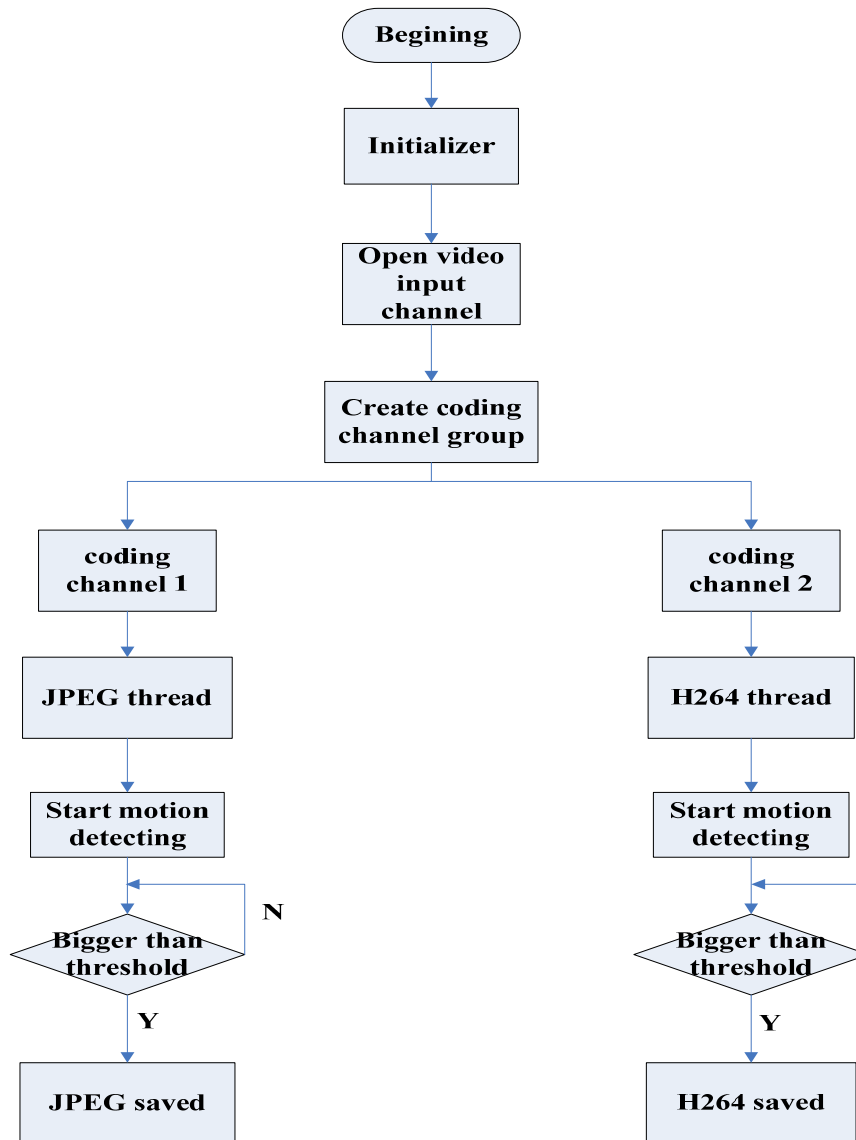

Figure 5. The Function of Software Processes

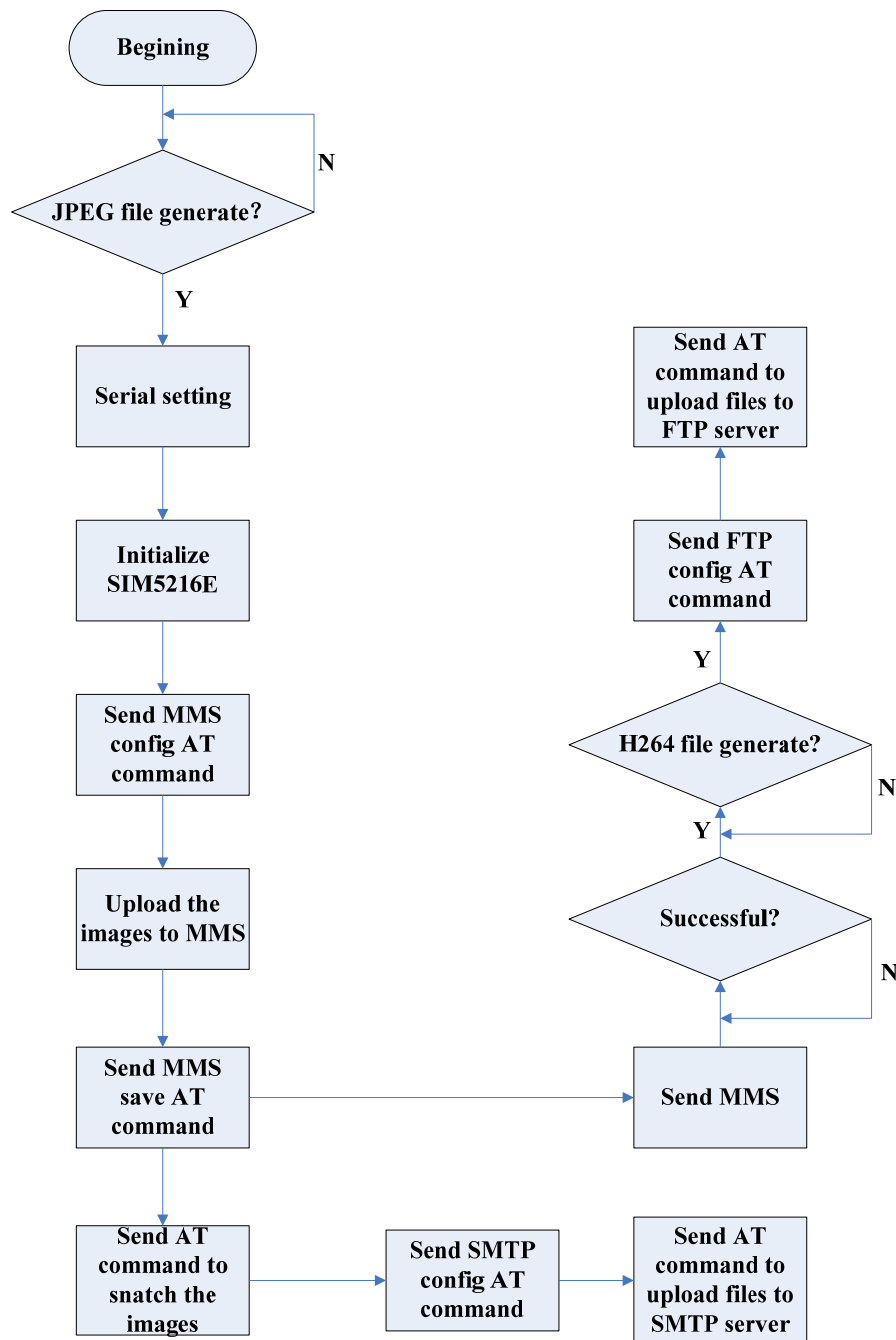

Figure 6. Send the Abnormal Video Data

#### 4.5. The Software of User Request Data

If having not received alarm image from the front-end for a long time, the user can according to his requirement control the-front to send video data to his mobile phone. The user needs to send a special SMS to the front-end, and the video surveillance front-end will send the corresponding video data to the mobile phone of the user by analysing the content of the SMS. Hi3515 will regularly send the AT command to SIM5216E to read the SMS. If having read the SMS sent by the user, Hi3515 will execute the corresponding program. Function of the software program flow is shown in Figure 7.



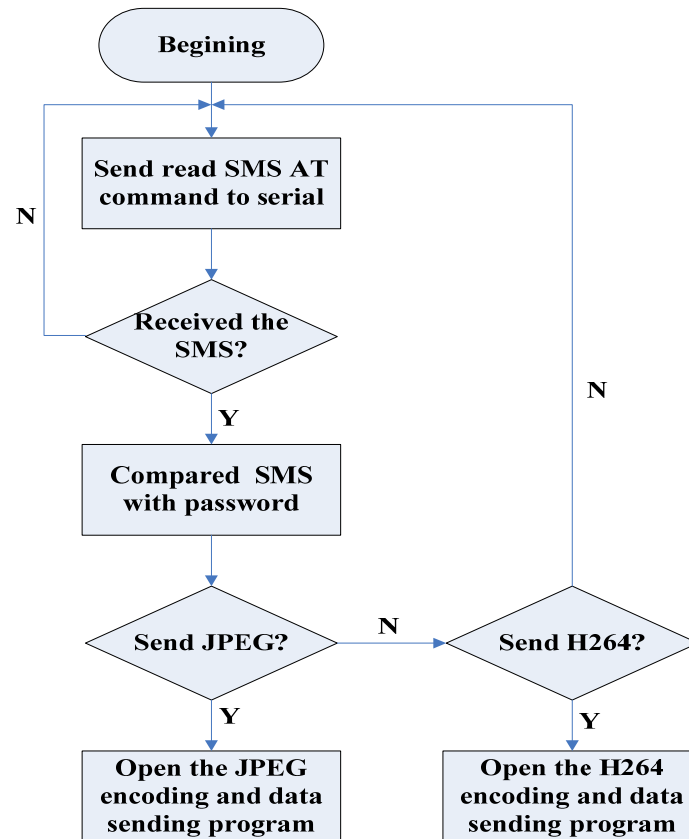

Figure 7. User Request Data

### 5. System Control Software

Through the system control software, the surveillance front-end can selectively send video data, reducing the use cost; At the same time it completes the man-machine interaction function and improves the flexibility of usage of the system. System control software includes four parts: Abnormal events control, mobile phone control, surveillance center control and regularly send control. When abnormal events occur, the surveillance front-end will send an alarm image to users by MMS, and upload video data to the SMTP/FTP servers synchronously; The front-end will continually check whether it has received the control SMS from the user and choose to send the images or video clips of surveillance scenario according to the content of the SMS; Equipped with the specific visualization software, PC surveillance center can realize controlling the monitoring front-end by operating this software, such as choosing transmission of video data or setting the video acquisition parameters of the surveillance front-end; When there is no abnormal event and the control commands are not received, the surveillance front-end will also regularly send the images of surveillance scenario to the user's phone by MMS, and the time parameter is set in advance.

System control software program flow is shown in Figure 8.

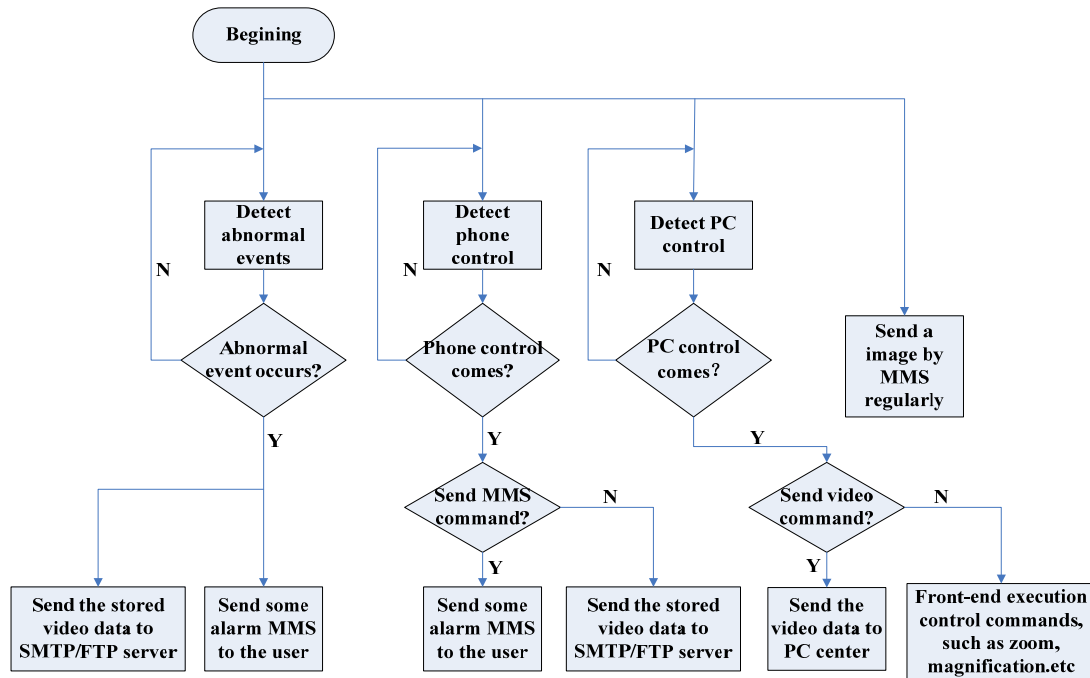

Figure 8. System Control Software

## 6. Conclusions

In WCDMA network environment, test the function of receiving the video data for mobile phone, email and FTP server. By the test, receiving image by mobile phone, receiving images by email box and receiving video clips by FTP server meet the expected design requirements. Test results are shown in Figure 9, 10, 11.

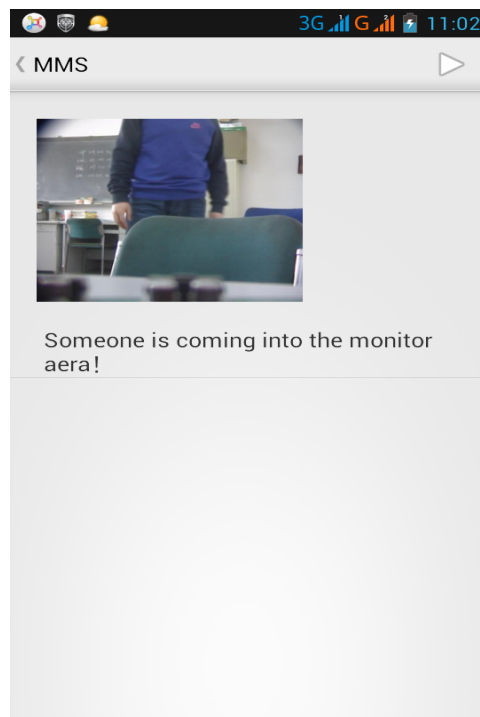

Figure 9. Mobile Phone Receiving Testing

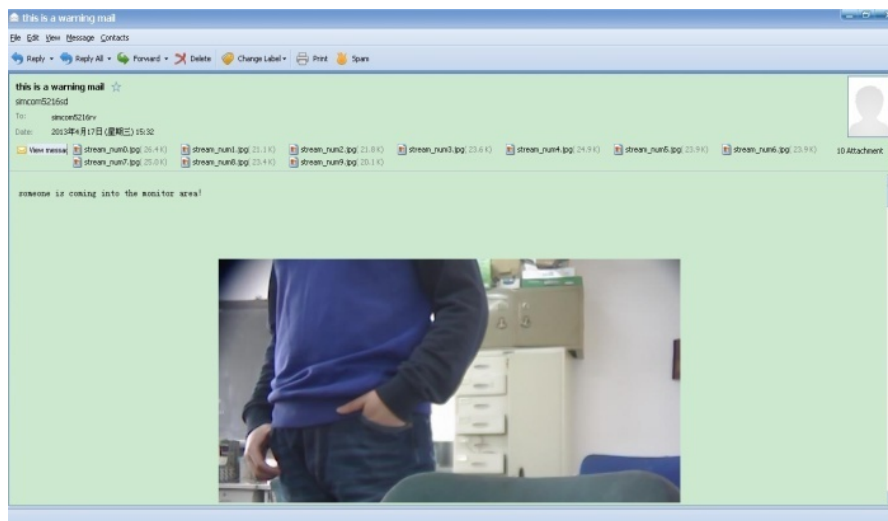

Figure 10. Mail Receiving Test

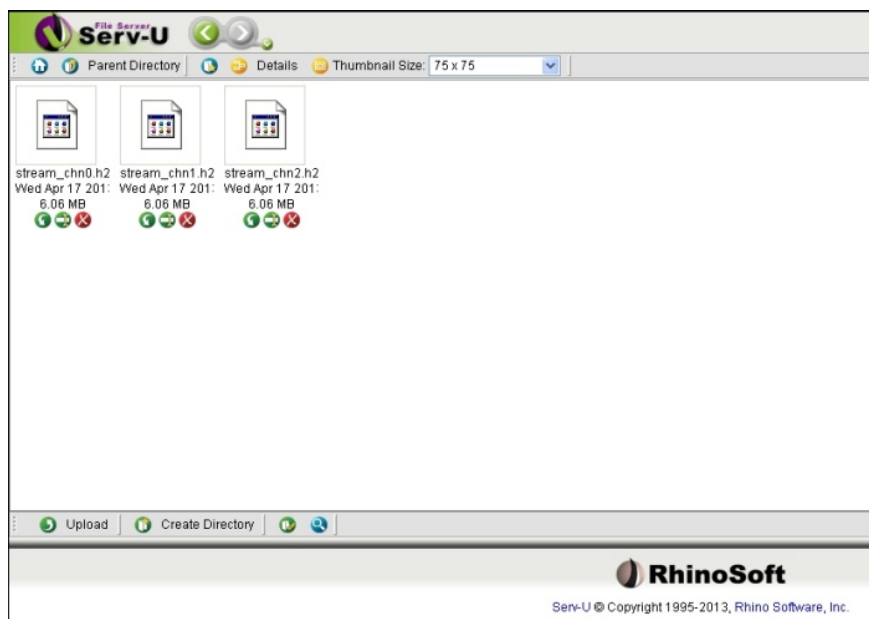

Figure 11. FTP Server Receiving Test

This paper has designed an intelligent video surveillance system based on the 3G mobile network and embedded technology, studied the intelligent analysis and control of the system, and realized transferring the video data by the 3G network. The system can provide a better remote video surveillance service, convenient and flexible for application and of low cost for construction. Cooperated with the functions of intelligent video analysis and transmission control, it has solved the problem of the high costs produced during transmission using 3G networks and improved the flexibility of the system application. Meanwhile, it has been proved by practice that the combination of Hi3515+SIM5216E reduces the difficulty of developing a surveillance system, shortens the development cycle and is an ideal and highly stable surveillance solution. With the popularity of 3G network, combining with the corresponding intelligent video analysis algorithms and control program, this system can be widely used in

warehouse surveillance, forest fire protection, bank surveillance, railways surveillance and so forth. Users can obtain the surveillance data by mobile phone, very convenient and efficient.

### Acknowledgments

This work was supported in part by a grant from funded project:9002-03010173.

### References

- [1] Zhu Haihua, Chen Zigang. The Design of Wireless Video Home Security System Based on the 3G. *Computer Measurement & Control*. 2011; 19(12): 2982-2984.
- [2] Li Feipeng. 3G Mobile Communication technology and Its Application. *Information and Communication*. 2011; 4: 70-71.
- [3] Lin Mei, Longhu Chen, Zhiwei Tang. 3G Intelligent Video Analysis System of Vehicle on DM6446. *TELKOMNIKA Indonesian Journal of Electrical Engineering*. 2013; 11(5): 2475-2484.
- [4] Li Weishu. *The Design of Wireless Video Surveillance System Based on the 3G Network*. Tianjin: Tianjin University. 2011: 5-7.
- [5] Lou Mengzhao. *The Design of Video monitor Based on ARM9 and WCDMA*. Qinhuangdao: Yanshan University. 2012: 9 -15.
- [6] ANDERSSON C. *GPRS and 3G wireless applications*. [S.1.]: John Wiley & Sons, Inc. 2001: 30-60.
- [7] Shanghai SIMCom Wireless Solutions Ltd. *SIM5215E & SIM5216E\_HD\_V1.01*. Shanghai: SIMCom Wireless Solutions Ltd. 2010.
- [8] Shanghai SIMCom Wireless Solutions Ltd. *SIM521x\_EVB\_User Guide\_V1.01*. Shanghai: SIMCom Wireless Solutions Ltd. 2011.
- [9] Shenzhen HiSilicon Ltd. *Hi352/Hi3515 The Development Reference of Media Processing Software*. Shenzhen: Shenzhen HiSilicon Ltd. ,2010
- [10] Wen Shang Shu, Chen Gang, Feng Limei. *Learn Embedded Linux Application Development from Practice*. Beijing: Electronic Industry Press. 2012: 9-32.
- [11] Peilong Xu. Study on Moving Objects by Video Monitoring System of Recognition and Tracing Scheme. *TELKOMNIKA Indonesian Journal of Electrical Engineering*. 2013; 11(9): 2-11.