

Investigation of partial discharges in non-woody kenaf based pressboard under influence of moisture

Rizda Fitri Kurnia^{1,2}, Norhafezaidi Mat Saman¹, Mohd Hafizi Ahmad¹, Zainuddin Nawawi²,
Nur Azalia Azrin¹, Mohd Aizam Talib³

¹Institute of High Voltage and High Current (IVAT), Universiti Teknologi Malaysia, Johor Bahru, Malaysia

²Department of Electrical Engineering, Faculty of Engineering, Sriwijaya University, Ogan Ilir, Indonesia

³Tenaga Nasional Berhad Research, No. 1, Kawasan Institusi Penyelidikan, Kajang, Selangor, Malaysia

Article Info

Article history:

Received Aug 15, 2022

Revised Sep 19, 2022

Accepted Sep 25, 2022

Keywords:

Kenaf-polypropylene
pressboard

Moisture

Normal pressboard

Partial discharge

Scanning electron microscopy

ABSTRACT

The most crucial parts that decide the transformer's lifetime are the solid insulation of the power transformer, especially the pressboard and kraft paper. The life of the insulation is significantly influenced by the presence of water in the insulation. This paper presents a study on partial discharge (PD) on the existing normal pressboard (NP) and the newly developed Kenaf-polypropylene pressboard (KPP). Also, the moisture content of the pressboard varied between 0%, 1%, and 3% by the percentage weight of different methods. After the initiation of PD, the surface deterioration analysis was performed by using scanning electron microscopy (SEM). The results from the study revealed that KPP shows superior performance in mitigating PD. At 0%, 1% and 3% moisture contents, KPP showed 89%, 83% and 25% reductions in average PD magnitude, respectively. Overall, the kenaf composite pressboard has better PD resistance, which is one of the things to think about when insulating a transformer.

This is an open access article under the [CC BY-SA](https://creativecommons.org/licenses/by-sa/4.0/) license.



Corresponding Author:

Mohd Hafizi Ahmad

Institute of High Voltage and High Current (IVAT), Universiti Teknologi Malaysia

81310 Johor Bahru, Johor, Malaysia

Email: mohdhafizi@utm.my

1. INTRODUCTION

The electrical supply system is recognized to require a power transformer as critical hardware. A power transformer's unexpected breakdown might lead to a number of issues that would immediately impact the electrical supply system. For instance, a straightforward malfunction at the distribution end will result in an electrical blackout in the contained area. Additionally, a long-term interruption in transformer operation due to a failure of the insulation results in a loss of revenue, which is the main concern of asset managers for utilities. Since the oil in transformers is in direct contact with high voltage (HV) components, the failure of the transformer could be extremely harmful. Hence, a transformer failure could make a fire more likely. Therefore, it is critical to check on the health of the insulation materials, such as pressboard, paper, and insulating oil. The oil-filled transformer's insulation system is made up of organic materials, primarily hydrocarbon oil and cellulose insulation. The insulating oil serves primarily as a heat transmission fluid [1]. The cellulose insulation, which includes a pressboard and paper, provides mechanical support and separates the transformer winding. Among the transformer insulation parts, cellulose is regarded as the most important insulating substance because it determines the transformer's lifetime [2]-[4]. However, as the transformer's lifespan lengthens, the insulation deteriorates and its chemical composition changes.

Recent years have seen a rise in interest in the research of kenaf (*Hibiscus Cannabinus L.*) as a source of manufacturing materials, particularly in the biocomposite sector. Kenaf is chosen as a substitute

material because of its quick growth and benefits of non-woody plants. In addition, kenaf is a plant with a high rate of photosynthesis, making it an environmentally friendly, sustainable, and renewable source of fiber for different types of paper. Kenaf is identified as an alternative source of fibrous materials for the 21st century. Additionally, the United States development agriculture recognizes kenaf as the non-wood commodity with the greatest potential for paper production (USDA). The water-resistant insulation was made to withstand exposure to water without suffering significant physical damage [5]. Zawawi *et al.* [5] developed a paper with great water resistance, that using kenaf fiber combined with synthetic polyethylene (PE). Besides, Zukowski *et al.* [6], discovered that mixing cellulose with its derivatives, such polyamide, produces good water resistant properties.

By decreasing its electrical and mechanical qualities, moisture in the transformer causes the insulation to degrade. A known cause of partial discharge activity and other dangers that interfere with the transformer's operation is excessive moisture. The current cellulose pressboard has strong dielectric properties, but its key downside is hygroscopic behaviour. Generally, the moisture inside the pressboard could introduce specific threats such as ignition of partial discharge, emission of gaseous bubbles at high temperatures, and acceleration of cellulose paper ageing [7], [8]. PD charge magnitude (q), partial discharge inception voltage (PDIV), and breakdown voltage (BDV) are the variables that are used to determine the integrity of oil-impregnated pressboard (OIP). The presence of PD activity is an alarming indicator of the developing of a dangerous defect, resulting in the transformer's failure. The factors initiating PD activities are electrical or mechanical weakening in voids, delamination, gas bubbles or conductive particles, and excessive moisture [7], [9]. Table 1 defines the condition of solid insulation with moisture content, as stated in IEEE ® Std 62 - 1995 [10].

Table 1. Moisture content condition of solid insulation [10]

Type of insulation	Moisture (%)
Dry insulation	0-2 %
Wet insulation	2-4 %
Very wet insulation	> 4.5 %

Numerous research have focused on how moisture and temperature affect insulation because they accelerate the deterioration process. Rahman [11] investigated the effect of moisture on the PD characteristics of oil-impregnated pressboards. Meanwhile, Zhang *et al.* [12] and Khawaja and Blackburn [13] both explored the effect of temperature on PD behaviour. According to their findings, PD activity has significantly increased as a result of the rise in temperature or moisture content of cellulose insulation. Because cellulose insulation is hygroscopic, some risks, such the ignition of PD, could arise when the transformer is in use. In addition to hygroscopic problems, another drawback of the current pressboard is that it is made from wood pulp. In order to produce an insulating pressboard with great mechanical strength, long-fiber softwood is preferred [14]. As a result of growing environment friendly products, numerous types of study have been done to look for substitute resources to replace the wood-based sector as a method to get ready for a global lack of forestry resources. Several plants that don't make the wood have been found. Most of them come from fast-growing species, like Acacia mangium, Shorea macrophylla, kenaf, bamboo, and a few others [15].

The kenaf crop, one of the non-wood species described, has exceptional potential for producing paper and pressboard. due to the qualities of its fibers, especially the outer part, which are affordable, low density, tough, recyclable, have adequate strength capabilities, and are biodegradable [15]. Besides, the chemical compositions of kenaf, especially the core, are almost like wood in behavior. Kenaf has been studied for use in a variety of industries, including agriculture, transportation, furniture, and building construction. The kenaf investigation has not been carried out in great detail in electrical insulating locations. Although kenaf has the potential to replace the current cellulose transformer insulation, pressboard in particular has not yet been the subject of any research. Hitherto, only Chen *et al.* [16] explored the heat aging characteristics of kenaf bast fiber as electrical insulating paper. They discovered that kenaf bast fibers have excellent anti-aging characteristics. [16]. However, the study's main objective was kenaf paper, and the only variable considered was temperature.

For these reasons, a newly developed kenaf pressboard was proposed as an alternative to the current wood-based pressboard [17]. While kenaf research is still in its early stages, the government offers numerous incentives to promote kenaf use [18]. There has not yet been a thorough investigation on the use of kenaf as insulation for transformer pressboard. Therefore, the objective of this article is to study the newly developed kenaf composite pressboard KPP focusing on its characteristics towards PD activities and a comparison with the existing pressboard NP. Also, their hygroscopic behaviour towards changes moisture levels. Besides that, the impact of PD activity on surface deterioration was observed between normal pressboard (NP) and Kenaf-

polypropylene pressboard (KPP) pressboard at a different moisture content. This study is important since it will provide information about the newly created kenaf composite pressboard that was made. It has been hypothesized that KPP research will improve the water resistance of cellulose insulation. Besides, KPP has resulted in a better insulation performance compared to the existing NP although under high moisture conditions. Kenaf composite pressboard shows the superior performance of mitigating the PD thereby reducing risks of failures.

2. MATERIALS AND METHODS

2.1. Preparation of the Kenaf Pressboard

The kenaf core and stem were separated using a decorticator. The pulverizer was then used to reduce the size of the core after it had been put into a flake. Only kenaf with a diameter between 0.5 and 0.25 m was chosen from the kenaf core's screening. After that, to remove moisture, the kenaf fiber and polypropylene were dried in a vacuum oven for 24 hours at 80 °C. After that, the polypropylene and kenaf composites were mixed together in a twin-screw mixer at 175 °C and 300 rpm. The polypropylene and kenaf composite was placed into a mould when the compounding process was finished. The blended composite was first compressed for nine minutes at 175 °C while being allowed to cool for around three minutes. The sample was prepared for testing by conditioning it for 24 hours at 23 °C room temperature.

2.2. Kenaf pressboard moisture addition

To simulate dry and wet insulation, respectively, samples with moisture contents of 0%, 1%, and 3% were employed in this study. The pressboard was first dried for 24 hours at 105 °C and 100 Pa of vacuum to get rid of any moisture that may have been present. The pressboard sample was kept in Memmert's Humidity Chamber to raise the moisture content. The pressboard samples were then impregnated by being submerged in mineral oil for 24 hours under vacuum. Different weight percentage techniques developed in (1) were used to determine the percentage of water absorbed by the pressboard [19], [20].

$$\% M_i = \frac{W_{wet} - W_{dry}}{W_{dry}} \times 100\% \tag{1}$$

where % M_i is the percentage of water absorbed, and W_{dry} is the weight of the dried pressboard before placing it in Memmert's Humidity Chamber. Whereas W_{wet} is the weight of moisturized pressboard exposed to moisture.

2.3. Test cell configuration for partial discharge measurement

The CIGRE method II configuration served as the foundation for the experimental model for PD measurement in this work [21]–[23]. For the purpose of characterizing the PD activity of the void at oil-paper interfaces, the test cell was constructed. The pressboard samples consist of three layers attached to form a sandwich structure of insulation paper. The top and bottom layers are 3.0 mm thick pressboard each. Meanwhile, the middle-layered paper functions as a spacer with a 0.5 mm thickness. An artificial disc-shaped void with a diameter of 1.0 mm was created. The structure of the test cell used in this study is shown in Figure 1. To avoid surface flashover, mineral oil was poured into the test cell.

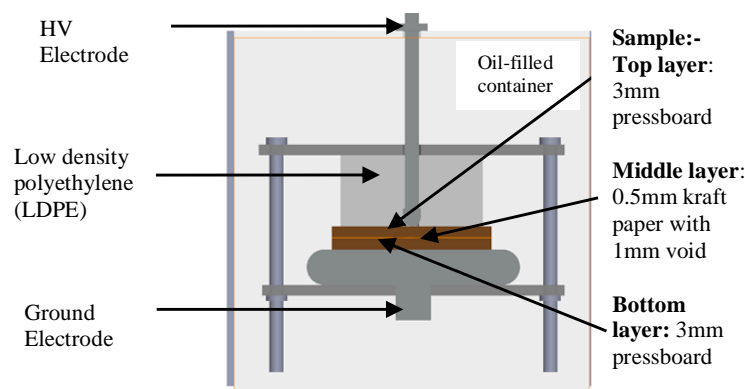

Figure 1. CIGRE method II test cell configuration

2.4. Partial discharge measurement setup

The PD of oil-impregnated pressboard was measured using an applied voltage that was 1.6 times the PDIV. After that, a constant AC voltage was maintained for 6 hours for the experiment, depending on the recurrence of discharges [24]. By using Haefely's PD calibrator type 451, the PD apparent charge was calibrated prior to the measurement. Figures 2 and 3 show the equivalent circuit diagram and how the PD is set up.

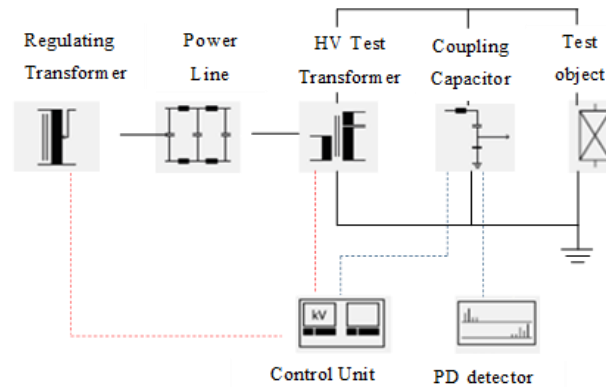

Figure 2. Schematic diagram of partial discharge setup



Figure 3. Haefely's partial discharge measurement setup

3. RESULTS AND DISCUSSION

PD magnitude and PDIV, especially in the case of oil-impregnated pressboard, are typically the key factors that define the integrity of the insulation [11]. Also, PD characteristic is one of the essential factors in diagnosing insulating materials [23]. In this section, PDIV, PRPD pattern, Statistical Moments for PD magnitude, and SEM analysis were analyzed accordingly.

3.1. Partial discharge inception voltage (PDIV)

When there is one or more PD pulses arose initially, the PDIV was determined. The voltage across the sample was steadily raised until the discharge pulse appeared in order to measure PDIV. The PDIV for NP and KPP is shown in Figure 4 under various moisture conditions. NP0, NP1 and NP3 represent the NP with 0%, 1%, and 3% moisture, respectively. Similarly, for KPP also KPP0, KPP1 and KPP3. The PDIV value drops as pressboard's moisture content rises, as is shown in Figure 4's distinct trend. The maximum PDIV value is displayed by dry pressboards with zero moisture. The highest PDIV is displayed by the KPP0 at 6 kV, followed by the NP0 at 4.18 kV. At 1% moisture content, the maximum PD magnitude of KPP1 was 39% lower than NP1.

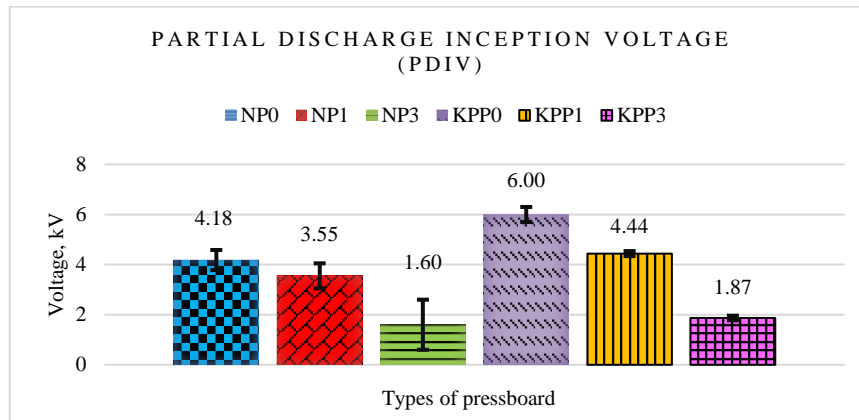

Figure 4. PDIV for NPs and KPPs at different moisture conditions

The smallest number of PDIV occurred at 3% moisture level, when the first pulses were presented by NP3 at 1.6 kV and by KPP3 at 1.87 kV. On an average of three moisture conditions, KPP recorded PDIV is more than 25% increment than NP. Also, the applied voltage for pressboards with 3% moisture content was decreased by 72% and 60% for KPP3 and NP3, respectively. Because water molecules in poly-molecular layers require less ionizing energy on wet pressboards than on dry pressboards, the considerable decline in PDIV on wet pressboards can be explained [25]. The PDIV on dry pressboard was higher because the water molecule ionization's contribution to the discharge's initiation was minimal [26].

3.2. Phase resolved partial discharge (PRPD) pattern

According to each sample's PDIV, a different applied voltage was applied. Figure 5 presents the PRPD pattern of each sample after conducting a PD experiment for 6 hours. Figures 5(a) to (f) make it clearly visible that the high voltage stress that caused the majority of the discharge pulses to be generated by all samples was concentrated towards the peaks of both half cycles. The symmetrical pulse patterns suggest that internal void discharge is what caused the PDs.

Based on PRPD patterns of dry and wet condition pressboards, as shown in Figure 5, the maximum PD magnitude of NP at 0%, 1% and 3% are 181 pC, 425 pC and 1620 pC, respectively. Similarly, for KPP, 38 pC, 110 pC and 810 pC are shown. The comparison between NP and KPP indicates that the KPP maximum PD magnitude is 4.76, 3.86, and 2 times lower than NPP for 0%, 1%, and 3 % of moisture. Besides that, it was found that lesser PD pulses appear for KPP samples. Interestingly, even though the applied voltage was higher for KPP, the PD magnitude was significantly lower than the NP.

As a consequence of PD trends, as the moisture level rises, the PD magnitude also rises. Not only for NP, but KPP also shows the same trend. These outcomes were connected to Rahman *et al.* [11] work, they discovered that the PD magnitude of the pressboard gained with the increasing moisture content. Besides, when moisture levels increase, the phase range becomes wider in terms of PD phase occurrences.

Between both types of pressboards, KPP demonstrates greater resistance to PD occurrences compared to NP. In addition, KPP was able to tolerate a higher voltage with lesser PD occurrence. This can be elucidated probably due to the combination of KPP and resin (polypropylene), thus mitigating water absorption properties. The chemical component in the resin can be cross-linked with hydroxyl groups in kenaf fibres, which reduces the hygroscopicity of the pressboards [27].

Compared to NP, KPP has excellent electrical characteristics that prevent the formation of PD. According to Table 2, the average PD magnitude for KPP at 0%, 1%, and 3% of moisture levels, respectively, was 89%, 84%, and 25% lower than NP. It might be because kenaf has low porosity, which makes PD less likely to form because there are less internal voids [28]. The results are consistent with those of Batouli *et al.* [29] and Yusoff *et al.* [30], who found that increased kenaf loading led to less porous composites, which offered higher shear resistance. Additionally, mixing polypropylene with kenaf could result in materials with improved PD resistance properties. This investigation was related to Fujita *et al.* [31] study, which discovered that the combination of cellulose and polypropylene provided excellent electrical, mechanical, oil-resistant, and oil-impregnate-able qualities and was well-suited for the insulation of high- and extra-high voltage oil-filled electric power appliances. Additionally, researchers discovered that cellulose and polypropylene combined produced a material with superior qualities than pressboard or common paper for commercial purpose, including good resistance to dielectric stress, low dielectric loss, high thermal resistance, and low permittivity [2].

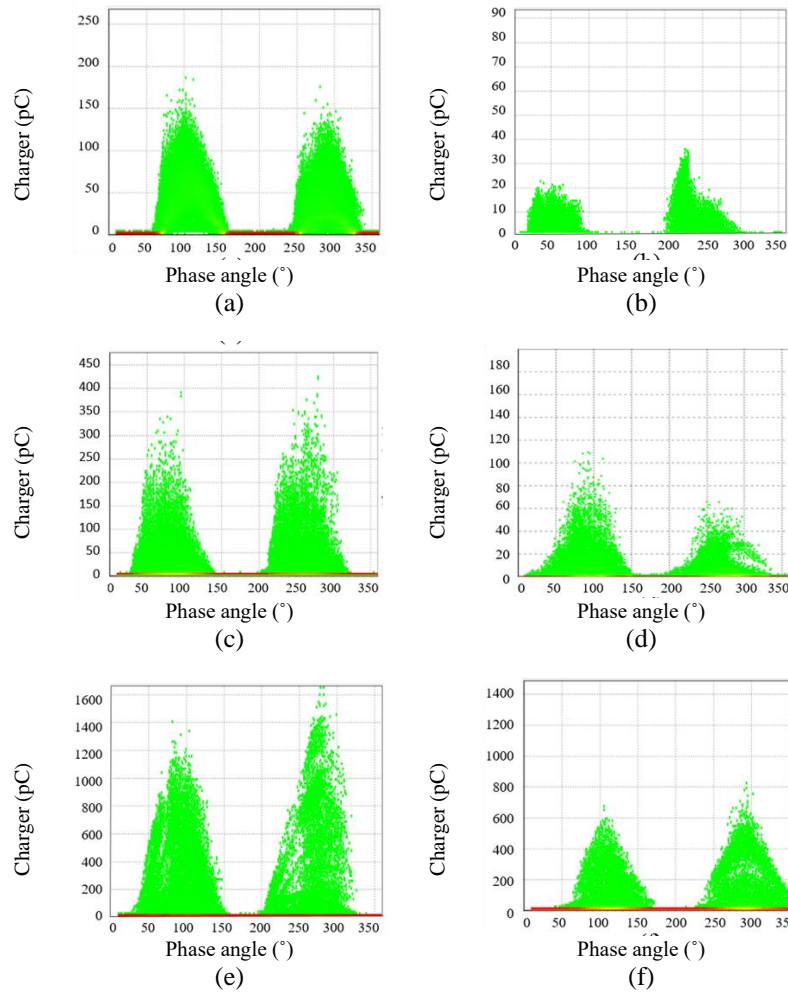

Figure 5. PRPD patterns after six-hour PD measurement (a) NP0, (b) KPP0, (c) NP1, (d) KPP1, (e) NP3, and (f) KPP3

In furthermore, it was discovered that for both NP and KPP, PD magnitude increased with growing wetness. According to Table 2, when moisture increased from 0% to 1%, the PD magnitudes of NP and KPP somewhat increased. Average discharge for NP and KPP increased by no more than 15 pC once the moisture level increased from 0% to 1%. However, average discharges for NP and KPP increased dramatically to over 78% at 3% of the moisture level. According to IEEE® Std. 62 - 1995's interpretation criteria for percentage of moisture by dry weight of paper, this anomaly could be explained [32]. According to the above-listed standard IEEE® Std 62, the pressboard was considered dry with 0 to 2% moisture.

Table 2. Summary of partial discharge data

Sample	PD characteristics	Moisture content (0%)			Moisture content (1%)			Moisture content (3%)		
		Min	Max	Ave	Min	Max	Ave	Min	Max	Ave
NP	Discharge magnitude (pC)	95.5	326.2	236.9	86.8	539.0	249.1	612.8	1630.4	1166.5
	Phase occurrence of positive PDs (°)	30	140	-	60	160	-	30	150	-
	Phase occurrence of negative PDs (°)	200	320	-	240	340	-	200	300	-
KPP	Discharge magnitude (pC)	4.0	48.8	25.5	16.3	110.0	40.2	115.2	1120	871.7
	Phase occurrence of positive PDs (°)	20	90	-	10	150	-	60	170	-
	Phase occurrence of negative PDs (°)	200	300	-	190	330	-	225	300	-

However, when moisture levels were between 2 and 4%, wet insulation was detected, and when moisture levels exceeded 4.5%, extremely wet insulation was determined. Because both of these pressboards fell into the same category, there were no significant variations between 0% and 1% moisture in this instance (dry). As a result of the 3% pressboard being in the wet category, where a lot of moisture accelerated cellulose degradation, a considerable PD rise was seen.

3.3. Statistical analysis of partial discharge magnitude

To evaluate PD test results and define the magnitude distributions over the course of the test's six hours, a statistical approach was used. In this analysis, the mean, standard deviation, skewness, and kurtosis for each distribution were used to evaluate the PD magnitude. The dispersion and form of the PD distribution are indicated by the skewness and kurtosis. Greater PD magnitudes are indicated by positive skewness at lower phase angles and higher PD magnitudes by negative skewness at higher phase angles. Kurtosis will also reveal details about the PD data's shape properties. When the kurtosis is larger than 3 ($Ku > 3$), the PD magnitude distributions are said to be sharpened, but when it is less than 3 ($Ku < 3$), the distribution is said to be flattened.

Figure 6 displays the statistical moments of PD data collected for all samples over a period of six hours of testing. Figures 6(a) to (d) show the mean, standard deviation, skewness, and kurtosis of the PD magnitude during a period of six hours, respectively. Over the course of six hours of measurements, the mean for NP0 steadily rises from 100 pC to 350 pC. In the third hour, the burst PD was observed and the KPP0 varied. The sudden changes in PD magnitudes are known as bursts, and they happened during PD distribution fluctuations, indicating that activity of space charge increased during rapid increasing in PD occurrences [33]. The PD magnitude gradually dropped following the PD burst until the experiment's completion. The average PD magnitude ranged between 4 and 50 pC.

For the first three hours, the mean PD magnitude of NP1 rapidly elevated. This outcome is in line with that of Niasar *et al.* [34], discovered that huge discharge pulses first developed just after electrical stress. This may have happened because there were initial free electrons available inside the cavity, which triggered discharge to occur across the cavity, raising the magnitudes of PD [34]. After the third hour, the PD magnitude then rapidly dropped to 100 pC. It was noted that the PD burst in the case of KPP1 happened within the first 25 minutes. When dramatic variations in PD magnitudes had place, PD bursts were seen. This demonstrated that the activity of space charge rose during the PD events' bursts [35]. Before stabilizing at 40 pC, the mean PD magnitudes varied during the first 100 minutes.

In the case of NP3, the mean value displays a notable rise in PD magnitude, however the value decreased during the final hour. This was most likely caused by the residual ions and PD byproducts, which shielded the empty surface by covering it. The voltage across the void then dropped, which reduced the intensity of the discharge [34]. The PD magnitude was between 600 pC and 1500 pC. Finally, for KPP3, there was a gradual increase in PD magnitude with minor fluctuations. After 100 minutes of measurement, the PD magnitudes remained between 800 pC and 1000 pC until the end of the experiment.

Figure 6(b) describes the standard deviation for NP0, KPP0 and KPP1. Minor fluctuations happen in the first two hours of the experiment, followed by no changes. The NP1 standard deviation fluctuated recognizably for the early 3 hours, then reduced to a minimum for the later part of the experiment. The NP and KPP at 3% moisture show significant changes in the standard deviation for the rest of the experiment.

The skewness and kurtosis, meanwhile, varied steadily throughout time. According to Figures 6(c) and (d), the majority of PDs data were skewed to the right due to NP0, showing the greater PD magnitude at a lower phase angle. While this is going on, the measurement defining the PD magnitude distribution has a flattened peak, which causes the kurtosis to behave more negatively ($Ku < 3$). The skewness and kurtosis variances are consistent with the finding of Ahmad *et al.* [33]. On the other hand, KPP0's skewness and kurtosis varied with time. Since most of the PD's data have more than zero skewness, the skewness has a greater negative impact. The kurtosis, meanwhile, demonstrates that $Ku < 3$ causes the majority of the data to spread flatly. Positive kurtosis ($Ku > 3$) shows that the PD magnitude had a more flattened distribution, while the skewness features of NP1 demonstrate that the distribution of PD magnitude was primarily tilted toward to the right (>0). Most PD magnitude distributions for KPP1 have kurtosis smaller than 3 ($Ku < 3$), with both positive and negative skewness and kurtosis being present. Thus, the flattened distribution may be seen in the PD magnitude.

For NP3, the skewness and kurtosis display both positive and negative distributions. The majority of PDs data show negative skewness (0) and kurtosis ($Ku < 3$), according to the distribution patterns. Last but not least, KPP3's skewness and kurtosis demonstrate conflicting PD data in which both statistical parameters are likely to have a negative distribution.

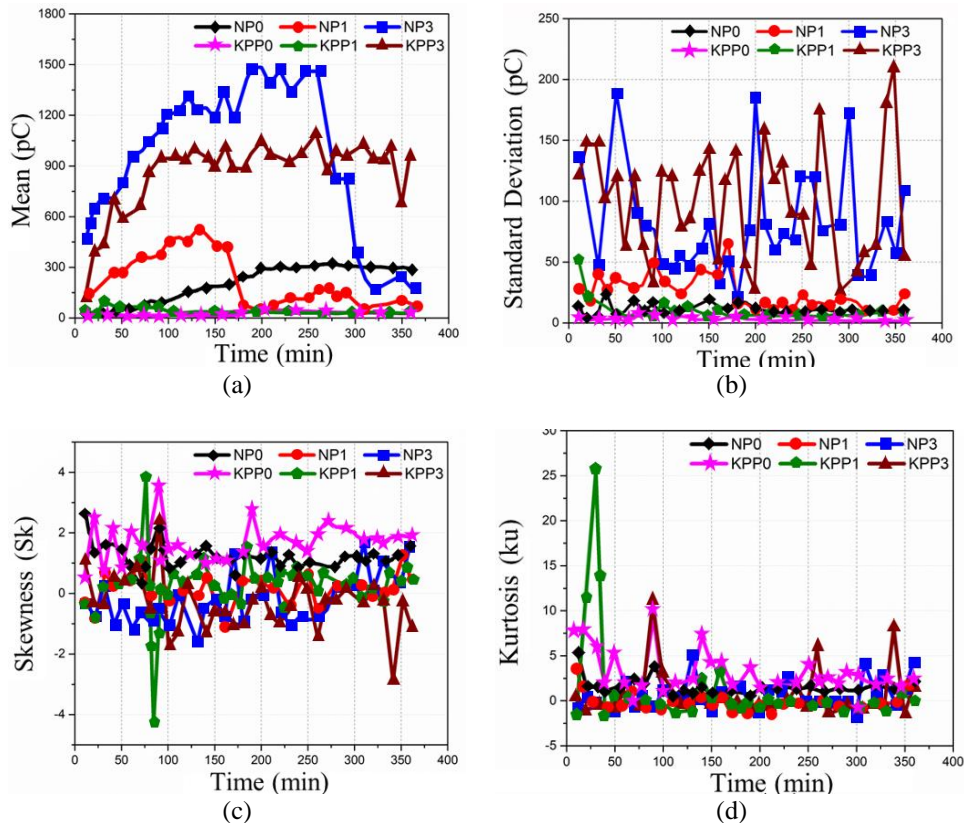

Figure 6. PD data collected for all samples over a period of six hours of testing (a) Mean, (b) standard deviation, (c) skewness, and (d) kurtosis of partial discharge magnitude for all samples

3.4. Scanning electron microscopy (SEM) Analysis

The fibre morphological analysis was done by conducting SEM analysis on the surface and cross-sectional area of pressboards. When a sample is exposed to an intensely concentrated electron stream from an electron gun, high-energy electrons that are liberated from the sample's surface are detected by SEM. This electron beam is focused to a small area on the sample surface using the SEM objective lens.

3.4.1. Surface morphology

The surface morphology of dried NP and KPP before and after PD testing is shown in Figures 7 and 8. Over the course of six hours, pressboards were subjected to varying voltage stresses for PD characterisation. Figures 7 and 8 demonstrate how completely different the surface structures that NP and KPP presented were. It was discovered that KPP has a smooth, flat, and non-fibrous surface structure whereas NP has a structure of tightly packed cellulose fibers.

Figure 7(a) shows a densely woven network of cellulose fibers for NP0 that is devoid of any deformation components. Even though the cellulose fibers' links were made more tightly, there were still a few microscopic gaps between the links. Despite this, two elements—surface roughness and fiber diameter—were seen to change after PD events. After PD events in Figure 7(b), it was seen that the surface of the fibers had grown rougher and more deformed. Additionally, some fibers' irregularly sized fibers were cleaved by the impact of PD. These outcomes agreed with those of Zhang *et al.* [12], who discovered that the thermally aged paper had a rougher surface, a shorter length, a smaller thickness, a more sparse structure, and wider gaps between fibers.

However, for KPP0, in Figure 8(a) no fibers were visible on the kenaf pressboard's surface because they were buried inside the pressboard. Figure 8(b) demonstrates that a small flaw (micro size) developed on the surface of the kenaf pressboard following PD measurement. On several areas of the surface of the kenaf pressboard, PD activity left an irregular black coloring. A cross-section SEM was performed in a different section since the KPP revealed no fiber structure.

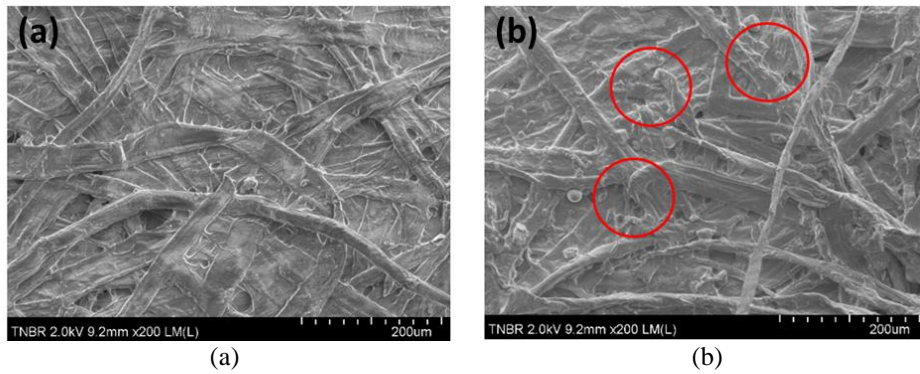

Figure 7. Surface morphology of NP0 (a) before partial discharge measurement and (b) after partial discharge measurements

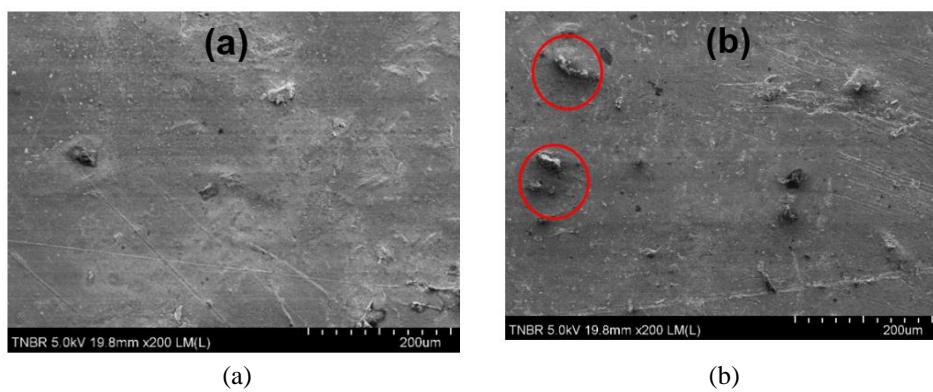

Figure 8. Surface morphology of KPP0 (a) before partial discharge measurements and (b) after partial discharge measurements

3.4.2. Cross-section morphology

Figure 9 shows the KPP0 cross-sectional structure. Figures 9(a)-(b) it was made very obvious that kenaf fiber has a larger diameter and a shorter length than NP0, this fiber property was mentioned in the study by Saleh *et al.* [36]. The inside part of the kenaf fiber did not show any notable alterations. The void discharge's hits lack the energy to sever the fibers of kenaf.

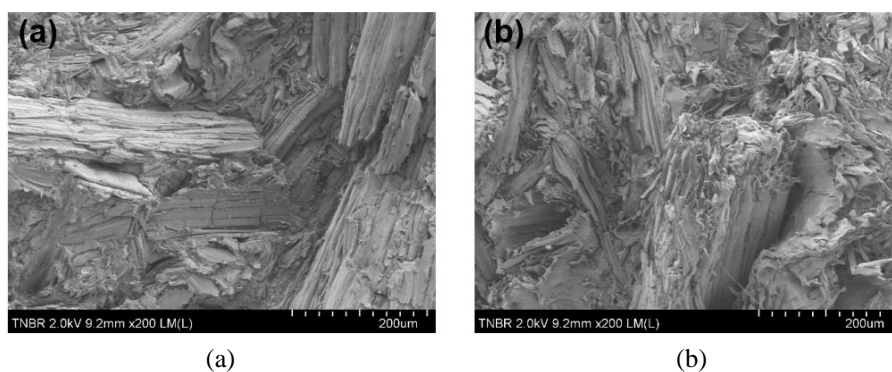

Figure 9. Cross-section view of KPP0 (a) before partial discharge measurements and (b) after partial discharge measurements

In conclusion, it was found that KPP has a non-fibrous surface morphology while NP has a densely packed surface structure. A cross-section picture of KPP reveals its fiber structure. Additionally, it was noted

that KPP had a structure with a bigger diameter and short fibers. Following the onset of PD, the diameter and roughness of the NP surface fiber changed significantly. The tested pressboard was a fresh sample that had not gone through any heat aging, therefore the NP structural changes were minimal.

In contrast, the surface of the KPP was found to have an irregular black color. No significant changes have occurred based on the internal fibre structure. Thus, it can be interpreted that both types of pressboards undergo surface degradation due to the impact of PD, which did not entirely occur in the internal part.

3.4.3. Surface deterioration

Using an optical microscope (Olympus BX60) with a 200x magnification, the surface degeneration of pressboards was examined after six hours of PD operation. Figure 10 dealt with the photographs of sample deterioration. Figures 10(a) and (b) show, for NP0 and KPP0, respectively, the surface deterioration image effect of PD activities. A little black area was drawn in Figure 10(a) at the center of the NP0 surface, just next to the spherical HV electrode. A strong electric field converging at the pressboard's center during PD measurement increased the PD activities. Figure 10 depicts the surface of KPP0 where a micro flaw was found (b).

Figures 10(c) and (d) show, for NP1 and KPP1, respectively, the effects of surface deterioration photos of PD activities at 1% moisture content. The carbonized traces on the surface of NP1 in Figure 10(c) have steadily risen as compared to NP0. Figure 10(d) for KPP1 clearly shows a dented area in the middle of KPP1, which is where the HV electrode was attached. Due to repeated PD operations, Cheng *et al.* [37] found that the high voltage electrode was close to the severe carbonization point.

Figures 10(e) and (f) respectively exhibit the surface deterioration images for NP and KPP at 3% moisture content. Both NP and KPP display nearly that very same images of degeneration at 3% level of moisture condition. One condition that increases partial discharge activity and, as a result, erodes the insulation and creates carbon traces, or carbon tracks, is moisture. When the surface rails deteriorate sufficiently, the transformer will eventually experience electrical failure [37].

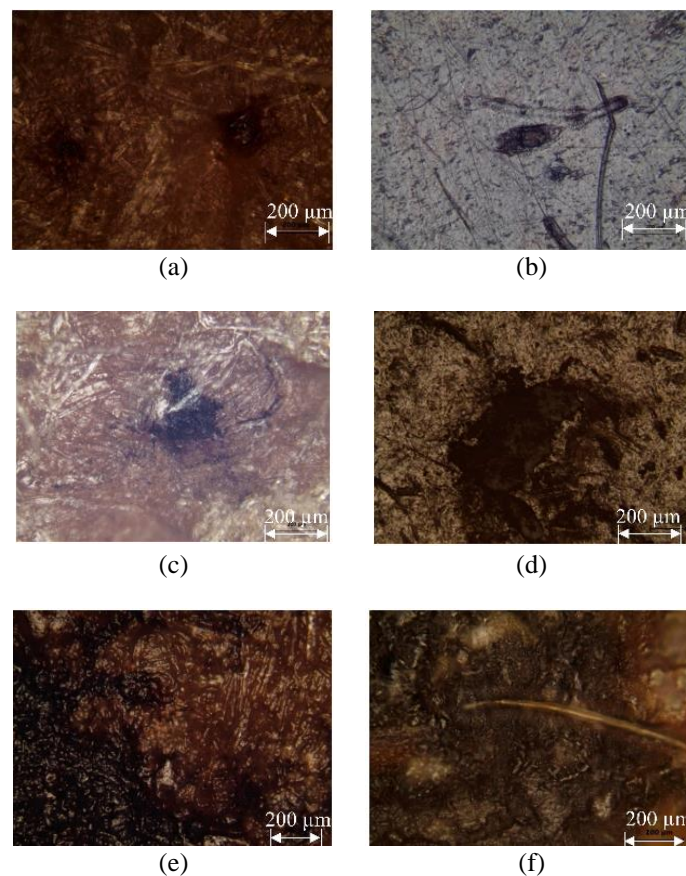

Figure 10. Surface deterioration impact from partial discharge measurement (a) NP0, (b) KPP0, (c) NP1, (d) KPP1, (e) NP3, and (f) KPP3

4. CONCLUSION

Under 0%, 1%, and 3% moisture conditions, the PD measurement was successfully completed for KPP and NP over a period of six hours. Based on the statistical analysis and PD magnitude in the PRPD pattern, the PD features were examined. The findings showed that for each moisture condition, KPP has better PD mitigation efficiency than NP. KPP demonstrated 89%, 83%, and 25% decreases in average PD magnitude at moisture levels of 0%, 1%, and 3%, respectively. Additionally, the presence of moisture in KPP and NP has had a substantial impact on the development of PD. At 0% and 1% moisture, there was no discernible difference in PD magnitude between the two types of pressboard. However, at the greatest moisture level indicating wet insulation (3%), it has sharply grown to more than 80%. In terms of surface deterioration, both pressboards were affected by PD occurrences. Carbon tracks were also formed on KPP and NP surfaces with a maximum moisture content of 3%. Overall, KPP has better electrical properties than NP when it comes to stopping PD from happening.

ACKNOWLEDGEMENTS

This research was fully supported by Universiti Teknologi Malaysia and Sriwijaya University, grant numbers 01M73, 16J61, 4B383, 07G05, 04G81, 4B377, 4B340, 4B341, and 4B342.





REFERENCES

- [1] M. F. Baharuddin *et al.*, "Effect of surfactant on breakdown strength performance of transformer oil-based nanofluids," *Journal of Electrical Engineering and Technology*, vol. 14, no. 1, pp. 395–405, Jan. 2019, doi: 10.1007/s42835-018-00028-2.
- [2] R. Chandrashekar, S. E. Chaudhari, P. K. Bajpai, and R. Mehta, "Developments in insulating paper for power transformers," *Journal of Chemical Engineering*, 2011.
- [3] T. A. Prevost and T. V. Oommen, "Cellulose insulation in oil-filled power transformers: Part I - History and development," *IEEE Electrical Insulation Magazine*, vol. 22, no. 1, pp. 28–34, Jan. 2006, doi: 10.1109/MEI.2006.1618969.
- [4] L. Naranpanawe, C. Ekanayake, and T. K. Saha, "Measurements on pressboard to understand the effect of solid insulation condition on monitoring of power transformer winding clamping pressure," *IET Science, Measurement and Technology*, vol. 13, no. 2, pp. 186–192, Mar. 2019, doi: 10.1049/iet-smt.2018.5096.
- [5] N. I. M. Zawawi, A. Z. M. Asa'ari, L. C. Abdullah, H. H. Abdullah, J. Harun, and M. Jawaid, "Water absorbency and mechanical properties of kenaf paper blended via a disintegration technique," *BioResources*, vol. 8, no. 4, pp. 5570–5580, Sep. 2013, doi: 10.15376/biores.8.4.5570-5580.
- [6] P. Zukowski, T. N. Koltunowicz, K. Kierczyński, J. Subocz, M. Szrot, and M. Gutten, "Assessment of water content in an impregnated pressboard based on DC conductivity measurements theoretical assumptions," *IEEE Transactions on Dielectrics and Electrical Insulation*, vol. 21, no. 3, pp. 1268–1275, Jun. 2014, doi: 10.1109/TDEI.2014.6832274.
- [7] W. Sikorski, K. Walczak, and P. Przybyłek, "Moisture migration in an oil-paper insulation system in relation to online partial discharge monitoring of power transformers," *Energies*, vol. 9, no. 12, p. 1082, Dec. 2016, doi: 10.3390/en9121082.
- [8] T. Islam, Z. Tehseen, and L. Kumar, "Highly sensitive thin-film capacitive sensor for online moisture measurement in transformer oil," *IET Science, Measurement and Technology*, vol. 14, no. 4, pp. 416–422, Jun. 2020, doi: 10.1049/iet-smt.2019.0319.
- [9] E. P. Walidi, A. Aulia, A. Hazmi, H. Abrial, S. Arief, and M. H. Ahmad, "An optimized method of partial discharge data retrieval technique for phase resolved pattern," *TELKOMNIKA (Telecommunication Computing Electronics and Control)*, vol. 14, no. 1, p. 21, Mar. 2016, doi: 10.12928/telkomnika.v14i1.2602.
- [10] B. Sparling and J. Aubin, "Assessing water content in insulating paper of power transformers," *Physics*, vol. 11, no. Figure 1, pp. 1–5, 2007, [Online]. Available: http://electricenergyonline.com/show_article.php?mag=44&article=333.
- [11] T. M. F. Rahman, B. N. Rao, and P.M. Nirgude, "Influence of moisture on partial discharge characteristics of oil impregnated pressboard under non-uniform field," in *The 20th International Symposium on High Voltage Engineering, Buenos Aires, Argentina*, 2017, pp. 1–6.
- [12] W. Zhang, Z. Li, G. Ji, J. Guo, and Y. Yang, "Partial discharges behaviors of internal void in the oil-paper insulation and its effect on the material," in *Proceedings of the 2015 International conference on Applied Science and Engineering Innovation*, 2015, vol. 12, doi: 10.2991/asei-15.2015.229.
- [13] R. H. Khawaja and T. R. Blackburn, "Partial discharge patterns in oil-impregnated paper and pressboard insulation at high temperature," 2008.
- [14] A. K. F. Schober and S. Harrer, "Conductivity of Pressboard for HVDC Insulation Systems," *International Journal of Electrical and Computer Engineering Systems*, vol. 4, no. 2, 2013.
- [15] S. M. Jani and K. Izran, "Mechanical and physical properties of low density kenaf core particleboards bonded with different resins," *Journal of Science and Technology*, vol. 4, no. 1, pp. 17–32, 2012.
- [16] K. Chen, D. K. Liu, X. Wang, and T. J. Xia, "The hot-ageing property of electric insulating paper and press board of O-A kenaf bast fibre," in *[1991] Proceedings of the 3rd International Conference on Properties and Applications of Dielectric Materials*, 1992, pp. 458–461, doi: 10.1109/icpadm.1991.172096.
- [17] H. P. S. Abdul Khalil, A. F. I. Yusra, A. H. Bhat, and M. Jawaid, "Cell wall ultrastructure, anatomy, lignin distribution, and chemical composition of Malaysian cultivated kenaf fiber," *Industrial Crops and Products*, vol. 31, no. 1, pp. 113–121, Jan. 2010, doi: 10.1016/j.indcrop.2009.09.008.
- [18] I. Kamal *et al.*, "Kenaf For Biocomposite : An Overview," *Journal of Science and Technology*, vol. 6, no. 2, pp. 41–66, 2014, [Online]. Available: <https://publisher.uthm.edu.my/ojs/index.php/JST/article/view/796>.
- [19] A. A. Suleiman, "Performance of dielectric properties due to the presence of moisture in vegetable insulation oils and kraft paper immersed in the oils," Ph.D. dissertation, Universiti Teknologi Malaysia, Johor Bahru, Malaysia, 2015.
- [20] D. F. García, B. García, J. C. Burgos, and N. García-Hernando, "Determination of moisture diffusion coefficient in transformer paper using thermogravimetric analysis," *International Journal of Heat and Mass Transfer*, vol. 55, no. 4, pp. 1066–1075, Jan. 2012, doi: 10.1016/j.ijheatmasstransfer.2011.10.004.





- [21] M. Di Lorenzo del Casale, R. Schifani, and J. T. Holboll, "Partial discharge tests using CIGRE method II," *IEEE Transactions on Dielectrics and Electrical Insulation*, vol. 7, no. 1, pp. 133–140, 2000, doi: 10.1109/94.839351.
- [22] J. Yan, R. Liao, L. Yang, and M. Zhu, "Measurements and analysis of surface damage on oil-impregnated insulation," *Measurement Science and Technology*, vol. 22, pp. 1–10, 2011.
- [23] Z. Nawawi, Y. Muramoto, N. Hozumi, and M. Nagao, "Effect of humidity on partial discharge characteristics," in *Proceedings of the IEEE International Conference on Properties and Applications of Dielectric Materials*, 2003, vol. 1, pp. 307–310, doi: 10.1109/icpadm.2003.1218413.
- [24] M. M. Mohsin, M. N. Narayanachar, and R. S. Nema, "Study of partial discharge characteristics in oil impregnated pressboard insulation," in *Conference Record of IEEE International Symposium on Electrical Insulation*, 1996, vol. 1, pp. 79–82, doi: 10.1109/elinsl.1996.549287.
- [25] J. Dai, Z. Wang, and P. Jarman, "Creepage discharge on insulation barriers in aged power transformers," *IEEE Transactions on Dielectrics and Electrical Insulation*, vol. 17, no. 4, pp. 1327–1335, Aug. 2010, doi: 10.1109/TDEI.2010.5539705.
- [26] J. Li, W. Si, X. Yao, and Y. Li, "Partial discharge characteristics over differently aged oil/pressboard interfaces," *IEEE Transactions on Dielectrics and Electrical Insulation*, vol. 16, no. 6, pp. 1640–1647, Dec. 2009, doi: 10.1109/TDEI.2009.5361584.
- [27] M. J. Saad and I. Kamal, "Kenaf core particleboard and its sound absorbing properties," *Journal of Science and Technology*, no. February 2013, pp. 23–34, 2013.
- [28] M. L. S. S. M. Sapuan, J. Sahari, and M. R. Ishak, *Kenaf Fibers and Composites*, Vol. 1, 1s. Boca Raton, Florida, USA: CRC Press, 2018.
- [29] S. M. Batouli, Y. Zhu, M. Nar, and N. A. D'Souza, "Environmental performance of kenaf-fiber reinforced polyurethane: A life cycle assessment approach," *Journal of Cleaner Production*, vol. 66, pp. 164–173, Mar. 2014, doi: 10.1016/j.jclepro.2013.11.064.
- [30] Z. Yusoff and Z. Mohamad, "Review of Research Activities on Kenaf Reinforced," *Journal of Petrochemical Engineering Department*, vol. 1, no. 1, pp. 25–33, 2015.
- [31] H. I. Hideo Fujita, "Electrical insulating paper and method of making same," U.S. Patent No. 4,096,313, 1978.
- [32] IEEE Std 62-1995 (R2005), "IEEE Guide for diagnostic field testing of electric power apparatus- Part 1: oil filled power transformers, regulators, and reactors," *Mayo 2013*, vol. 1995, pp. 1–59, 2005.
- [33] M. H. Ahmad *et al.*, "Temperature Effect on electrical treeing and partial discharge characteristics of silicone rubber-based nanocomposites," *Journal of Nanomaterials*, vol. 2015, pp. 1–13, 2015, doi: 10.1155/2015/962767.
- [34] M. G. Niasar, N. Taylor, P. Janus, X. Wang, H. Edin, and R. C. Kiiza, "Partial discharges in a cavity embedded in oil-impregnated paper: Effect of electrical and thermal aging," *IEEE Transactions on Dielectrics and Electrical Insulation*, vol. 22, no. 2, pp. 1071–1079, Apr. 2015, doi: 10.1109/TDEI.2015.7076808.
- [35] J. V. Champion, S. J. Dodd, and J. M. Alison, "The correlation between the partial discharge behaviour and the spatial and temporal development of electrical trees grown in an epoxy resin," *Journal of Physics D: Applied Physics*, vol. 29, no. 10, pp. 2689–2695, Oct. 1996, doi: 10.1088/0022-3727/29/10/023.
- [36] H. A. S. M. Saleh *et al.*, *Kenaf-A potential fibre for pulp and paper manufacture*. Kuala Lumpur, Malaysia: Malaysian Timber Industry Board, 2012.
- [37] Y. Cheng, C. Li, and Y. Miao, "The relationship between surface partial discharge and carbon trace in oil-impregnated paper insulation," in *Annual Report - Conference on Electrical Insulation and Dielectric Phenomena, CEIDP*, Aug. 2009, pp. 96–99, doi: 10.1109/CEIDP.2009.5377710.

BIOGRAPHIES OF AUTHORS





Rizda Fitri Kurnia     was born in South Sumatera Province, Indonesia in 1987. She graduated with a B.S. in electrical engineering from the University of Sriwijaya of Indonesia, Palembang in 2008, and M.Eng in electrical engineering from Universiti Teknologi Malaysia (UTM), Johor Bahru in 2010, and is currently a Ph.D. student of UTM. She is a lecturer at the University of Sriwijaya's Electrical Engineering department. Her areas of interest in study are nanodielectrics, partial discharge phenomena, and high voltage engineering. She can be contacted at email: Usman. rizda@unsri.ac.id.





Norhafezaidi Mat Saman     was born in Ipoh, Perak, On July 10, 1995. In 2018, he graduated with first-class honors from Universiti Teknologi Malaysia (UTM) in Malaysia with a B. Eng. in electrical engineering. At the moment, he is working on his Ph.D. in Electrical Engineering at Malaysia's Universiti Teknologi Malaysia in Johor. His study focuses on insulations made of nanocomposites and plasma applications. The insulation diagnostic investigation for medium- and high-voltage applications is another topic he covers. He can be contacted at email: hafezaidimatsaman@gmail.com.





Mohd Hafizi Ahmad    awarded the B. Eng. and Ph.D. degrees in electrical engineering in 2009 and 2013, respectively, from the Universiti Teknologi Malaysia, Johor Bahru, Malaysia. He worked as a visiting researcher at Tanjungpura University in Pontianak, Indonesia, Sriwijaya University in Palembang, Indonesia, and the University of Leicester in Leicester, United Kingdom. In Kuala Lumpur, Malaysia, he worked as a Technical Advisor for Global Testing Services (M) Sdn Bhd and as a Principal Consultant for Maha Power Sdn Bhd. He leads testing and calibration as Manager at IVAT UTM, where he also participates in numerous calibration and testing projects involving high-voltage machinery. The Malaysia Board of Technologists recognizes him as a Registered Professional Technologist (MBOT). His work focuses on nanodielectrics, plasma applications, conventional and novel partial discharge measurements, as well as condition monitoring and diagnostic methods. Mr. Ahmad belongs to the IET, UK, CIGRE, and IEEE. He can be contacted at email: mohdhafizi@utm.my.





Zainuddin Nawawi    was born in Lubuk Linggau, South Sumatera, Indonesia in 1959. In 1984, he awarded a B.S. in electrical engineering from the Universitas Sriwijaya in Palembang, Indonesia, and in 2011, he awarded a Ph.D. in electrical engineering from the Universiti Teknologi Malaysia (UTM) in Malaysia. He is currently a professor at the University of Sriwijaya's Electrical Department. His areas of interest in study include insulation of materials, high voltage system protection, and high voltage phenomena. He can be contacted at email: nawawi_z@yahoo.com.



Nur Azalia Azrin    was born in Kuala Lumpur on 2nd January 1993. She graduated from UTM in 2016 and received a bachelor's degree with honour in electrical engineering. In 2019, she was awarded a master of philosophy in electrical engineering from UTM. She has experience working with Tenaga Nasional Berhad (TNB) in the strategy and regulatory division. Currently, she is a full-time PhD student at the Institute of High Voltage and High Current (IVAT), UTM Johor Malaysia. Her research area emphasises environmental friendly materials for insulation application. She had introduced a kenaf-based pressboard for transformer insulation. Recently, she explores polypropylene-based cable insulation. She can be contacted at email: azzaleeya93@gmail.com.



Mohd Aizam Talib    received his Bachelor in Electrical Engineering in 1997 and PhD in Electrical Engineering in 2016. He previously held the responsibilities of Senior Research Engineer, Manager for the High Voltage Testing Laboratory, and Senior Technical Expert with TNB Research Sdn Bhd (Transformer). He is currently TNB Labs Sdn Bhd's Head of Advanced Diagnostic Services. He has more than 24 years of expertise working with power transformer research, testing, diagnosis, and life assessments. At national and international journals and conferences, he has published and presented various technical papers on transformer diagnosis and condition assessment. He can be contacted at email: aizam.talib@tnb.com.my.