

# Unified power quality control based microgrid for power quality enhancement using various controlling techniques

Mythreyee Madhavan, Nalini Anandan

Department of Electrical and Electronics Engineering, Dr. M.G.R. Educational and Research Institute, Chennai, India

## Article Info

### Article history:

Received Aug 8, 2022

Revised Sep 3, 2022

Accepted Sep 12, 2022

### Keywords:

Compensator

Microgrid

Power quality issues

Series and shunt compensator

Total harmonic distortion

Unified power quality control

Voltage sag and swell

## ABSTRACT

This research analyses the introduction of unified power quality control (UPQC) to mitigate the power quality problems, which is caused by using power electronics devices. In this article, the challenges in power quality, the suggested UPQC control approaches that are made by the distributed generation of dynamic voltage restorer (DVR) and static synchronous compensator (STATCOM) with the DC-link. The DVR is a series active power filter (APF) compensator and the STATCOM is a shunt APF compensator. In the meanwhile, DVR compensates voltage related issues as well as STATCOM provides the needed reactive power supply by load and reducing the current issues associated with the unity power factor. The main objectives of the UPQC to mitigate voltage imbalance, harmonics, negative-sequence current and reactive power. To overcome the PQ issues the multifunction power conditioner is implemented. In addition, several proposed control approaches were employed and compared with series and shunt APFs. In MATLAB/Simulink software is used to illuminate the performance of the control strategies. Finally, the simulation will be evaluated and PQ problems in UPQC will be reduced by various techniques such as unit vector template generation technique (UVTGT), power balancing theory (BPT), proportional integral (PI) control technique and hysteresis control technique.

This is an open access article under the [CC BY-SA](https://creativecommons.org/licenses/by-sa/4.0/) license.



## Corresponding Author:

Mythreyee Madhavan

Department of Electrical and Electronics Engineering, Dr. M.G.R. Educational and Research Institute

Maduravoyal, Chennai, Tamil Nadu, India

Email: mythreyee.phd@gmail.com

## 1. INTRODUCTION

Distributed generation systems can supply electricity to the traditional grid, microgrid, or smart grid. That can become a major issue of unpredictable weather conditions so that the system produces high fluctuations, instability, poor voltage regulation, and low reliability. To overcome these issues, power electronics devices are used to integrate into the systems like rectifiers, inverters, and capacitor banks by this integration, power quality issues are rising from the system, such as current and voltage-based issues, such as voltage swell and sag, interruptions, poor power factor, harmonic distortion and imbalance in the output efficiency. To tackle the operations of the power system, flexible alternating current transmission system (FACTS) devices were familiarized [1]. Unified power quality control (UPQC) is one of the FACTS family to compensate for the different voltage problems of the power supply and harmonic distortion problems. This is examined in a 10 kV distributed network. Solar photovoltaic (PV), wind energy and fuel cell-based microgrid system were designed and analyzed the power quality issues and improved using UPQC with p-q and d-q theory [2]. In modern trends, custom power system devices are used for power electronic controllers based on static synchronous compensator (DSTATCOM), dynamic voltage restorer (DVR), and UPQC. DVR is

applicable for the economic losses problem and is cost-effective [3]. Current and voltage-related issues are also mitigated by the series and shunt active power filter, which has a standard limit of  $\pm 5\%$  [4]. The development of the algorithm of an instantaneous reactive power theory for a shunt compensator, its implementation, and an evaluation of power quality indices to demonstrate the mitigation of power quality in distribution system. Total harmonic distortion (THD), power factor, and efficiency are evaluated using various control techniques [5].

This FACTS device can compensate for the load voltage and grid current at the unity power factor at the same time [6]. Solar PV array with UPQC is utilized with series and shunt active power filter (APF) to eliminate the PQ issues. Also, the THD analysis of the grid current is obtained, which is within the limit of IEEE standard of 519 and 11,159 [7]. Moreover, the optimal location of the system is allocation of the distribution side, which is installed a FACTS device is called a DFACTS [8]. FACTS devices are used for voltage regulation in a microgrid, the STATCOM is designed in bus A. The new features enhance the benefits of the UPQC the grid can cut down the current regulation on the inner loop circulating power [9]. DVR is analyzed under different configurations in solution for power quality enhancement by APF, consisting of the transformer, voltage source inverter (VSI), battery, and bypass switch. To enhance the DVR performance, Flowering locus C (FLC), artificial neural network (ANN), and space vector control can be integrated [10]. Furthermore, the designed system can be used with various control techniques, and all the methods are simulated in MATLAB/Simulink sim scape power system software tool. This simulated system compensates for the high power load like 250 MVA consisting of dynamic load and direct torque control (DTC) motor drive [11]. The analysis and presented of an automatic transition of a solar PV array and battery incorporated UPQC (PV-B-UPQC) between independent and associated to grid operating modes [12]. Similarly, modification of gain parameters of four proportional integral (PI) controllers in the STATCOM control circuit using evolutionary algorithms and the bacteria foraging algorithm [13], resulting in improved responses and voltage stability due to the non-linear nature of the solar-wind hybrid micro-grid [14]. This study describes the smart metering installation in domestic access with proper communication [15]. The PQ improvement in renewable sources microgrid employed fuzzy logic theory to improve the dq reference currents, which were then used to construct space vectors with appropriate sector selection purpose of providing precise pulse width modulation (PWM) signals for inverter control [16].

The power compensator is employed for an improved and more efficient control strategy, such as voltage and current regulation of the microgrid circuit, and it employs a convolutional neural network (CNN) having long short-term memory to achieve superior time consumption indicators [17], [18]. The use of the reweighted zero attracting technique, which exhibits good steady-state and transient performance. A novel state observer based SMC for UPQC inverters is intended to be resilient in the face of parameteric and external uncertainty. Using the proposed design, UPQC gained active and reactive power injection capabilities in addition to its well-known benefit. Experiments were carried out in various circumstances to validate the efficacy of the suggested strategy in increasing power quality metrics [19], [20]. In series circuit is controlled by DVR, and the voltage varies in response to load variations, which are assessed using the suggested rational energy transformative optimization algorithm [21]. This method supplies the appropriate PWM to the VSI, which creates and absorbs real power (P) or reactive power (Q) separately. DVR loads are affected by separate injection voltage recovery line voltages [22]. To enhance the PQ parameters connected with the MG system, the Bayesian regularisation approach is employed to train the ANN controller associated with the DSTATCOM [23].

To address the PQ concerns associated with an AC MG incorporating a PV array and a wind energy producing unit, an ANN-based DSTATCOM controller has been developed. This analysis takes into account three PQ parameters: system frequency, total harmonic distortion, and PCC voltage. Recently, power quality effect mitigation strategies that take use of bidirectional power flow from car to grid and grid to vehicle grid-to-vehicle have been explored [24]. Methods and techniques for addressing power quality issues in the EV-enabled distribution system are explored.

Development and construction of distributed systems of control for AC, DC and hybrid AC/DC microgrids distributed controllers are said to have numerous benefits over centralized control schemes [25]. Model predictive controller for the wind energy conversion system that is connected to the grid. The system has wind energy as its input, and its AC source is converted into DC by a rectifier [26]. Multipath delay commutator fast fourier transform has been proposed for enhancing the throughput and speed [27].

Consequently, this paper describes the system configuration in session 2, which consists of the operation and design of UPQC in a hybrid microgrid. Session 3 discusses the various controlling techniques with suitable control blocks. Then the main work of this work, simulation, and result studies were presented in session 4 with a suitable design for the proposed system. Also, the performance is analyzed by the results of the simulated system. Finally, the conclusion is discussed in session 5.

**2. SYSTEM CONFIGURATION**

The designed system is implemented by the source of hybrid wind energy conversion system and solar PV with battery. This hybrid sources is connect with the transmission line. Using power electronic devices, power quality issues are produced. To overcome this power quality issues, implement the UPQC.

**2.1. Unified power quality conditioner (UPQC)**

UPQC is a multifunctional power conditioner, also known as the universal active filter. Combination of series and shunt APF compensator with DC-link capacitor are used as an advanced version of the UPFC, which is utilized to mitigate the current related problems, voltage related problems, harmonic distortion and delivers the Q to enhance the unity power factor to the power system. The power supplied is linked through a shared DC connection, ensuring continual actual power exchange. The reactor is used to connect the DC connection. Specifically, the series APF is controlled the voltage source in the manner of mitigating the voltage sag, voltage swell, voltage interruption, and voltage harmonics. Shunt APF injects the compensating current to the current source through a transformer. The APFs are separated by the distributed generations, as shown in Figure 1.

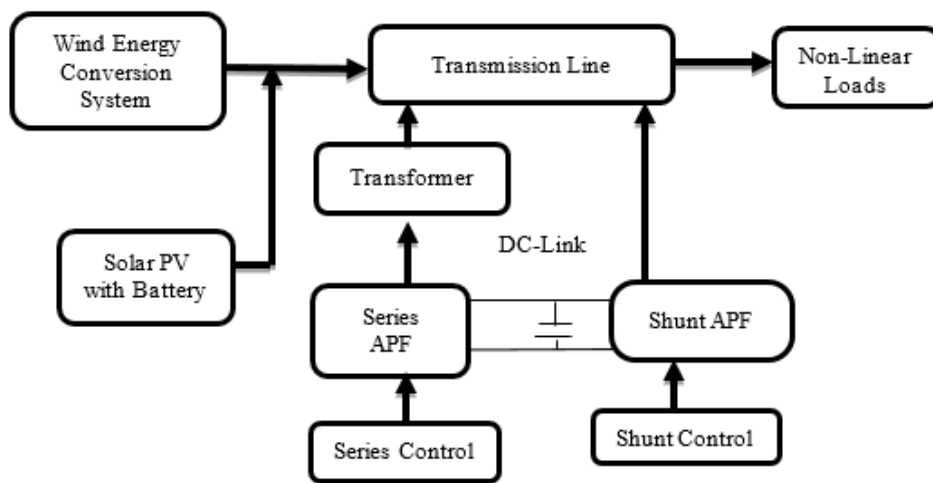

Figure 1. Proposed block diagram of UPQC based microgrids

**2.2. Operations of UPQC**

The mathematical modeling of the UPQC is analyzed, and the power flow is separately operated by the power supply, series APF, and shunt APF. Consider the microgrid power system is supply by Kirchhoff's law, in (1) and (2):

$$V_{abc} = V_s - L_s \frac{di}{dt} - R_s i_{line} - V_{osr} \tag{1}$$

$$i_{line} = i_L - i_{sh} \tag{2}$$

where  $V_{abc}$  phase voltage of the power system,  $V_s$  is source voltage,  $L_s$  and  $R_s$  are inductance and resistance of the transmission line,  $i_{line}$  is line current,  $V_{osr}$  is the output voltage of series APF,  $i_L$  is load current,  $i_{sh}$  is shunted current of the Shunt APF.

The voltage injected by series APF is expressed in (3) and (4):

$$V_{inj,sr} = V_{Lref} - V_t = -V_L K \angle 0 \tag{3}$$

$$K = \frac{V_t - V_L}{V_L} \tag{4}$$

where APF's are used to control the voltage swell and sag,  $V_{Lref}$  is reference load voltage,  $V_t$  is terminal voltage. The injected voltage from the series APF is considered as  $V_{Lref}$ . And the power factor (PF) of the load is  $\cos\phi_L$  which provides nearly unity PF, which is the source current, the factor 'K' represents the fluctuations of the source voltage in (5).

$$i_s = \frac{i_L}{1+K} \cos\phi_L \quad (5)$$

The complex apparent power absorbed by the series and shunt APF can be expressed in (6) and (7),

$$S_{sr} = P_{sr} + jQ_{sr} \quad (6)$$

$$S_{sh} = V_L * i_{sh} \quad (7)$$

$$\text{Where, } P_{sr} = V_{sr} * i_s * \cos\phi_s \quad (8)$$

$$Q_{sr} = V_{sr} * i_s * \sin\phi_s \quad (9)$$

where  $P_{sr}$  and  $Q_{sr}$  are the real/active (P) and reactive power (Q) of the series APF absorbs, in (8) and (9),  $i_{sh}$  is the difference between the current source and load current, including harmonics load current and Q.

### 2.3. Design of UPQC

$V_{dc}$  is the magnitude of the DC-link voltage, depending upon the depth of the modulation (m) is 1. The line voltage of the grid ( $V_{line}$ ) is 400 V, the gain DC-link voltage is 653 V since the  $V_{dc}$  should have more than twice the  $V_{line}$ . So, the  $V_{dc}$  should be set as approximately 700 V.  $C_{dc}$  is the capacitor of the DC-bus, which is based on the requirement of the DC-bus voltage. Where  $V_{ph}$  is phase voltage (350 V),  $i_{sh}$  is shunt current (29.36 A),  $a_f$  is overloading factor =1.2,  $k_e$  is energy factor (0.1), and  $t$  is the minimum time (30 ms).  $L_{sr}$  is the series compensator inductor depending on the  $f_{sr}$  is switching frequency (10 kHz),  $i_r$  is a ripple current of the grid, and  $K_{sr}$  is series injection 3.  $L_{sh}$  is the shunt compensator inductor. The parameters are represented in Table 1. As per the parameters of the UPQC, the system is implemented, which is represented in block diagram.

Table 1. Parameters of UPQC

Parameters	Equations	Values
$V_{dc}$	$2\sqrt{2}V_{line}$	653 V
$C_{dc}$	$\frac{\sqrt{3} * m}{3 V_{ph} i_{sh} a_f k_e t}$	2100 mF
$L_{sr}$	$\frac{1}{2} (V_{dc, set}^2 - V_{dc}^2)$ $\frac{\sqrt{3} m V_{dc, set} K_{se}}{12 a_f * f_{sr} * i_{rsr}}$	3.6 mH
$K_{sr}$	$\frac{V_{line}}{\sqrt{3} * V_{sr}}$	3
$L_{sh}$	$\frac{\sqrt{3} m V_{dc, set}}{12 a_f * f_{sh} * i_{rsh}}$	3 mH

## 3. CONTROLLING TECHNIQUES

Reference signals for the control of both series APF and shunt APF components of the UPQC have to be designed accordingly using several control algorithms usually used to control the STATCOM and DVR. The control algorithms are classified into two such as the time domain and the frequency domain. In this research work, we deal with time-domain controlling techniques.

### 3.1. Unit vector template generation technique (UVTGT)

This is series APF-based control, which is used to reduce the controller burden as well as this is very easy to implement. This control method does not need PI tuning. 3 phase phase-locked loop (PLL) is used to generate  $wt$  corresponds to the voltage source (reference phase). When  $wt$  is sum up with  $\delta_s$  in the estimator block of the power angle, which is used to generate 3 phase balanced unit vector because time varies concerning amplitude shown in 10. The simulation diagram is shown in Figure 2.

$$\begin{bmatrix} U_a \\ U_b \\ U_c \end{bmatrix} = \begin{bmatrix} \sin(wt + \delta_s) \\ \sin(wt + \delta_s - 2\pi/3) \\ \sin(wt + \delta_s + 2\pi/3) \end{bmatrix} \quad (10)$$

The reference series voltage signal is generated by the reference amplitude of the source voltage and provides the product with the unit vectors. The switching pulses for the VSC MOSFETs are generated using a fixed frequency carrier-based sinusoidal PWM. This approach is based on the unit vector template technique. Then the sensed series and  $V_s$  signals are provided to hysteresis control of series APF.

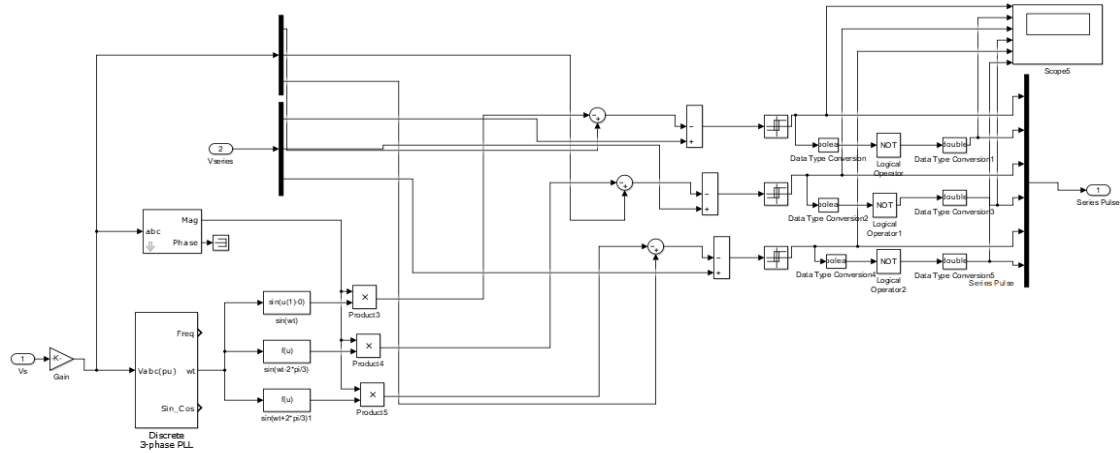

Figure 2. Simulation diagram of UVTG control method

**3.2. Hysteresis control technique**

This control technique generates the switching pattern of the inverter, which is connected in shunt APF. This control method is a simple and easy method to implement and understand the stability of the systems unconditionally. This method depends upon the reference and injected current from the control signal. The switching pattern decides by the hysteresis current controller. This operation is set as the reference current, where the error gets close to the upper limit bands, then the current automatically decreases. When the error goes to a lower limit, the current automatically increases the corresponding structure, which is shown in Figure 3.

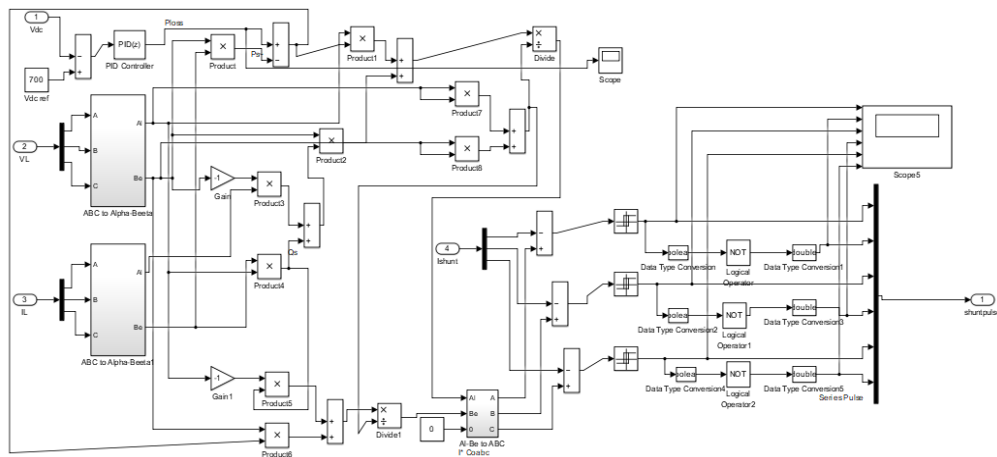

Figure 3. Simulation diagram of hysteresis control technique

**3.3. Power balance theory (BPT)**

The power balance theory is based on the shunt APF compensator, here the  $V_{sabc}$ ,  $I_{sabc}$  source voltages, and source current are transformed to  $I_{ref(abc)}$  using Clarke transform. Figure 4 shows the block diagram. In clark transformation, the unit vector reference in-phase current is expressed in (11),

$$V = \sqrt{\frac{2}{3}} * (V_a^2 + V_b^2 + V_c^2) \tag{11}$$

where the terminal voltage is  $V_t$  at PCC in (12).

$$V_{ta} = V_a, V_{tb} = V_b, V_{tc} = V_c \tag{12}$$

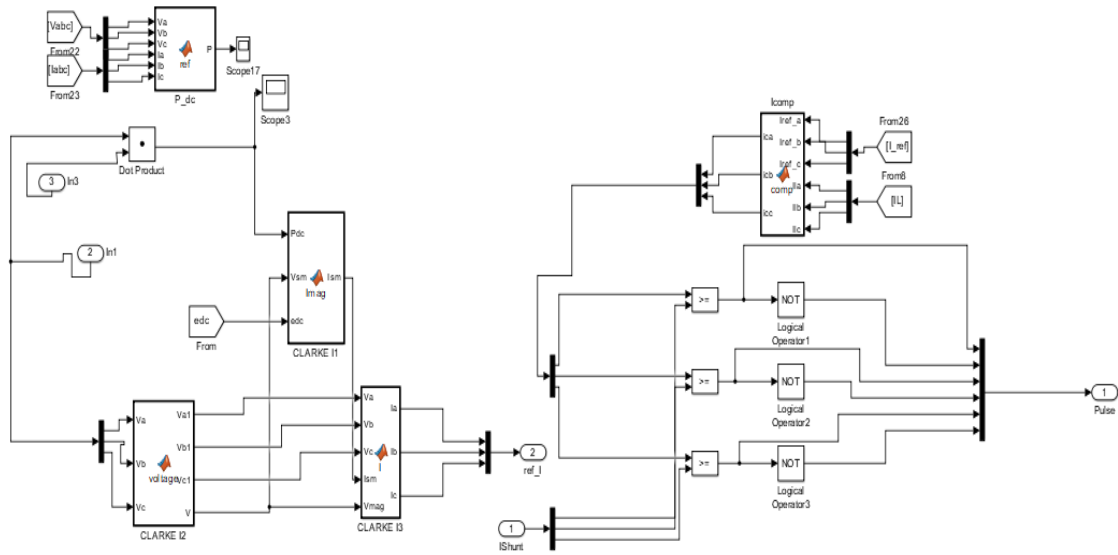

Figure 4. Simulation diagram of BPT

$$I_{smp} = \frac{2}{3} * (P_{dc}/V) \tag{13}$$

$$I_{smd} = \frac{2}{3} * (V_{dc}/V) * (6 * 50) \tag{14}$$

$$I_{sm} = I_{smp} + I_{smd} \tag{15}$$

Where  $I_{smp}$  and  $I_{smd}$  are the magnitude of the source current in the p domain and d domain respectively.  $P_{dc}$  is the reference power to Voltage, likewise, the d domain current represents the  $V_{dc}$  to  $V$  with switching frequency with switches. Finally, the magnitude of the source current is a product of  $I_{smp}$  and  $I_{smd}$ . They are described in (13)-(15).

$$\begin{bmatrix} I_{ref,a} \\ I_{ref,b} \\ I_{ref,c} \end{bmatrix} = \frac{I_{sm}}{V} \begin{bmatrix} V_a \\ V_b \\ V_c \end{bmatrix} \tag{16}$$

The current compensation  $I_{ca}$  calculation is illustrated in (16). Then, the reference current control the signals from the transform and the controlled signals are given to the hysteresis controller with the shunt current ( $I_{sh(abc)}$ ). And the pulse is given to the shunt APF and the calculation is shown in (17).

$$\begin{bmatrix} I_{ca} \\ I_{cb} \\ I_{cc} \end{bmatrix} = \begin{bmatrix} I_{L,a} \\ I_{ref,a} \\ I_{L,b} \\ I_{ref,b} \\ I_{L,c} \\ I_{ref,c} \end{bmatrix} \tag{17}$$

### 3.4. PLL with PI control

Figure 5 shows the PI control block diagram. The PI controller is a very basic and simple controller, which consists of 3  $\emptyset$  phase-locked loops (PLL) from the voltage source  $V_{sabc}$ . The dq transform converts the abc to the dq domain from the voltage load abc  $V_{Labc}$ . The selector is used here to extract the signals to proportional integral (PI) with constant values, again the signal converts from the dq- abc domain. The pulse width modulation generator (PWM) is used here to control the signals and finally gives the pulse to the series APF compensator.

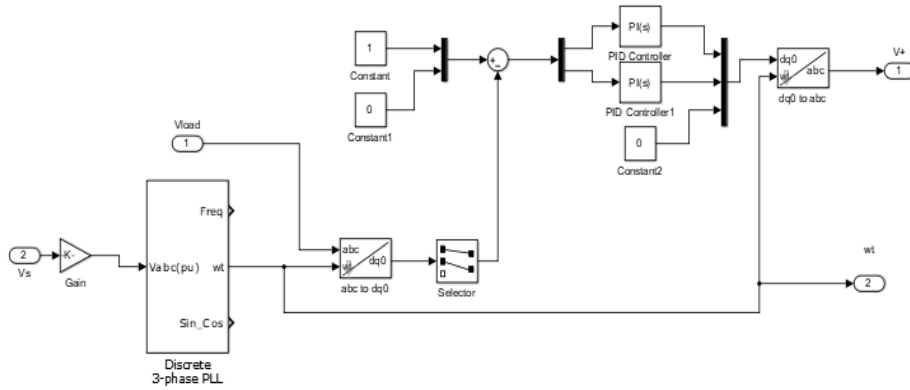

Figure 5. Simulations of PI control

4. SIMULATIONS AND RESULTS STUDIES

The hybrid microgrid is connected to the grid, which increases the power quality issues by the distributed system also produced by power electronic devices. The main problem is voltage fluctuation in the form of voltage sag and voltage swell. These voltage-related issues may mitigate using various control techniques done by DVR. Then the current related issues reduce by various techniques done by STATCOM. The proposed system of the UPQC-based microgrid is designed in MATLAB/Simulink with the Simscape software tool. Here the load is non-linear and consists of a three-phase universal bridge with MOSFET/Diodes as well as an R-L load with sufficient ratings. The solver type is Tustin with the discrete simulation type belongs to  $50e^{-6}$  sample time (s) as shown in Figure 6.

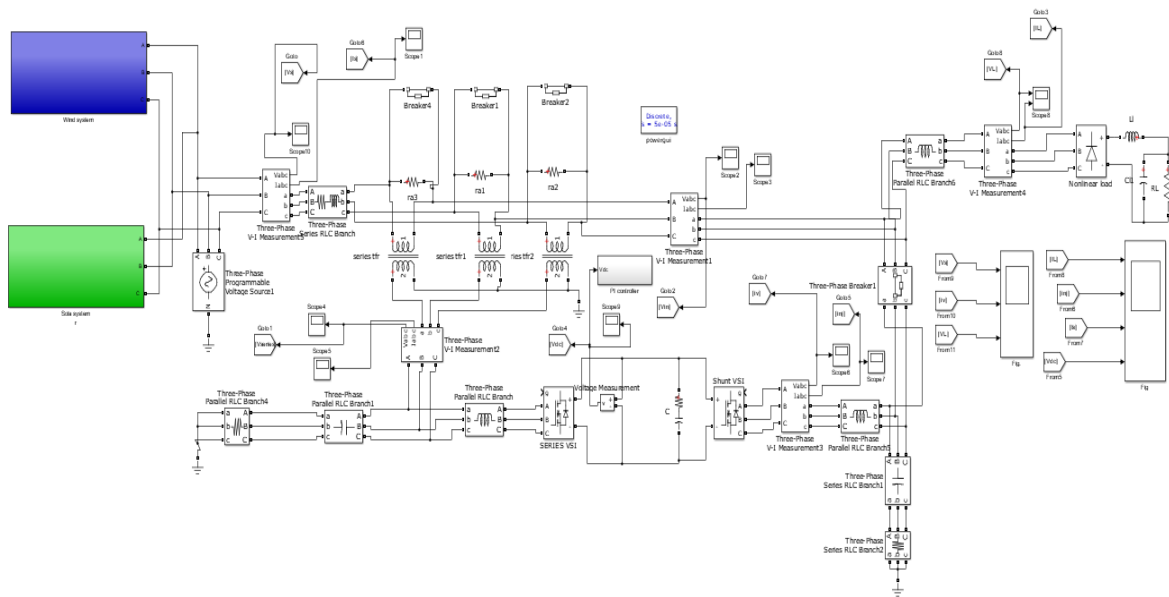

Figure 6. Proposed system of UPQC based microgrid

To begin with, the simulation of a hybrid microgrid without using UPQC compensator. The performance of the without using UPQC analysis is shown in Table 2. The performance of the system analysis conducts basic parameters such as source voltage  $V_s$ , source current  $I_s$ , load voltage  $V_L$  and load current  $I_L$ .

Table 2. Performance analysis of the system without UPQC

Parameter	THD%	THD%
Without APF	$V_s = 16.67$	$I_s = 12.08$
	$V_L = 17.77$	$I_L = 12.63$

#### 4.1. Performance analysis of UPQC with hybrid microgrid

The hybrid solar, wind, and battery are the source of the grid, which is connected with the UPQC compensator. On the load side, non-linear loads are connected with the rectifier. Here the series APF and shunt APF converter has placed in suitable places of the system. Without a UPQC system shows that has more power quality issues occurred like higher THD in voltages and currents with irrelevant real and reactive power values for this designed system with lower power factor. So, time domain-based controlling techniques were implemented to compensate for the power quality issues. Firstly, we proposed the UVTG technique in a series APF compensator, and the hysteresis control technique is employed with a shunt APF compensator shown in Figures 7 and 8.

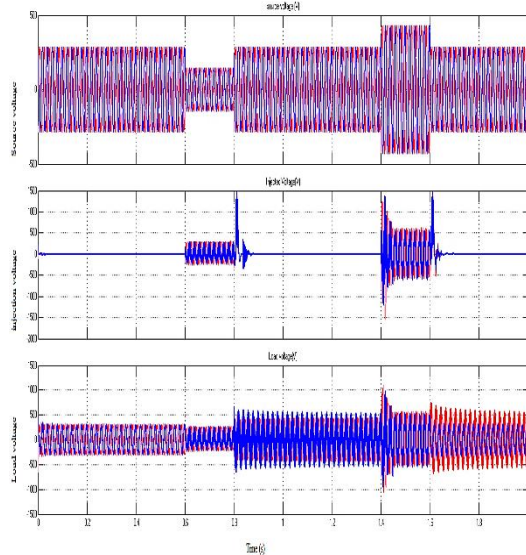

Figure 7. Voltage waveform

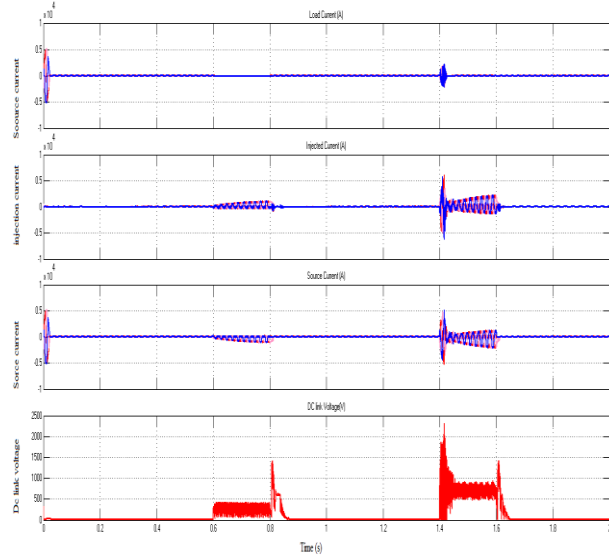

Figure 8. Current waveform

Here, Figure 7 first layered waveform represents that the fault condition is produced in the period of 0.6 to 0.8 seconds is represented as sag voltage and 1.4 to 1.6 seconds is defined as swell voltage. This is because of the fault, the amplitude gets reduce from 300 V to 200 V (sag) with a 0-degree phase angle and 50 Hz. Also, the amplitude gets increases from 300 V to 400 V (swell). At the time of fault condition, the UPQC with the proposed UVTG controller and hysteresis controller was used to analyze the performance. Figure 7 second layered waveform represents the injected voltage of 150 V (sag) and 300 V (swell) from the compensator to rectify the fault condition. Figure 7 third layered waveform shows that the faulted periods are rectified and supplied to the load voltage. Figure 8 represents the load current, injected current, source current, and DC link voltage respectively, where the peak DC-Link voltage is 500 V and 1,000 V. Table 3 presents the performance analysis of UVTG and hysteresis control technique.

Table 3. Performance analysis of UVTG and Hysteresis control technique based UPQC

Parameter	THD%	THD%	Power Factor (PF)
UPQC with UVTG and Hysteresis control	$V_s = 0.04$	$I_s = 0.01$	1
	$V_L = 3.10$	$I_L = 2.14$	1

Likewise, the other has been utilized in the series APF and shunt APF compensation in UPQC. PI controller is integrated into series APF and Power balance theory is integrated into shunt APF, as shown in Figures 9 and 10. Figure 9 represents the source voltage injected voltage and load voltage. The injected voltage injects the voltage to the sag and swell condition. The peak injected voltage to the sag is 150 V and injected voltage to the swell is 100 V. Figure 10 describes the injected current as 200 A and 400 A to the source current. Then the DC-link voltage is 50 V and 60 V to the shunt APF compensator, as shown in fourth layer waveform of Figure 10. Table 4 represents that the performance analysis of the UPQC-based PI and BPT control can mitigate the power quality issues, which are listed in the values below.

According to this analysis of the UPQC with various controllers can mitigate the power quality issues, where the THD of the source voltage can be more efficient in UVTG technique than PI series APF compensator



has 0.04% and the load voltage is 3.34%. Then the THD of the source current is 12.02% and 3.08% of load current in BPT is more effective than hysteresis control APF compensator. The power factor of the proposed system with proposed techniques was simulated with suitable requirements of the microgrid, which has 1 PF (unity power factor). This analysis illustrates that all the controlling techniques were executed in the proposed system due to the working condition of the system leads to PF sustainability.

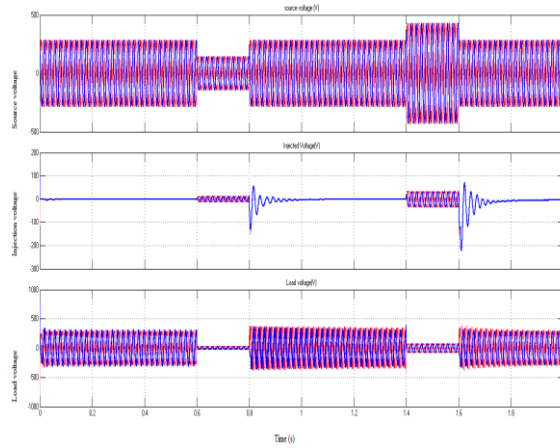

Figure 9. Voltage waveform for PI control

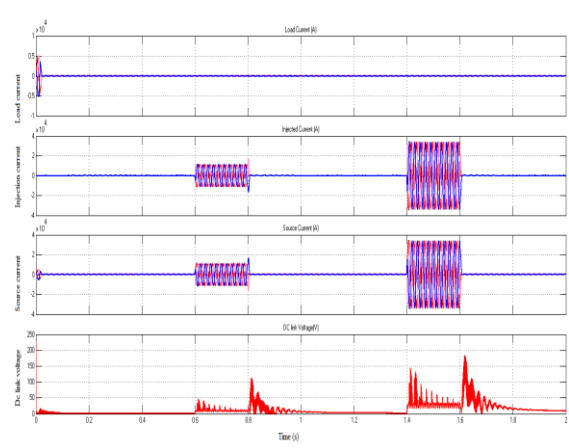

Figure 10. Current waveform for BPT

Table 4. Performance analysis of UPQC based PI and BPT

Parameter	THD%	THD%	Power Factor (PF)
UPQC with PI and BPT Control	$V_s = 0.01$	$I_s = 1.01$	1
	$V_L = 3.34$	$I_L = 3.08$	1

5. CONCLUSION

In this work, proposed hybrid microgrid-based UPQC with proposed controlling techniques were implemented. The system operates in isolation mode that maintains the power supply continuously to the loads. Since due to RES, the system provides the power quality issues, this proposed system mitigates the power quality issues and operates in stable condition. However, the behavior of the proposed system has been satisfactory also recommended THD limits within the IEEE-519 standard. Moreover, the hybrid microgrid with UPQC is satisfactory under various control techniques besides voltage sag/swell. The system operates properly in also under various disturbances. The system is suitable for non-linear loads such as domestic users, and data centres. and sensitive loads. Furthermore, the system was analyzed with various control techniques. All control techniques are working properly with IEEE standards and are demonstrated in MATLAB/Simulink. The future scope of this work is to take a bit longer analysis of all of India's national grids and compare it to the proposed hybrid microgrid.



REFERENCES

- [1] J. Yu, Y. Xu, Y. Li, and Q. Liu, "An inductive hybrid UPQC for power quality management in premium-power-supply-required applications," *IEEE Access*, vol. 8, pp. 113342-113354, 2020, doi: 10.1109/ACCESS.2020.2999355.
- [2] S. Samal, and P. K. Hota, "Design and analysis of solar PV-fuel cell and wind energy based microgrid system for power quality improvement," *Cogent Engineering*, vol. 4, no. 1, p. 1402453, 2017, doi: 10.1080/23311916.2017.1402453.
- [3] V. K. Remya, P. Parthiban, V. Ansal, and B. Chitti, "Dynamic voltage restorer (DVR) – A review," *Journal of Green Engineering*, vol. 8, no. 4, pp. 519–572, 2018, doi: 10.13052/jge1904-4720.844.
- [4] R. Jadeja, N. Bizon, T. Trivedi, A. Ved, and M. Chudasama, "Power quality issues and mitigation techniques in microgrid," *Microgrid architectures, control and protection methods*, pp. 719-748, 2020, doi: 10.1007/978-3-030-23723-3\_30.
- [5] G. Vijayshree and S. Sumathi, "Improvement of power quality using instantaneous reactive power theory for controlling shunt active filter," *International Conference on Circuits, Controls and Communications (CCUBE)*, 2021, pp. 1-6, doi: 10.1109/CCUBE53681.2021.9702742.
- [6] S. Devassy and B. Singh, "Design and performance analysis of three-phase solar PV integrated UPQC," *IEEE Transactions on Industry Applications*, vol. 54, no. 1, pp. 73-81, 2017, doi: 10.1109/ICPES.2016.7584022.
- [7] S. C. Devi, B. Singh, and S. Devassy, "Modified generalised integrator based control strategy for solar PV fed UPQC enabling power quality improvement," *IET Generation, Transmission and Distribution*, vol. 14, no. 16, pp. 3127-38, 2020, doi: 10.1049/iet-gtd.2019.1939.
- [8] K. Gaddala and P. S. Raju, "Optimal location of unified power quality conditioner in distribution system for power quality improvement," *International Journal of Electrical Power and Energy Systems*, vol 83, pp. 309-24, 2016, doi: 10.1108/JEDT-04-2019-0113.



- [9] N. Kalpana, "FACTS device for voltage regulation in microgrid applications," *International Research Journal of Engineering and Technology*, vol. 05, no. 11, pp. 01-04, 2018.
- [10] R. Pal and S. Gupta, "Topologies and control strategies implicated in dynamic voltage restorer (DVR) for power quality improvement," *Iranian Journal of Science and Technology, Transactions of Electrical Engineering*, vol. 44, no. 2, pp. 581-603, 2020, doi: 10.1007/s40998-019-00287-3.
- [11] M. Vishnuvardhan, "Power quality improvement analysis by using different control techniques," *Journal of Engineering Science*, vol. 11, no. 2, pp. 1-12, 2020.
- [12] S. Devassy and B. Singh, "Performance analysis of solar PV array and battery integrated unified power quality conditioner for microgrid systems," *IEEE Transactions on Industrial Electronics*, vol. 68, no. 5, pp. 4027-4035, 2021, doi: 10.1109/TIE.2020.2984439.
- [13] H. Bakir and A. A. Kulaksiz, "Modelling and voltage control of the solar-wind hybrid micro-grid with optimized STATCOM using GA and BFA," *Engineering Science and Technology, an International Journal*, vol. 23, no. 3, pp. 576-84, 2020, doi: 10.1016/j.jestch.2019.07.009.
- [14] G. Dileep, "A survey on smart grid technologies and applications," *Renewable Energy*, vol. 146 no. 19, pp. 2589–2625, 2020, doi: 10.1016/j.renene.2019.08.092.
- [15] M. A. Oumer and B. Pattanaik, "Interline dynamic voltage restoration (IDVR) in transmission line," *International Journal of MC Square Scientific Research*, vol. 11, no. 2, pp. 22-28, 2019.
- [16] S. N. Rao *et al.*, "Power quality improvement in renewable-energy-based microgrid clusters using fuzzy space vector PWM controlled inverter," *Sustainability*, vol. 14, no. 8, p. 4663, 2022, doi: 10.3390/su14084663.
- [17] P. Kandasamy, K. Chandrasekaran, R. Natarajan, and J. Selvaraj, "Deep CNN–LSTM-based DSTATCOM for power quality enhancement in microgrid," *Journal of Circuits, Systems and Computers*, vol. 31, no. 07, 2022, doi: 10.1142/S0218126622501304.
- [18] A. R. Singh, P. Ray, and S. R. Salkuti, "A novel approach for power quality improvement in microgrid," *Next Generation Smart Grids: Modeling, Control and Optimization*, pp. 313-332, 2022, doi: 10.1007/978-981-16-7794-6\_13.
- [19] M. A. Heidari, M. Nafar, and T. Niknam, "A novel sliding mode based UPQC controller for power quality improvement in microgrids," *Journal of Electrical Engineering and Technology*, vol. 17, no. 1, pp. 167-77, 2022, doi: 10.1007/s42835-021-00886-3.
- [20] N. Khosravi, S. Echalih, R. Baghbazadeh, Z. Hekss, R. Hassani and M. Messaoudi, "Enhancement of power quality issues for a hybrid AC/DC microgrid based on optimization methods," *IET Renewable Power Generation*, vol. 16, no. 8, pp. 1773-91, 2022, doi: 10.1049/rpg2.12476.
- [21] L. Nagarajan and M. Senthilkumar, "Power quality improvement in distribution system based on dynamic voltage restorer using rational energy transformative optimization algorithm," *Journal of Electrical Engineering and Technology*, vol. 17, no. 1, pp. 121-37, 2022, doi: 10.1007/s42835-021-00869-4.
- [22] S. Vijayalakshmi, R. Shenbagalakshmi, C. P. Kamalini, M. Marimuthu and R. Venugopal, "Power quality issues in smart grid/microgrid," *Planning of Hybrid Renewable Energy Systems, Electric Vehicles and Microgrid*, pp. 403-442, 2022, doi: 10.1007/978-981-19-0979-5\_17.
- [23] S. Choudhury, D. P. Acharya, and N. Nayak, "Power quality issues mitigation in an AC Microgrid through Bayesian regularization algorithm-trained artificial neural network," *Advances in Intelligent Computing and Communication*, pp. 145-154, 2022, doi: 10.1007/978-981-19-0825-5\_15.
- [24] B. N. Harish and U. Surendra, "A review on power quality issues in electric vehicle interfaced distribution system and mitigation techniques," *Indonesian Journal of Electrical Engineering and Computer Science*, vol. 25, no. 2, pp. 656-665, 2022, doi: 10.11591/ijeecs.v25.i2.pp656-665.
- [25] R. Cárdenas-Dobson, E. Espina, J. Llanos, C. Burgos-Mellado, G. Martínez-Gómez, and D. Sáez, "distributed control strategies for microgrids: An overview," *IEEE Access*, vol. 1, no. 1, pp. 1-37, 2020, doi: 10.1109/ACCESS.2020.3032378.
- [26] M. Paul, and D.V. Kumar, "Model Based Predictive Control Strategy for Grid-Connected Wind Energy System," *International journal of advances in signal and image sciences*, vol.8, n. 1, pp. 1–8, 2022, doi: https://doi.org/10.29284/ijasis.8.1.2022.1-8.
- [27] M. M. Ismail, M. Subbiah, and S. Chelliah, "Design of Pipelined Radix-2, 4 and 8 based multipath delay commutator (MDC) FFt," *Indian Journal of Public Health Research & Development*, vol. 9, no. 3, p. 765, 2018, doi: 10.5958/0976-5506.2018.00380.7

## BIOGRAPHIES OF AUTHORS



**Ms. Mythreyee Madhavan**    is currently pursuing her Ph.D. from Dr. M.G.R. Educational and Research Institute. She obtained her B.E from Annamalai University and MTech from Vellore Institute of Technology. Her specialization in PG is Energy systems. Her research interests include Smart Grid, Renewable Energy, Power quality simulation and optimization. He can be contacted at email: m.mythreyee@gmail.com.



**Dr. Nalini Anandan**    received her Ph.D. Degree from Dr. M.G.R. Educational & Research Institute. She obtained her B.E. and M.E. from Annamalai University. She Her specialization in PG is Power Systems. Her research interests include Smart Grid, Wide Area Monitoring and Control, Phasor Measurement Unit, Power System Simulation studies, and Optimization. She is presently working as Professor of Electrical and Electronics Engineering Department and Dean-University Library at Dr. MGR Educational and Research Institute, Chennai, Tamil Nadu, India. He can be contacted at email: nalini.eee@drmgrdu.ac.in.