

## Research On Android Intelligent Phones Controlling the Car to Run

Jinsong Song<sup>1</sup>, Zhenghua Xin<sup>\*2</sup>, Wei Ding<sup>3</sup>

<sup>1</sup>Suzhou radio and television, Shun He Road, the TV Lane, Suzhou TV emission, Suzhou City, China

<sup>2</sup>Department of Information Engineering, Suzhou University

<sup>3</sup>Department of Electrical Engineering, Suzhou University

Corresponding author, e-mail: begin0000@qq.com

### Abstract

*The system finished the android smart mobile phone to control the intelligent car to avoid the obstacles wirelessly based on the bluetooth communication protocol. The android system is popular. But researches on applying it in the wireless sensors are very few. This paper allowed the bluetooth-enabled android phones to communicate with sensors wirelessly through our designed software. The software is installed simply on the phones. The operator can run the software and touch the screen on the intelligent phones to drive the car. When he/she presses the front/the back/the left/the right on the LCD screen of the phones, the car can move forward/backward/the left or/the right. In addition, the gravity sensing of the smart telephone can also control the motion of the car wirelessly in the same way. The car itself can avoid the obstacle intelligently. The ultrasonic sensor can finish the rotation of the 180 degrees to detect the obstacle with the help of the steering gear. And the system also designed the PCB and made the hardware by ourself. The system has advantages of low-cost, convenience and feasibility.*

**Keywords:** android, bluetooth, ultrasonic, steering gear, PWM

**Copyright © 2013 Universitas Ahmad Dahlan. All rights reserved.**

### 1. Introduction

The technology of the bluetooth is applied in the communication of the wireless network. For example, in the [1], it is applied in the shared key based dynamic encryption scheme. The intelligent phones are popular, and people can browse the webpage. And they have been embedded in the android system which includes the bluetooth protocol stack more than 2.0. Because it requires low power, low cost and communicates with other devices embedded in the bluetooth module. Also it can be applied in a healthcare system using handheld mobile network [2]. But the paper [1] and [2] only uses the bluetooth technique. The Java applications of the intelligent systems can run on the intelligent phones to retrieve, store and analyze the information [3-5]. They are only concern about developing the software. The sensors are more and more widely used now [6]. In the [6], the ultrasonic controled the buzzer through the Zigbee network. [7] used the android-based devices. But it is not relative about the wireless communication. The paper [8-10] lays the emphasis on the embeded hardware design, wireless sensors network and the operating system. All in all, researches on both the bluetooth and the android system are few. This paper offered an solution of the application for the intelligent phones to control the wireless sensors from the hardware design to the software. The system will be applied widely.

The general design of the system includes two modules. One is how the intelligent car to avoid the obstacles automatically. The other is how the intelligent phones based on the android system to control the rotation of the car remotely.

### 2. The Hardware Design of the Intelligent Car System

The system consists of STC89C52 MCU, L298 motor drive circuit, power circuit, the ultrasonic module, the steering gear and the bluetooth module. The STC89C52 is selected as the control unit of the smart car. Because it is cheap. Then the extended system based on it cuts the cost but with powerful features. The ultrasonic sensor can measure the distance to help detect obstacles. And then the distance is processed by the microcontroller to control the

motor. The steering gear is used to control the ultrasonic module to roll in order to analyze the obstacle position. The bluetooth module can be connected to the microcontroller. The software is installed on any telephone based on android. It includes the bluetooth communication program. So the operator can control the car through the telephone.

**2.1. Car Models**

The motor of the car, some screws and copper cylinder are necessary to be assembled to be a car. But it must be controlled by the design and production of the circuit module. The smallest single-chip system is the most simple circuit to work. It includes a microcontroller, clock circuit, reset circuit. The circuit diagram is as follows.

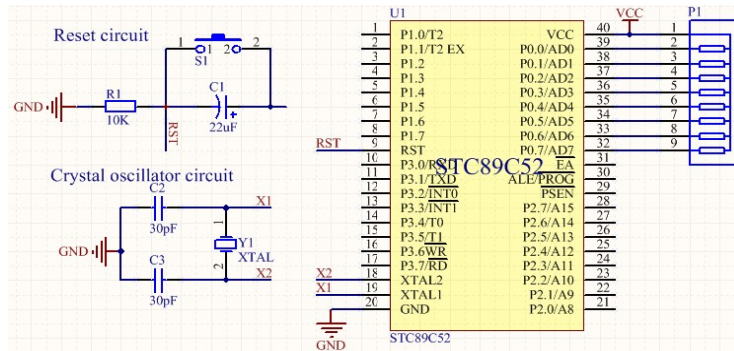

Figure 1. The Smallest Single-chip System

Then the downloading circuit has been designed for programming the single-chip as shown in Figure 1. The software STC-ISP can help download the program. The MAX232 serial communication uses the three-line linking way as shown in the Figure 2.

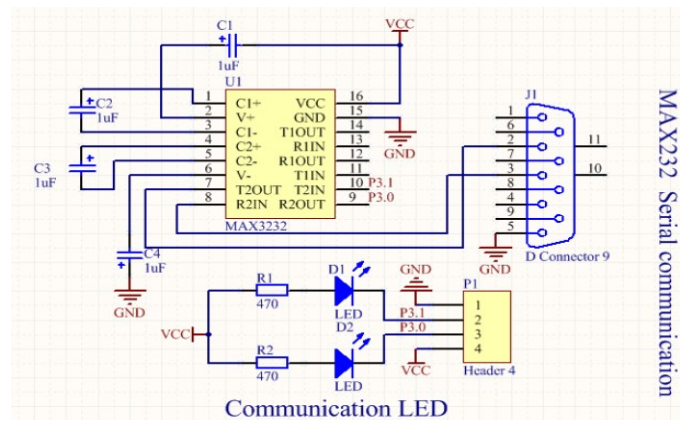

Figure 2. The Link of the MAX232 Serial

**2.2. The Circuit of the Power Supply**

The motor of the system requires a voltage of about 6V. But the microcontroller needs a 5V supply voltage. In the system, two 3.7V lithium batteries supply power to the motor. And the LM2940 voltage regulator can output 5V to the chip.

**2.3. The Motor Drive Circuit**

This ST's L298N is the main driver chip. It has a voltage as high as 46V and the instantaneous peak current up to 3A. The 15-pin package can be used. The L298N chip can

drive the two-phase stepper motors or four-phase stepper motor and drive two DC motors as shown in the Figure 3 and the Figure 4.

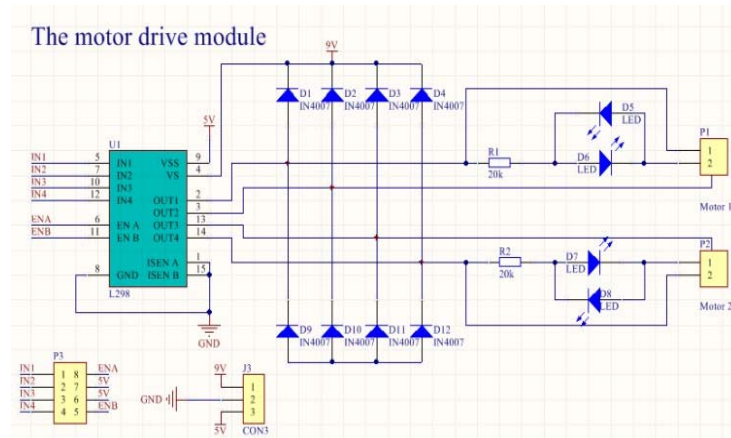

Figure 3. L298N Motor Drive Schematic

The output current of I/O port in the microcontroller is small. So the drive motor is very convenient, but it must not connect with the microcontroller directly. And it can drive the rotation way of the motor and also control the steering and speed of the motor. There is a table to explain how to use the L298 to control the DC motor.

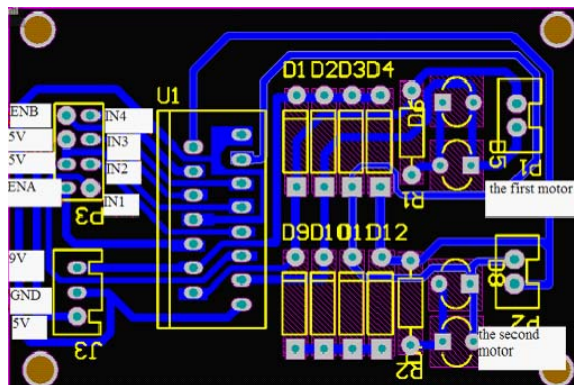

Figure 4. L298N Motor Drive PCB Map

Table 1. The Pins of the DC Motor

DC motor	IN1	IN2	IN3	IN4	ENA	ENB	rotation mode
The first motor	1	0	/	/	1	/	clockwise rotation
	0	1	/	/	1	/	anticlockwise rotation
	0	0	/	/	1	/	stop
The second motor	/	/	1	0	/	1	clockwise rotation
	/	/	0	1	/	1	anticlockwise rotation
	/	/	0	0	/	1	stop

The ENA and ENB are enabling ports of the L298. Only high level makes the L298 work. The pins IN1, IN2, IN3 and IN4 connects the pins of the microcontroller. They are defined as follows in the system.

```
# Define qianjin () P1 = 0xf5 // moving forward
# Define houtui () P1 = 0xfa // moving backward
# Define youzhuang () P1 = 0xf1 // turn to the right
# Define zuozhuang () P1 = 0xf4 // turn to the left
# Define tingzhi () P1 = 0x00 // stop
```

#### 2.4. The Ultrasonic Module

There are four pins. The VCC supplies the 5V voltage. The GND is the ground wire. The TRIG triggers to input the control signal. The ECHO outputs signals.

The program sets the 10uS pulse trigger signal through the I/O ports. The the interior of the ultrasonic module will issue eight 40kHz square wave and detect the echo signal automatically. Once the echo signal has been received, the pin ECHO output the high level. The pulse width of the echo signal is proportional to the measured distance. Thereby the time interval can be used to calculate the distance. The formula is as follows.

$$\text{Test distance} = (\text{the period of the time} * 340 \text{ m / s}) / 2 \quad (1)$$

There are some attentions, the time interval should be more than 60ms. The area of the measured object is not less than 0.5 square meters. And the plane should be smooth as much as possible. Or else the result is affected.

```
sbit Trig = P2 ^ 0; // ultrasonic transmitter end
sbit Echo = P3 ^ 2; // ultrasonic receiving end
void chaoshengbo () // ultrasonic
{Trig = 0;
delay_us (5);
Trig = 1;
delay_us (20); // control issued by the end 10us high
while (! Echo); // determine whether the received high level
TR1 = 1;
}
void ex_0 () interrupt 0
{ TR1 = 0;
th = TH1;
tl = TL1;
TH1 = 0;
TL1 = 0;
time = th * 256 + tl;
distance = time * 0.185;
if (distance <250.0) // in front of the judge 150ms there are no obstructions
{n = 0;
been = 0;
the delay_ms (100);
been = 1;}
else
n = 1; }
```

#### 2.5. Principles of Steering Gear

The ultrasonic sensor tests whether there are obstacles in the front. If no object, the intelligent car moves forward. Or else, the steering gear controls the ultrasonic sensor to turn left at some angle regularly. If there is the obstacle, and then it turns back. It controls the ultrasonic sensor to turn right at some angle. The program for the MCU determines how the steering gear works. The speed of steering gear without loading is 0.12 seconds/60 degrees or 0.13 seconds/60 degree when the power supply is 4.8V or 6.0V. The stall torque is 1.98kg•cm when the power supply is 4.8V. The control pulse cycle of the steering gear period is 20ms. The pulse width is ranging from 0.5ms to 2.5ms, respectively, corresponding to the rotation of -90 degrees to +90 degrees. In fact, it is the scheme of the PWM pulse width modulation. The steering gear only has three lines, voltage, grounding line and the signal line of controlling pulse width. The system set the P2.0 port of the microcontroller.

### 3. The Settings About the Communication of the Bluetooth

The system uses the slave HC-06 module. And the extended interfaces include the VCC, the GND, the TXD, the RXD and the reserve LED status output pin. The microcontroller can judge whether the devices of bluetooth connect or not. The KEY pin is invalid on the slave device. If the led is always lighting, the devices of the bluetooth have connected. The floor of the module is fixed the anti-reverse diode with the LDO of the 3.3V. The input voltage of the bluetooth is 3.6~6V. The unpaired current is about 30mA. The pairing current is 10mA. The input voltage is not more than 7V. The bluetooth module is shown in the Figure 5 and Figure 6.



Figure 5. The Chip of the Bluetooth Module

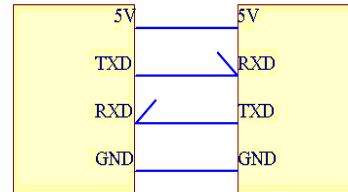

The bluetooth module various TTL level MCU / equipment

Figure 6. The Diagram of the Communication

The interface level is 3.3V and can be connected directly to the microcontroller without MAX232. The effective distance of the bluetooth module is 10 meters. The system uses full-duplex serial port. It supports 8 data bits, 1 stop bit, no parity communication format. The intelligent phones establish a Bluetooth connection through the AT command which sets the baud rate, name and passkey and saves parameters when the power is turned off. After the connection of the bluetooth, the transparent mode is switched automatically. The connection between the bluetooth module and the microcontroller.

The bluetooth module uses the serial port communication. The TX of the bluetooth module connects receiving end RX of the microcontroller. In the system, RX is the port P3.1. The receiving end RX of the bluetooth module links the TX of the microcontroller, P3.0. The direction of a serial communication transmission is divided into simplex, half-duplex and full-duplex. This system uses the last way. The way of the asynchronous serial communication is the way 0 and the way 1. This system selects the way 1. One frame of data includes 10 bits.

When the data is stored to SBUF register, the microcontroller starts to send data automatically from the beginning to the stop bit. When the stop bit is sent, the internal hardware sets 1 to TI and applies the interrupt to the CPU right now. Then the program of the interrupt service routine works.

The value of the REN is set 1. The receiver samples the pin level of the RXD at the speed of 16 times the baud rate. When the level of the RXD pin is detected negative transition, the start bit is valid. So the rest bits of the frame are received in order. When the start bit is shifted from the leftmost of the register, the control circuit completes the last shift. Until the value of the RI the SM2 is 0, the early received 8 data bits have been loaded into the SBUF. The ninth bit goes into RB8 and the value of RI is set 1. The interrupt works after requesting the CPU. Here is the specific procedure to explain how to make a phone with a bluetooth module to control the car.

```

init ();
while (1)
{ if (flag == 1) // receive serial data to determine which key is pressed
{switch (a)
{case 65: P1 = 0xf5; break; // send the A 1111 01 01 forward
case 66: P1 = 0xf1; break; // send the B 1111 0001 turn left
case 67: P1 = 0xf4; break; // send C 1111 0100 turn right
case 68: P1 = 0xfa; break; // send the D 1111 1010 Back
case 69: P1 = 0x00; break; // Send E stop command
default: break;
}}}

```

#### 4. The Results of the System

The sensors, the microcontroller are mainly integrated into the intelligent car as shown in the Figure 7. The interface of the software on the phone is shown in the Figure 8 and Figure 9. There are the main codes.

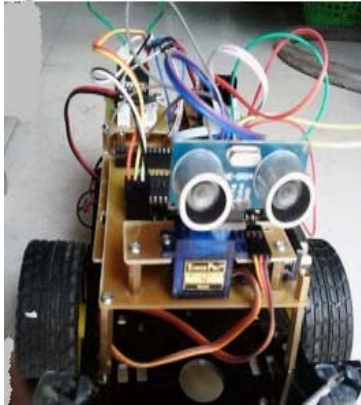

Figure 7. The Intelligent Car

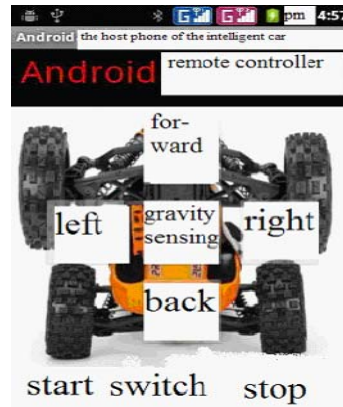

Figure 8. The Gravity Sensing Control

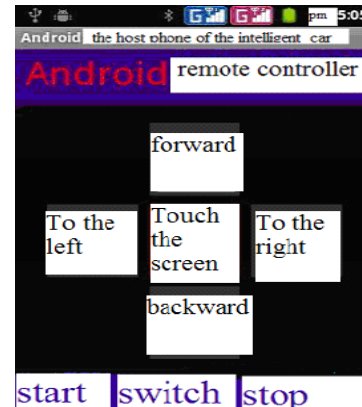

Figure 9. The Touching Screen Control

```

while (1){
the Tingzhi ();
chaoshengbo ();           // ultrasonic function
delay_ms (20);
if (n == 1)               // no obstacle is detected, the car go forward
{Qianjin ();
the delay_ms (100);
}
if (n == 0)               // trolley detected obstacle
{the Tingzhi ();         // trolley stop
n = 1;
hight_votage += 6;       // Servo turn left 90 °
the delay_ms (400);
chaoshengbo ();
delay_ms (20);
left = n;                // read the value of n paid to left, n = 0 left obstacle
n = 1;
hight_votage = 6;        // servos Go to the middle
the delay_ms (400);
hight_votage = 6;        // Servo Go to the right 90 °
the delay_ms (400);
chaoshengbo ();
delay_ms (20);
right = n;
hight_votage += 6;       // steering gear back to the middle
the delay_ms (400);
n = 1;                   // week scan is completed
if (right == 0 && left == 1) // there is an obstacle to the right
{zuozhuan ();
the delay_ms (450);
Qianjin ();
}
else if (right == 1 && left == 0) // left obstacle
{youzhuan ();
}
}

```

```

the delay_ms (450);
Qianjin ();
}
else // front, left, right, has obstacles, on the back
{houtui ();
the delay_ms (400);
youzhuan ();
the delay_ms (300);
Qianjin ();} }}

```

The software is programmed by java and runs on the android platform in the intelligent telephones [6, 7]. It finishes how to turn on bluetooth module on the phone and how to start the function of the gravity sensing. And it sets the parameters of the bluetooth communication according to the bluetooth protocol. The key is how to send the instruction of making the car move forward. At last, this software outputs the different ASCII codes to stand for four directions. As long as judging the ASCII code, the bluetooth on the car is able to control the specific operation. For example, it receives 65 from the intelligent phone through the wireless communication, analyzes it and then sends the command for moving forward to the microcontroller. The software can control the car using a mobile phone's gravity sensing by pressing in the middle of gravity sensing key to switch to the gravity sensing control functions. If the phone is tilted to the left/right/the front/the back, the car will turn to the left/right/the front/the back.

## 5. Conclusion

The system applies the android system to complete the automatic control for the remote car using the bluetooth technique. The ultrasonic sensor can rotate with the range of 180 degree with the drive of the steering gear. If the obstacle is detected, the ultrasonic will rotate a certain degree. Until there is no obstacle, the car will move according to the new detected direction. But there is the obstacle after the rotation of 180 degrees, the car will move backward and continue the detection. So the obstacle will be avoided successfully. This system overcame the problem of coding. The system can be widely applied in the industrial control, intelligent home and so on. It made the smart phones apply on wireless sensors. This is specific and not found in other papers.

## Acknowledgement

This paper are sponsored by the Research Open Platform of Suzhou University (Laboratory of Intelligent Information Processing, 2012YKF39). Quality project of Anhui Province (20101077, 2012jyxm545). The national students' innovation and entrepreneurship training projects, "The design and application of intelligent guiding dog system" (201210379006). The innovation training program projects for the Anhui College students, Coal Mine Personnel Positioning System based on the RFID (201310379083), The implementation of embeded alarms management system based on A900 (201310379023).

## References

- [1] Madhusudan Singh, Sang-Gon Lee, Dhananjay Singh, Shirshu Varma. Shared Key Based Dynamic Encryption Scheme for Secure Bluetooth Technology. *Advances in information Sciences and Service Sciences*. 2011; 3(8).
- [2] Kuang-Hao Lin. A Healthcare System Using Handheld Mobile Network, *Advances in information Sciences and Service Sciences*. 2012; 4(20).
- [3] Zhenhu Liang, Yinghua Wang, Shuaiting Wang, Longzhou Guan, Yingwei Li, Xiaoli Li. A Remote Electrocardiogram Monitoring System Based on Smart Phone Platform. *Advances in information Sciences and Service Sciences*. 2011; 3(11).
- [4] Hiroshi Ishiguro. Scientific Issues Concerning Androids. *The International Journal of Robotics Research*. 2007; 26(1): 105-117.
- [5] Liu, Yun, Zhang, Jiru, Gao Jian. Panoramic technique in the video monitoring system and implementation. *TELKOMNIKA Indonesian Journal of Electrical Engineering*. 2013; 11(1): 91-96.

- 
- [6] Xin Zhenghua, Lu Hongmei, Hu Liangyi, Zhou, Jing. The device design of driving cars astern based on the wireless sensor networks node. *Advanced Materials Research*. 2012: 542-543: 989-992.
- [7] Mantoro, Teddy, Zakariya, Andri. Securing e-mail communication using hybrid cryptosystem on android-based mobile devices. *TELKOMNIKA Indonesian Journal of Electrical Engineering*. 2012; 10(4): 827-834.
- [8] Zhenghua Xin, Hong Li, Liangyi Hu. The Research on CC2530 Nodes Communicating with Each Other Based on Wireless. *TELKOMNIKA Indonesian Journal of Electrical Engineering*. 2013; 11(1): 430-435.
- [9] Zhenghua Xin, Yongliang Guo, Liangyi Hu. Research on the Implementation of Porting uC/OS-II on the STM32F103 chip. *TELKOMNIKA Indonesian Journal of Electrical Engineering*. 2013; 11(7): 3897-3904.
- [10] He Liu, Yadong Wang, Lei Wang. A Low-Cost Remote Healthcare Monitor System Based on Embedded Server. *TELKOMNIKA Indonesian Journal of Electrical Engineering*. 2013; 11(4): 1750-1756.