

Bandwidth enhancement of ultra-wideband monopole antenna designed with v-shaped defected ground structure

Lee Yee Hui¹, Dayang Azra Awang Mat¹, Dyg Norkhairunnisa Abang Zaidel¹,
Kismet anak Hong Ping¹, Shafrida binti Sahrani Shahrani²

¹Department of Electrical and Electronics Engineering, Faculty of Engineering, University Malaysia Sarawak (UNIMAS), Samarahan, Malaysia

²Research Fellow, Institute of IR4.0, Aras 1, Akademia Siber Teknopolis, Universiti Kebangsaan Malaysia, Bandar Baru Bangi, Malaysia

Article Info

Article history:

Received Jul 22, 2021

Revised May 25, 2022

Accepted Jun 10, 2022

Keywords:

Bandwidth enhancement
Defected ground structures
Monopole antenna
Rogers RO4003C
U&V-shaped

ABSTRACT

This paper discusses the design of a monopole antenna with various types of defected ground structures (DGS) for ultra-wideband (UWB) applications. The various types of DGSs are designed and acted as the ground layer of the antenna. The bandwidth of each design is then compared with and without the existence of DGS. Conventional monopole antenna has a bandwidth of 88.6% and operates in the frequency range of 3.1 to 8 GHz. According to the simulation results, the bandwidth of the monopole antenna with V-shaped DGS was the highest, which was at 133.3% (2.98-14.9 GHz), as compared to other types of DGS. The efficiency was between 30 to 64%, with a peak realized gain of 5.3 dB. The V-shaped DGS is then fabricated on a Rogers RO4003C substrate with a relative permittivity, ϵ_r , of 3.38 and a dimension of 29.86×39.03×0.81 mm. The antenna is measured using R&S network analyzer and the results were 3-8.5 GHz and 95.4% of BW, which signified the increased performance of the antenna.

This is an open access article under the [CC BY-SA](https://creativecommons.org/licenses/by-sa/4.0/) license.



Corresponding Author:

Dayang Azra binti Awang Mat
Department of Electrical and Electronics Engineering, Faculty of Engineering
Universiti Malaysia Sarawak (UNIMAS)
Sarawak, Malaysia
Email: amdazra@unimas.my

1. INTRODUCTION

Nowadays, the antenna represents the key component in wireless communication and microwave imaging applications. Compact, easy to fabricate, low profile and low cost are the requirements of antennas for future communication applications and microstrip monopole antenna fulfills these requirement [1], [2]. The main aim of the current research is to propose a design for a small high-performance antenna. Various approaches have been taken by previous researchers, such as notches and slots [2]–[8], tuning stub [8], [9], electromagnetic bandgap (EBG) [10]–[12], magneto-dielectric substrate [13], dielectric substrates with high permittivity [14] and defected ground structure (DGS) [15].

In this research, the focus is on the DGS. DGS can be defined as the region of any shape that is etched off from the ground plane. Electrical current flow distribution is affected by the design of the ground plane and causes excitation and propagation of an electromagnetic wave, which is manipulated by passing the current through the substrate [16]. As compared to other techniques such as EBG, DGS can be easily applied to microwave circuits and could increase the accuracy with just its basic structures [17]. The advantage of DGS is that the slow-wave effect can be achieved easily by using only one or a few DGS structures. This results in

the reduction of the circuit size [18], [19]. The slow-wave effect can reduce the velocity of the transmission line's group or increase its group latency to compress microwave design with slow-wave structures [20].

Current research has revealed that the presence of Y-shaped DGS improved the isolation and impedance bandwidth of the multiple-input and multiple-output (MIMO) antenna system, which was developed in a compact space [21]. DGS has also led to an improvement in the antenna's impedance performance [1], [15], [22], [23]. Size reduction and resonance frequency shifting of microstrip patch antenna were achieved by using a DGS consisting of concentric rings and a rectangular slot [18], [24]–[26]. Aside from bandwidth enhancement, the implementation of DGS with rectangular and triangle slots improved the cross-polarized suppression and gain of the antenna [27].

DGS is used to change the transmission line characteristics by disturbing the ground plane current distribution towards the antenna [28]. Thus, the resonance frequency for this equipment can be predicted. For the improvement of the antenna performance, the defect's shape can be modified from a basic to a complex shape. Various DGS geometries have been described, such as slot, spiral, H-shaped, concentric ring [24], U and V-shaped [29], split ring resonator (SRR), meander lines [19], fractals and dumbbell-shaped [26], which includes square heads, arrowheads, circular heads, U-heads, and others geometries [30]. Changes in the area of the slot will directly change the property of the effective inductance and its capacitance, although it is made of the same substrate. The decrement of the slot area leads to the increment of effective inductance and as a result, the effective capacitance will decrease and the resonance frequency will increase [28].

In this paper, the design of a monopole antenna with various types of DGSs for ultra-wideband (UWB) applications is presented and discussed. This work determines the appropriate DGS for UWB monopole antenna by analyzing the performance of six different shapes of DGS for the same monopole antenna based on their return loss value, S_{11} (dB), from simulation results. The operating frequency used for electromagnetic simulation tool, computer simulation technology (CST) is from 2.98 GHz to 14.9 GHz. The proposed antenna is fabricated and measured with an R&S vector network analyzer.

2. METHOD

2.1. Antenna design

A monopole antenna is one-half of a dipole antenna with an omnidirectional radiation pattern. It was first invented by radio pioneer Guglielmo Marconi in 1895 and patented in 1896 [31]. In this study, the monopole antenna is designed as shown in Figure 1. As shown in Figure 1(a) front view, Figure 1(b) side view and Figure 1(c) rear view of the proposed antenna and its dimensions and parameters are listed in Table 1. The proposed monopole antenna design is selected due to its attractive features such as lightweight, ease of fabrication, large bandwidth and radiation properties. The substrate used to fabricate this antenna was Rogers RO4003C with a thickness of 0.813 mm and a relative permittivity of 3.38. To estimate the lower band-edge frequency of printed monopole antenna, the antenna was designed according to the cylindrical monopole antenna formulation. The relationship between one-half the major axis A , one-half the minor axis B , length L and radius r of the cylindrical monopole antenna is given by Equation (1) for the printed elliptical monopole antenna (PEMA) [32].

$$L = 2B, r = \frac{A}{4} \quad (1)$$

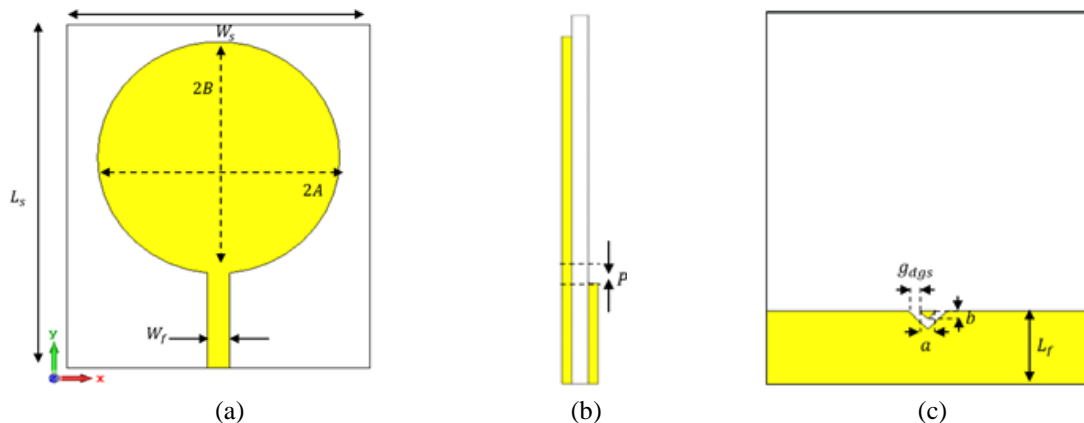

Figure 1. Proposed antenna (a) front, (b) side, and (c) back view

Table 1. Proposed antenna parameters

Parameters	Values (mm)
A	12
B	10.9
L_s	40
W_s	30
g_{dgs}	1.05
a	0.78
b	0.825

2.2. Design of DGS

Various types of DGSs, as shown in Figures 2 and 3, are implemented to the existing monopole antenna design to observe their effect on the performance of the antenna. Figure 2 (a) shows the square type dumbbell, Figure 2(b), H-shape dumbbell, Figure 2(c), arrow-headed dumbbell and Figure 2(d) the circular type dumbbell. Besides that, Figure 3(a) indicates curved U-shaped and Figure 3 (b) is V-shaped type DGS. Based on the classification of DGS geometry [17], [30], U, V, and dumbbell shapes are considered in this paper. The dumbbell shape and its variations, which includes H-shape, arrow-headed and circular-headed are selected. Figure 3 shows the design of curved U-shaped and V-shaped DGSs. Table 2 summarizes the parameters of all types of DGSs shown in Figures 2 and 3. The yellow regions are the conductive part (copper part) of the antenna’s ground plane, whereas the white area the etched-out region.

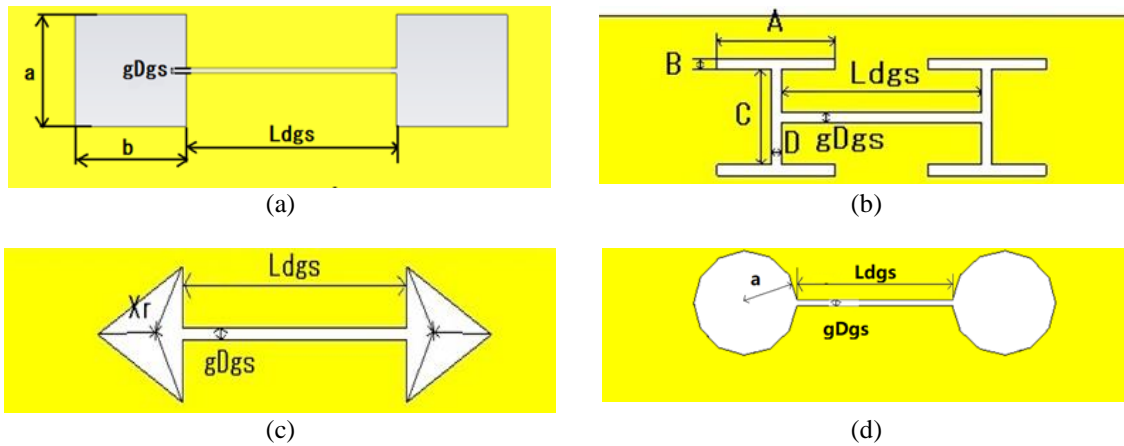

Figure 2. Dumbbell design and its variations (a) square, (b) H-shape, (c) arrow-headed and (d) circular

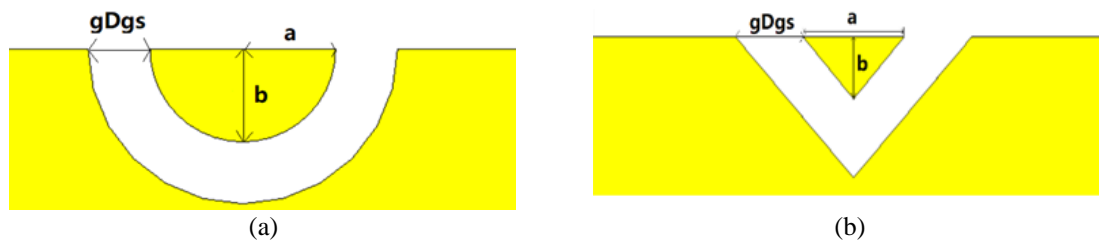

Figure 3. The design of (a) curved U-shaped and (b) V-shaped DGSs

Table 2. Parameters of DGS

		Types of DGSs					
	Square dumbbell DGS	H-shaped DGS	Arrow-headed dumbbell DGS	Circular dumbbell DGS	Curved U-shaped DGS	V-shaped DGS	
a	0.5mm	A 0.9mm	X_r 0.64mm	X_r 0.5mm	a 0.78mm	a 0.78mm	
b	0.5mm	B 0.1mm	g_{Dgs} 0.1mm	g_{Dgs} 0.1mm	b 0.825mm	b 0.825mm	
g_{Dgs}	0.035mm	C 1.12mm	L_{dgs} 1.95mm	L_{dgs} 1.95mm	g_{Dgs} 1.05mm	g_{Dgs} 1.05mm	
L_{dgs}	0.813mm	D 0.1mm					
		g_{Dgs} 0.035mm					
		L_{dgs} 0.813mm					

3. RESULTS AND DISCUSSION

The results are presented and discussed in this section. It can be categorized as the variation of DGS's position and shapes. From the perspective of microstrip excitation, the variation in the location and geometry of DGS affected the performance of the antenna.

3.1. Position of DGS

The analysis of the effect of DGS's positioning is done based on the coordinates of the DGS on the ground plane of the monopole antenna, as shown in Figure 4. The return loss characteristics, S_{11} (dB), is simulated at various DGS positions along the X and Y axes and the results are presented in Figure 5 and Figure 6. The simulation results are presented in absolute values, in which the X and Y values are either positive or negative. It shows that the S_{11} is more affected by the variation of the DGS's position along the Y-axis and the most significant impact is observed when the DGS is positioned near the antenna, as shown in Figure 6. Table 3 summarizes the results of impedance bandwidth at various positions of DGS on the ground plane of the antenna. Table 3 shows the variation of S_{11} (dB) depending on the DGS's position around the edge of the ground near the antenna and below the transmission line. The antenna bandwidth has been significantly improved by 133.52% to the coordinate (0,0), compared to 88.59% of the conventional antenna.

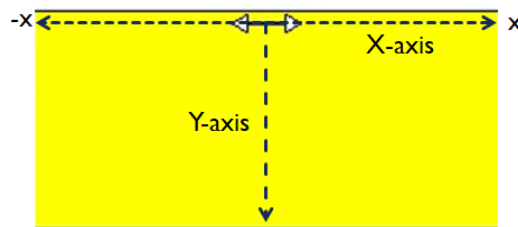

Figure 4. The variation of DGS's position on the ground plane of the monopole antenna

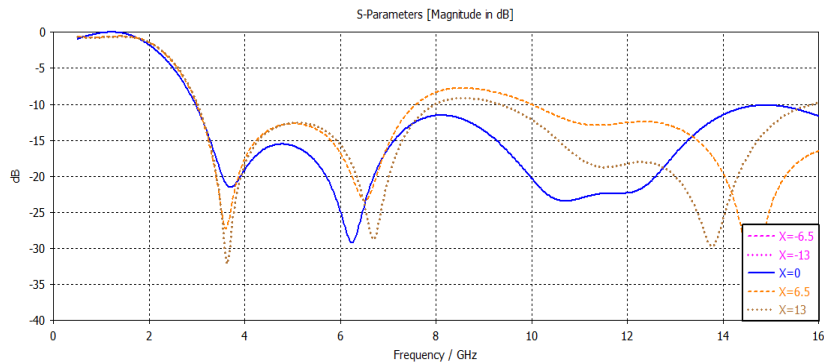

Figure 5. Return loss characteristic, S_{11} (dB), based on the positioning of the DGS along the X-axis

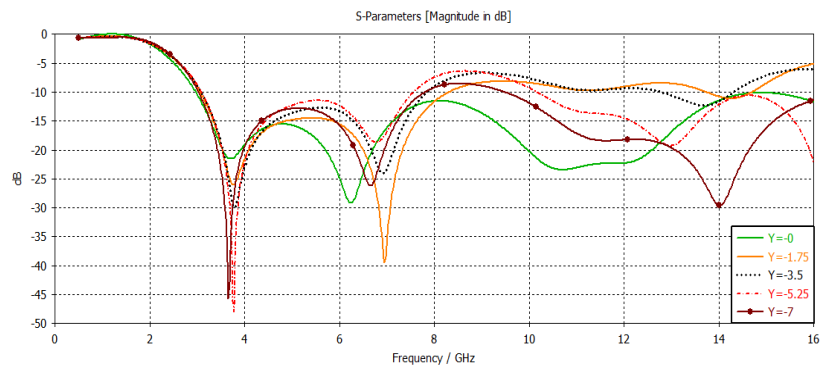

Figure 6. Return loss characteristic, S_{11} (dB), based on the positioning of the DGS along the Y-axis

Table 3. A summary of impedance bandwidth results for various X and Y-coordinates of DGS on the antenna

X-coordinate	-13.00	-6.50	0.00	6.50	13.00
Y-coordinate	f_L f_H BW	f_L f_H BW	f_L f_H BW	f_L f_H BW	f_L f_H BW
0.00	3.018.0090.63	0.007.5886.62	9714.9133.53	0.007.5886.63	0.017.9890.4
-1.75	3.037.9289.33	0.027.9289.63	068.3192.3	3.027.9289.63	0.017.9289.8
-3.50	3.027.9389.73	0.027.9489.83	087.8587.3	3.027.9389.73	0.017.9490.0
-5.25	3.027.9489.83	0.027.9489.83	097.5683.9	3.027.9589.93	0.017.9490.0
-7.00	3.027.9289.63	0.027.9389.73	037.8188.2	3.027.9389.73	0.027.9289.6

3.2. Shape of DGS

The return loss characteristics, S_{11} (dB), comparison are made between the various dumbbell shapes of the DGS and the results are shown in Figure 7. It is observed that the triangular dumbbell DGS is the most suitable choice for monopole antenna since it exhibited the broadest bandwidth among other dumbbell shapes. A comparison of S_{11} (dB) is also made between the triangular dumbbell-shaped, U-shaped and V-shaped DGSs, as well as the conventional antenna without DGS on the ground plane, which results are shown in Figure 8. As can be seen in Figure 8, the various DGSs resulted in improved antenna performance, with the U and V-shaped DGSs providing the best results. As compared to U-shaped DGS, the V-shaped DGS is the best DGS in this case, with simulated impedance BW of 133.33% (2.98–14.90 GHz) (defined by 10 dB). Table 4 summarizes the return loss characteristics, S_{11} (dB), of various shapes of DGS.

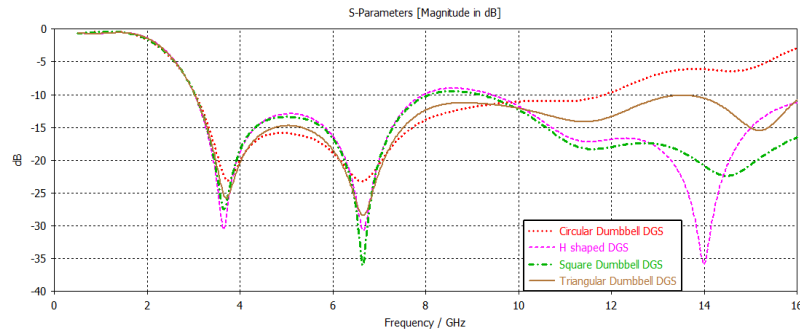

Figure 7. Comparison of return loss characteristics, S_{11} (dB), between various types of DGS

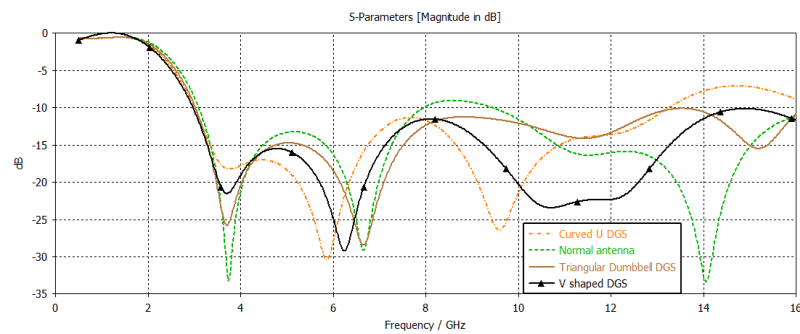

Figure 8. Comparison of return loss characteristics, S_{11} (dB), between the triangular dumbbell-shaped, U-shaped and V-shaped DGSs and conventional antenna without DGS

Table 4. Comparison between various shapes of DGSs on the ground plane

Type of DGS	f_L	f_H	BW	return loss(dB)
Normal antenna without DGS	3.10	8.03	88.59	-33.10
Square dumbbell	3.03	8.08	90.91	-35.70
Circular dumbbell	3.04	11.85	118.25	-23.10
Arrow headed dumbbell	3.03	13.20	125.32	-28.20
H-shape	3.02	7.96	89.98	-30.40
curved U-shaped	3.00	13.25	126.15	-30.30
V-shaped	2.98	14.90	133.33	-29.20
Type of DGS	f_L	f_H	BW	return loss(dB)

3.3. Simulated radiation pattern, gain and efficiency

Figures 9 and 10 demonstrate the simulated radiation patterns of the proposed monopole antenna with V-shaped DGS for the frequency at 4 and 6 GHz respectively. The radiation patterns behaved as omnidirectional and are stable across the entire passband. Figure 11 and 12 illustrate the simulated realized gain and efficiency of the monopole antenna respectively. The gain of the monopole antenna shows more than 1 dB over the UWB operating band. The gain of the monopole antenna gradually increased towards the upper frequencies for the entire bandwidth of UWB (3.1–10.6 GHz). Across the total frequency spectrum, the simulated efficiency is between 30 and 64%, where the latter is the maximum value reached within the frequency spectrum.

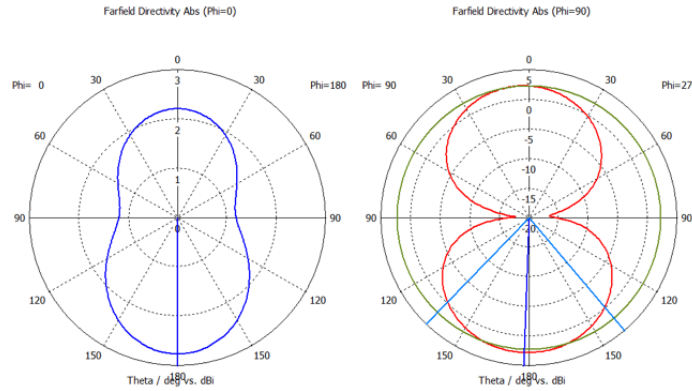

Figure 9. The E-plane and H-plane of the monopole antenna at frequency, $f = 4$ GHz

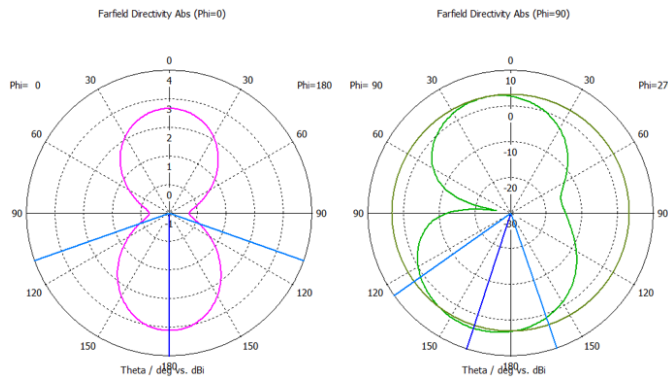

Figure 10. The E-plane and H-plane of the monopole antenna at frequency, $f = 6$ GHz

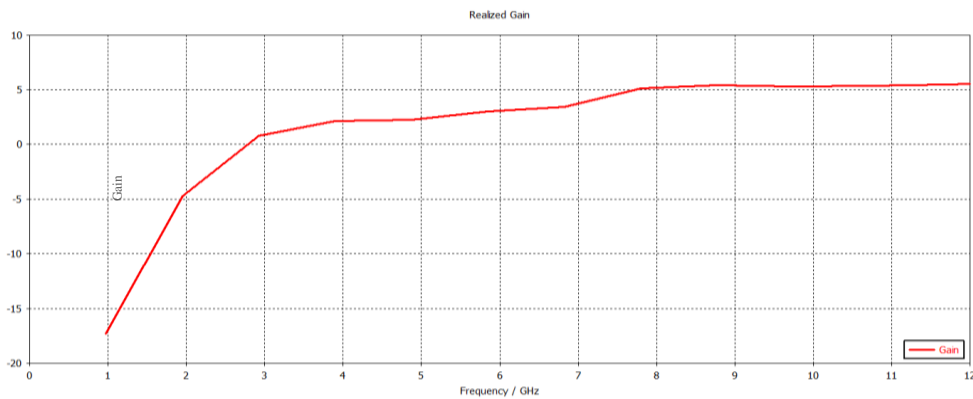

Figure 11. Simulated realized gain of the monopole antenna with V-shaped DGS

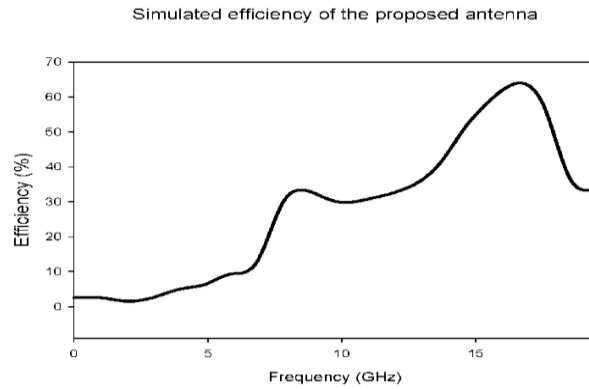

Figure 12. Simulated efficiency of the monopole antenna with V-shaped DGS

4. MEASUREMENT RESULTS

The proposed monopole antenna, depicted in Figure 13, is fabricated using Rogers RO4003C as substrate. The dimension of the fabricated antenna is 29.86×39.03×0.81 mm. Figure 13(a) shows the length and Figure 13(b) the width of the proposed antenna.

The measurement results are collected using an R&S vector network analyzer (VNA). The S_{11} (dB) obtained from the simulation and measurement are compared and illustrated in Figure 14. The measurement results could only be performed up to 8 GHz due to the limitation of the operational frequency range of the equipment available in the laboratory. Nevertheless, the measured and simulated S_{11} (dB) of the antenna is still below 10 dB throughout the 8.5 GHz frequency range.

Based on Figure 14, it is observed that the measured bandwidth is from 2.95 to 8.5 GHz. The pattern of the measured result is similar to that of the simulated result but then shifted upward. The antenna could operate from 2.95 to 8.5 GHz. This proves that the measured result is similar to the simulation result and the difference may be due to the fabrication procedures.



Figure 13. The dimension of the fabricated antenna (a) length and (b) width

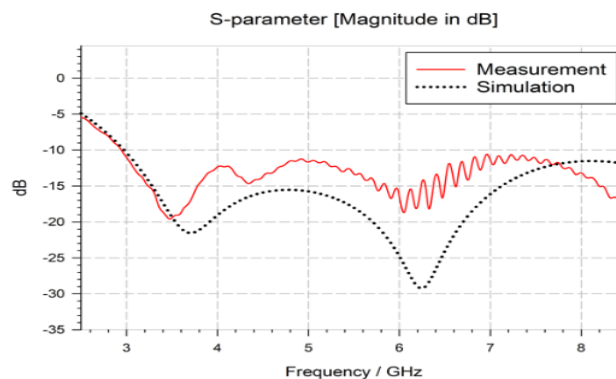

Figure 14. Simulated and measured return loss, S_{11} (dB), for the proposed monopole antenna with V-shaped DGS

5. COMPARISON WITH SIMILAR WORK

Three antennas with ultra-wide bandwidths and similar applications that are published in similar works were compared to the proposed antenna of this study. The proposed antenna with a V-shaped DGS is simple and compact, with the border of the bandwidth that covers the entire UWB band and it fulfilled the size reduction requirement. Based on Table 5, the proposed antenna delivered better performance in terms of bandwidth and dimension than the antennas that were reported in the literature.

Table 5. Comparison with others monopole antenna with DGS

Ref. No	BW(GHz)	Dimension(mm ³)	Ref. No
[6]	3–10	55×40×1.6	Planar circular disc monopole antenna
[15]	2.33–14.3	38×48×1.6	Monopole circular patch with dumb slot
[33]	0.115–2.90	48.3×43.7×0.8	Back-to-back triangular shaped patch with meander-line T-shape divider
[34]	3.18–11.50	40×40×1.52	Rectangular monopole with two slits and a notch
This work	2.98–14.9	29.86×39.03×0.81	Monopole antenna with V-shaped DGS

6. CONCLUSION

A monopole antenna with various types of DGSs had been simulated and discussed in this paper. The antenna with V-shaped DGS and a dimension of 29.86×39.03×0.81 mm possessed good monopole radiation properties and exhibited 95.4% of BW as compared to the conventional monopole antenna. The V-shaped DGS looked very promising for utilization with a frequency of more than 2.98 GHz. As a result of its compact design and low-cost fabrication, the proposed monopole antenna is an excellent candidate for UWB applications.

ACKNOWLEDGEMENTS

The authors acknowledged the financial support from the Ministry of Higher Education Malaysia through Fundamental Research Grant Scheme for Research Acculturation of Early Career Researchers (FRGS-RACER) RACER/1/2019/TK04/UNIMAS//1.



REFERENCES

- [1] D. Fitsum, D. Mali, and M. Ismail, "Bandwidth enhancement of rectangular microstrip patch antenna using defected ground structure," *Indonesian Journal of Electrical Engineering and Computer Science*, vol. 3, no. 2, p. 428, Aug. 2016, doi: 10.11591/ijeecs.v3.i2.pp428-434.
- [2] M. El Bakkali, M. El Bekkali, G. S. Gaba, J. M. Guerrero, L. Kansal, and M. Masud, "Fully integrated high gain s-band triangular slot antenna for cubeSat communications," *Electronics*, vol. 10, no. 2, p. 156, Jan. 2021, doi: 10.3390/electronics10020156.
- [3] X. K. Bi, X. Zhang, S. W. Wong, S. H. Guo, and T. Yuan, "Design of notched-wideband bandpass filters with reconfigurable bandwidth based on terminated cross-shaped resonators," *IEEE Access*, vol. 8, 2020, doi: 10.1109/ACCESS.2020.2975379.
- [4] A. R. Celik, M. B. Kurt, and S. Helhel, "Design of an elliptical planar monopole antenna for using in radar-based and ultra-wideband microwave imaging system," *Int. Res. J. Eng. Technol.*, vol. 04, no. 11, pp. 1978–1983, 2017.
- [5] S. Singhal and A. K. Singh, "CPW-fed octagonal super-wideband fractal antenna with defected ground structure," *IET Microwaves, Antennas Propag.*, vol. 11, no. 3, pp. 370–377, Feb. 2017, doi: 10.1049/iet-map.2016.0110.
- [6] A. R. Celik and M. B. Kurt, "Development of an ultra-wideband, stable and high-directive monopole disc antenna for radar-based microwave imaging of breast cancer," *J. Microw. Power Electromagn. Energy*, vol. 52, no. 2, pp. 75–93, Apr. 2018, doi: 10.1080/08327823.2018.1458692.
- [7] M. Solapure and S. Bhujade, "Design and analysis of monopole antenna for single and multiband applications," in *2017 International Conference on Intelligent Sustainable Systems (ICISS)*, Dec. 2017, pp. 786–790. doi: 10.1109/ISS1.2017.8389284.
- [8] A. Othman, N. I. S. Shaari, A. M. Zobilah, N. A. Shairi, and Z. Zakaria, "Design of compact ultra wideband antenna for microwave medical imaging application," *Indones. J. Electr. Eng. Comput. Sci.*, vol. 15, no. 3, p. 1197, Sep. 2019, doi: 10.11591/ijeecs.v15.i3.pp1197-1202.
- [9] Z. A. Dayo, Q. Cao, Y. Wang, P. Soothar, B. Muneer, and B. S. Chowdhry, "A compact broadband high gain antenna using slotted inverted omega shape ground plane and tuning stub loaded radiator," *Wirel. Pers. Commun.*, vol. 113, no. 1, pp. 499–518, Jul. 2020, doi: 10.1007/s11277-020-07227-z.
- [10] M. A. Trimukhe and B. G. Hogade, "A compact ultra-wideband (UWB) antenna with dual band-notched characteristic based on small-size electromagnetic bandgap (EBG) structure," *Lect. Notes Data Eng. Commun. Technol.*, vol. 36, pp. 75–84, 2020, doi: 10.1007/978-981-15-1002-1_9.
- [11] A. A. Althuwayb, M. Alibakhshikenari, B. S. Virdee, P. Shukla, and E. Limiti, "Realizing UWB antenna array with dual and wide rejection bands using metamaterial and electromagnetic bandgaps techniques," *Micromachines*, vol. 12, no. 3, p. 269, Mar. 2021, doi: 10.3390/mi12030269.
- [12] M. Abu, S. Adlina Md Ali, N. Radiah Mohamad, and M. Muhamad, "Flexible dual band dipole antenna with electromagnetic band gap," *Indones. J. Electr. Eng. Comput. Sci.*, vol. 5, no. 3, p. 593, Mar. 2017, doi: 10.11591/ijeecs.v5.i3.pp593-598.
- [13] A. Kaban, A. Shariha, A.-C. Tarot, J.-L. Mattei, D. Souriou, and P. Queffelec, "Impact of magneto-dielectric materials on the miniaturization of UWB monopole antennas," in *2018 International Workshop on Antenna Technology (iWAT)*, Mar. 2018, pp. 1–3. doi: 10.1109/IWAT.2018.8379224.
- [14] M.-A. Boujemaa, R. Herzi, F. Choubani, and A. Gharsallah, "UWB antipodal vivaldi antenna with higher radiation performances using metamaterials," *Appl. Phys. A*, vol. 124, no. 10, p. 714, Oct. 2018, doi: 10.1007/s00339-018-2132-1.



- [15] D. Gopi, A. R. Vadaboyina, and J. R. K. K. Dabbakuti, "DGS based monopole circular-shaped patch antenna for UWB applications," *SN Appl. Sci.*, vol. 3, no. 2, p. 198, Feb. 2021, doi: 10.1007/s42452-020-04123-w.
- [16] A. K. Arya, M. V. Kartikeyan, and A. Patnaik, "Defected ground structure in the perspective of microstrip antennas: a review," *Frequenz*, vol. 64, no. 5–6, Jan. 2010, doi: 10.1515/FREQ.2010.64.5-6.79.
- [17] L. H. Weng, Y.-C. Guo, X.-W. Shi, and X.-Q. Chen, "An overview on defected ground structure," *Prog. Electromagn. Res. B*, vol. 7, pp. 173–189, 2008, doi: 10.2528/PIERB08031401.
- [18] N. N. Tawfeeq, "Size reduction and gain enhancement of a microstrip antenna using partially defected ground structure and circular/cross slots," *Int. J. Electr. Comput. Eng.*, vol. 7, no. 2, p. 894, Apr. 2017, doi: 10.11591/ijece.v7i2.pp894-898.
- [19] Y. Rao, H. J. Qian, B. Yang, R. Gomez-Garcia, and X. Luo, "Dual-band bandpass filter and filtering power divider with ultra-wide upper stopband using hybrid microstrip/DGS dual-resonance cells," *IEEE Access*, vol. 8, pp. 23624–23637, 2020, doi: 10.1109/ACCESS.2020.2970209.
- [20] H. Jin, K. Wang, J. Guo, S. Ding, and K. Wu, "Slow-wave effect of substrate integrated waveguide patterned with microstrip polyline," *IEEE Trans. Microw. Theory Tech.*, vol. 64, no. 6, pp. 1717–1726, Jun. 2016, doi: 10.1109/TMTT.2016.2559479.
- [21] J. Zhu, B. Feng, B. Peng, L. Deng, and S. Li, "A dual notched band MIMO slot antenna system with Y-shaped defected ground structure for UWB applications," *Microw. Opt. Technol. Lett.*, vol. 58, no. 3, pp. 626–630, Mar. 2016, doi: 10.1002/mop.29632.
- [22] K. Li, T. Dong, and Z. Xia, "Wideband printed wide-slot antenna with fork-shaped stub," *Electronics*, vol. 8, no. 3, p. 347, Mar. 2019, doi: 10.3390/electronics8030347.
- [23] J. A. Ansari, S. Verma, M. K. Verma, and N. Agrawal, "A novel wide band microstrip-line-fed antenna with defected ground for CP operation," *Prog. Electromagn. Res. C*, vol. 58, pp. 169–181, 2015, doi: 10.2528/PIERC15052305.
- [24] Jing Pei, An-Guo Wang, Shun Gao, and Wen Leng, "Miniaturized triple-band antenna with a defected ground plane for WLAN/WiMAX applications," *IEEE Antennas Wirel. Propag. Lett.*, vol. 10, 2011, doi: 10.1109/LAWP.2011.2140090.
- [25] R. Er-rebyiy, J. Zbitou, A. Tajmouati, M. Latrach, A. Errkik, and L. El Abdellaoui, "A new design of a miniature microstrip patch antenna using Defected Ground Structure DGS," in *2017 International Conference on Wireless Technologies, Embedded and Intelligent Systems (WITS)*, Apr. 2017, pp. 1–4, doi: 10.1109/WITS.2017.7934598.
- [26] M. A. Salamin, W. Ali, and A. Zugari, "Design and analysis of a miniaturized band-notched planar antenna incorporating a joint DMS and DGS band-rejection technique for UWB applications," *Microsyst. Technol.*, vol. 25, no. 9, pp. 3375–3385, Sep. 2019, doi: 10.1007/s00542-018-4183-9.
- [27] M. K. Khandelwal, B. K. Kanaujia, S. Dwari, S. Kumar, and A. K. Gautam, "Bandwidth enhancement and cross-polarization suppression in ultrawideband microstrip antenna with defected ground plane," *Microw. Opt. Technol. Lett.*, vol. 56, no. 9, pp. 2141–2146, Sep. 2014, doi: 10.1002/mop.28499.
- [28] M. K. Khandelwal, B. K. Kanaujia, and S. Kumar, "Defected ground structure: fundamentals, analysis, and applications in modern wireless trends," *Int. J. Antennas Propag.*, vol. 2017, pp. 1–22, 2017, doi: 10.1155/2017/2018527.
- [29] M. Elhabchi, M. N. Srifi, and R. Touahni, "A tri-band-notched UWB planar monopole antenna using DGS and semi arc-shaped slot for WIMAX/WLAN/X-band rejection," *Prog. Electromagn. Res. Lett.*, vol. 70, 2017, doi: 10.2528/PIERL17050813.
- [30] M. Dhanashri, S. Salgare, M. Shamala, and R. Mahadik, "A review of defected ground structure for microstrip antennas," *Int. Res. J. Eng. Technol.*, vol. 2, no. 6, pp. 150–154, 2015, [Online]. Available: www.irjet.net
- [31] K. D. Wong, *Fundamentals of Wireless Communication Engineering Technologies*. 2011. doi: 10.1002/9781118121115.
- [32] C. A. Balanis, "Antenna theory; analysis and design," in *Proceedings of the IEEE*, 2008, vol. 72, no. 7, pp. 989–990, doi: 10.1109/proc.1984.12959.
- [33] M. Alibakhshikenari *et al.*, "Wideband printed monopole antenna for application in wireless communication systems," *IET Microwaves, Antennas Propag.*, vol. 12, no. 7, pp. 1222–1230, Jun. 2018, doi: 10.1049/iet-map.2017.0894.
- [34] M. N. Hasan, S. Chu, and S. Bashir, "A DGS monopole antenna loaded with u-shape stub for UWB MIMO applications," *Microw. Opt. Technol. Lett.*, vol. 61, no. 9, pp. 2141–2149, Sep. 2019, doi: 10.1002/mop.31877.

BIOGRAPHIES OF AUTHORS





Lee Yee Hui    is currently a Master student in University Malaysia Sarawak starting 2019. She has her degree in Electronic and Telecommunication Engineering, University Malaysia Sarawak and graduated in 2019. She is doing her research project in antenna and filter design. She can be contacted at email: doreenlyh95@gmail.com.





Ts. Dr. Dayang Azra binti Awang Mat    is a Senior Lecturer in Faculty of Engineering, University Malaysia Sarawak from 2006 until now. She graduated from Kyushu University Japan, in 2014 with Doctor of Engineering (in RF and millimeter-wave design). She received her MEng. (Computer and Communication) in 2006 at Universiti Kebangsaan Malaysia and degree in BEng. (Hons) Electronic and Telecommunication at Universiti Malaysia Sarawak. She is expert in mobile and wireless communication, antenna and filter design, RF both in microwave and millimeter-wave. She can be contacted at email: amdazra@unimas.my.



Dr. Dyg Norkhairunnisa Abang Zaidel    received the B.Sc. degree in computer science from the University of Hartford, USA, the M.Sc. degree in computing from The University of Sheffield, U.K., and the Ph.D. degree in soft computing from The University of Sheffield, U.K. She used to hold several administrative posts with the School of Computing, Universiti Teknologi Malaysia (UTM), Johor, from 2007 to 2018, including the Head of Department, the Deputy Dean of Postgraduate Studies, and the Deputy Dean of Academic. She was also the Director of the Big Data Centre (Centre of Excellence), UTM, from 2019 to February 2020. She is currently a Professor with the Department of Data Science and the Dean of Undergraduates, Universiti Malaysia Kelantan (UMK). She has supervised and co-supervised more than 20 masters and 20 Ph.D. students. She has authored or coauthored more than 150 publications: 80 proceedings and 57 journals, with 19 H-index and more than 1000 citations. Her research interests include soft computing, machine learning, and intelligent systems. She can be contacted at email: sitizaiton@umk.edu.my.



Associate Professor Ir Ts Dr Kismet Anak Hong Ping    is an Associate Professor at the Department of Electrical & Electronic Engineering, Faculty of Engineering. He received his BEng. (Hons) (Electronics and Telecommunications) from Universiti Malaysia Sarawak, MSc in Digital Communication Systems from Loughborough University, United Kingdom and PhD in Systems Science from Nagasaki University, Japan in 1998, 2000 and 2009, respectively. His research activities are mainly focused on developing microwave image processing algorithms for medical diagnostics and antenna design. His interests include applications of microwave engineering in biomedical imaging, through-the-wall imaging (TWI), and Non-Destructive Testing (NDT). He is a Professional Engineer registered with the Board of Engineers Malaysia (BEM), a Professional Technologist registered with the Malaysia Board of Technologist (MBOT), Member of The Institution of Engineers Malaysia (M.I.E.M), Senior Member of The Institution of Electrical & Electronic Engineering (SMIEEE) and Certified Energy Manager in ASEAN Energy Management Scheme (AEMS). He can be contacted at email: hpkismet@unimas.my.



Ts. Dr. Shafrida binti Sahrani Shahrani    is currently a Research Fellow at Institute of IR4.0, Universiti Kebangsaan Malaysia, 43600 Bangi, Selangor. Her expertise are computational electromagnetics, wave scattering and propagation, microwave imaging and system integration which deals with the development of new electromagnetic modeling, techniques and/or system. She can be contacted at email: shafrida@ukm.edu.my.