

Comparative evaluation of optical amplifiers in passive optical access networks

Bimogo Joseph Armel¹, Essiben Dikoundou Jean-Francois^{1,2}, Ihonock Eyembe Luc²

¹Department of Electrical Engineering, Advanced Teachers' Training College for Technical Education, University of Douala, Douala, Cameroon

²Technology and Applied Sciences Laboratory, University of Douala, Douala, Cameroon

Article Info

Article history:

Received Feb 21, 2021

Revised Jun 18, 2022

Accepted Jul 8, 2022

Keywords:

Amplifier
Modulation
Optical
Telecommunication
Transmission

ABSTRACT

In this paper, the parameters of optical amplifiers are evaluated using numerical methods with the Optisystem software. The main objective of this evaluation is the implementation of an optical telecommunication architecture, able to push back the current limits, due to a more and more restricted bandwidth following a demand which does not stop growing. We start from a study of the classical architecture of an optical telecommunication network with an external modulation provided by the Mach-Zehnder modulator, the non return to zero (NRZ) coding, a pseudo random bit generator and a continuous wave (CW) laser diode of frequency 193.1 THz. The results obtained show a transmission possibility at 30.8 dBm and an output power of 25 dBm (316 mW) with an electrical rate signal to noise (SNR) and optical rate signal to noise (OSNR) beyond 34 dBm. The successive integration of the different amplifiers will improve these results with a gain of more than 10 dBm and also provide a better signal quality.

This is an open access article under the [CC BY-SA](https://creativecommons.org/licenses/by-sa/4.0/) license.



Corresponding Author:

Bimogo Joseph Armel
Department of Electrical Engineering, Advanced Teachers' Training College for Technical Education
University of Douala
Carrefour Ange Raphaël, Douala, Cameroon
Email: barelbimogo@yahoo.com

1. INTRODUCTION

Access network implementation strategies have undergone major revolutions over the last ten years. Indeed, the old design of access networks exclusively reserved for telephone transmissions, with coaxial cable as the only transmission medium, seems to be over in favour of the integration of optical fiber. The rapid evolution of services provided through the internet has largely contributed to the emergence of optical transmissions. Today, the volume of traffic generated by digital data has considerably exceeded that of analogue data; it is now possible to achieve average transmissions of around 120 Gbit/s in access and trans-oceanic networks [1].

This revolution requires changes in the principles of network design, management and control. Current transmission systems should be capable of enabling telecom operators to meet the growing demands for both capacity and service time. Indeed, between 2012 and 2019, the demand for bandwidth grew at a rate of nearly 51%; it is clear that this rate is higher nowadays, especially with the advent of video, which, according to CISCO, accounts for nearly 70% of traffic [2], [3]. The large-scale deployment of access networks now represents a new challenge for telecommunication operators, given the advantages offered by optical transmissions such as very low losses, high bandwidth and immunity to electromagnetic interference [4], [5].

Unfortunately, the linear and non-linear effects inherent in optical fibers that the signal faces during its propagation contribute strongly to the impairment of these services. In developing countries as well as in metropolitan areas, a massive deployment of optical fiber is observed. In the evolution of access networks, the management of population growth issues and the constant desire of telecom operators to provide modern services are the main objectives that telecom engineers must take into account. In this context, China is now a leader in the deployment of fiber to the x (FTTX) with nearly 60% of the population subscribing [6].

Indeed, population growth inevitably leads to an increasing demand for bandwidth. In addition to this growing demand, there are increasing demands on the quality and quantity of the service provided in the short and long term by the consumer. The development of new generations of mobile telephony can be seen as sufficient proof. We have moved very quickly from first to fourth generation networks. However, the fifth (5G) and sixth (6G) generations are still exclusively reserved for countries with highly developed telecommunications technology [7], [8].

In the current context, the integration of optical amplifiers could improve the performance of PONs in view of their properties and characteristics. For a long time reserved for trans-oceanic networks because of its rather high pump power, recent scientific research in optical telecommunications networks confirms that it is now possible to integrate the Raman amplifier into any type of network, with the aim of increasing its capacity without modifying the existing infrastructure [9], [10]. Faced with the new challenges mentioned above, current and future access networks must inevitably be equipped with optical amplifiers to improve their gain, noise figure, output power and bandwidth. In other words, they need to enhance their advanced modulation technique, to increase spectral efficiency. The Raman amplifier could be a very interesting solution in passive optical networks (PONs). A recent comparative study on the performance of optical amplifiers places it ahead of the erbium doped fiber amplifier (EDFA), justified by the fact that the current network design based solely on EDFAs is not able to support high level modulation formats capable of withstanding noise in the face of increased capacity requirements [11], [12].

Several techniques using EDFAs have shown their limitations. Although they are able to extend the bandwidth, improve the gain, their dependence on the conventional (C) band is a significant drawback for access networks and the technique generates bandwidth gaps [13]. In addition, the versatility of the Raman amplifier, its gain flatness and its resistance to noise make it an interesting asset in access networks. Of course, optical amplifiers in today's networks need to combine not only amplification characteristics in terms of gain, noise figure and saturation power, but also a large bandwidth gap that allows additional channels to be sent.

In other words, current PONs need to integrate advanced modulation formats to increase their spectral efficiency, making them capable of using the wavelength division multiplexing (WDM) infrastructures with the objective of addressing bandwidth and channel spacing constraints. WDM, like all other modern techniques, requires specific performance from optical amplifiers [14], [15]. Among these amplifiers, the performance of Ramans has now supplanted the semiconductor optical amplifiers (SOAs) and EDFAs. However, the performance of the Raman optical amplifier combined with that of the EDFA can enhance the optical transmission capabilities in any type of network; their ability to provide gain over the entire bandwidth is an attractive asset in optical transmissions. All that is required is to choose a pumping type that is suitable for the wavelength [16].

Given the fact that the signal propagation in the fiber can be limited due to linear and non-linear effects such as dispersion phenomena, microbending losses [17], [18]. Our main objective in this paper is the characterization of an optical telecommunication architecture by integrating optical amplifiers. This is achieved by optimizing parameters such as quality factor, noise and bit error rate [19]. All this while highlighting the low cost of deployment and taking into account industrial constraints and the studies carried out by the IEEE.802.3 group, which demonstrate the possibility of transmission with a data rate of between 10 and 50 Gbits/s in accordance with the standardization project for access networks associated with the studies carried out long before by FSN (full service access network) [19], [20].

2. RESEARCH METHOD

We will highlight our experimental scheme based on the main components of an optical transmission synoptic. These include the emission, transmission and reception parts. These include the emission, transmission and reception parts [21].

2.1. Modulations

In optical telecommunications, various modulation techniques are associated with optoelectronic components or semiconductors for shaping the signal before it is propagated in the optical fiber. Two optoelectronic components are commonly used: laser diodes and light-emitting diodes. One of the main reasons for this choice is their small size, which allows them to fit easily into the core of the optical fiber. As

for modulation techniques, two formats are most often used: NRZ and RZ (return to zero). For our simulations, we will use the Mach Zehnder modulator, NRZ coding, a pseudo-random bit generator and a CW continuous wave laser diode with 193.1THz frequency and 100GHz transmission spacing. The choice of NRZ coding is justified by the fact that NRZ is an interesting asset when it is necessary to minimize the spectral broadening "chirp" caused by the positive dispersion in the optical fibers, unlike RZ which offers a high spectral broadening [22], [23]. Our system operates in the third transmission window, around 40 channels.

2.2. Transmission channel

Our transmission channel will be the optical fiber associated with the preamplifiers whose role will be to shape the signal at the output of the modulator. Once the initial results have been obtained, we will associate the optical amplifiers (SOA, EDFA and Raman) with this channel in order to carry out a comparative evaluation. The optical fiber chosen for our work is the G652 A, whose characteristics are given in Table 1.

Table 1. Characteristics of the G652 A optical fiber [24]

Type of fiber	Core diameter and cladding	Loss	Respective attenuation	Service wavelength	application
G652 A	120/8-10 nm	0	1310-0.5 dB 1550-0.4 dB	1360-1460 nm	10 Gbit/s au 40 km (Ethernet)

2.3. Reception

Reception will be provided by the PIN photodiode. PINs have a weakly doped intrinsic zone between the type region and the P-type region. Inverse polarized, they emit a current proportional to the incident optical power. The APDs react to the intrusion into the PN region by triggering an electron avalanche. From a minimum of incident photons, an electric current can be created. Compared to PIN, APDs have better performance in the 2.5 to 10 Gbit/s range. However, their cost is higher. For very high data rates around 40 Gbit/s, PINs outperform APDs [25].

2.4. Evaluation tools

Digital transmission quality is simple to evaluate; it is sufficient to compare the sequence of symbols sent with the sequence of symbols received, and to count the errors (number of times a "0" is detected for a "1" sent or vice versa). The bite error rate (*BER*) is the ratio of the number of errors to the number of bits transmitted during the measurement [26]. In order to measure the overall quality of a system of wavelength multiplexed channels, the *BER* of all channels must be measured. If only one of several channels has errors, the *BER* of the overall system is close to that of the channel with errors. The quality factor (*Q*) in a transmission system is characterized mathematically by (1).

$$Q = \frac{I_1 - I_0}{\sigma_1 - \sigma_2} \quad (1)$$

Q is usually expressed in dB using (2):

$$Q_{dB} = 20 \log_{10}(Q), \quad (2)$$

where I_1 and I_0 are the mean values of the photocurrents of symbols 1 and 0, σ_1 and σ_2 are the square roots of the variances of the probability densities of symbols 1 and 0. *BER* and *Q* are united by (3):

$$BER = \frac{1}{2} \left(\operatorname{erf} \left(\frac{Q}{\sqrt{2}} \right) \right) \quad (3)$$

where *erf* is the complementary error function.

The best way to judge the quality of a signal is to observe its eye diagram, which represents the synchronous superposition of any binary symbol in the transmitted sequence [27]. The signal is degraded or of poor quality if the time jitter in the eye diagram converges to a single point and is completely enclosed, a slight noise is observed. The value of the quality factor thus tends towards 0 and error-free signal detection becomes difficult. This diagram is an effective visual means of judging the quality of the signal within the limits of the response of the photodiode and the oscilloscope used. In optical telecommunication, the criteria for better transmission are defined from a *BER* lower than 10^{-10} and a quality factor higher than 6.4 [28].

2.5. Operating design

These configurations will be simulated with the Optisystem software, whose particularity is to propose components with virtual behaviour very close to the real thing [21]. Figure 1 shows the diagram of our transmission system. The three main part namely the modulation, the transmission channel (optical fiber) and the demodulation are represented. In addition to these, we can observe the measuring devices that allowed us to capture and read our results.

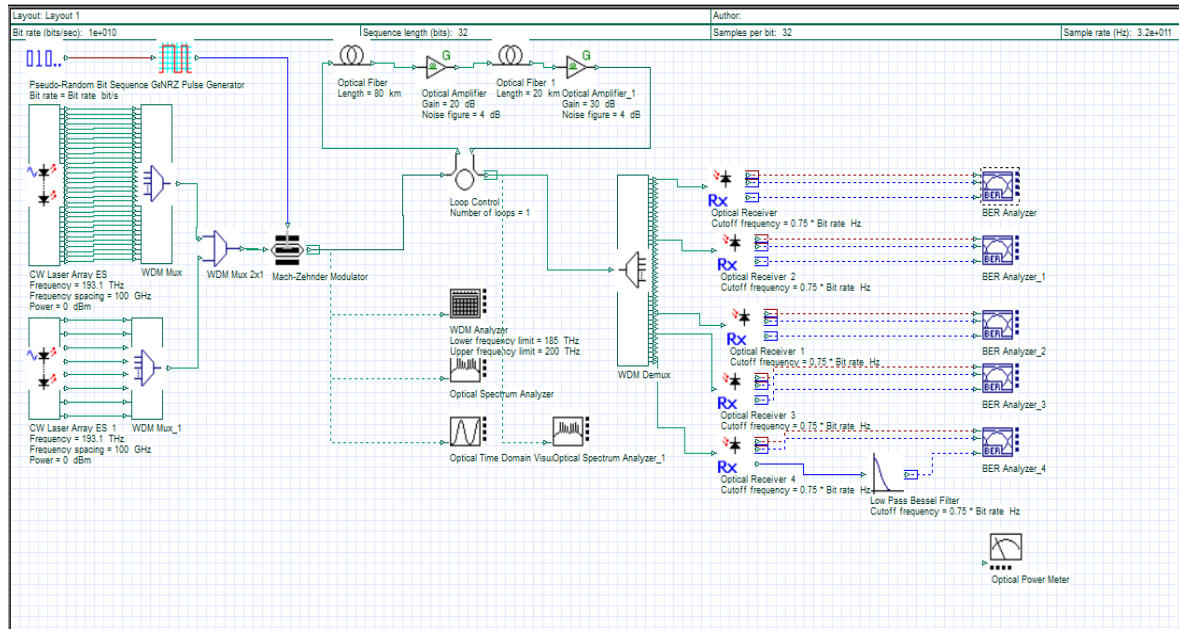

Figure 1. Developed diagrams of a classical architecture

3. RESULTS AND DISCUSSION

3.1. Simulation parameters

Table 2 shows us the different numerical parameters of our simulations. We can find the different wavelength values, the respective gain values at these wavelengths, the noise evaluation and the input and output power values. The numerical values that we present are an integral part of the transmission system that we wish to analyze.

Table 2. Numerical values of the different modelling parameters

Wavelength (nm)	Gain (dB)	Noise figure (dB)	Input signal (dB)	Input SNR (dB)	Input OSNR (dB)	Input noise (dB)	Output signal (dB)
1552,5244	29,97	-100	-3.2510	26.490	28.546	-29.74.4	26.72
1551,7208	30,02	-100	-3.2528	26.076	28.645	-29.453	26.76
1550,918	30,10	-100	-3.2556	26.026	28.132	-31.345	26.74
1550,1161	29,98	-100	-3.2521	22.195	28.065	-30.657	26.75
1549,315	29,98	-100	-3.2511	22.235	28.923	-26.165	26.77
1547,7116	30,05	-100	-3.2523	22.924	28.132	-26.986	26.75
1546,1189	30,03	-100	-3.2576	22.134	28.267	-26.324	26.54
1546,3229	29,07	-100	-3.2504	22.323	28.784	-26.150	26.38
1544,5243	29,92	-100	-3.2542	23.987	28.113	-26.066	26.50
1543,7305	29,30	-100	-3.2713	23.307	24.321	-26.146	26.49
1542,936	29,41	-100	-3.2776	23.132	24.231	-26.118	26.50
1542,1423	30,08	-100	-3.2743	23.234	24.502	-26.164	26.48
1541,3414	30,07	-100	-3.2712	23.132	24.410	-27.376	26,74
1540,5675	30,14	-100	-3.2741	23.231	24.670	-25.123	26.89
1539,7661	29,16	-100	-3.2742	23.168	24.768	-30.197	26.56
1524,1101	29,96	-100	-3.2723	23.132	24.879	-30.543	26.73

3.2. Noise assessments

A transmission is always subject to noise, which is a source of annoyance during signal propagation. This noise can be generated by the electrical components used on the one hand and by the optical components on the other. The direct consequences of noise in the signal are numerous. Figure 2 shows the evolution of the electrical and optical noise encountered in our architecture. In Figure 2, the SNR and OSNR signals are shown. These signals refer to the electrical and optical noise, respectively, present at the input and output of the transmission system.

At the input, the SNR is of an initial value approximately equal to 26 dB, due to imperfections related to the electrical components of the transmission chain. Once the signal is introduced into the fiber, a peak of 28.5 dB is reached at a wavelength of 15.21 nm. This noise will decrease during transmission as a function of wavelength and has regular peaks at certain times due to linear and non-linear effects. The most infinite SNR value is 21.88 dB at a wavelength λ of 1538 nm which is very close to 1550 nm. After this wavelength, a sawtooth-like evolution is observed, but below the maximum value. The interval $1521.76 < \lambda < 1550.56$ can thus be defined as the SNR concentration interval in the signal propagation in the third transmission window. The SNR will stabilize at the output around 32 dB, which is the final noise value in a transmission chain. This explains and justifies some of the key points of an optical transmission system and at the same time shows the importance of fiber transmission since it provides a noise that is substantially stable and therefore easy to manage in the support of classical optical transmission architectures even though it is high. So if we consider only the SNR we can conclude that the latter is constant at the output of the system and at any wavelength value.

The OSNR representing the optical noise is fixed at 29, 4 dB, this value will know a brutal fall on a value λ of 15, 22 dB. Its minimal value is reached around four respective wavelengths of 1527, 1531, 1538 and 1543 nm that is to say an OSNR of 23 dB. The choice of the optical transmitters is thus important for an optical transmission because the value of the OSNR depends on it to avoid a degradation of the signal being able to deteriorate the quality of transmission. Once again, the stability of this signal at the output of the transmission chain can be observed, even though it is higher than the input, with a value of 34.5 dB compared with 30 dB at the input. The results expressed in this figure also indicate the importance of the optical noise compared to the electrical noise. For comparison, it can be seen that the OSNR is higher than the SNR in an optical transmission system. With regard to the efficiency of optical transmission, we note a certain stability in the results obtained at the outputs, namely 33 dB for any wavelength for the SNR and 36 for the OSNR

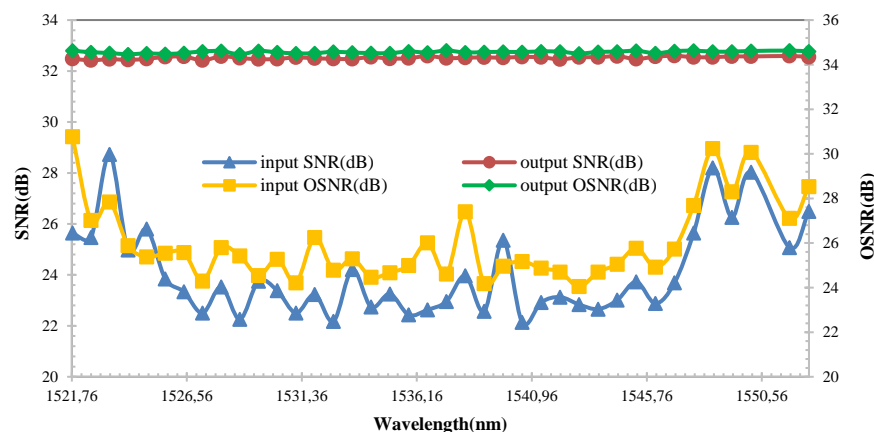

Figure 2. Evaluation of input and output noise as a function of wavelength

3.3. Input power, output power and signal gain

The evolution of the gain, input and output power, are shown in Figure 3, with values initially fixed at 29.8 dB for the input power or 800 mW as a function of wavelength. The respective curves are shown in blue for the gain, in green for the output power and in red for the input power. We can observe the evolution of parameters such as gain and output power with respect to wavelength. The different variations in gain versus wavelength show a maximum peak of 30.2 dB, at a wavelength λ equal to 1544 nm, and a minimum of 29.8 close to 1545.77 nm. These different variations reflect the disturbances to which the signal is subjected to and also the important role of the optical amplifiers in the transmission lines. Apart from the observed peak, there is no great difference between the different gains values observed. At the output, a high

power of about 30.8 dB is obtained, which is stable throughout the third window. The Table 3 is more explanatory on the different variations of Gain, OSNR and SNR. The absorption phenomena is the main of the difference in gain observed around the wavelengths included in this windows.

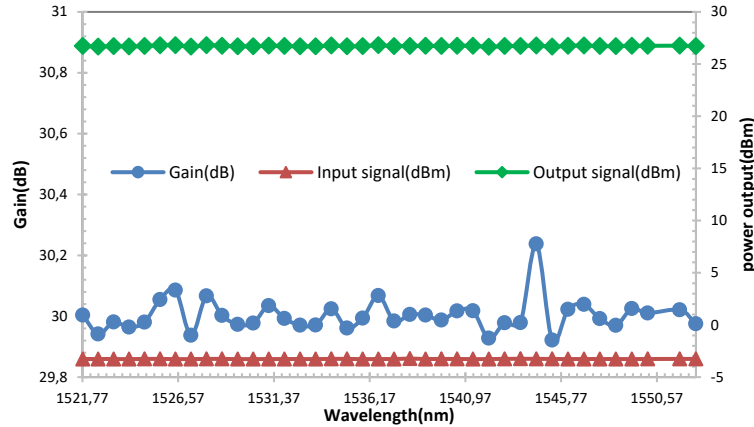

Figure 3. Gain and output power as a function of wavelength

Table 3. Summary of OSNR, SNR and gain in the transmission system

λ et signal	1521,76	1526,56	1531,26	1536,16	1540,96	1545,76	1550,26
OSNR	30	24,2	26	26	25	26	30
SNR	25,9	22,3	23	22,4	22	24	27
Gain	30	29,8	30	30,01	30,2	29,8	30

3.4. Quality factor Q and bit error rate

Figure 4 show the evolution of the quality factor and the bit error rate in a channel in relation to the bit rate. The blue curve represents the quality factor as indicated in the legend, while the bit error rate is shown in red. For a maximum data rate of 10 Gbit/s per channel, the Q factor evolves in a decreasing manner, more precisely from 10 to 50. This evolution reflects the dependence of the quality factor on the bit rate. The higher the data rate D, the more the quality factor Q tends towards 0. In this system it is in the range [10 50] for a data rate D between [0 10]. In the literature review Q is between 3 and 10; this result confirms a better transmission for a data rate of 10 Gbit/s. As for the bit error rate, it is represented in red; constant around the bit rates of 1 and 5 Gbit/s, this curve experiences a sharp and decreasing drop around 5 and 7 Gbit/s before increasing to the value of 2.2E-23. This evolution can thus be summarized in three intervals with different values. So, for $1 < D < 5$, $Q=47$, for $5 < D < 10$ we have Q which tends towards 10. As for the evolution of the BER, it can be summarized in the following boxes: $-3E-24 < BER < 2.2E-23$ for a data rate between 0 and 10 Gbits.

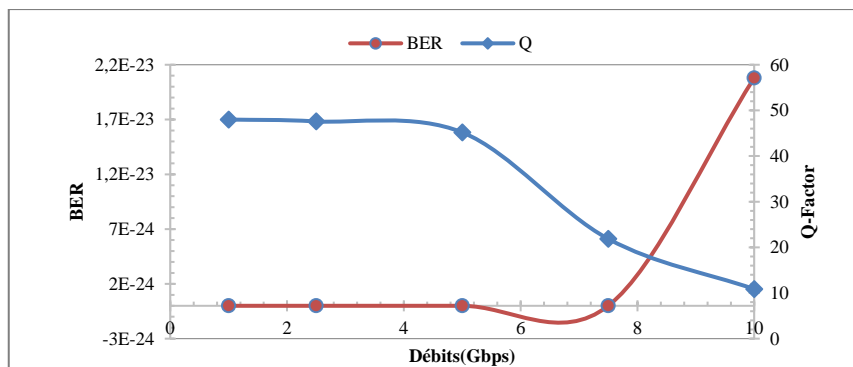

Figure 4. Evolution of the quality factor and BER in relation to the flow rate

3.5. Gain evolution after integration of SOA, EDFA, Raman

Figure 5 shows the evolution of the gain in the different wavelengths. It is composed of three Figure 5(a), Figure 5(b), and Figure 5(c) which represent this evolution respectively in SOA, EDFA and Raman. In Figure 5(a), it can be seen that the gain tends to be uniform at all wavelengths; this rate is higher at short propagation distances. At 10 Km the gain provided by the SOA amplifier is much lower than 0 dB. This result confirms previous scientific work that opposes the integration of SOA in optical telecommunications. Indeed, although it offers a substantially stable gain over the third window, the value remains very low to support new services. In Figure 5(b), we have the gain as a function of the EDFA. This gain varies with the wavelengths, hence the stability problem. However, the value of the gain is high and better for a propagation between 10 and 70 Km, since it is higher than 0 contrary to 80 Km where we observe a negative value. The possibility of high gain is one of the advantages of the EDFA, but the fact that it can be combined with shaping amplifiers is very cumbersome and makes it unusable for very long distance links. In Figure 5(c), the Raman amplifier offers better gain flatness for any wavelength regardless of the propagation distance. Its main problem remains a rather low gain but by optimizing the pump configurations and its power, we have the possibility to obtain a rather high gain that can compete with EDFAs. However, it is still very efficient at very long distances because of its gain flatness.

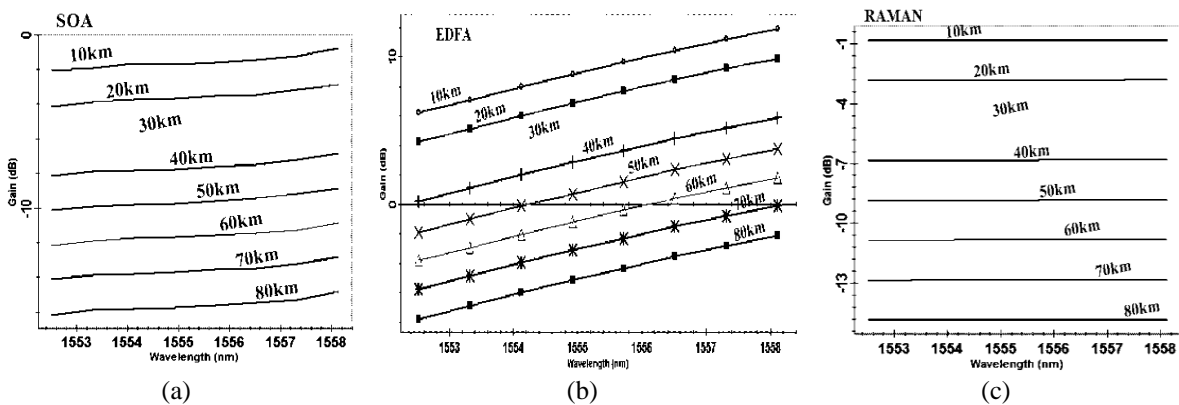

Figure 5. Evolution of the respective gain as a function of wavelength in (a) SOA, (b) EDFA, and (c) Raman

3.6. Noise developments NF

Still in our objective to evaluate the optical amplifiers, we represent in Figure 6, the respective NF of these three amplifiers as a function of a wavelengths. It is also composed of three sub-figures respectively Figure 6(a), Figure 6(b), and Figure 6(c). this evaluation is made for a distance between 0 and 90 Km. In Figure 6(a), the noise figure decreases as a function of the wavelength for SOA. The higher the wavelength, the more the noise decreases until it reaches 27 around 1558 nm. Noise is therefore one of the disadvantages of this amplifier in the third transmission window, which justifies the fact that it is only reserved for transmissions of wavelength 980 nm. In Figure 6(b), like the SOA, the noise of the EDFA decreases as the wavelength is increased with the only difference that it tends towards stabilization for $1566 < \lambda < 1558$ with a value relatively lower than that of the SOA, *i.e.* 5 dB against 27 dB. For the Raman amplifier in Figure 6(c), the same flatness is observed for the gain. However, some slight peaks occur around $1556 < \lambda < 1557$ nm especially for $40 < D < 80$ Km transmission. This flatness is considered to be one of the main advantages of Raman amplifiers.

3.7. Q-factors

The Figure 7 shows the quality factor Q of the optical amplifiers over a fiber length L. We present in Figure 7(a) the quality factor of SOA, in Figure 7(b) that of EDFA and finally, in Figure 7(c) the quality factor of Raman. In Figure 7(a), Q_{soa} corresponds to 5.8 for a length of 20 Km, this value will increase to 6 for a propagation of 40 Km. At this level, Q undergoes a sharp linear drop until 80 Km. The evolution of the quality factor Q_{soa} of the SOA amplifier can be summarized in two intervals, *i.e.* $5.8 < Q_{soa} < 6$ for $20 < L < 40$ Km and $6 > Q_{soa} > 4$ for $40 < L < 80$ Km. Finally, for Figure 7(c), the Q_{Raman} quality factor decreases from 18 to 9 up to 40 km, at which point it stabilizes at a distance L of 20 km before falling back to a Q_{Raman} value of 3.3 between a distance L of 60 km and 80 km. Its evolution can be summarized in three intervals.

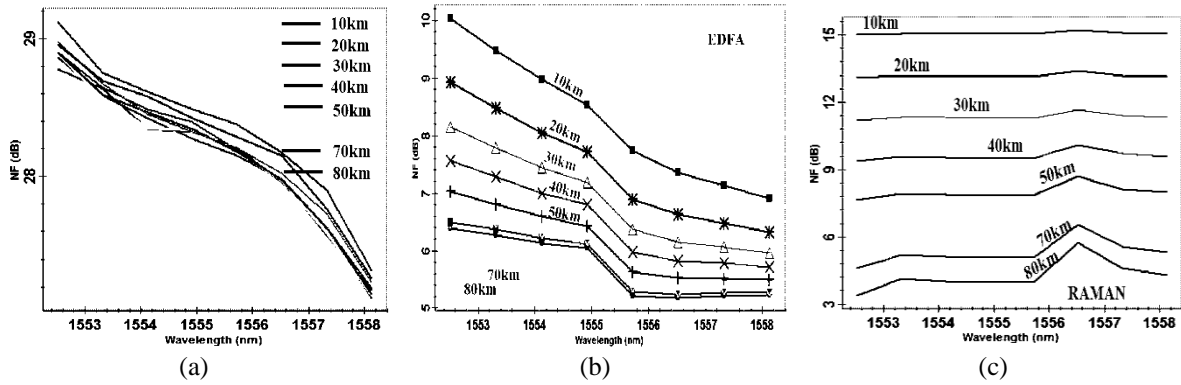

Figure 6. Evolution of the respective noise as a function of wavelength, (a) NF SOA, (b) NF EDFA, and (c) NF Raman

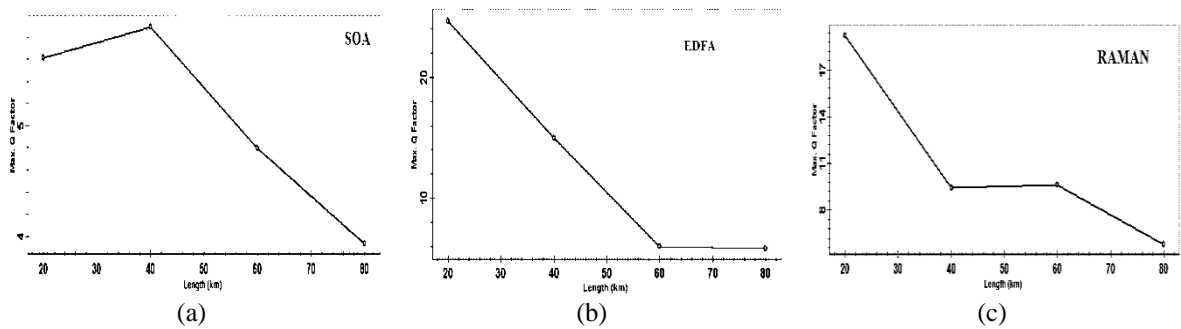

Figure 7. Quality factor Q of the amplifiers over a length L of 80 Km, (a) Q_{SOA} , (b) Q_{EDFA} , and (c) Q_{Raman}

3.8. Eye diagram

The eye diagram represented in Figure 8 allows to evaluate the quality of transmission after having introduced the various amplifiers. For this propose, this figure is composed of three others sub-figures, respectively for the SOA, the EDFA and Raman. The SOA eye diagram in Figure 8(a), shows time jitter with a strong tendency to close the eye; this aspect reflects a strong presence of noise in the signal, indicating poor reception. This result justifies one of the main reasons why the use of SOA enhancers is limited in optical transmissions. Then the eye diagram in Figure 8(b), shows a more open eye with less overlap between the temporal jitter, which explains why with this amplifier we can obtain a better quality signal. Similarly to Figure 8(b), the eye diagram in Figure 8(c) also forms a more open eye with more ordered jitter, so there is a possibility to get a good quality signal with Raman.

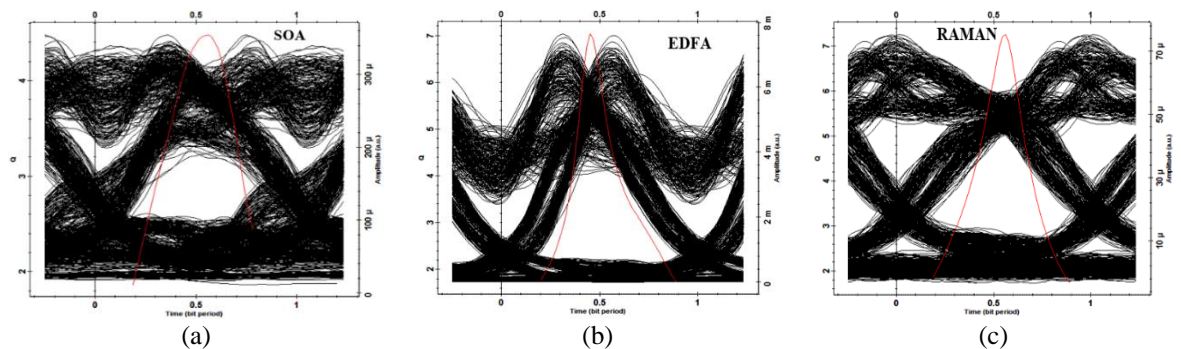

Figure 8. Eye diagram of the optical amplifiers in (a) SOA, (b) EDFA, and (c) Raman

4. CONCLUSION

In this paper, the operating parameters of optical amplifiers were evaluated in order to identify their preferred field of application in optical telecommunications and to improve the architecture of access networks through the integration of optical amplifiers. It was found that the optical semiconductor amplifier has several limitations mainly on the noise aspect where an almost firm eye and also an uncontrolled noise evolution could be observed. We note, however, that it has a better gain stability than the Erbium doped fiber amplifier, just like the Raman amplifier. This advantage seems to us to be insufficient for current optical transmissions in telecommunications networks. As for the EDFA amplifier, very interesting results were obtained, notably on the QEDFA quality factor between $3.3 < \text{QEDFA} < 25$, a good transmission quality, with less noise confirmed by the eye diagram and also an evolution of the gain G that could go beyond 10 dBm even if the latter was not very stable. The Raman amplifier was distinguished by a high stability in most of the evaluated parameters, i.e. the gain and the noise signal. Also, its eye diagram showed us that a better signal quality could be achieved in the transmission. In view of the above and the results obtained, we can conclude that it is important to integrate EDFA and Raman amplifiers into optical transmissions in order to meet the needs of new services. In the future, we will be able to carry out a study on the combination of these two amplifiers in the same traffic and evaluate their contribution.



REFERENCES

- [1] L. Krzczanowicz *et al.*, "Low transmission penalty dual-stage broadband discrete Raman amplifier," *Optics Express*, vol. 26, no. 6, pp. 7091-7097, 2018, doi: 10.1364/OE.26.007091.
- [2] M. K. Gupta, Ambrish, and G. Singh, *Next generation PON with enhanced spectral efficiency analysis and design*, Singapore: Springer, 2020.
- [3] D. Breuer *et al.*, "Opportunities for next-generation optical access," in *IEEE Communications Magazine*, vol. 49, no. 2, pp. s16-s24, February 2011, doi: 10.1109/MCOM.2011.5706309.
- [4] J. Capmany, B. Ortega and D. Pastor, "A tutorial on microwave photonic filters," in *Journal of Lightwave Technology*, vol. 24, no. 1, pp. 201-229, Jan. 2006, doi: 10.1109/JLT.2005.860478.
- [5] L. Li, X. Yi, T. X. H. Huang and R. Minasian, "High-resolution single bandpass microwave photonic filter with shape-invariant tunability," in *IEEE Photonics Technology Letters*, vol. 26, no. 1, pp. 82-85, Jan. 1, 2014, doi: 10.1109/LPT.2013.2288972.
- [6] S. Hanatani, "Overview of global FTTH market and state-of-the-art technologies," in *2013 18th OptoElectronics and Communications Conference held jointly with 2013 International Conference on Photonics in Switching*, 2013, p. WP4_1, doi: 10.1364/OECC_PS.2013.WP4_1.
- [7] U. Gustavsson *et al.*, "Implementation challenges and opportunities in beyond-5G and 6G communication," in *IEEE Journal of Microwaves*, vol. 1, no. 1, pp. 86-100, Jan. 2021, doi: 10.1109/JMW.2020.3034648.
- [8] S. Dang, O. Amin, B. Shihada, and M.-S. Alouini, "What should 6G be?," *Nature Electronics*, vol. 3, no. 1, pp. 20-29, Jan. 2020, doi: 10.1038/s41928-019-0355-6.
- [9] P. M. Jaff, "Characteristic of discrete raman amplifier at different pump configurations," *World Academy of Science, Engineering and Technology*, vol. 54, no. 2, pp. 737-739, 2009, doi: doi.org/10.5281/zenodo.1071053.
- [10] C. Vergien, I. Dajani, and C. Zeringue, "Theoretical analysis of single-frequency Raman fiber amplifier system operating at 1178nm," *Optics Express*, vol. 18, no. 25, p. 26214, Dec. 2010, doi: 10.1364/OE.18.026214.
- [11] K. A. Mohammed and B. M. K. Younis, "Comparative performance of optical amplifiers: Raman and EDFA," *TELKOMNIKA (Telecommunication Computing Electronics and Control)*, vol. 18, no. 4, pp. 1701-1707, Aug. 2020, doi: 10.12928/telkomnika.v18i4.15706.
- [12] P. Zhou *et al.*, "High-gain erbium silicate waveguide amplifier and a low-threshold, high-efficiency laser," *Optics Express*, vol. 26, no. 13, p. 16689, Jun. 2018, doi: 10.1364/OE.26.016689.
- [13] M. Tan, P. Rosa, S. T. Le, I. D. Phillips, and P. Harper, "Evaluation of 100G DP-QPSK long-haul transmission performance using second order co-pumped Raman laser based amplification," *Optics Express*, vol. 23, no. 17, p. 22181, Aug. 2015, doi: 10.1364/OE.23.022181.
- [14] P. Chanclou, A. Cui, F. Geilhardt, H. Nakamura and D. Nessel, "Network operator requirements for the next generation of optical access networks," in *IEEE Network*, vol. 26, no. 2, pp. 8-14, March-April 2012, doi: 10.1109/MNET.2012.6172269.
- [15] L. Zhang, Y. Luo, N. Anwari, B. Gao, X. Liu and F. Effenberger, "Enhancing next generation passive optical network stage 2 (NG-PON2) with channel bonding," *2017 International Conference on Networking, Architecture, and Storage (NAS)*, 2017, pp. 1-6, doi: 10.1109/NAS.2017.8026856.
- [16] G. Kaur, S. Sharma, and G. Kaur, "Novel Raman parametric hybrid l-band amplifier with four-wave mixing suppressed pump for terabits dense wavelength division multiplexed systems," *Advances in Optical Technologies*, vol. 2016, no. 17, pp. 1-8, Feb. 2016, doi: 10.1155/2016/6148974.
- [17] M. Chakkour, A. Hajaji, O. Aghzout, F. Chaoui, and M. El Yakhouloufi, "Design and study EDFA-WDM optical transmission system using FBG at 10Gbits/s chromatics dispersion compensation effects," *Mediterranean Conference on Information & Communication Technologies '2015*, 2015.
- [18] B.-N. Hu, W. Jing, W. Wei and R.-M. Zhao, "Analysis on dispersion compensation with DCF based on Optisystem," *2010 2nd International Conference on Industrial and Information Systems*, 2010, pp. 40-43, doi: 10.1109/INDUSIS.2010.5565685.
- [19] C. DeSanti, L. Du, J. Guarin, J. Bone and C. F. Lam, "Super-PON: an evolution for access networks [Invited]," in *Journal of Optical Communications and Networking*, vol. 12, no. 10, pp. D66-D77, October 2020, doi: 10.1364/JOCN.391846.
- [20] D. Nessel, "PON Roadmap [Invited]," *Journal of Optical Communications and Networking*, vol. 9, no. 1, p. A71, Jan. 2017, doi: 10.1364/JOCN.9.000A71.
- [21] P. Chanclou *et al.*, "Access network evolution: optical fibre to the subscribers and impact on the metropolitan and home networks," *Comptes Rendus Physique*, vol. 9, no. 9-10, pp. 935-946, Nov. 2008, doi: 10.1016/j.cry.2008.10.010.
- [22] D. Meena and M. L. Meena, "Design and analysis of novel dispersion compensating model with chirp fiber bragg grating for long-haul transmission system," in *Optical and Wireless Technologies*, Singapore: Springer, 2020, pp. 29-36.



- [23] B. H. Ali, "Performance comparison between direct and external modulation using RZ and NRZ coding," *ELEKTRIKA-Journal of Electrical Engineering*, vol. 19, no. 1, pp. 1–8, Apr. 2020, doi: 10.11113/elektrika.v19n1.144.
- [24] M. Gilmore, "An overview single mode optical fibre specification," *FIA*, 2017.
- [25] V. Sasikala and K. Chitra, "Effects of cross-phase modulation and four-wave mixing in DWDM optical systems using RZ and NRZ Signal," in *Optical and Microwave Technologies*, Singapore: Springer, 2018, pp. 53–63.
- [26] L. E. Nelson, X. Zhou, B. Zhu, M. F. Yan, P. W. Wisk and P. D. Magill, "All-raman-amplified, 73 nm seamless band transmission of 9 Tb/s over 6000 km of fiber," in *IEEE Photonics Technology Letters*, vol. 26, no. 3, pp. 242-245, Feb.1, 2014, doi: 10.1109/LPT.2013.2291399.
- [27] M. A. Iqbal *et al.*, "Noise and transmission performance improvement of broadband distributed Raman amplifier using bidirectional Raman pumping with dual order co-pumps," *Optics Express*, vol. 25, no. 22, p. 27533, Oct. 2017, doi: 10.1364/OE.25.027533.
- [28] T. Ivaniga and P. Ivaniga, "Comparison of the optical amplifiers EDFA and SOA based on the BER and Q-factor in C-band," *Advances in Optical Technologies*, vol. 2017, no. 22, pp. 1–9, Jan. 2017, doi: 10.1155/2017/9053582.

BIOGRAPHIES OF AUTHORS





Bimogo Joseph Armel    is assistant Professor at the University of Douala (Advanced Teachers' Training College for Technical Education). He Holds a Master Research in Technology and Applied Sciences. He is preparing a Ph.D. thesis in Telecommunications Optics in the Laboratory of Technology and Applied Sciences in university of Technology, Cameroon (Douala). His research areas are telecommunication optics. To his credit, he as 2 papers. He can be contacted at email: barelbimogo@yahoo.com.



Essiben Dikoundou Jean-Francois    is associate Professor at advanced teacher's training college for technical education, University of Cameroon (Douala). He Holds a M.S. degree in radiocommunication, radiobroadcasting and television from Tashkent Institute of Electro-technical and communications, Tashkent, Uzbekistan (former USSR), in 1993 and his Ph.D. degree from the Taganrog State University of Radio Engineering (Russia), in 2004. His research areas are geolocalisation, radiolocalisation and optical telecommunications. To his credit, he as 41 papers. He can be contacted at email: jessibenm@yahoo.fr.



Ihonock Eyembe Luc    is assistant Professor at the University of Douala (Advanced Teachers' Training College for Technical Education). He Holds a Master Research in Technology and Applied Sciences. He is preparing a Ph.D. thesis in telecommunications optics in the laboratory of technology and applied sciences in University of Technology, Cameroon (Douala). His research areas are Antennas. He can be contacted at email: eyembeluc@yahoo.fr.