

An Agent-based Improved Task Decomposition Model for Multiple Expert Systems

Li Yang^{*1, 2}, Xiedong Cao¹, Jie Li¹

¹College of Computer, Southwest Petroleum University, Chengdu, 610500, China, +86- 817-2642308

²College of Computer, Sichuan University, Chengdu, 610065, China, +86-028-85990972

*Corresponding author, e-mail: yanglispu@163.com

Abstract

To solve task decomposition of multi-expert system, agent-based task decomposition model and algorithm based on dependency is introduced. Firstly, AND/OR dependency graph for operation set is presented. Formal description of task decomposition based on With AND/OR dependency graph, is proposed. Secondly, task decomposition algorithm based on operation dependency is analyzed to solve communication among agents. Analysis of algorithm performance and instance are discussed, collaboration work flow between expert agents are analyzed and can solve the collaboration problem among expert-agents very well. For illustration, expert system for oil-gas reservoir protection is utilized to verify the effectiveness of the method. Finally, multi-expert system based on our proposed algorithm shows that our proposed model has good time and space efficiency, and support task dynamic decomposition and can effectively solve the collaboration of experts in the multiple-expert system and improve the accuracy of inference.

Keywords: Intelligent agent, Dependency relationship, Multi-expert, Task decomposition

Copyright © 2013 Universitas Ahmad Dahlan. All rights reserved.

1. Introduction

Reservoir protection expert system mainly consists of five subsystems, such as reservoir sensitivity evaluation, potential damage, reservoir damage diagnosis, reservoir damage prediction and reservoir damage processing. Each subsystem is a expert system and they need to share knowledge and collaborative work among each subsystems [1-2]. Thus, single expert subsystem has not met the requirements of large-scale knowledge processing in oilfield reservoir protection. Therefore, many expert subsystems are needed to together build an intelligent comprehensive multiple-expert system to solve practical problems [3-5].

Multi-agent system (MAS) is composed of various agents which have simply structure and independent functions, which can organize and coordinate many intelligent agents to complete a common task. More and more computer systems can be taken as various, autonomous agents. With the coordination and collaboration of agents, the whole computer system can work better and better. In distributed and open multi-agent system, firstly, tasks are decomposed into multi-subtasks, then the subtasks are allocated to agents to be executed.

Task composition, allocation and task scheduling are important research issues in MAS. Conceptual model based on role is presented in [6]. Heuristics algorithm [7] converts task decomposition problem into two simple problems: (1) Heuristics algorithm is used to generate operation set which satisfied task constraint condition; (2) The operations generated by the prior step are allocated to execution units. In this paper, in order to formalize the dependence relations of operations, the concept of and-or dependency graph is introduced, then a construction algorithm of and-or dependency graph is put forward. An applied instance of the algorithm shows that the algorithm has good time and space efficiency, and support task dynamic decomposition.

2. AND/OR Dependency Graph for Operation Set

Definition 1: Task is represented as $T = \langle K, A, P, I, G \rangle$.

Where

K is a knowledge set in a problem which includes initial condition, global data, local data, all objects and intermediate results;

A is an operation set, which can get corresponding output result and by which the given tasks can be finished.

P is a set of task-executive agents;

I is an initial condition of the task which is ready for execution and is the subset of K.

G is an object set, which includes the results from the completed task, and is the subset of K.

C and G have defined the tasks. K, O, P have defined the environment in which tasks can be executed.

Definition 2: AND/OR graph for operation set is a digraph, which can be rewritten as a triple (N, Eor, Eand).

Where N is a node set which represents operation set of task.

$Eor \subseteq N \times N, Eand \subseteq N \times N$ is an edge set which is used to represent dependency relationship among operations.

$\langle a_1, a_2 \rangle \in Eor$ describes that node a_1 depends on a_2 in OR way, $\langle a_1, a_2 \rangle \in Eand$ describes that node a_1 depends on a_2 in AND manner.

Definition 3: $\{a_i | \langle a, a_i \rangle \in Eor\}$ is called as OR dependency set of operation, a, where Eor is Or connection edge set in AND/OR dependency graph (A, Eor, Eand). Node, a, a_i is respectively an element of node set, A.

Definition 4: $\{a_i | \langle a, a_i \rangle \in Eand\}$ is called as AND dependency set of operation, a, where Eand is And connection edge set in AND/OR dependency graph(A, Eor, Eand). Node, a, a_i is respectively an element of node set, A.

Consider task, $T_1 = \langle K, A, P, I, G \rangle$, where:

$K = \{k_0, k_1, k_2, \dots, k_{11}\}, I = \{k_0, k_1, k_2, k_3, k_4\}, G = \{k_6, k_7\}, A = \{a_1, a_2, a_3, a_4, a_5\}$.

Input information and output information for each operation is shown in Table 1.

Table 1. Input information and output information for each operation

Operation	Input information	Output information
a_1	$\{k_0, k_1, k_2, k_3, k_4\}$	$\{k_{11}\}$
a_2	$\{k_0, k_1, k_2, k_3, k_8, k_{11}\}$	$\{k_6\}$
a_3	$\{k_0, k_1, k_3, k_8\}$	$\{k_7\}$
a_4	$\{k_1, k_{11}\}$	$\{k_8\}$
a_5	$\{k_0, k_{11}\}$	$\{k_8\}$

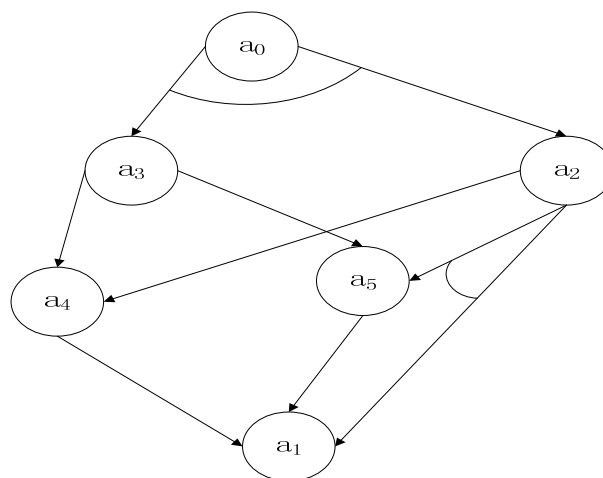

Figure 1. AND/OR dependency graph for operation

AND/OR dependency graph for each operation of T1 is illustrated in Figure 1. The sign, a0 represents the whole task, AND dependency relationship is depicted by a short segment of arc.

3. Task Decomposition Model Based on AND/OR Dependency Graph

3.1. Task Decomposition Model

In MAS, the main aim of task decomposition is that the task to be processed, T, are decomposed into multiple high parallelism subtasks $\{t_1, t_2, \dots, t_i, \dots, t_n\}$. The decomposed subtasks together complete the general task in the shortest time with the following conditions: (1) Only if all operations get necessary input information, they begin to perform. (2) All knowledge will be obtained in the target.

To discuss conveniently, firstly, Let set $T = \{t_1, t_2, \dots, t_i, \dots, t_m\}$ be a decomposition of task T, where $t_i = \langle K_i, A_i, P_i, I_i, G_i \rangle$ is decomposed subtask. K_i is subset of knowledge set, A_i is subset of operation set, P_i is subset of task-executive agents set, I_i is input knowledge set of A_i , G_i is output knowledge set of A_i , the time to complete the task is represented by $C(T)$.

Obviously, task decomposition problem for MAS has the following constraints:

Constraint 1: each subtask has one operation at least, that is to say, $|A_i| \geq 1$. The constraint ensures the subtasks are not idle.

Constraint 2: define subtask scale factor as $k = \text{maximum subtask scale} / \text{minimum subtask scale}$, k is determined according to the time spent by operation set of subtasks to ensure the load balance of each agent.

Constraint 3: the number of subtasks, s , should be in value interval $[s_1, s_2]$, that is to say, $s_1 \leq |T| \leq s_2$.

Constraint 4: If k_i is not shared knowledge, operation a_j containing k_i belongs to t_k , then K_i belongs to subtask t_k .

Constraint 5: If operation a_j containing non-shared knowledge k_i , and a_j does not belong to subtask t_k , then k_i does not belong to subtask t_k .

Constraint 6: Each operation a_j can be performed once at most.

Constraint 7: Output union of all subtasks operation sets must cover target set.

Constraint 8: Each operation a_j can only be performed when its input knowledge is satisfied.

As a result, task decomposition problem changes into the problem of finding the minimum of $C(T)$ with satisfying all constraints from 1 to 8.

3.2. Task Decomposition Algorithm Based on Operation Dependency

From the preceding analysis, we can draw a conclusion that if operation set of the task can be constructed to a AND/OR dependency graph according to dependence relationship, then task decomposition problem can be changed to the problem of finding the optimal solution by searching AND/OR graph. Based on the above-mentioned conclusion, three algorithms of problem solving are proposed, such as the algorithm for constructing AND/OR dependency graph, dependency algorithm, subtask generating algorithm. The three algorithms are depicted in detail as follows:

Algorithm 1: the algorithm for constructing AND/OR dependency graph

- (1) Take original task as initial node a_0 and choose node a_0 as current node;
- (2) Extend the current node according to input knowledge and output knowledge of each operation in operation set A;
- (3) Set the pointer of child node to its parent node;
- (4) Choose appropriate child node as current node, repeat step (2) and (3) until all operation nodes are created.

Algorithm 2: Dependency set generating algorithm according to AND/OR dependency graph

```

For each node, a, in AND/OR dependency graph do
  IF out-degree of a =0 Then
    Begin
      AND dependency set and OR dependency set is made empty;
    End
  Else
    Begin
      AND dependency set of a can be represented as  $\{a_i | <a, a_i > \in E_{and}\}$ ;
      OR dependency set of a can be represented as  $\{a_i | <a, a_i > \in E_{or}\}$ ;
    End
  
```

Algorithm 3: Breadth-first task decomposition algorithm based on AND/OR dependency graph

Let, Graph, be AND/OR dependency graph of the task, let ,G, be target knowledge set of the task.

A^* represents feasible operation set for decomposition, S is used to store node set.

Repeat

(1) Find all nodes that their out-degree is equal to zero in Graph;
 (2) Sort all nodes that their out-degree is equal to zero by output knowledge and obtain sequence S ;

(3) Output operations which have the same knowledge of S and reserve minimum height operations;

(4) For each operation in S , if its output knowledge is in other operations of S , then delete the operation.

(5) For $i=1$ to $|S|$ do

Begin

If output knowledge set in $S_i \subseteq G$ then

Begin

Add s_i to A^* , and delete all knowledge obtained by s_i in G ;

End

If s_i and its dependency operations are not in A^* , then add the operations to A^* ;

End

(6)Delete each node that its out-degree is equal to zero and its edge relationship.

Until ($|Graph|=0$ or $|G|=0$)

4. Analysis of Algorithm Performance and Instance

The task decomposition process is shown in Table 2. AND/OR dependency graph of Operation set constructed by algorithm 1 is illustrated in Figure 2.

Table 2. Task decomposition process based on AND/OR dependency graph

Step	Output operation subset	Current target	Current parallel operation
1	{a1}	{k6, k7, k8, k10}	{a1}
2	{a2, a4, a8, a11, a12}	{k7, k10}	{a8, a11} or {a8, a12}
3	{a3, a7, a9}	{k7, k10}	{}
4	{a5, a6}	{k10}	{a5} or {a6}
5	{a10}	{}	{a10}

As shown in Table 3, Our proposed method has the following advantages compared with tradition method: (1) In our proposed method, all parallel-execution operation set can be obtained by decomposition each time;(2) Our proposed method supports dynamic task decomposition; (3) Iterations in our proposed method are performed according to hierarchy, many operations are in a hierarchy, so the algorithm has good time efficiency [8].

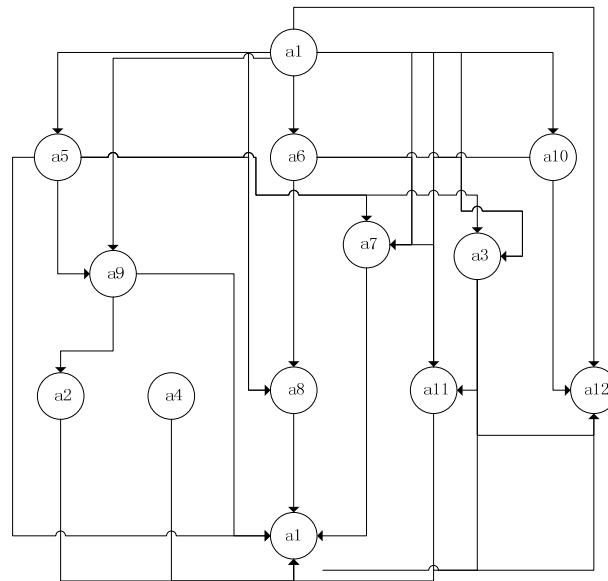

Figure 2. AND/OR dependency graph

Table 3. Comparison between our proposed algorithm and tradition algorithm

Comparison result	Our proposed algorithm	Tradition algorithm
Time-complexity	The number of the loop are linear with levels of the graph	The number of the loop are linear with operations
Result of algorithm	All parallel operation sets	A parallel operation set
Operation parallel	Yes	No

5. Implementation of Multiple Expert Systems for Oil-Gas Reservoir Protection

5.1. Sub-System Function of Multiple Expert Systems for Oil-Gas Reservoir Protection

Multi-agent technology is introduced into expert system to make expert system have better capability of interaction and autonomy. Each expert system has own knowledge about some field, own special knowledge representation and all kinds of reason methods [9]. This makes single expert system not only independently solve some problems, but also solve cross-field problems with other expert system. This expert system has the character of autonomy and sociality of agent technology, so the expert system can be taken as a expert agent [10-14]. There are many expert agents in the system, Therefore, multiple expert systems for oil-gas reservoir protection can be looked as a multi-agent system.

Expert systems for oil-gas reservoir protection mainly consist of the following five subsystems: reservoir sensitivity prediction sub-system, reservoir potential damage sub-system, reservoir damage diagnosis sub-system, reservoir damage prediction sub-system and reservoir damage processing sub-system.

5.2. Collaboration Work Flow between Expert Agents

According to different feature of field knowledge and basic idea of task assignment, expert Systems for oil-gas reservoir protection reasonably decompose general task into many sub-tasks such as reservoir sensitivity prediction sub-system, reservoir potential damage sub-system, reservoir damage diagnosis sub-system, reservoir damage prediction sub-system and reservoir damage processing sub-system, which are overlapping and can be completed by different sub-expert system. Each sub-system can be decomposed to form a tree structure. Each branch may have multiple solutions, therefore, there exists a set which includes many solutions. Invalid solutions need to be deleted in order to get feasible solutions.

In this expert system, each expert agent can independently complete solving a particular problem. If expert agent is able to complete the task proposed by users, then it puts

the task into its own task queue and start its own expert system to reason and solve the task, otherwise it puts the task into the delegation task queue, distributes the task to the experts in friend database and begins to negotiate. The collaboration process based on contract net is shown in Figure 3.

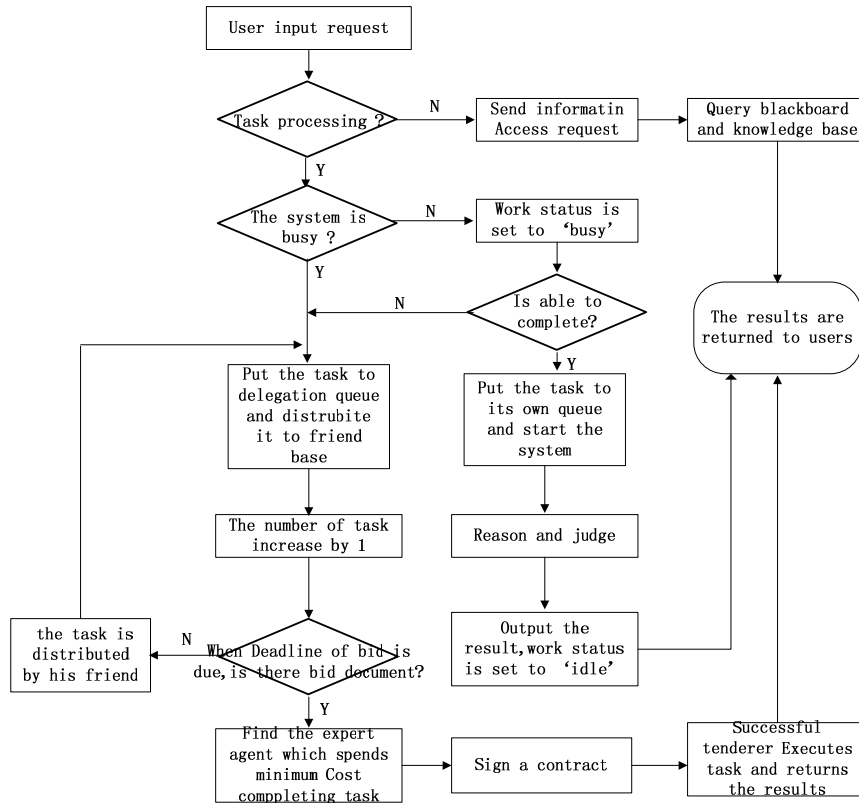

Figure 3. The collaboration process based on contract net

5.3. Sub-Expert Agent Structure Based on Blackboard Model

Each sub-agent includes its own independent knowledge base, reasoning machine, local blackboard, knowledge acquisition component, and etc [15-17]. Their main task is to maintain its own knowledge base, then, reason and design in terms of design task document and its own knowledge on the global blackboard, finally, return the final result to users after completing task. Sub-agent structure is illustrated in Figure 4.

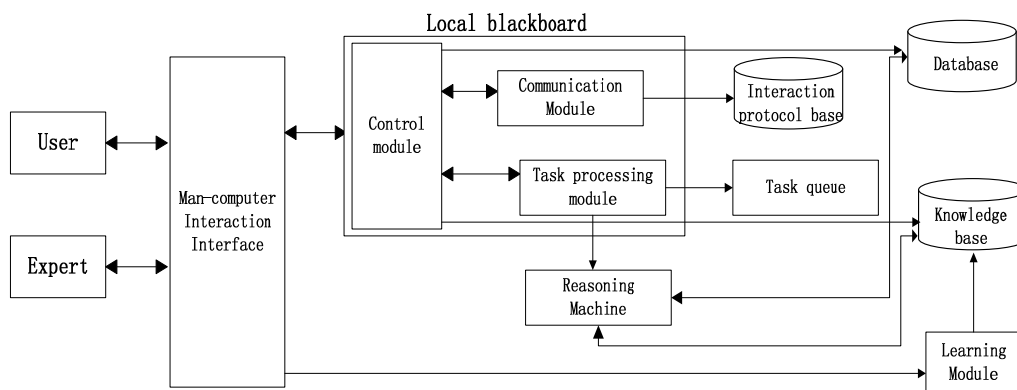

Figure 4. Task sub-agent Structure

Expert agent not only has the main functions of expert system, but also has relevant features of agent. The new functions in expert agents make the collaboration among multi-expert agents more convenient.

Learning module makes expert agent have intelligence, it can acquire new knowledge through user interface and update knowledge base in time with combining intermediate collaboration result in database. Local blackboard includes communication module and task processing module [18], which are controlled by a master module. Task queue includes local task queue, collaboration task queue and delegation task queue. Local task queue stores the tasks which can be solved by local agent, collaboration task queue stores the tasks which are asked for by other expert agents, and delegation task queue stores the tasks which local agents need other agents to cooperatively solve.

5.4. Implementation of Embedding XML in KQML

In KQML content layer, KQML format is not fixed which can be written in different language. In general, program language in the content is determined in language domain. The program language representing knowledge sharing must be able to express a behavior, an element and object. XML embedded in KQML makes the content written by XML easier to analyze semantics. XML document type is tree structure, a node has many childnodes. In the system, when agent 1 needs to send a message to agent 2, the message written by XML is embedded in KQML content layer, then is packed into XML document. Agent 2 parses the received message. If agent 2 needs to response, it packs the answer into a XML document which will be sent to agent 1. The message format of embedding XML in KQML is as follows:

KQML message format:

```
( ask-one
  :sender Agent1
  :receiver Agent2
  :reply-with id0
  :in-reply-with id1
  :language Prolog
  :ontology expert
  :content )
```

XML format:

```
<?xml version="1.0"encoding="utf-8"?>
<Message xmlns:xsd="http://www.w3.org/2001/XMLSchema"
xmlns:xsi="http://www.w3.org/2001/XMLSchema-instance">
<Performative>ask-one</Performative> //KQML operation
<Sender>Agent1</Sender> //KQML sender
<Receiver>Agent2</Receiver>//KQML receiver
<in-reply-to> id0</in-reply-to>
<reply-with>id1</reply-with >
```

5.5. Results and Discussions

Multiple expert system can improve the ability and affectivity of solving problems [5]. Incomplete knowledge and correlation knowledge between each expert subsystem make cooperative task problems become an important issue in the research of multiple expert system [6]. Multiple-expert system needs to solve some specific problems as follows: task decomposition and assignment, knowledge transfer, conflict processing and work status change of each expert subsystem.

The maturity of the agent theory and the advent of intelligent agent and multi-agent system have provided a new method for cooperative work of expert system of oilfield reservoir protection. The expert system of oilfield reservoir protection can be taken as a complicated problem which can be decomposed into many simple subproblems, (or subsystem). The subproblems (subsystems) can be cooperatively worked by multi-agent system to attain the solution of the complicated problem. Cooperative work of expert system is the key of expert systems, but task decomposition is the basis of Cooperative work, therefore, it is highly significant to make a research on based-agent task decomposition model of multiple expert systems for oil-gas reservoir protection.

6. Conclusion

Task decomposition has become one of important issue in multi-agent system. Multi-agent technology is introduced to expert systems for oil-gas reservoir protection to provide a new method to achieve task decomposition, to implement the collaboration among multi-experts by point-to point blackboard mechanism. In this paper, task decomposition algorithm based on AND/OR dependency graph is proposed. The proposed method is applied to expert systems for oil-gas reservoir protection to verify that our proposed model has good time and space efficiency, and support task dynamic decomposition and can effectively solve the collaboration of experts in the multiple-expert system and improve the accuracy of inference. The next work is to research on learning mechanism of agent to improve learning ability of agent.

Acknowledgements

This work was supported National Natural Science Foundation Project under grants 61175122, 61173182 and 61179071, as well as by Applied Basic Research Project (2011JY0124) and International Cooperation and Exchange Project (2012HH0004) of Sichuan Province.

References

- [1] M Reina. Applying Expert Systems in Heavy/Extra Heavy Oil Production Operation. *SPE 27057*. 1994.
- [2] Chunwei Chen. A Usability Inspection Expert System based on HE, GRY and GST. *International Journal of Intelligent Information Processing*. 2012; 3(1): 1-15.
- [3] Jian-hua Luo, Qing-hua Cao, Yong-Ming Chen. An Expert Teaching System Based on the Production Rules. *International Journal of Digital Content Technology and its Applications*. 2011; 5(9): 264-271.
- [4] FH Wu. Development of an Expert System for Water Control Application. *SPE27552*. 1994.
- [5] Liao SH. Expert system methodologies and applications - A decade review from 1995 to 2004. *Expert Systems with Applications*. 2005; 28(1): 93-103.
- [6] Cabri G, Ferrari L, Leonardi L. *BRAIN: A frame work for flexible role-based interactions in multi-Agent systems*. Oxford, UK: 1st European Workshop on Multi-Agent System EUMAS. 2003.
- [7] Zhu H. A role agent model for collaborative systems. Las Vegas, Nevada, USA: 2003 Int'l Conf on Information and Knowledge. *Engineering IKE'03*. 2003.
- [8] Shiue W, Li ST, Chen KJ. A frame knowledge system for managing financial decision knowledge. *Expert Systems with Applications*. 2008; 35(3): 1068-1079.
- [9] Yang WB, Zhang WY, Wang Y, Yao JR. Ontology-based Multi-perspective Task Decomposition to Support Composite Manufacturing Service Discovery. *International Journal of Digital Content Technology and its Applications*. 2011; 5(7): 290-296.
- [10] He Yuan, Yu Tao, Zhang Qiling. Granularity Control and Cohesion Measurement in Manufacturing Grid Task Decomposition. *Journal of Convergence Information Technology*. 2011; 6(7): 375-381.
- [11] Feng Liang, Haoming Guo, Shengwei Yi, Shilong Ma. A Multiple-Policy supported Attribute-Based Access Control Architecture within Large-scale Device Collaboration Systems. *Journal of Networks*. 2012; 7(3): 524-531.
- [12] Poondi Srinivasan Pandian, Kadavath Peedikayil Safeer, Doddamallur Thirumala Iyengar Shakunthala, Parvati Gopal, Vinod Chidambar Padaki. Store and Forward Applications in Telemedicine for Wireless IP Based Networks. *Journal of Networks*. 2007; 2(6): 58-65.
- [13] Xiaoyuan Bao, Yanzhong Jin. XPath Query Completeness Verification Algorithms in DAS. *Journal of Networks*. 2010; 5(10): 1143-1150.
- [14] Jahromi MZ, Parvinnia E, John R. A method of learning weighted similarity function to improve the performance of nearest neighbor. *Information Sciences*. 2009; 179(17): 2964-2973.
- [15] COLOMBO AW, SCHOOP R, NEUBERT R. An agent-based intelligent control platform for industrial holonic manufacturing systems. *IEEE Trans on Industrial Electronics*. 2005; 53(7): 322-337.
- [16] Xia Li, Juan Chen. Research on Knowledge Acquisition and Reasoning Mechanism of Pathologic Diagnosis Expert System. *Journal of Convergence Information Technology*. 2012; 7(20): 550-556.
- [17] LI Ai-Ping, Jia Yan, WU Quan-Yuan. A Study on Organizational Knowledge in Multi-Agent System. *Journal of Convergence Information Technology*. 2007; 2(1): 61-65.
- [18] Feng Liang, Haoming Guo, Shengwei Yi, Shilong Ma. A Multiple-Policy supported Attribute-Based Access Control Architecture within Large-scale Device Collaboration Systems. *Journal of Networks*. 2012; 7(3): 524-531.