

Instrumentation system for data acquisition and monitoring of hydroponic farming using ESP32 via Google Firebase

Prisma Megantoro¹, Rizki Putra Prastio¹, Hafidz Faqih Aldi Kusuma¹, Abdul Abror¹,
Pandi Vigneshwaran², Dimas Febriyan Priambodo³, Diaz Samsun Alif¹

¹Department of Engineering, Faculty of Advanced Technology and Multidiscipline, Universitas Airlangga, Surabaya, Indonesia

²Department of Computer Science, Faculty of Science and Humanities, SRM Institute of Science and Technology, Chennai, India

³Polytechnic of National Cyber and Password (Poltek SSN), Bogor, Indonesia

Article Info

Article history:

Received Feb 10, 2022

Revised Apr 22, 2022

Accepted May 19, 2022

Keywords:

Agricultural innovation

Hydroponic farming

Internet of things

Product innovation

Smart meter

ABSTRACT

This article discusses the design of a hydroponic planting process monitoring system based on the internet of things. This device uses an ESP32 microcontroller board as the main controller. The parameters that were monitored and acquired were the conditions of the hydroponic growing media. Those parameters are; water pH, water temperature, water turbidity level, and ambient air temperature and humidity. The five parameters are measured by analog sensors integrated with the ESP32. These parameters affect the growth process and the quality of crop yields. This article also describes the calibration method for each sensor used for parameter measurement. Then the monitoring of these parameters is carried out by utilizing a real-time database, namely Google Firebase. This platform is very suitable for all IoT-based monitoring and control applications. Measurement result data is uploaded and saved to the real-time database. Then paired by Android-based applications. This application was created to be used by hydroponic farmers who use this device. Thus the results of monitoring can be used to optimize the process of growing hydroponic plants.

This is an open access article under the [CC BY-SA](https://creativecommons.org/licenses/by-sa/4.0/) license.



Corresponding Author:

Prisma Megantoro

Department of Engineering, Faculty of Advanced Technology and Multidiscipline

Universitas Airlangga, Surabaya, Indonesia

Email: prisma.megantoro@ftmm.unair.ac.id

1. INTRODUCTION

Hydroponic cultivation is one of the agricultural techniques without using soil so that it increases land efficiency and is quite easy to implement. This farming method offers good quality and quantity of production. Hydroponics can be done by anyone without having to undergo special education in agriculture [1]–[3]. In practice, hydroponic farmers carry out their activities using very simple and manual technology. Many farmers also often lack the facilities to support the production process [4]–[7]. Considering the quality and quantity of crop yields are influenced by several external factors such as weather, pest attack, and the number of nutrients provided, farmers must reduce or the effects mentioned above in order to obtain optimal yields. The lack of technology utilization makes it difficult to monitor nutrient water conditions. The proposed community service program aims to provide solutions to the problems above.

Nowadays, farmers have to measure with an instrument inserted into the nutrient water to determine its concentration and acidity (pH). Installations located in open spaces are also very susceptible to weather. If it rains, nutrient water will be mixed with rainwater. When the weather is hot enough, massive evaporation of water will occur. Of course, this will make the concentration of nutrients and the pH of the water very volatile which in turn will affect the quality and quantity of plants [8]–[11]. Several kinds of research have

been conducted on the topic of automation systems for hydroponics, one of which is the development of smart greenhouses for hydroponic farming by Andrianto *et al.* [12]. Monitoring and control of pH levels are automatically carried out by Saaid *et al.* [13]. Then Jirabhorn also created a management and control system for hydroponic farming in tropical climates [14]. In addition, similar research on the internet of things (IoT)-based hydroponic systems implemented for indoor spaces has also been carried out by Palande *et al.* [15]. Generally, the authors conducted a survey about implementation challenge of IoT technology to smart farming system [16]

The research in this article aims to build a monitoring system with integrated sensors, real-time measurements, able to provide information on water conditions, nutrients, and also provide warnings to farmers if conditions are not suitable. Different from the previous research, the device proposed in this article measures the 5 parameters of hydroponic farming media, such as; pH, TDS, water temperature, also air humidity and temperature. This reasearch also uses Firebase to give online access among user and devices on the field. The proposed method aims to apply automation technology that utilizes microcontrollers and the IoT in an effort to improve the quality and quantity of hydroponic agricultural products. With this method, hydroponic farming that are still heading towards productivity are expected to quickly move up to the productive step.

2. RESEARCH METHOD

This research is composed by four parts; namely hardware design, microcontroller firmware, real-time database, and Android application. Hardware design of the system consists of a PCB as interface circuitry for DC/DC converter, an ESP32 board, and the sensors used. The microcontroller firmware performs tasks in capturing and processing sensor data, displaying it on the LCD screen, and updating data to Firebase. Data uploaded to Firebase is stored and can be accessed by development tools using Android Studio. Android application design using Android studio version 4.3.

2.1. System design

Measurements are done to determine several parameters of plant conditions and planting media using analog sensors. For the water pH sensor, this work uses the analog V2 type product from DFRobot. This sensor is commonly implemented in such as hydroponics, aquascape, and environmental water testing [17]. This pH sensor greatly improved with more precision and more user experience [18]. The onboard voltage regulator IC supply voltage from 3.3 V to 5.5 V, which is compatible input voltage pin of ESP32. The output signal is filtered by the interface circuit and has low overall jitter. To measure the water temperature, a waterproof temperature sensor type DS18B20 is used and immersed in the planting medium. The TDS sensor uses the SKU type SEN0244 product from DFRobot. TDS obtains how many milligrams of solution solids are dissolved in one liter of fluid. Higher the TDS value, more solution solids are dissolved in water, and less the water is cleaner [19]. The TDS value can be used as a reference point for measure the cleanliness of water [20]. A TDS probe is used in this sensor set to measure TDS value. Finally, the DHT11 sensor is used to measure the temperature and humidity of the air [21]–[23]. The diagram of the whole system is depicted in Figure 1.

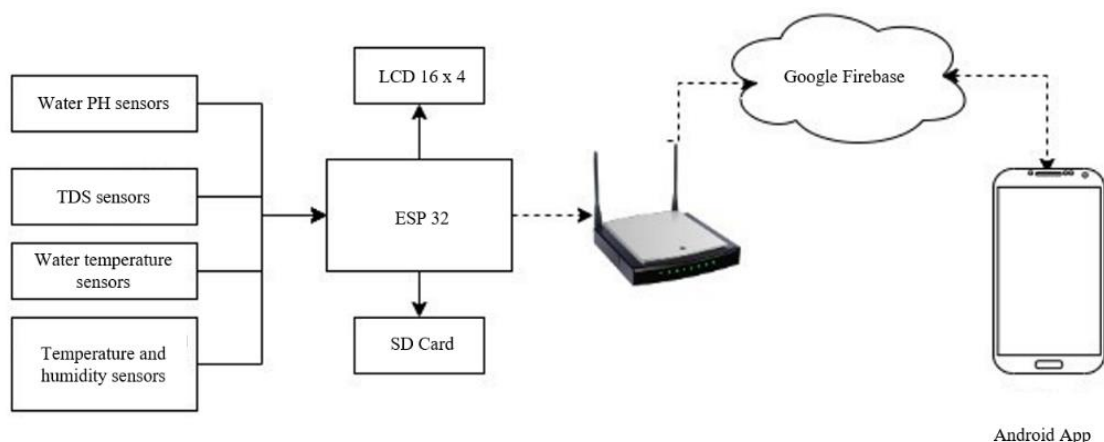

Figure 1. System block diagram

All sensors are integrated with the ESP32 microcontroller board. This microcontroller board takes data from each sensor, processes it into measurement data, displays the data on the LCD, saves the data to the SD card, then combines the data into one dataset and sends it to the real-time database on Google Firebase. The Android application installed on the smartphone device is used to display all measurement parameters and provide hydroponic system alert.

2.2. Hardware design

Figure 2 shows a schematic hardware diagram of the device in this research. This schematic is a set of interfaces designed to integrate the DC/DC step-down converter, ESP32 board, 16x2 LCD, sensors module, and pin connectors of the sensors. The ESP32 board used is the WROOM 32D development kit-C model. The ESP32 uses the Tensilica Xtensa LX6 microprocessor as the core. The ESP32 can be used as a complete stand-alone system or as a slave system to a host controller unit [24]–[28]. ESP32 can be paired with other systems to provide Wi-Fi functionality via its SPI or i2c interface. The DC/DC converter is used to lower the supply voltage to 5 V so that it can be used by the ESP32, LCD, and sensors. The LCD connected to the ESP32 i2c pin is used to display the system status and read data from the sensor.

This device uses three analog sensors to measure water pH, water temperature, and water turbidity or total concentration of dissolved substances (TDS). In addition to measuring water parameters, this device also uses digital sensors to measure air temperature and humidity.

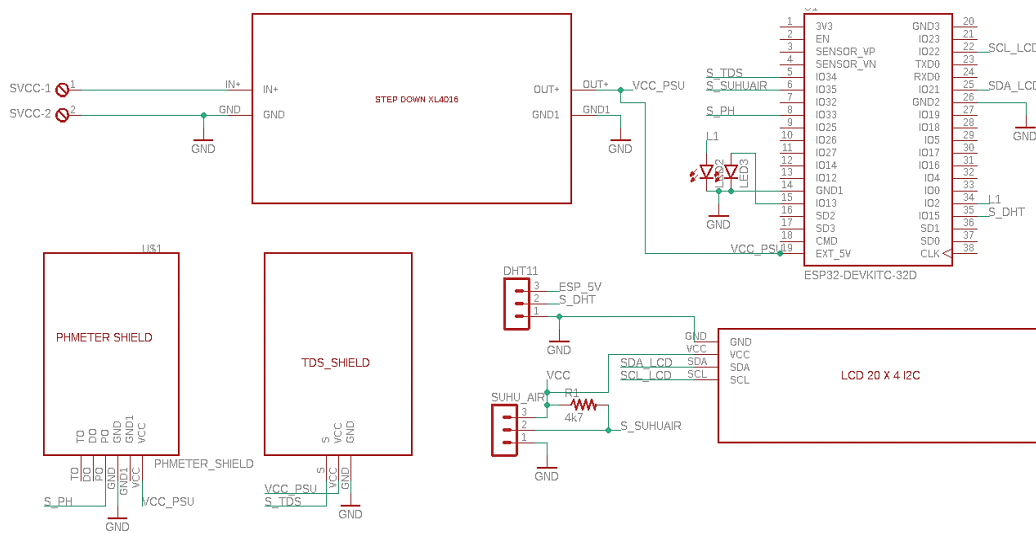

Figure 2. Schematic diagram of monitoring system

2.3. Firmware design

The firmware program for this monitoring device is designed using Arduino IDE. Arduino IDE is a cross-platform software for Windows, macOS, and Linux that is written and compiled in functions from C and C++ language. The IDE is used to write, compile, and upload programs to Arduino boards. It is also compatible with other development boards with the use of third party.

Figure 3 shows the two main component of the system, such as the program and the hardware. The program embedded into the main controller ESP32. The program workflow of the firmware implemented in the main processor ESP32 is shown in Figure 3(a). The main program entered as an infinite loop. The process starts to read data from all the sensors. Then check the network connection again to make sure that the ESP32 board is connected to the Wi-Fi network. The connection is continued to be parsed. The process used to simplify the data processing in the mobile Android application. The sensor's datas are then formulated into a regression equation to convert to real unit. The process continued to update the dataset to real-time database. If the connection is lost or the server database sent a failed respond, the system will restart. But if not, the system will proceed to execute the loop.

Meanwhile, Figure 3(b) shows the assembled electrical hardware. Program starts to declare of all libraries and all variables for the programme used. Process continues to initialization serial communication, all input and output pins status, Wi-Fi network connection, and date and time data connection from network time protocol (NTP) service, then connecting to Firebase real-time database.

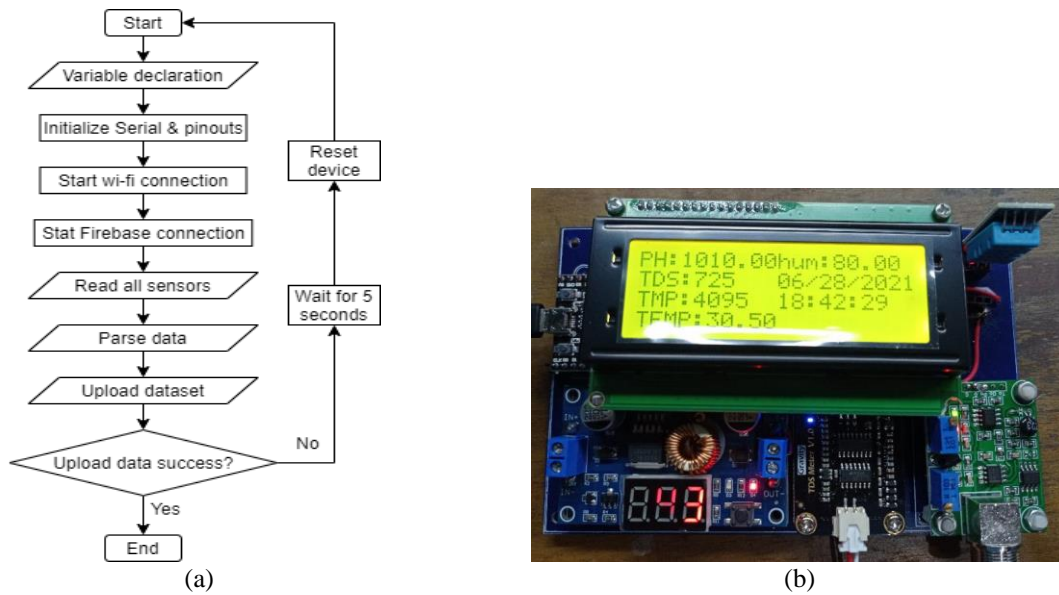

Figure 3. Program and hardware design of the system, (a) system program work flow diagram and (b) hardware device before calibration

2.4. Real-time database

The device of this research uses an open-source database provided by Google Firebase. The dataset is sent as JSON file then continuously synchronized to each dedicated client. The clients do not need to make a call to fetch data updates. Firebase will send a notification to the mobile application, every time the data is updated. Unless the dataset at database get updated, all response will be neglected to optimize the using of bandwidth. The feature of Google Firebase is a cloud-hosted database which put the dataset together from the ESP32, then deliver it to the database. The dataset forms as a string including the value of each sensor value separated by commas.

2.5. Android application

The Android application programmed using Android Studio software version 4.3. The integrated development environment (IDE) of Android Studio is created by Google. It offers tons of features for debugging, developing, and packaging an Android application. By using this IDE, the application can be developed for any Android device, or create an emulator virtual devices. The application for the monitoring device created with Java language. Application built as kind of native application. Native application are built specially for a mobile phone’s operating system (OS). Hence, this research use native Android mobile apps [29], [30].

2.6. Sensors calibration

The calibration process for all sensors needed to measure each character, which is accuracy, precision, and linearity. The first test is to calculate accuracy of each sensor. In terms of measurement activity, accuracy is the primary factor which influence the performance of a measuring instrument. Accuracy obtains how precise a measuring instrument to give a certain value [31]. This test done by comparing the output value of the sensor with the output value of standardized instrument. The comparison will result error calculated by (1).

$$Error = \left| \frac{Standart\ value - test\ value}{Standart\ value} \right| \tag{1}$$

The second test is knowing the precision of each sensor. The precision shows how a measuring instrument gives a certain scale value consistently at many times. This can be calculated from the standard deviation obtained from each test conducted. Standard deviation can be calculated by (2).

$$\sigma x = \sqrt{\frac{\sum_{i=1}^n (x_i - x)^2}{(n-1)}} \tag{2}$$

Then linearity is a mathematical relationship between input parameter and output parameter that can be represented as a straight line in a graphic [32]. Linearity is closely related to proportionality of input and output. Sensors calibrated on this monitoring device are; pH sensors, water temperature sensors, TDS sensors, also temperature and humidity sensor. This calibration process is also very important to be done to obtaining the regression equation. The equation is used to convert 12-bit analog values into actual unit values. Thus the regression equation for each sensor can be used as a reference in the calibration process for another monitoring devices.

3. IMPLEMENTATION

3.1. Field device system

The hardware of this monitoring device shown in Figure 4 is mounted near the hydroponic installation. The sensors used to measure the parameters of the condition of the water growing media are immersed in the water tank. The growing medium in this hydroponic farming system always flows under pressure from a water pump. The sensors used function to determine the condition and quality of hydroponic growing media.



Figure 4. The field device or monitoring hardware visualization

3.2. Android application for hydroponic farming (Arsenik)

Figure 5 shows the main application window presenting five essential parameters of the nutrient water in hydroponic system. The monitoring device hardware has provided an LCD to display the sensor reading. However, it only allows the user to do on-site inspection. To provide more flexibility in the water condition observation, an Android application is deployed for each Arsenik monitoring device. Thus, the user is now able to observe the system's condition remotely.



Figure 5. Android application user interface

3.3. Sensor calibration

This calibration process is carried out to determine the accuracy and precision of each sensor. Instruments calibrated on this monitoring device are pH sensors, water temperature sensors, TDS sensors, also temperature and humidity sensor. This calibration process is also very important to be done to obtaining the regression equation. The equation is used to convert 12-bit analog values into actual unit values. Thus the regression equation for each sensor can be used as a reference in the calibration process for another monitoring devices. The regression equation obtained by comparing the input value from ADC value and output value from standardized measurement. Sensors obtained the regression value are only pH and TDS. DS18B20 and DHT11 cannot be regressed because they are digital sensor. The equation for each sensor described:

$$pH = 11.5 - (0.0033 \times pH_{ADC_{value}}) \quad (4)$$

$$tds = (0.29 \times TDS_{ADC_{value}}) + 79 \quad (5)$$

where pH is true value of pH, $pH_{ADC_{value}}$ is ADC value input to pin 33 of ESP32, tds is true TDS value, and $TDS_{ADC_{value}}$ is ADC value input to pin 34 of ESP32.

4. RESULTS AND DISCUSSION

4.1. Sensors calibration analysis

Calibration process tested in this research are accuracy and precision. The precision is obtained with repeatability method. Tests are conducted to the same object, sensor device, standard measuring instrument, and done by the same measurement operator. Each test for each sensor is carried out 5 times, this is to test the precision. While the variation of testing for each sensor is carried out at different intervals and amounts. The pH sensor test was carried out on 3 variations of the buffer solution which had 3 different pH values at room temperature, namely; 4.01, 6.88, and 9.18. The comparison instrument for the pH test is PH818. TDS sensor testing is carried out on 5 different water temperature values, namely; 22.1, 24.3 °C, 25.5 °C, 37.2 °C, 44.6 °C, and 54.6 °C. The comparison instrument for the water temperature test is also the same, namely PH818, because this measuring instrument also has a water temperature measurement feature. Meanwhile, the TDS test was carried out on a number of 31 different variations of TDS values. The comparison instrument for the TDS test was the digital TDS-3 HM. While the comparison instrument for temperature and humidity is HTC-1. The results of testing all the sensors above are presented in Table 1.

In the dataset concluded in Table 1, all sensors have good accuracy. The pH sensor has insufficient accuracy and precision because the probe tip is not completely dried when changing the test buffer solution. The same thing also happened to the TDS test which used 5 variations of the solution with different levels of turbidity, sometimes the probe tip still had droplets from the previous solution. As for the water temperature test, the DS18B20 sensor has fairly good accuracy and precision, but has a rather long settling time, which is around 8-10 seconds. Likewise, the temperature and humidity readings by the DHT11 sensor also have fairly good accuracy and precision.

Table 1. Sensors accuracy and precision test result for the monitoring device

Sensor	Average error	Accuracy (%)	Standart deviation	Precision (%)
pH	17.8	82.2	49.4	50.6
TDS	8.2	91.8	6.1	93.9
Water temperature	3.4	96.6	3.6	96.4
Air temperature	2.6	97.4	4.8	95.2
Air humidity	1.3	98.7	4.9	95.1

4.2. Linearity

The linearity character can also determine the accuracy of the measurement. The higher the linearity value, the changes in the value received by the sensor will produce a more accurate output. In this research, linearity analysis was carried out on 3 sensors, namely, pH sensor, water temperature sensor, and TDS sensor. Figure 6 shows the linearity test results for the 3 sensors. From the test data, each result are; Figure 6(a) pH sensor has linearity of 95%, from Figure 6(b) shows that TDS sensor linearity is 99%, and from Figure 6(c) shows that water temperature DS18B20 sensor linearity is 95%. The linearity test results show that the 3 sensors have good linearity. This term will increase accuracy point.

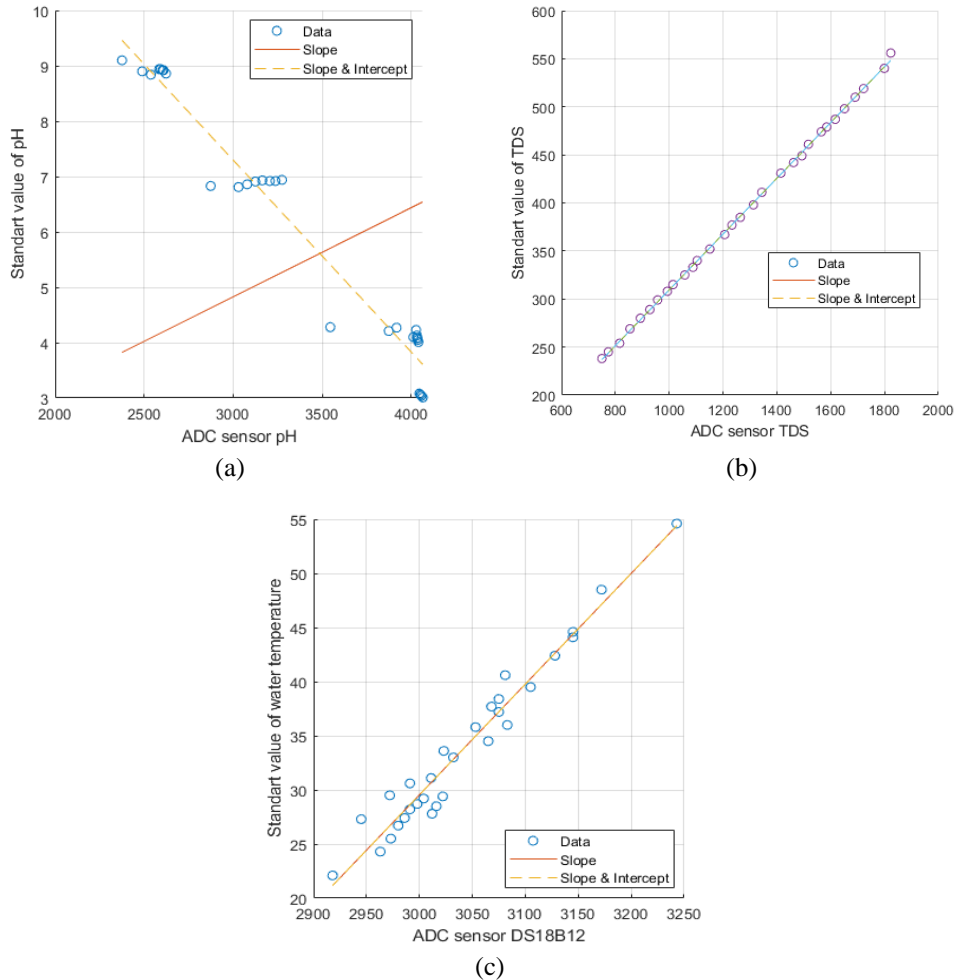

Figure 6. Linearity test results for; (a) pH sensor, (b) TDS sensor, and (c) DS18B20 sensor

4.3. Android application user interface (UI)

Android application testing is done by user survey. The number of respondents was 33 people with a student age range of 18-21 years as many as 16 people. In addition, the adult age range is 27-32 years as many as 17 people. The survey was conducted using the Google Form feature with the account of one of the researchers of all respondents, 77% said the UI design of the Arsenik application was attractive, 23% less attractive. In terms of informativeness, 84% said it was informative, while the remaining 16% said it was less informative. 100% of respondents can understand information about the pH value of water, water temperature, and air temperature well. While only 88% of respondents could understand the TDS value and humidity well, the remaining 12% did not understand the information. From the aspect of UI components testing was carried out on several components namely background color, layout, font, font size, parameter value, parameter description, and logos. Of the 33 respondents, 55.6% stated that they did not agree with the background color, 33.3% questioned the layout form, and the remaining 11.1% questioned the parameter units.

5. CONCLUSION

From the whole process of designing and manufacturing hydroponic growing media monitoring devices, it can be concluded that this IoT-based monitoring system has been running well. The design from the hardware side shows that the system has been able to be implemented into a hydroponic farming system with a maximum power supply of 36 V and current consumption of 110 mA. From the firmware side, the program embedded in the ESP32 can also carry out the tasks of capturing sensor data, processing data, internet connection, and updating data with Google Firebase well. Then from the user's side, the Android application created also has a fairly high value of interest and informativeness. This allows hydroponic

farmers to use this Arsenic monitoring device well so that they can run the hydroponic farming system more optimally. Testing the sensors showed good results. The three sensors of pH, TDS, and water temperature have good linearity, which are 95%, 99%, and 95%, respectively. In terms of accuracy, only the pH sensor has an accuracy rate below 90%, while the four sensors have accuracy above 90%. Precision testing also shows the same thing, that the pH sensor also has shortcomings in terms of the level of precision which is below 90%. This is different from other sensors that have a precision level of more than 90%.

ACKNOWLEDGEMENTS

This research was supported by the Faculty of Advanced Technology and Multidiscipline (FTMM) and Research and Community Services Institution (LPPM), Universitas Airlangga as a part of the community service program in 2021. We are also grateful for community members and Hidroponikkoe farmers from Karangploso Village, Pasuruan, Indonesia as kind partners to conduct this program successfully.



REFERENCES

- [1] A. N. Harun, N. Mohamed, R. Ahmad, A. R. A. Rahim, and N. N. Ani, "Improved internet of things (IoT) monitoring system for growth optimization of Brassica chinensis," *Comput. Electron. Agric.*, vol. 164, no. March, p. 104836, 2019, doi: 10.1016/j.compag.2019.05.045.
- [2] A. R. Yanes, P. Martinez, and R. Ahmad, "Towards automated aquaponics: A review on monitoring, IoT, and smart systems," *J. Clean. Prod.*, vol. 263, p. 121571, 2020, doi: 10.1016/j.jclepro.2020.121571.
- [3] A. Shrivastava, C. K. Nayak, R. Dilip, S. R. Samal, S. Rout, and S. M. Ashfaque, "Automatic robotic system design and development for vertical hydroponic farming using IoT and big data analysis," in *Mater. Today Proc.*, 2021, doi: 10.1016/j.matpr.2021.07.294.
- [4] M. Mehra, S. Saxena, S. Sankaranarayanan, R. J. Tom, and M. Veeramanikandan, "IoT based hydroponics system using deep neural networks," *Comput. Electron. Agric.*, vol. 155, no. August, pp. 473–486, 2018, doi: 10.1016/j.compag.2018.10.015.
- [5] P. N. Crisnapati, I. N. K. Wardana, I. K. A. A. Aryanto, and A. Hermawan, "Hommons: hydroponic management and monitoring system for an IoT based NFT farm using web technology," in *2017 5th Int. Conf. Cyber IT Serv. Manag. CITSM 2017*, 2017, doi: 10.1109/CITSM.2017.8089268.
- [6] R. B. Lukito and C. Lukito, "Development of IoT at hydroponic system using raspberry Pi," *Telkomnika (Telecommunication Comput. Electron. Control)*, vol. 17, no. 2, pp. 897–906, 2019, doi: 10.12928/TELKOMNIKA.V17I2.9265.
- [7] M. N. Halgamuge, A. Bojovschi, P. M. J. Fisher, T. C. Le, S. Adeloju, and S. Murphy, "Internet of things and autonomous control for vertical cultivation walls towards smart food growing: A review," *Urban For. Urban Green.*, vol. 61, no. March, 2021, doi: 10.1016/j.ufug.2021.127094.
- [8] E. R. Kaburuan, R. Jayadi, and Harisno, "A design of IoT-based monitoring system for intelligence indoor micro-climate horticulture farming in Indonesia," *Procedia Comput. Sci.*, vol. 157, pp. 459–464, 2019, doi: 10.1016/j.procs.2019.09.001.
- [9] R. Lakshmanan, M. Djama, S. K. Selvaperumal, and R. Abdulla, "Automated smart hydroponics system using internet of things," *Int. J. Electr. Comput. Eng.*, vol. 10, no. 6, pp. 6389–6398, 2020, doi: 10.11591/IJECE.V10I6.PP6389-6398.
- [10] S. Puengsungwan and K. Jirasereeamornkul, "Internet of things (IoT) based hydroponic lettuce farming with solar panels," in *Proc. 2019 Int. Conf. Power, Energy Innov. ICPEI 2019*, vol. 765, pp. 86–89, 2019, doi: 10.1109/ICPEI47862.2019.8944986.
- [11] V. P. Prabha, S. M. Sarala, and C. S. Suttur, "Robust smart irrigation system using hydroponic farming based on data science and IoT," in *Proc. B-HTC 2020 - 1st IEEE Bangalore Humanit. Technol. Conf.*, 2020, doi: 10.1109/B-HTC50970.2020.9297842.
- [12] H. Andrianto, Suhardi, and A. Faizal, "Development of smart greenhouse system for hydroponic agriculture," in *2020 Int. Conf. Inf. Technol. Syst. Innov. ICITSI 2020 - Proc.*, 2020, pp. 335–340, doi: 10.1109/ICITSI50517.2020.9264917.
- [13] M. F. Saaid, A. I. M. Yassin, and N. M. Tahir, "Automated monitoring and controlling pH levels for hydroponics cultivation technique," *Indonesian Journal of Electrical Engineering and Computer Science (IJECS)*, vol. 18, no. 3, pp. 1236–1243, 2020, doi: 10.11591/ijeecs.v18.i3.pp1236-1243.
- [14] J. Chaiwongsai, "Automatic control and management system for tropical hydroponic cultivation," in *Proc. - IEEE Int. Symp. Circuits Syst.*, vol. 2019-May, pp. 2019–2022, 2019, doi: 10.1109/ISCAS.2019.8702572.
- [15] V. Palande, A. Zaheer, and K. George, "Fully automated hydroponic system for indoor plant growth," *Procedia Comput. Sci.*, vol. 129, pp. 482–488, 2018, doi: 10.1016/j.procs.2018.03.028.
- [16] D. Glaroudis, A. Iossifides, and P. Chatzimisios, "Survey, comparison and research challenges of IoT application protocols for smart farming," *Comput. Networks*, vol. 168, p. 107037, 2020, doi: 10.1016/j.comnet.2019.107037.
- [17] T. Hariono and M. C. Putra, "Data acquisition for monitoring IoT-based hydroponic automation system using ESP8266," vol. 1, no. 1, 2021.
- [18] S. Pawar, S. Tembe, and S. Khan, "Design of an affordable pH module for IoT Based pH level control in hydroponics applications," in *2020 Int. Conf. Conver. to Digit. World - Quo Vadis, ICCDW 2020*, 2020, doi: 10.1109/ICCDW45521.2020.9318677.
- [19] S. Zhang *et al.*, "Investigation on environment monitoring system for a combination of hydroponics and aquaculture in greenhouse," *Inf. Process. Agric.*, 2021, doi: 10.1016/j.inpa.2021.06.006.
- [20] D. Eridani, O. Wardhani, and E. D. Widiyanto, "Designing and implementing the arduino-based nutrition feeding automation system of a prototype scaled nutrient film technique (NFT) hydroponics using total dissolved solids (TDS) sensor," in *Proc. - 2017 4th Int. Conf. Inf. Technol. Comput. Electr. Eng. ICITACEE 2017*, vol. 2018-Janua, pp. 170–175, 2017, doi: 10.1109/ICITACEE.2017.8257697.
- [21] F. M. Sharmila, P. Suryaganesh, M. Abishek, and U. Benny, "IoT based smart window using sensor Dht11," in *2019 5th Int. Conf. Adv. Comput. Commun. Syst. ICACCS 2019*, 2019, pp. 782–784, doi: 10.1109/ICACCS.2019.8728426.
- [22] P. F. Dheena, G. S. Raj, G. Dutt, and S. V. Jinny, "IoT based smart street light management system," in *2017 IEEE international conference on circuits and systems (ICCS)*, 2018, vol. 2018-Janua, pp. 368–371, doi: 10.1109/ICCS1.2017.8326023.
- [23] A. G. Shabeeb, A. J. Al-Askery, and Z. M. Nahi, "Remote monitoring of a premature infants incubator," *Indonesian Journal of Electrical Engineering and Computer Science (IJECS)*, vol. 17, no. 3, pp. 1232–1238, 2019, doi: 10.11591/ijeecs.v17.i3.pp1232-1238.



- [24] P. Megantoro, S. A. Aldhama, and G. S. Prihandana, "IoT-based weather station with air quality measurement using ESP32 for environmental aerial condition study," *TELKOMNIKA (Telecommunication, Computing, Electronics and Control)*, vol. 18, no. 1, pp. 1–9, 2020, doi: 10.12928/telkomnika.v19i4.18990.
- [25] P. Megantoro, B. A. Pramudita, P. Vigneshwaran, A. Yurianta, and H. A. Winarno, "Real-time monitoring system for weather and air pollutant measurement with HTML-based UI application," *Bulletin of Electrical Engineering and Informatics (BEEI)*, vol. 10, no. 3, pp. 1669–1677, 2021, doi: 10.11591/eei.v10i3.3030.
- [26] P. Foltýnek, M. Babiuch, and P. Šuránek, "Measurement and data processing from Internet of things modules by dual-core application using ESP32 board," *Meas. Control (United Kingdom)*, vol. 52, pp. 970–984, 2019, doi: 10.1177/0020294019857748.
- [27] M. E. Moulat, O. Debauche, A. Lahcen, M. E. Moulat, O. Manneback, and A. Lahcen, "Monitoring system using internet of things for potential landslides," *Procedia Computer Science*, vol. 134, pp. 26–34, 2018, doi: 10.1016/j.procs.2018.07.140.
- [28] A. H. Ali, A. H. Duhis, N. A. L. Alzurfi, and M. J. Mnati, "Smart monitoring system for pressure regulator based on IoT," *International Journal of Electrical and Computer Engineering (IJECE)*, vol. 9, no. 5, pp. 3450–3456, 2019, doi: 10.11591/ijece.v9i5.pp3450-3456.
- [29] R. Asritha and R. Arpitha, "A survey paper on introduction to android and development process," *Int. Res. J. Eng. Technol.*, vol. 07, no. June, pp. 2753–2756, 2020.
- [30] N. Verma, S. Kansal, and H. Malvi, "Development of native mobile application using android studio for cabs and some glimpse of cross platform apps," *Int. J. Appl. Eng. Res.*, vol. 13, no. 16, pp. 12527–12530, 2018.
- [31] P. Megantoro, A. Latif, B. A. Pramudita, and P. Vigneshwaran, "Automatic limit switch calibrator for control valve at steam turbine of a geothermal power plant," *Bulletin of Electrical Engineering and Informatics (BEEI)*, vol. 10, no. 3, pp. 1245–1251, 2021, doi: 10.11591/eei.v10i3.3031.
- [32] K. V. Santhosh and B. K. Roy, "An adaptive calibration circuit for RTD using optimized ANN," in *7th Int. Conf. Intell. Syst. Control. ISCO 2013*, no. November 2015, pp. 49–54, 2013, doi: 10.1109/ISCO.2013.6481121.

BIOGRAPHIES OF AUTHORS





Prisma Megantoro    is a lecturer in Electrical Engineering, Faculty of Advanced Technology, and Multidiscipline Universitas Airlangga since 2020. He received a bachelor's degree and master's degree from Universitas Gadjah Mada, Yogyakarta, Indonesia in 2014 and 2018. His current research is focused on solar photovoltaic technology, embedded system, and the internet of things. He can be contacted at email: prisma.megantoro@ftmm.unair.ac.id





Rizki Putra Prastio    is a lecturer in Robotics and Artificial Intelligence Engineering, Airlangga University since 2020. He earned his bachelor's degree in physics from Airlangga University in 2013 and finished his master's degree in electrical engineering from Bandung Institute Technology in 2016. His research interests including image processing, radar, computer vision, biomedical instrumentation, and machine learning. He can be contacted at email: r.p.prastio@ftmm.unair.ac.id.





Hafidz Faqih Aldi Kusuma    was born in Surabaya, Indonesia in 2000, after graduating from high school. He continued his studies at the Institut Teknologi Sepuluh Nopember majoring in Information and Applied Computer Education in 2018 with a study period of one year. Then, continued his studies in electrical engineering at Airlangga University in 2020. Now, he is active in the robotics community of the flying robot division and he is also active in the instrumentation research group. He can be contacted at email: hafidz.faqih.aldi-2020@ftmm.unair.ac.id.





Abdul abrор    was born in 10 October 2002. After graduating from high school he continued his study at Airlangga University majoring in electrical engineering in 2020. Now he is active in the robotics community of the soccer robot division, Mikrotik networking community, cisco networking community and also he is active in the instrumentation research group. He can be contacted at email: abdul.abror-2020@stmm.unair.ac.id.





Pandi Vigneshwaran    has obtained his Doctoral Degree in Anna University Chennai during 2016 and Master of Engineering under Anna University Chennai during June 2005. He is having 18.4 years of experience and specialization in Cybersecurity. Presently, He is working as Associate Professor in SRM Institute of Science and Technology, Chennai. He has published more than 18 papers in various International journals and 5 in International Conferences. His area of interest includes Security, Routing, and Intelligent Data Analysis. He can be contacted at email: vigenesp@srmist.edu.in.



Dimas Febriyan Priyambodo    is a lecturer in Polteknik Siber dan Sandi Negara, Bogor Indonesia. He obtained his master degree at Computer Science of Universitas Gadjah Mada at 2018. His research are in the field of multicore server and cyber security. He can be contacted at email: dimas.febriyan@poltekssn.ac.id.



Diaz Samsun Alif    was born in Jombang, East Java, Indonesia in 2001, after graduating from Vocational High School, he continued his studies at Airlangga University majoring in Electrical Engineering in 2020. He is now active in the robotics community, the thematic robot division, and is also active in the instrumentation research group. He can be contacted at email: diaz.samsun.alif-2020@stmm.unair.ac.id.