

Assessment study of STATCOM's effectiveness in improving transient stability for power system

Le Ngoc Giang*, Nguyen Thi Dieu Thuy, Tran Thi Ngoat

School of Electrical Engineering, Wuhan University
Luo-jia-shan Wuchang, Wuhan, Hubei Province, PR China, post code: 430072
*Corresponding author, e-mail: lengocgianglinh@gmail.com

Abstract

Many of papers refers to study of application for FACTS. Especially for using reactive compensators for 500KV power system in order to increase the static voltage stability margin and transient stability enhancement have considered. However the selections of suitable VAR source (STATCOM or SVC) also need to be considered. The purpose of this paper is to solve the above problems in order to suggest a solution of the appropriate shunt compensator for a reality 500KV power system. All the simulations for the above work have been carried out using MATLAB-SIMULINK environment.

Keywords: FACTS, SVC, STATCOM, Transient Stability of Power System.

Copyright © 2013 Universitas Ahmad Dahlan. All rights reserved.

1. Introduction

Power systems components mainly consist of generators, transmission lines, transformers, switches, active or passive compensators and loads. Power system networks are complex systems that are nonlinear, non-stationary, prone to disturbances and faults.

In recent years, The electrical power system is continuously expanding in size and growing complexity all over the world. The electricity industry has undergone several changes due to privatization all over the world which has affected power system management and energy markets [1]. The power system which are heavily loaded, faulted and having shortage of reactive power are the main reason for voltage collapse [2]. As the voltage collapse problem is closely related to reactive power planning including the contingency analysis, as these should be considered for the secure operation of the power system [3]. During the outage conditions of some critical lines, the generators are capable of supplying limited reactive power even sometimes the supplied reactive power cannot be used to fulfill the requirement of the network because the location is far from the generator point. Further, the real powers of the generators are reduced to supply the reactive power demand of the system. Hence, the reactive power compensators are used to maintain the voltage profile and there by improving the performances of the system [4].

Voltage collapse studies are of growing importance for the design and operation of power systems. The main function of shunt reactive power compensation is for voltage support to avoid voltage collapse. Then, voltage stability is a very important Consideration, when the location and size of new Var sources need to be determined during Var planning. Many analytical methodologies have been proposed and are currently used for the study of this problem.

Flexible Alternating Current Transmission Systems (FACTS) devices are being very popular for improving overall performance of the power system. FACTS devices are the solid state converters having capability of improving power transmission capacity, voltage profile, enhancing power system stability and security [5].

FACTS based equipment, provide proven technical solutions to voltage stability problems. Especially, due to the increasing need for fast response for power quality and voltage stability, the shunt dynamic Var compensators such as Static Var Compensators (SVC) and Static Synchronous Compensators (STATCOM) have become feasible alternatives to a fixed reactive source, and therefore have received intensive interests [6], [7].

This paper focuses on the placement and selection of suitable Var source (STATCOM or SVC), for improving the voltage profile and reducing the real power losses for a reality 500KV power system. SVC and STATCOM is shunt FACTS devices which is designed to maintain the voltage profile in a power system under normal and contingency conditions. In practical power systems, all buses have different sensitivity to the power system security and stability. If SVC and STATCOM is allocated at more sensitive buses, it will effectively improve the voltage profiles and stability.

2. FACTS Devices

In the late 1980s, the Electric Power Research Institute (EPRI) formulated the vision of the FACTS in which various power-electronics based controllers regulate power flow and transmission voltage and mitigate dynamic disturbances. Generally, the main objectives of FACTS are to increase the useable transmission capacity of lines and control power flow over designated transmission routes. Hingorani and Gyugyi [8] and Hingorani [9] proposed the concept of FACTS. There are two generations for realization of power electronics-based FACTS controllers: the first generation employs conventional thyristor-switched capacitors and reactors, the second generation employs gate turn-off (GTO) thyristor-switched converters as voltage source converters (VSCs). The first generation has resulted in the SVC, the Thyristor-Controlled Series Capacitor (TCSC), and the Thyristor-Controlled Phase Shifter (TCPS) [10], [11]. The second generation has produced the STATCOM, the Static Synchronous Series Compensator (SSSC), the Unified Power Flow Controller (UPFC), and the Interline Power Flow Controller (IPFC) [12], [13]. The two groups of FACTS controllers have distinctly different operating and performance characteristics. The VSC type FACTS controller group employs self-commutated DC to AC converters, using GTO thyristors, which can internally generate capacitive and inductive reactive power for transmission line compensation, without the use of capacitor or reactor banks. The converter with energy storage device can also exchange real power with the system, in addition to the independently controllable reactive power. The VSC can be used uniformly to control transmission line voltage, impedance, and angle by providing reactive shunt compensation, series compensation, and phase shifting, or to control directly the real and reactive power flow in the line [14], [15]. SVC and STATCOM are the shunt devices of the FACTS family using power electronics to control power flow and improve transient stability on power grids [16], [17] to regulate voltage at its terminals by controlling the amount of reactive power injected into or absorbed from the power system. When system voltage is low, they generate reactive power (capacitive). When system voltage is high, it absorbs reactive power (inductive).

2.1. Static VAR Compensator (SVC)

Typically, an SVC comprises one or more banks of fixed or switched shunt capacitors or reactors, of which at least one bank is switched by thyristors. Elements which may be used to make an SVC typically include: Thyristor controlled reactor (TCR), where the reactor may be air- or iron-cored. Thyristor switched capacitor (TSC). Harmonic filter(s). Mechanically switched capacitors or reactors (switched by a circuit breaker).

One-line diagram of a typical SVC configuration; here employing a thyristor controlled reactor, a thyristor switched capacitor, a harmonic filter, a mechanically switched capacitor and a mechanically switched reactor.

The SVC can be operated in two different modes:

- In voltage regulation mode (the voltage is regulated within limits)
- In VAR control mode (the SVC susceptance is kept constant)

When the SVC is operated in voltage regulation mode, it implements the following V-I characteristic. As long as the SVC susceptance B stays within the maximum and minimum susceptance values imposed by the total reactive power of capacitor banks (B_{cmax}) and reactor banks (B_{lmax}), the voltage is regulated at the reference voltage V_{ref} . However, a voltage droop is normally used (usually between 1% and 4% at maximum reactive power output), and the V-I characteristic has the slope indicated in the figure. The V-I characteristic is described by the following three equations:

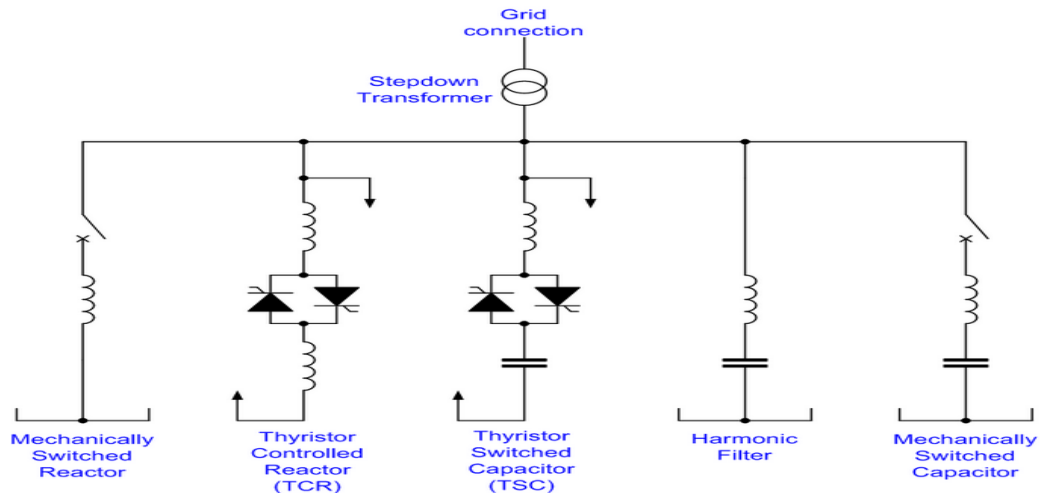

Figure 1. One-line diagram of a typical SVC configuration

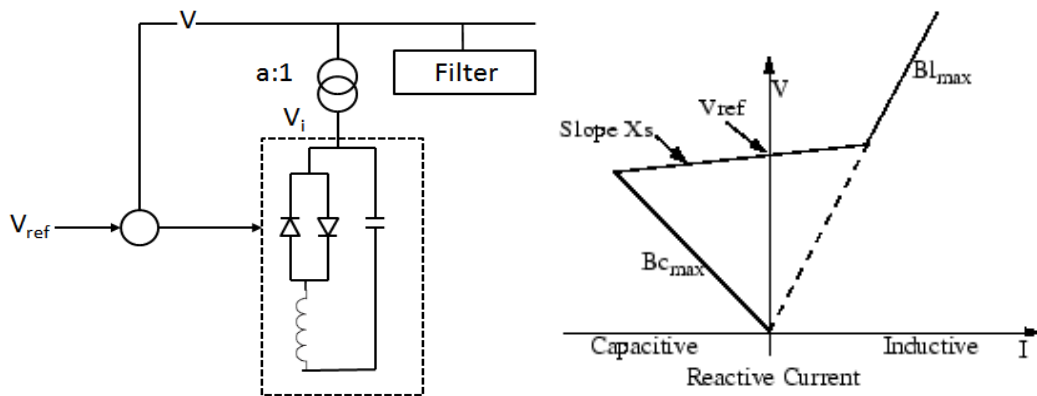

Figure 2. (a) Basic structure of SVC, (b) terminal characteristic of SVC.

$$V = V_{ref} + X_s \cdot I \quad \text{SVC is in regulation range } (-B_{cmax} < B < B_{lmax})$$

$$V = -\frac{I}{B_{cmax}} \quad \text{SVC is fully capacitive } (B = B_{cmax})$$

$$V = \frac{I}{B_{lmax}} \quad \text{SVC is fully inductive } (B = B_{lmax})$$

Where

V Positive sequence voltage (pu)

I Reactive current (pu/Pbase) ($I > 0$ indicates an inductive current)

X_s Slope or droop reactance (pu/Pbase)

B_{cmax} Maximum capacitive susceptance (pu/Pbase) with all TSCs in service, no TSR or TCR

B_{lmax} Maximum inductive susceptance (pu/Pbase) with all TSRs in service or TCRs at full conduction, no TSC

Pbase Three-phase base power specified in the block dialog box

2.2. Static Compensator (STATCOM)

The variation of reactive power is performed by means of a VSC connected on the secondary side of a coupling transformer. The VSC uses forced-commutated power electronic devices (GTOs, IGBTs or IGCTs) to synthesize a voltage V2 from a DC voltage source. The principle of operation of the STATCOM is explained on the figure below showing the active and reactive power transfer between a source V1 and a source V2. In this figure, V1 represents the system voltage to be controlled and V2 is the voltage generated by the VSC.

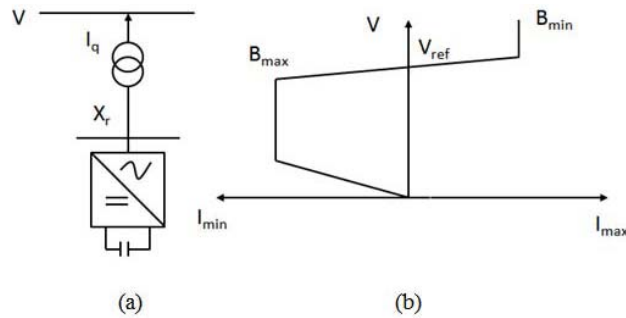

Figure 3. (a) Basic Structure of STATCOM, (b) terminal characteristic of STATCOM.

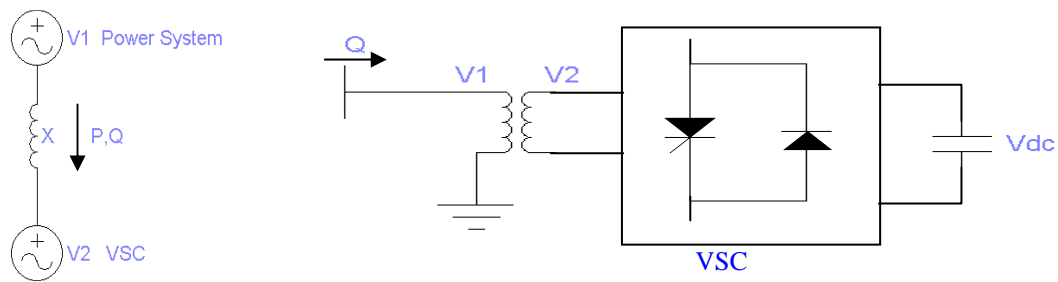

Figure 4. Operating Principle of the STATCOM

$$P = \frac{V_1 V_2 \sin \delta}{X}$$

$$Q = \frac{V_1(V_1 - V_2 \cos \delta)}{X}$$

where:

- V₁ line to line Voltage of source V₁
- V₂ line to line Voltage V₂
- X Reactance of interconnection transformer and filter
- δ angle of V₁ with respect to V₂

In steady state operation, the voltage V2 generated by the VSC is in phase with V1 (δ=0), so that only reactive power is flowing (P=0). If V2 is lower than V1, Q is flowing (will flow) from V1 to V2 (STATCOM is absorbing reactive power). On the reverse, if V2 is higher than V1, Q is flowing (will flow) from V2 to V1 (STATCOM is generating reactive power). The STATCOM regulates system voltage by absorbing or generating reactive power, STATCOM output current (inductive or capacitive) can be controlled independent of the AC system voltage.

3. Results and Analysis

3.1. Circuit Description

Figure 5 shows the 3-Bus system used in the study. The power grid consists of two voltage sources 500kV, frequency 60Hz (1200 MVA and 1500 MVA respectively) connected by

transmission lines: L1=90km, L2=65km, L3=75km. Load 1: Three-Phase Load P1=55 MW. Load 2: Three-Phase Load P2= 45 MW. Load 3: Three-Phase Load P3= 800 MW, Q3 = 200MVar.

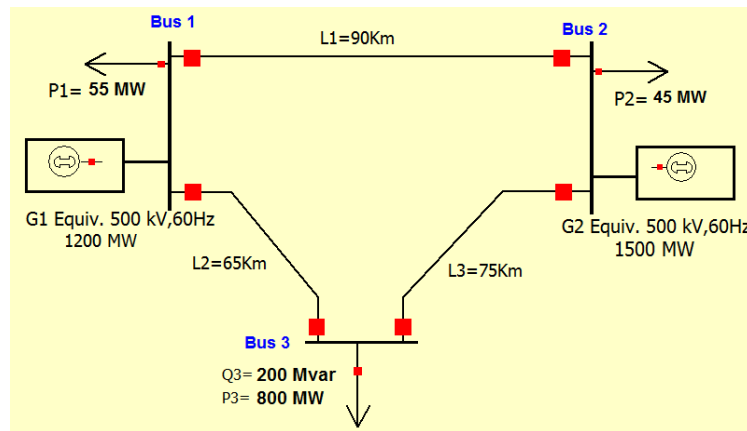

Figure 5. MODEL of Power transmission system

The load 3 the active power and the reactive power are 800MW and 200MVAR respectively. The percentages of load 3 are 25%, 50%, 75% and 100% in the operation. load 3 in 25% mode: P325= 200 MW, Q325 = 50MVAR. load 3 in 50% mode: P350= 400 MW, Q350 = 100MVAR. load 3 in 75% mode: P375= 600 MW, Q375 = 150MVAR. load 3 in 100% mode: P3=800 MW, Q3 = 200MVAR.

Table 1. Voltages on the bus of the power system

V1(pu)			V2(pu)				V3(pu)			
25%	50%	75%	25%	50%	75%	100%	25%	50%	75%	100%
1.065	1.021	0.9747	1.064	1.021	0.975	0.9298	1.066	1.018	0.9692	0.9208

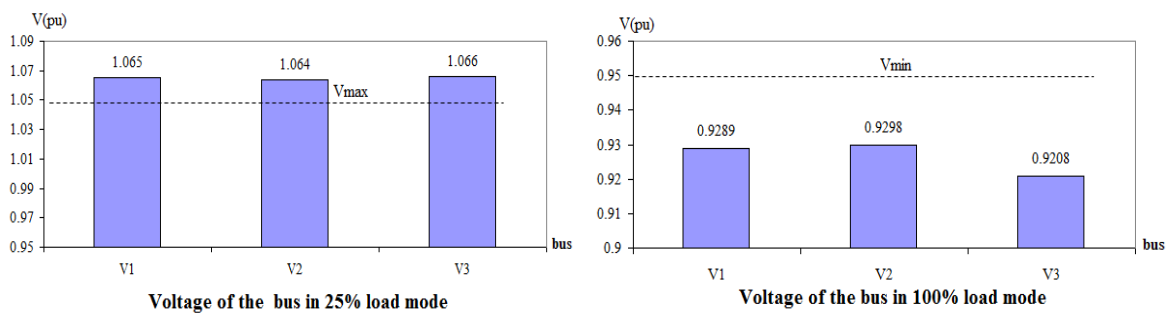

Figure 6. Voltage of the bus in 25% and 100% load mode

When STATCOM and SVC are not in the operation, load 3 in 25% mode and 100% mode, V of the 3 bus are outside the specified limits [95%, 105%]. Especially in bus 3 the load voltage are 1.066pu and 0.9208pu in proportion to 25% and 100% load respectively.

To analyze and compare the efficiency of SVC and STATCOM for the enhancement of the power system stability, we consider SVC and STATCOM on the transmission line of power system, shown in Figure 7.

The figure 7 shown above is model of the transmission line with STATCOM installed in bus B3, and has a rating of +/- 100MVA. This STATCOM has a DC link nominal voltage of 40 kV with an equivalent capacitance of 375 uF. On the AC side, its total equivalent impedance is

0.22 pu on 100 MVA. This impedance represents the transformer leakage reactance and the phase reactor of the IGBT bridge of an actual PWM STATCOM.

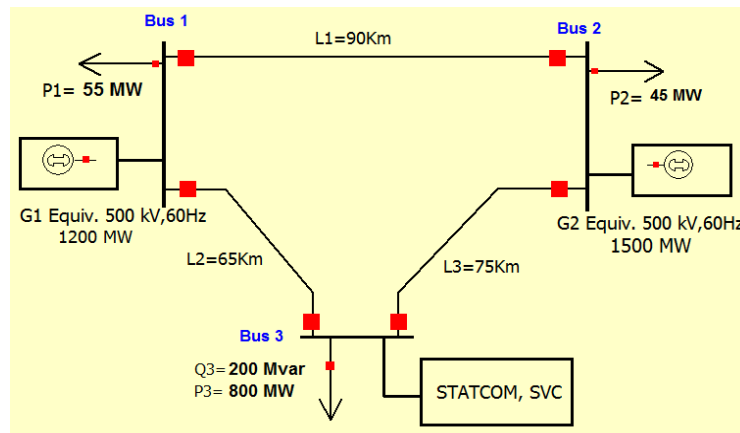

Figure 7. MODEL of Power transmission system with STATCOM, SVC

3.2. The obtained results

The obtained results with and without the compensation of the reactive power were tabulated in Table 1, 2 and 3. When STATCOM and SVC are connected, the load Voltage has increased.

Table 2. Comparison of voltage regulation when SVC and STATCOM are connected

V	V1				V2				V3			
	25%	50%	75%	100%	25%	50%	75%	100%	25%	50%	75%	100%
Without	1.065	1.021	0.97.47	0.9289	1.064	1.021	0.975	0.9298	1.066	1.018	0.9692	0.9208
SVC	1.031	1.011	0.9887	0.957	1.031	1.011	0.9898	0.9597	1.027	1.008	0.9863	0.9536
Statcom	1.021	1.001	0.9897	0.9589	1.021	1.001	0.9898	0.9591	1.022	1.003	0.9868	0.955

Table 3. Comparison of real power transferred when SVC and STATCOM are connected

P	P1				P2				P3			
	25%	50%	75%	100%	25%	50%	75%	100%	25%	50%	75%	100%
Without	90.62	175.8	243.9	296.5	137	239.5	321	383.8	227.4	414.7	563.7	678.3
SVC	84.05	172.2	252.5	318	127.1	234.6	332.4	411.5	211	406.2	583.7	727.5
Statcom	84.31	172.2	252.6	319.3	127.5	234.7	332.5	413.2	211.6	406.3	583.8	730.4

Table 4. Comparison of reactive power transferred when SVC and STATCOM are connected

Q	Q1				Q2				Q3			
	25%	50%	75%	100%	25%	50%	75%	100%	25%	50%	75%	100%
Without	-114.1	-77.87	-47.05	-18.97	-140.6	-96.68	-56.76	-21.32	56.85	103.7	140.9	169.6
SVC	-64.87	-65.72	-68.66	-60.67	-80.25	-80.57	-83.21	-72.32	145.6	127.6	100.9	90.93
Statcom	-64.9	-65.73	-68.67	-62.73	-80.28	-80.58	-83.22	-74.83	145.5	127.6	100.8	86.91

Table 2, 3, 4 and Figure 8 show that, when SVC and STATCOM devices are entered in the operation, it has regulated the voltage in the allowed limit. Figure 9. Illustrate the Voltage and reactive power of 100% load without the compensation.

Figure 10 and 11 show that the voltage regulation and reactive power generate or absorb when STATCOM & SVC devices are connected in cases the percentage load are 25% and 100% respectively. Through which we see, voltage is controlled better when without STATCOM & SVC.

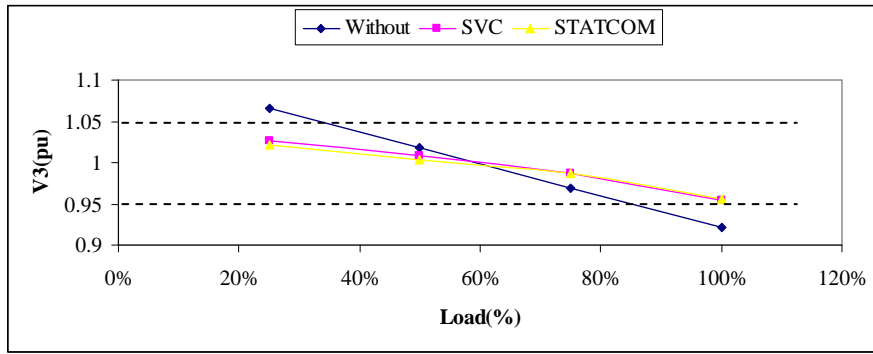

Figure 8. Voltage regulation with and without the compensation

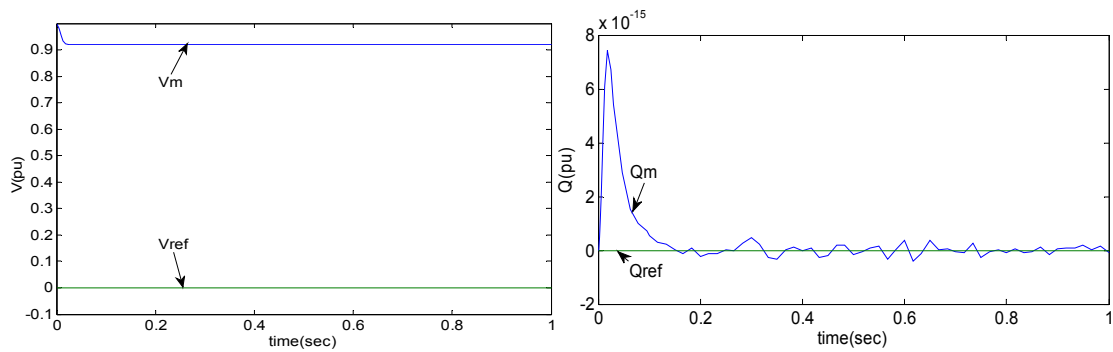

Figure 9. Voltage & reactive power of 100% load without the compensation

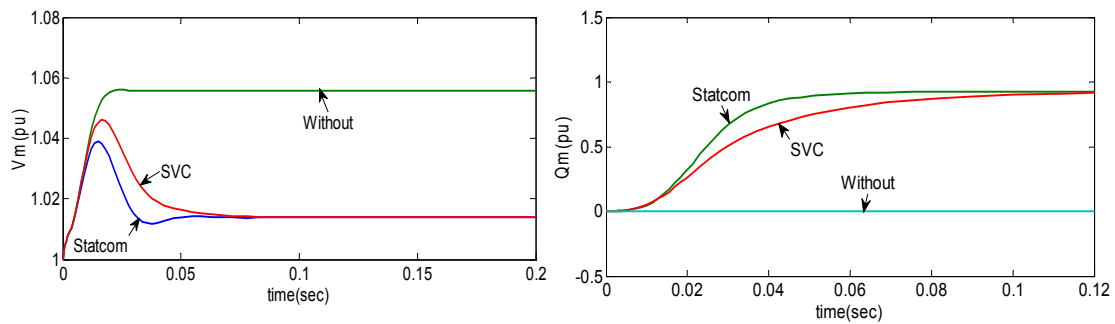

Figure 10. Voltage & Reactive power at load mode 25% with and without STATCOM & SVC

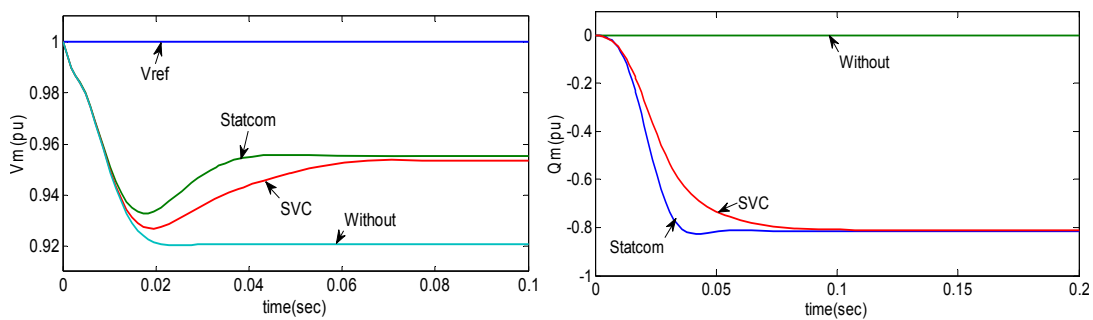

Figure 11. Voltage & Reactive power at load mode 100% with and without STATCOM & SVC

3.3. The Fault Appears

When the ground fault phase A appears, if without compensation the voltage will be 0.6371pu. In contrast, if with STATCOM exists, the reactive power is - 0.6612pu, at that time voltage reached to 0.6632pu. With SVC the reactive power is - 0.4303pu, at that time voltage reached to 0.6546pu.

Figure 12 show the change of voltage & reactive power when ground fault phase A appear with and without the compensation

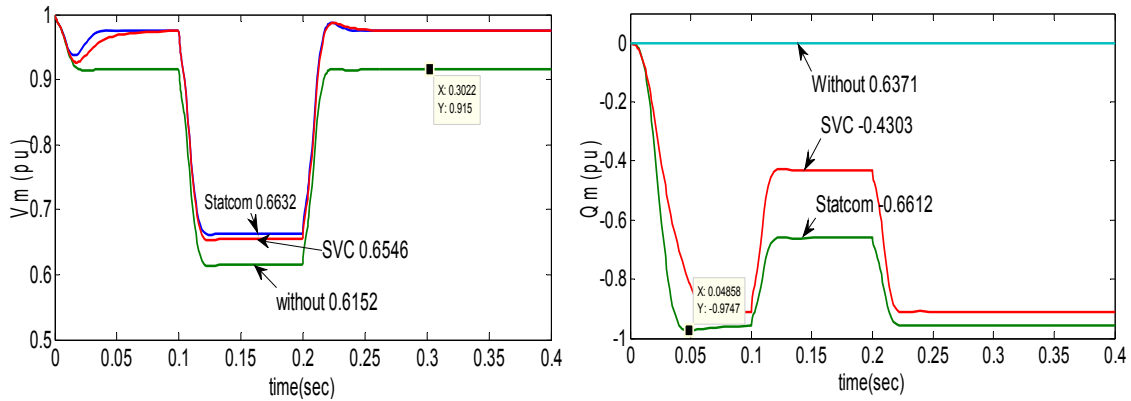

Figure 12. Voltage & Reactive power when the ground fault phase A appears, with and without the compensation

Applying the same analysis as above, when ground fault two phases A&B appear. At that time, the effects of STATCOM will be better than these of SVC.

Figure 13 show that voltage and reactive power when ground fault two phases A, B appear with and without the compensation.

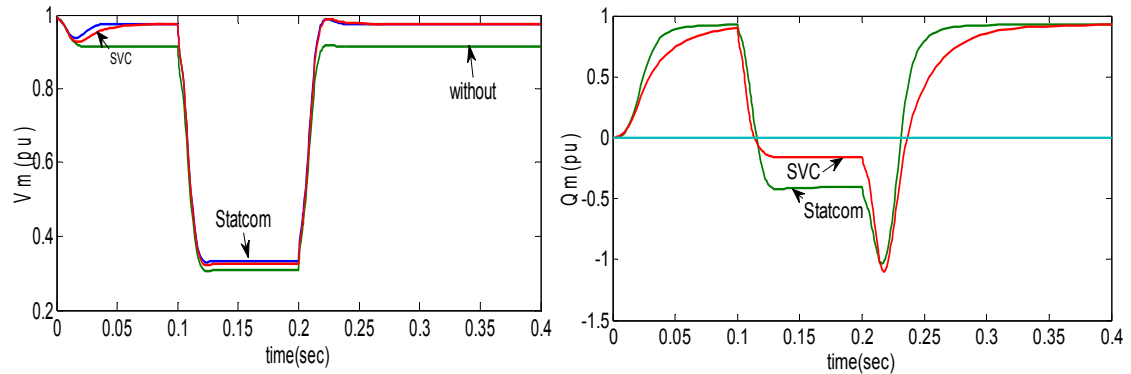

Figure 13. Voltage & Reactive power when the ground fault phase A&B appears, with and without the compensation

Figure 14 compare the effects between STATCOM and SVC under the condition when the three-phase of Breaker Fault appear in $t = 0.1s$ to $t = 0.2s$.

The results of Researched model indicated that STATCOM and SVC are very useful in improving the transient stability, Voltage profile & power flow, as well as in providing the system a faster & steadier state achievement. Simulation results show the effectiveness of SVC and STATCOM in controlling the real and reactive power. Besides, STATCOM reacts faster and provides good effects to stabilize electric system, especially when faults appear.

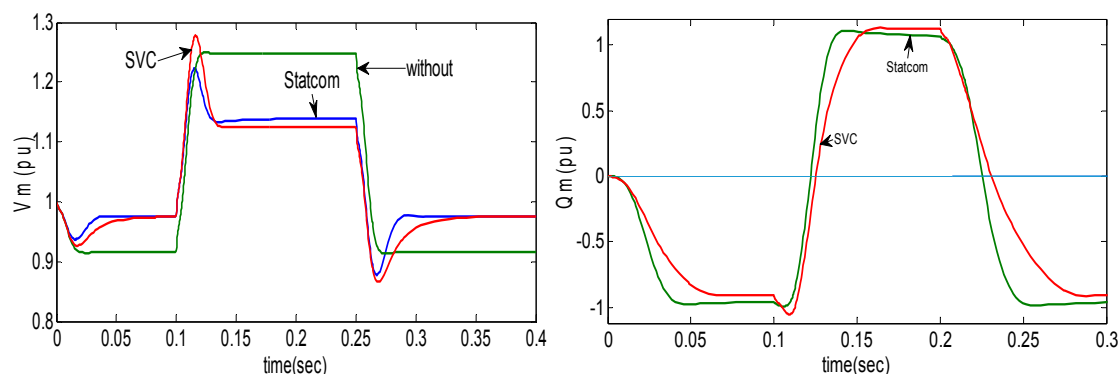

Figure 14. Voltage & Reactive power when three-phase of Breaker Fault

4. Conclusion

In this study, the power system stability enhancement via STATCOM and SVC stabilizers is presented and discussed. An effort is made to assess voltage stability and security of multi-bus power system in presence of STATCOM and SVC. A comparative study on effectiveness of STATCOM and SVC in improvement of voltage stability and security has also been presented. STATCOM is found to be more effective than SVC to ensure voltage stability and security, at the same time, it is also capable to considerably reduce reactive power line loss. The results of this work are of certain practical significance and applicable value.

References

- [1] CA Canizares. Applications of Optimization to Voltage Collapse Analysis. *IEEE IPES Summer Meeting*, San Diego; 1998.
- [2] P Kundur, 1 Paserba, V Ajarapu, G Anderson, A Bose, CA Canizares, N Hatziaig Yfiou, D Hill, A Stankovic, C Taylor, T Van Cutsem, and V Vittal. Definition and Classification of Power System Instability. *IEEE Trans. On Power Systems*. 2004; 19(2): 1387-1401.
- [3] ZT Faur. Effects of FACTS Devices on Static Voltage Collapse Phenomena. MS dissertation, Dept. Elect. Eng. Univ. of Waterloo; 1996.
- [4] JG Singh, SN Singh, SC Srivastava. An Approach for optimal Placement of Static Var Compensators Based on Reactive Power Spot Price. *IEEE Trans. On Power Systems*. 2007; 22(4).
- [5] CIGRE. Working Group38-01, Task Force No.2 on SVC Compensators. IA Bprimez, Ed., 1986.
- [6] LM Tolbert, TJ King. Power electronics strategy for transmission and distribution and for distributed energy, ORNL/TM- 2005/230. Oak Ridge National Laboratory; 2005.
- [7] A Scarfone, B Oberlin, J Di Luca Jr, D Hanson, C Horwill, M Allen. *Dynamic performance studies for a ±150 Mvar STATCOM for Northeast utilities, Panel session on FACTS applications to improve power system dynamic performance*. Proceedings of the IEEE PES T&D Conference and Exposition, Dallas, Texas; 2003.
- [8] NG Hingorani and L Gyugyi. Understanding FACTS: Concepts and Technology of Flexible AC Transmission Systems. NewYork: *IEEE Press*; 2000.
- [9] NG Hingorani. FACTS-Flexible AC Transmission System. *Proceedings of 5th International Conference on AC and DC Power Transmission*, IEE Conference Publication 345. 1991; 1-7.
- [10] IEEE Power Engineering Society, FACTS Overview. *IEEE Special Publication 95TP108*, 1995.
- [11] IEEE Power Engineering Society, FACTS Applications. *IEEE Special Publication 96TP116-0*, 1996.
- [12] IA Erinmez and AM Foss, (eds.), Static Synchronous Compensator (STATCOM). *Working Group 14.19 CIGRE Study Committee 14*, Document No. 144, August 1999.
- [13] Yong Hua Song and Allan T. Johns, Flexible AC Transmission Systems (FACTS). London, UK: *IEE Press*, 1999.
- [14] Amit Garg and Sanjai Kumar Agarwal, Voltage control and dynamic performance of power transmission system using STATCOM and it's comparison with SVC, *International Journal of Advances in Engineering & Technology*, Jan 2012. IJAET, ISSN: 2231-1963.
- [15] YANG Bai-jie, CHAO Qin, YUAN Tie-jiang, YI Hai-dong. Research of STATCOM Impact on Wind Farm LVRT and Protection. *TELKOMNIKA Indonesian Journal of Electrical Engineering*, 2012; 10(8).
- [16] D Harikrishna, NV Srikanth. Dynamic Stability Enhancement of Power Systems Using Neural-Network Controlled Static-Compensator. *TELKOMNIKA Indonesia Journal of Electrical Engineering*. 2012; 10(3): 9-16.

-
- [17] Ali Mohammadi, Sajjad Farajianpour, Saeed Tavakoli, S Masoud Barakati. Fluctuations Mitigation of Variable Speed Wind Turbine through Optimized Centralized Controller. *TELKOMNIKA Indonesia Journal of Electrical Engineering*. 2012; 10(5): 18-21.