

Dual axis solar tracker system using optimal hybrid controller

Mohammed Rashid Subhi, Jawad Hamad Hameed, Hameed Ali Mohammed

Department of Petroleum Systems Control Engineering, College of Petroleum Process Engineering,
Tikrit University, Salah Adin, Tikrit, Iraq

Article Info

Article history:

Received Jan 23, 2022

Revised Apr 10, 2022

Accepted May 2, 2022

Keywords:

Photovoltaic

Solar tracker system

Stepper motor

Two axes sun tracking

ABSTRACT

Renewable energy plays a crucial role in the modern life. It has several forms, such as wind, hydroelectric, and solar energy. The latter is the most popular energy sources in wide areas. In order to maximize the generated energy from solar panels, these panels should be placed and remain in a vertical position with the sun rays. Therefore, a novel system is proposed in this paper to track the sun rays through designing and implementing a solar tracking system with hybrid controller type (controllino), which a hybrid controller that combines the programmable logic controller (PLC) and microcontroller. This leads us to mix the advantages of PLC and microcontroller thus, get fast and flexible control with several input and output which makes the cost is very low and the software is free and unprotected from the production companies. The system that has been built is controlled by self-controller which has the ability to track the position of the sun and control on the movement of the solar panel in order to keep the direction of the solar panels perpendicular to the sun. As a result, the efficiency will increase without the need to identify the geographical location where the solar panels are located and reduce the cost of generating energy by requiring a minimum number of solar panels.

This is an open access article under the [CC BY-SA](https://creativecommons.org/licenses/by-sa/4.0/) license.

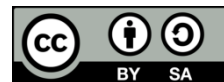

Corresponding Author:

Mohammed Rashid Subhi

Petroleum Systems Control Engineering Control Engineering, Tikrit University

34001, Tikrit, Iraq

Email: Abo1986hhh@tu.edu.iq

1. INTRODUCTION

The continuous and rapid development of the industrial and agricultural sectors have increased the demand for renewable energy sources, including the energy generated from solar panels. Solar energy is an inexhaustible energy regardless of the increased demand for electricity and is clean energy that does not cause any environmental damage. It reduces the use of traditional energy which is threatened with depletion as well as having negative impacts on the global ecosystem [1], [2].

Many countries have produced great efforts to increase the efficiency of solar cells because they are considered as the largest source of clean energy. One method to increase the efficiency of the solar cell is to keep the cell surface perpendicular to the sun as long as possible [3]. This method is followed in this research, where the optical resistors type light-dependent resistors (LDR) is used as a sensor system to determine the location of the sun for solar panels. All research on solar energy have focused on the search for the possibility of investing as much sunlight as possible to increase the efficiency of solar cells [4], [5]. The efficiency of the tracking system that has been implemented can be calculated by (1).

$$\text{Efficiency} = \frac{\text{total power of solar tracking system} - \text{total power of solar fixed system}}{\text{total power of solar fixed system}} * 100 \quad (1)$$

If we can make solar panels vertical with the sun continuously as they move across the sky from east to west, we will be able to get maximum power as possible. What we need is a solar tracking system that keeps the panels facing the sun throughout the day and automatically [6], [7].

Mohd Said *et al.* [8] the development of dual axis solar tracker with the internet of things (IoT) monitoring system, and using Arduino Uno as a primary controller was discussed. To detect sunlight and increase light intensity, four LDR were used, also two servo motors were utilized to move the solar panel toward the detected sun's light source by the LDR. The proposed system was tested and compared to one axial solar tracker. The result showed that the dual axis solar tracking system produced more power, current, and voltage.

Ibbini and Adawi [9] a dual maximum power point tracker (dual-MPPT) was presented and simulated using MATLAB SIMSCAPE to get the global maximum power point (GMPP) under partial shading conditions for a solar photovoltaic module. Dual maximum power point (MPP) trackers are more efficient than conventional single MPP trackers and have more sensitivity to partial shade. Several features can be gotten by using dual MPP trackers, such as the ability of connecting two groups with different row sizes or several solar tilts within high productivity. This paper focus on using dual MPP trackers to make the photovoltaic system work at highest achievable power under partial shading condition to attain the convergence to the global maximum power point GMPP. Most other papers work on dual axis, such as [10], [11]. Therefore, this research focuses on increasing the power of electricity production from solar panels by designing a solar tracking system using the hybrid control type Controllino.

Yousef [12] developed a fuzzy logic algorithm to control sun tracking system based on computer control. To drive the control motors signals for each direction (north-south and south-east) a list of fourteen linguistic rules are taken place. Such as IF $e(k)$ is The $u(k)$ and is B. Many lab experiments are tested for given direction of sun tracker, all tested shows the ability of the system to truck the lights.

Watane and Dafde [13] by taking the sun as a main source or the guide to implement the developed hardware for tracking system, an automatic solar tracking system (ASTS) system is implemented to track the light depends on the sun movement instead of earth movement. In a result, the higher efficiency work is around 25% to 30% of energy is generated and the consumption is very low.

Nguyen and Ho [14], The researchers used a light-dependent resistor (LDR) in order to obtain the highest possible level of electrical power generation through the model that tracks the coordinates of the sun in order to obtain the highest level of light intensity, so that the motors, by receiving signals from the central processing unit, change the direction of the solar panels to a certain direction so that it senses the highest degrees of light brightness. Rashwan and Jailany [15] the researchers deal with controlling the solar panel at two axes by using four lights dependent resistor (LDRs) as sensors, stepper and direct current (DC) motors as actuators (M1, M2) and microcontroller PIC16F877A as a controller unit.

Mehdi *et al.* [16] the study associated by means of the designing and manufacturing process of single axis tracker device by using photo voltaic conversion panels. This solar tracker system assures the conversion optimization of electricity from the source of sun energy by proper using of orientated photovoltaic panel in a manner conforming to the actual direction of sun. Experimental system based on the function of DC motor, which is controlled by dedicated drive astutely so as to move the PV panel in accordance with the signals be given as of effective light sensors.

Mallick *et al.* [18] a mobile prototype of single-axis solar tracking system with the light follower robot based on PIC microcontroller has been proposed. Here we build a light tracking or following robot that moves to the direction of the highest intensity of sun light. In addition, an individual automatic solar tracking system is also mounted. To improve the power efficiency, a simple white reflector is used in this system.

Allamehzadeh [18] focuses on the design of a sun tracker system using four LDRs sensors and electronic control circuits. Two LDR sensors adjust the array inclination angle during the day (East-West) while the other two LDR sensors adjust the tilt angle of the solar array seasonally (North- South). The solar array assembly uses two actuators (dual-axis) to track the sun daily and seasonally. MPPT algorithm is employed to guarantee the maximum power transferred from the solar array to a load.

In this paper, to track the sun rays by designing and implementing a solar tracking system with hybrid controller type (controllino), which a hybrid controller that combines the programmable logic controller (PLC) and microcontroller. The system includes solar panels, stepper motors, hybrid controllers were used in addition to the computer software needed to write and upload the software program. Figure 1 shows the real picture of the solar tracking system that was built:



Figure 1. Solar tracking system that has been built

2. SOLAR TRACKER

The solar tracker is basically a solar panel device that can track the movement of the sun across the sky and ensure that maximum sunlight is projected onto the panels throughout the day [19]. After finding the sun, the tracking system will work to find the optimal location of the panels that gives the largest amount of solar energy [20]. The design of the solar tracking system needs many basic components that can be divided into five main sectors as presented in next section.

2.1. Methods of tracker

In this subsection, two tracking methods are covered in detail. The classification of these methods is conducted according to the number of axes through which the location of the sun is tracked. The methods are single and double axis solar trackers.

2.1.1. Single-axis solar trackers

The single-axis solar trackers can have a horizontal or vertical tracking axis. Horizontal control systems are used in tropical regions where the afternoon time is very long, while the rest of the time is short. Vertical control systems are used in high latitudes where the sun is not very high, but summer days can be very long. The single-axis tracking system is the simplest and most common solution for easy control system construction [21]. Figure 2 shows a single-axis solar tracking system using a horizontal axis.

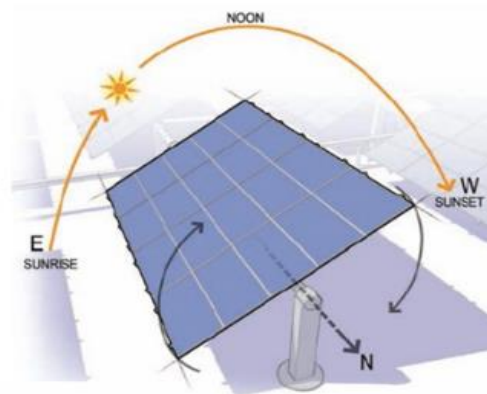

Figure 2. Single-axis solar trackers using the horizontal axis

2.1.2. Double axis solar tracker

The two-track tracking system is a double-tracking system for both horizontal and vertical axes so that the exact movement of the sun can be tracked anywhere in the world accurately. Figure 2 shows a solar tracking system using a horizontal and vertical axis. This type of tracking system is used to control the movement of astronomical telescopes. Using this type of tracking system, solar panel efficiency can be increased by 30-40% [22]-[25] in this research, a two-axis tracking system, based on photo resistors (LDR), was used to determine the location of the sun for the panels.

2.2. Sensor system

The sensor system is an important part of the solar tracking system by which the location of the sun is determined. The sensor system consists of four photo resistors (LDR) distributed over the four directions (east, west, north, south), each of which determines the intensity of the light source. The four sensors are divided into two groups (East/West) and (North/South). In the East/West group, the intensity of the light is measured by both East and West sensors and compared with the algorithm built and upload into the hybrid control.

If the signals are different, the algorithm will calculate which sensors give higher light density than the other, the system will push the panels a step towards the sensor with the highest light density. If the intensity of light for both sensors is equal, that meaning the solar tracking system has achieved the stability of the panels with the sun and thus will maintain the angles of the stepper motor of the set (East/West) fixed and the same applies to the other group.

The photo resistance LDR is a light-sensitive resistance made of highly conductive semi-conductive materials whose resistance changes from about 1,000,000 ohms to zero ohm when light falls. Engineers have benefited from this in many control systems that depend on the amount of light falling. These systems include solar tracking systems. Figure 3 shows how photo resistors are used to determine the position of the sun. This is done by reading signals coming from photo resistors, each representing a particular direction. The four signals are compared and the exact position of the sun is determined.



Figure 3. Optical resistors and positioning system

2.3. Motors and driver circuit

In this research, two stepper motors were used to control the motion of the panels. Since the hybrid controller is used, we do not need drivers circuits to drive the stepper motors rotations because the new controller gives sufficient power to the stepper motors. In Figure 4, the first motor controls the motion of the solar panels horizontally while the second motor controls the vertical direction of the movement of the solar panels. The Gearbox system is also used to increase the torque and stabilize the solar panels so that they are not affected by external factors such as wind and others.

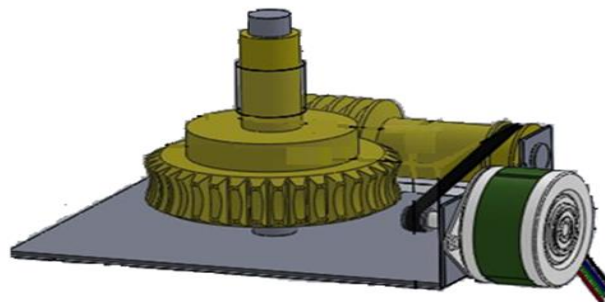

Figure 4. Effects show the first stepper motor with the gearbox system

Figure 5 shows the block diagram of the solar tracking system in its full form of light intensity sensors and hybrid Controllino in addition to linear motors and solar panels. The hybrid controller takes the signal from the photo sensor, where it analyzes the signal and gives the appropriate output that ensures the rotation of the two stepper motor at an angle that ensures that the solar panels remain perpendicular to the sun.

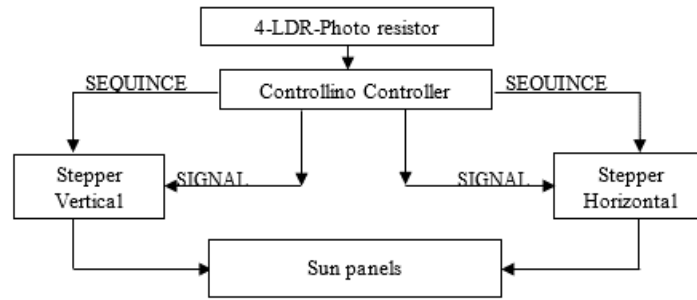

Figure 5. Shows the block diagram of the solar tracking system

2.4. Hybrid controller (Controllino)

Controllino is a hybrid controller that combines the advantages of a programmable logic controller (PLC) and microcontroller. Where the dominant control proposed in this research is reliable and stable at work and robust via the external disturbances that can occur during the operating time. The purpose control has the ability to withstand high electrical currents and the controlling has the flexibility of microcontrollers in terms of speed, programming possibilities and the ability to handle a large number of inputs and outputs. In addition to the fact that the software of this controller is open source, which makes the cost is very low and the software is free and unprotected from the production companies.

The controller (Controllino) that has been used in this study is a modern control and works accurately and with high stability and gives accurate comparison results even if the atmosphere is cloudy as shown in Figure 6. The digital and analogue input/output units, which are similar to the input and output units of the microcontrollers.

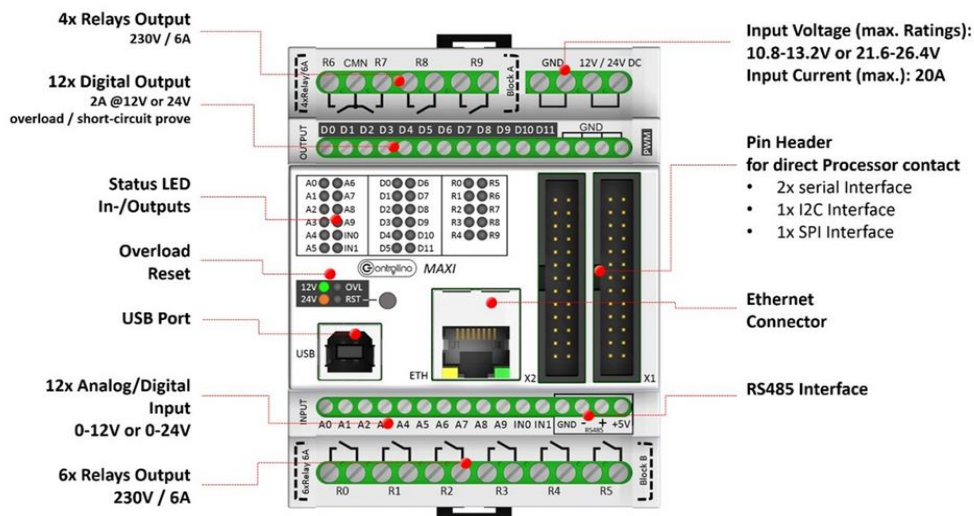

Figure 6. The hybrid controller type (Controllino)

2.5. Tracker algorithm

After reading the signal of each light resistance, the signals are entered into the control, where the algorithm is applied through which the analysis of the signals coming and give the right decision to rotate the stepper motors at the angles required to ensure that the surface of the solar panels be vertical with the sun and continuously throughout the day. The flowchart shown in Figure 7 shows the mechanism of the tracking algorithm and sensor signal reading processes and how to give the appropriate output signals to guide the solar panels in the right direction as well as to read voltages and currents generated from the panels during the daytime. Note that at first the system is activated and then read signals generated by the sensor system (x1, x2, x3, x4), which represent the reading of each sensor (East, West, North, South) respectively. The algorithm then compares the input signals to the control and analyzes them to determine the location of the sun. If there is a difference in the readings of the photoreceptors, the hybrid control will move the step motor

towards the sensor that gave the largest amount of light intensity. When signals coming from photo sensors are equal, this means that the panels stand perpendicular to the sun.

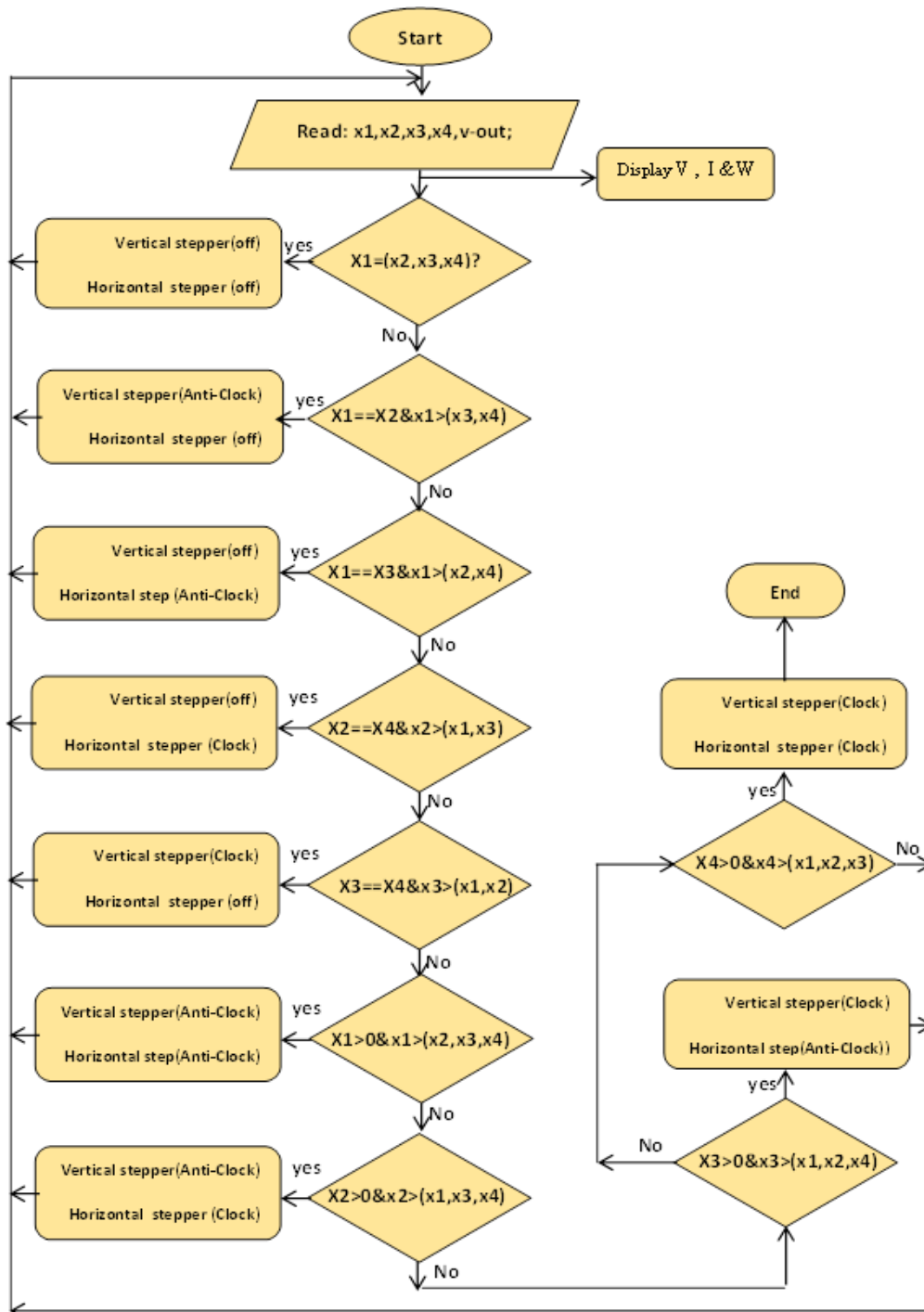

Figure 7. Flowchart of the solar tracking system operation

3. RESULTS

Several metrics were collected in this paper in order to test the proposed method. The output of voltages, currents, and obtained power from fixed solar panels at (45°, 30°) angle and solar panels associated with the solar tracking system is shown in Table 1. These results were measured from 6:00 am to 7:00 pm and were recorded every hour.

Table 1. Voltages, currents and power obtained from fixed and tracking solar panels

Solar Tracking System			Fixed panels at (45°) angle			Fixed panels at (30°)angle			Hours
Power (mW)	Current (mA)	Volt (V)	Power (mW)	Current (mA)	Volt (V)	Power (mW)	Current (mA)	Volt (V)	
1346.876	197.2	6.83	1664.7	235.8	7.06	2038.5	260.1	7.83	am 6:00
1333.48	196.1	6.8	1613.5	232.1	6.95	1497.0	223.2	6.71	am 7:00
1621.12	217.6	7.45	1558.0	228.2	6.78	1282.2	206.3	6.21	am 8:00
1838.284	232.4	7.91	1544.9	227.1	6.73	1269.8	205.3	6.18	am 9:00
1845.311	232.7	7.93	1535.3	226.4	6.78	1253.5	204.1	6.14	am 10:00
1857.915	233.7	7.95	1535.2	226.4	6.8	1237.2	202.8	6.10	am 11:00
1821.068	231.1	7.88	1512.7	224.7	6.83	1217.0	201.3	6.05	am 12:00
1839.76	232	7.93	1499.3	223.7	6.7	1197	199.5	6.00	pm 1:00
1837.493	232.3	7.91	1424.3	218.1	6.53	1169.2	197.1	5.93	pm 2:00
1828.902	231.8	7.89	1385.2	215.0	6.44	987.6	181.2	5.45	pm 3:00
1860.138	233.1	7.98	1338.6	211.4	6.33	370.9	111.0	3.34	pm 4:00
1870.4	233.8	8	1051.1	187.3	5.61	0.0532	1.33	0.04	pm 5:00
1801.8	231	7.8	18.2	24.7	0.74	0.0133	0.665	0.02	pm 6:00
893.048	161.2	5.54	0	0	0	0	0	0.00	pm 7:00
23.6 mW			19.21 mW			14.7 mW			Total Power

From the results shown in Table 1, the total power (Ptotal in mW) which gets, through measuring time period (6:00 am to 7:00 pm), is (23.6 mW) with solar tracking control system and it is (19.21 mW and 14.7 mW) with Fixed panels at (45° and 30°) angle respectively. That means the total power (Ptotal in mW) which gets with solar tracking control system is more than with fixed panels. Also the efficiency of the designed system with solar tracking control system is better than the fixed panels at (45° and 30°) angle respectively as (2) and (3).

$$\text{Power efficiency} = \frac{23.6-19.21}{19.21} * 100 = 22.8\%. \text{ (tracking system compared with fixed angle of (45°))} \quad (2)$$

$$\text{Power efficiency} = \frac{23.6-14.7}{14.7} * 100 = 60.5\%. \text{ (tracking system compared with fixed angle of (30°))} \quad (3)$$

Figure 8 show that the red response represents the response of the obtained power when the solar tracking system is used. The green response represents the obtained power of the fixed solar panels at (45°) while the blue response represents the obtained power of the fixed solar panels at (30°) degree. According to the mentioned figure, the power obtained from the solar tracker system is constant with time and more stable comparison with the constant angle systems while the obtained power dropped after the sun passing the fixed panels angle whether (30° or 45°). For example, the fixed panels at angle (45°) mean the solar system face to East, after the sunlight overtakes noon to the sunset location, the obtained power dropped dramatically, and is also can be exactly in case of (30°) angle.

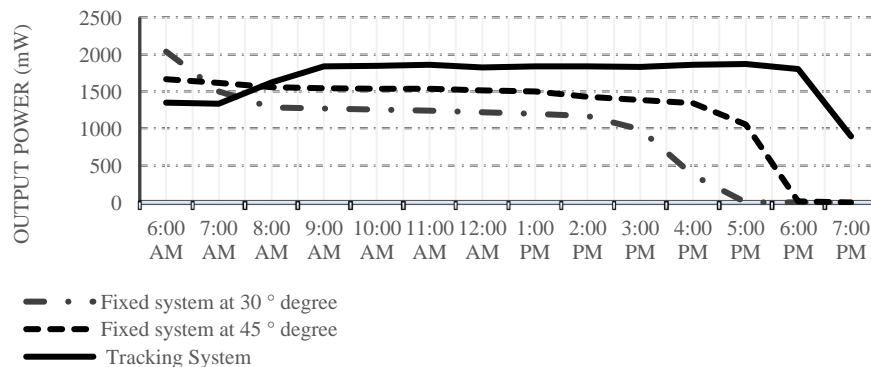

Figure 8. Output power response obtained from the fixed and solar tracking system

4. CONCLUSION



The sun tracking system based on hybrid controller (PLC-microcontroller) has been proposed and designed. The proposed system can track the sun through a set of LDR sensors and then orient the panels with a hybrid controller and stepper motors. This system can work properly irrespective of weather

conditions and location. Specifically, it gives a working software solution for maximizing solar cell output by positioning solar panels at the point of maximum light intensity. This study presents the way to search for the sun, track it, and self-adjust the system at the beginning of the next day. Results show that the proposed tracking system that was built and based on the hybrid control has low cost, fast and flexible control with more total power and high power efficiency compared to a fixed system.



REFERENCES

- [1] N. Maurya, P. Shete, P. Meshram, and S. Khan, "Efficiency enhancement by live sun tracking for solar PV system," *International Journal on Recent and Innovation Trends in Computing and Communication*, vol. 2, no. 12, pp. 4135–4139, 2014, doi: 10.17762/ijritcc.v2i12.3625.
- [2] Z. I. Rizman *et al.*, "Design a simple solar tracker for hybrid power supply," *Journal of Fundamental and Applied Sciences*, vol. 10, no. 2S, p. 334, 2018, doi: 10.4314/jfas.v10i2s.26.
- [3] M. Yilmaz and F. Kentli, "Increasing of electrical energy with solar tracking system at the region which has Turkey's most solar energy potential," *Journal of Clean Energy Technologies*, vol. 3, no. 4, pp. 287–290, 2015, doi: 10.7763/jocet.2015.v3.210.
- [4] S. Arsalan, "Sun tracking system with microcontroller 8051," *International Journal of Scientific & Engineering Research*, vol. 4, no. 6, pp. 2998–3001, 2013, [Online]. Available: <http://www.ijser.org>
- [5] R. Arulmozhiyal and K. Baskaran, "Implementation of a fuzzy PI controller for speed control of induction motors using FPGA," *Journal of Power Electronics*, vol. 10, no. 1, pp. 65–71, 2010, doi: 10.6113/jpe.2010.10.1.065.
- [6] R. Fauzan, A. S. Amir, and H. Miyauchi, "Microcontroller ATmega8535 based solar tracker design for PV system applications in equator region," *International Journal of Control and Automation*, vol. 7, no. 4, pp. 217–234, 2014, doi: 10.14257/ijca.2014.7.4.19.
- [7] I. J. Gabe, A. Bühler, D. Chesini, and F. Froisi, "Design and implementation of a low-cost dual-axes autonomous solar tracker," *2017 IEEE 8th International Symposium on Power Electronics for Distributed Generation Systems, PEDG 2017*, 2017, doi: 10.1109/PEDG.2017.7972522.
- [8] M. N. A. M. Said, S. A. Jumaat, and C. R. A. Jawa, "Dual axis solar tracker with iot monitoring system using arduino," *International Journal of Power Electronics and Drive Systems*, vol. 11, no. 1, pp. 451–458, 2020, doi: 10.11591/ijpeds.v11.i1.pp451-458.
- [9] M. S. Ibbini and A. H. Adawi, "A SIMSCAPE based design of a dual maximum power point tracker of a stand-alone photovoltaic system," *International Journal of Electrical and Computer Engineering (IJECE)*, vol. 10, no. 3, p. 2912, Jun. 2020, doi: 10.11591/ijece.v10i3.pp2912-2917.
- [10] A. P. Yoganandini and G. S. Anitha, "A modified particle swarm optimization algorithm to enhance MPPT in the PV array," *International Journal of Electrical and Computer Engineering*, vol. 10, no. 5, pp. 5001–5008, 2020, doi: 10.11591/IJECE.V10I5.PP5001-5008.
- [11] E. M. H. Arif, J. Hossen, G. R. Murthy, M. Z. H. Jesmeen, and J. Emerson Raja, "An efficient microcontroller based sun tracker control for solar cell systems," *International Journal of Electrical and Computer Engineering*, vol. 9, no. 4, pp. 2743–2750, 2019, doi: 10.11591/ijece.v9i4.pp2743-2750.
- [12] H. A. Yousef, "Design and implementation of a fuzzy logic computer-controlled sun tracking system," *IEEE International Symposium on Industrial Electronics*, vol. 3, pp. 1030–1034, 1999, doi: 10.1109/isie.1999.796768.
- [13] N. D. Watane and R. A. Dafde, "Automatic solar tracker system," *International Journal of Scientific & Engineering Research*, vol. 4, no. 6, pp. 93–100, 2013.
- [14] B. T. Nguyen and H. X. T. Ho, "Design, implementation and performance analysis of a dual axis solar tracking system," *Advances in Science, Technology and Engineering Systems*, vol. 5, no. 3, pp. 41–45, 2020, doi: 10.25046/aj050306.
- [15] M. A. Rashwan and A. T. Jailany, "Design and construction of solar tracking control system," *Misr Journal of Agricultural Engineering*, vol. 31, no. 4, pp. 1549–1562, 2014, doi: 10.21608/mjae.2014.98410.
- [16] G. Mehdi, N. Ali, S. Hussain, A. A. Zaidi, A. Hussain Shah, and M. M. Azeem, "Design and fabrication of automatic single axis solar tracker for solar panel," *2019 2nd International Conference on Computing, Mathematics and Engineering Technologies, iCoMET 2019*, 2019, doi: 10.1109/ICOMET.2019.8673496.
- [17] T. C. Mallick, M. S. Munna, B. Barua, and K. M. Rahman, "A design and implementation of a single axis solar tracker with diffuse reflector," *2014 9th International Forum on Strategic Technology, IFOST 2014*, pp. 289–293, 2014, doi: 10.1109/IFOST.2014.6991124.
- [18] H. Allamehzadeh, "An update on solar energy and sun tracker technology with a dual axis sun tracker application," *Conference Record of the IEEE Photovoltaic Specialists Conference*, pp. 2037–2044, 2019, doi: 10.1109/PVSC40753.2019.8981360.
- [19] J. N. Juang and R. Radharamanan, "Design of a solar tracking system for renewable energy," *Proceedings of the 2014 Zone 1 Conference of the American Society for Engineering Education "Engineering Education: Industry Involvement and Interdisciplinary Trends", ASEE Zone 1 2014*, 2014, doi: 10.1109/ASEEZone1.2014.6820643.
- [20] A. Anuraj and R. Gandhi, "Solar tracking system using stepper motor," *International Journal of Electronic and Electrical Engineering*, vol. 7, no. 6, pp. 561–566, 2014, [Online]. Available: <http://www.irphouse.com>.
- [21] A. Kassem and M. Hamad, "A microcontroller-based multi-function solar tracking system," *2011 IEEE International Systems Conference, SysCon 2011 - Proceedings*, pp. 13–16, 2011, doi: 10.1109/SYSCON.2011.5929048.
- [22] S. Yilmaz, H. R. Ozcalik, O. Dogmus, F. Dincer, O. Akgol, and M. Karaaslan, "Design of two axes sun tracking controller with analytically solar radiation calculations," *Renewable and Sustainable Energy Reviews*, vol. 43, pp. 997–1005, 2015, doi: 10.1016/j.rser.2014.11.090.
- [23] S. H. Chong, N. N. Chandren, and C. R. Allan Soon, "Output energy maximization of a single axis photovoltaic solar tracking system: Experimental verification," *International Journal of Power Electronics and Drive Systems*, vol. 10, no. 3, pp. 1655–1661, 2019, doi: 10.11591/ijpeds.v10.i3.1655-1661.
- [24] A. Abdulmula, K. Sopian, L. C. Haw, and A. Fazlizan, "Performance evaluation of standalone double axis solar tracking system with maximum light detection MLD for telecommunication towers in Malaysia," *International Journal of Power Electronics and Drive Systems*, vol. 10, no. 1, pp. 444–453, 2019, doi: 10.11591/ijpeds.v10n1.pp444-453.
- [25] A. A. Abdulrazzaq and A. H. Ali, "Efficiency performances of two MPPT algorithms for PV system with different solar panels irradiances," *International Journal of Power Electronics and Drive Systems*, vol. 9, no. 4, pp. 1755–1764, 2018, doi: 10.11591/ijpeds.v9.i4.pp1755-1764.



BIOGRAPHIES OF AUTHORS

Mohammed Rashid Subhi    is assistant lecturer at College of Petroleum Process Engineering, University of Tikrit. He holds a Master in Computer Science from Pune University Department of Computer Science (PUCSD), Pune, India. He can be contacted at email: abo1986hhh@tu.edu.iq.



Jawad Hamad Hmeed    is a lecturer at department of petroleum system control, Tikrit University, Iraq. He has a master degree from the Arabic Academic for science and Technology University, Egypt. He has published several papers during the past years. He can be contacted at email: jawad20072003@tu.edu.iq.



Hameed Ali Mohammed    is a lecturer and head of department of petroleum system control, Tikrit University, Iraq. He has a master in control engineering from university of Mosul, Iraq. He has published several papers during the past years. He can be contacted at email: hameed.ali@tu.edu.iq.