A Wireless Greenhouse Monitoring System based on Solar Energy

Liai Gao*, Man Cheng, Juan Tang

College of Mechanical and Electrical Engineering, Agricultural University of Hebei, Baoding 071000, Hebei, China

*Corresponding author, e-mail: 291049221@qq.com

Abstract

To resolve the problems of complicated cabling and costly wired network in the current system, we designed a wireless greenhouse monitoring system based on ZigBee and GSM technology. The system consists of two parts: a wireless sensor network and remote control terminal. According to parameter distribution in the monitoring regional, a wireless transmission network was formed, all of the nodes in the network using solar power. In the remote control terminal, the study developed a simplified expert decision system, in which the part of greenhouse control decision adopts the fuzzy decoupling control algorithm to realize the temperature and humidity decoupling control and increase the accuracy of decision-making. According to the experimental test, the monitoring system can run well under the conditions in northern China greenhouses. It can realize real-time, accurate monitoring and collecting of parameters data in the greenhouse environment; the remote control terminal can give effective decision management solutions. Our future work will mainly be solar photovoltaic panel servo system and image transmission.

Keywords: wireless greenhouse monitoring system, ZigBee network, expert decision system, solar energy

Copyright © 2013 Universitas Ahmad Dahlan. All rights reserved.

1. Introduction

China is a major agricultural country in the world, with agriculture as its traditional and basic industry. With continuous improvement and progress of the basic conditions and technology degree, input level is gaining constant increase. However, agricultural development still faces many problems and challenges. So implementation of ecological agriculture in line with national conditions is a necessary way to promote China's agricultural development.

With the development of facilities agriculture and expansion greenhouse planting areas, it is very important to shed the greenhouse environment parameters in real-time accurate measurement and control. Traditional environmental monitoring system is usually achieved by wired network, making the system complex and costly [1]; literature [2, 3] proposed the ideology of wireless sensor networks for data acquisition. However, how to solve the problem of system power supply effectively is rarely reported. If battery power is used, the battery must be replaced periodically and a large number of used batteries will cause environmental pollution. Therefore, the problem of power supply must be solved to achieve a true sense of "wireless" transmission.

In view of the above questions, we develop a wireless greenhouse monitoring system based on solar energy, combining with the greenhouse environmental characteristics and monitoring requirements. Wireless sensor networks (WSN) are thought preponderant to meet the greenhouse requirements and replace the wired connections in traditional system. With solar cell, solar energy was collected and stored in lithium battery to provide power supply for the system. In addition, the study developed a simplified expert decision system in the remote control terminal, in which the control decision adopts fuzzy decoupling control algorithm to realize the temperature and humidity decoupling control and increase the accuracy of decision-making in turn.

2. System Description

The system consists of two parts: a wireless sensor network and remote control terminal. Using the design concept of terminal monitoring nodes and sink nodes in wireless

sensor network, these nodes are formed a tree network. The main function of the network is data collection. After fusion processing, the data are sent to remote control terminal through GSM network in the form of short message. And at the same time, the expert decision system of remote control terminal gives the corresponding decision according to the received data. The overall system structure is shown in Figure 1.

3. A Wireless Sensor Network

Wireless sensor network is composed of a large number of cheap micro-sensor nodes which are deployed in the monitoring area. The function of terminal node is monitoring environmental data collection; sink node is the core of the entire system operation, which is responsible for establishing the entire wireless sensor network, receiving, processing and forwarding the data of terminal node collection [4, 5].

3.1. Hardware

3.1.1. Terminal Node

Node mainly consists of a processor module and wireless communication module. This design uses the CC2430 chip, thereby simplifies the circuit design [6]. In addition to the completion of the data transceiver, the terminal node also drives the connected sensors for data collection, so the node requires sensor module. And all of the nodes are powered by solar energy, node structure is shown in Figure 2.

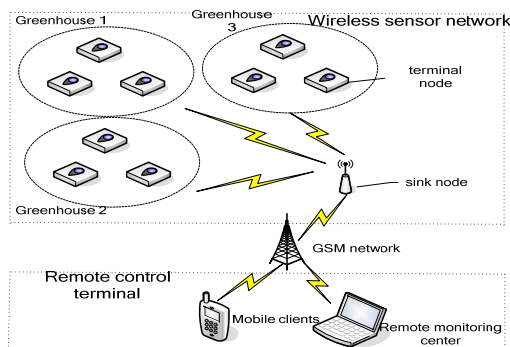

Figure 1. The Structure Diagram of Overall System

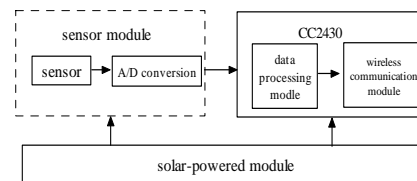

Figure 2. The Structure Diagram of Terminal Node

A. Introduction of CC2430

The CC2430 is a true System-on-Chip (SoC) solution specifically tailored for IEEE 802.15.4 and ZigBee™ applications. It enables ZigBee™ nodes to be built with very low total bill-of-material costs. The CC2430 combines the excellent performance of the leading CC2420 RF transceiver with an industry-standard enhanced 8051 MCU, 32/64/128 KB flash memory, 8 KB RAM and many other powerful features. It is used widely in the wireless temperature monitoring system.

B. Sensors

Fast response time, low power consumption and tolerance against moisture climate made SHT11 relative humidity and temperature sensor a perfect solution for the greenhouse environment. Luminosity was measured by ISL29010, which converts light intensity to voltage. Unstable output signal is handled by low-pass filter to get correct luminosity values.

These two kinds of sensors are in line with the I^2C agreement, but CC2430 haven't I^2C bus interface, so bus clock line and digital line of ISL29010 and SHT11 could be simulated by P0.2 and P0.3.

C. Solar power supply module

In order to solve the node energy supply problem, we proposed a supply system based on solar energy, which is composed by solar modules, solar controller, and lithium battery [7].

The solar module is the core of solar energy power supply system, which puts the sun's radiation energy into electricity, sends to battery to be stored up, or pushes load work; solar controller is used to control the whole module working condition; Lithium battery is an emergency system energy source. The structure power supply module is shown in Figure 3.

(1) Solar cell matrix

Preliminary we choose a piece of solar panels for 6V, 3Wp.

(2) Battery capacity

The capacity of the battery is very important for ensuring continuous power supply. Daily generating capacity of the solar array should be stored in a storage battery for consumption. Therefore, the capacity calculation formula of the battery is:

$$\begin{aligned}
 B_c &= A \times Q_L \times N_L \times T_0 \div C_c \\
 &= 1.4 \times 1.2 \times 7 \times 1 \div 0.8 \\
 &= 14.7Ah \approx 15Ah
 \end{aligned}
 \tag{1}$$

So, we choose a battery model for 4.5V/15AH.

3.1.2. Sink Node

Sink node is the data aggregator of the entire system. In addition to CC2430, the node is also equipped with a GSM module (*TC35i*). It supports the communication standards of GSM7.07 and GSM7.05; provides users with the standard AT command interface [8]. CC2430 have two UART serial ports, which can connect with *TC35i* by a UART. Operating voltage of CC2430 is 2.0-3.6 V, typical value is 3.0 V, and the typical value of serial electric flat for *TC35i* is 2.65V. We can string a resistance to protect the serial TXD0 end of *TC35i* when connecting. The connection of CC2430 and *TC35i* is shown in Figure 4.

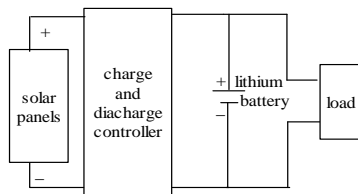

Figure 3. Structure Diagram of Solar-powered Module

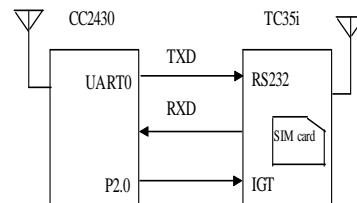

Figure 4. The Connection of CC2430 and TC35i

3.2. Software

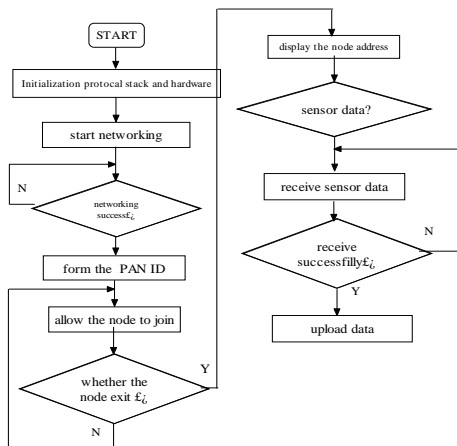

Figure 5. The Software Flowchart of Sink Node

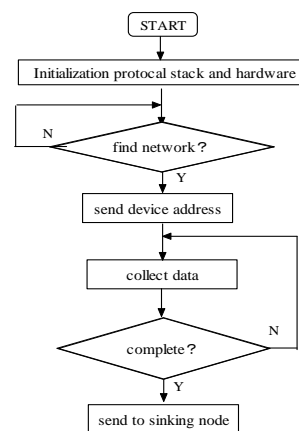

Figure 6. The Software Flowchart of Terminal Node

In determining the overall function of the network, we focus on program writing of sink nodes and terminal node. The process of sink node is as follows: First of all, select a channel and Network PAN ID (Personal Area Network Identity), so as to establish the Network, and timing interception whether internet connection have request; Secondly, if sink nodes receive terminal nodes' access request, then judge whether to join the network according to the request, if allowed to join, the sink node tells the terminal node a network address as the only identity identification; Finally, the sink node sends to each node related control command at regular time[9]. The software flowchart of sink node is shown in Figure 5.

The main task of terminal node is data acquisition and transferring, after completing initialization protocol stack and hardware, the terminal node start scanning channel, and then sends the information of joining the network. If confirmed, it began to collect data through the sensors, and then sends to the sink node through the wireless transmission. The software flowchart of terminal node is shown in Figure 6.

4. Expert Decision System

The greenhouse environmental system is a multi-variable, nonlinear, time-varying and delayed system there are coupling relationship among variables, it is difficult to establish a precise mathematical model [10]. Among them, temperature and humidity is a basic factor. The relationship between the temperature and humidity in the greenhouse environment is not fragmented, but a complex coupling relationship. An amount of change will affect another. This study introduces a fuzzy control method in the control section, establishes fuzzy control model of the greenhouse environment, confirms a decoupling parameters between the temperature and humidity, and achieves decoupling control temperature and humidity, so that the control accuracy of the entire system get the corresponding improvement.

4.1. Regulated Mechanism

In this study, the research object of greenhouse is operating the shade and ventilating the window, we established 4 input and 2 output fuzzy controllers [11]. Two control objects in combination with each other. These four kinds of control methods are shown in Table 1, where 1 indicates the action is open, 0 indicates the operation is off; \uparrow indicates an increase, \downarrow indicates a decrease. The two operations can achieve the purpose of controlling the temperature and humidity. But the mutual coupling relationship exists in them, and there is also the occurrence of conflict situations, it may not make the temperature and humidity reach a suitable operating level at the same time.

4.2 Construction of Fuzzy Decoupling Controller

4.2.1. Structure

A conventional fuzzy control means that it compares the setting value of the control amount with the measured value of the time of t to obtain deviation e , and then come to the rate of change deviation e^C . Through the digital fuzzy, then get fuzzy quantity E and EC . It uses Fuzzy control rules R , gets fuzzy control amount U , Finally makes the fuzzy control amount defuzzification, then become precise amount u . Finally we could achieve fuzzy control of the controlled object. This method is more suitable for the control of greenhouse environment.

From Table 1, we can see that opening shade may cause temperature rising, while humidity dropping; opening the shade may cause the changes of temperature and humidity in the same direction. In order to achieve effective decoupling of temperature and humidity, we select shade operating as main loop of temperature control, windows operating as humidity control circuit. At the same time we take the control strategy which is given priority to temperature, and an ounce of prevention for humidity. Decoupling control system diagram is shown in Figure 7, T_0 and H_0 is pre-set by expert decision-making system which is suitable for temperature and humidity of crop growth stage, e_T is temperature deviation, e_H is humidity deviation, e^C_T and e^C_H is the rate of change of each deviation over time.

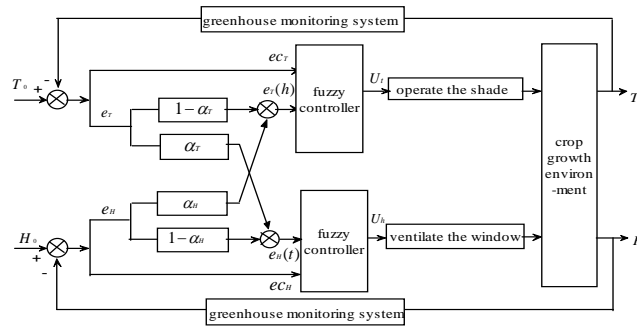

Figure 7. Fuzzy Decoupling Control Diagram

The interaction between temperature and humidity make a big effect in actual greenhouse. In order to weaken the coupling relationship, this system introduces the decoupling parameter α_T and α_H , specific usage is as follows:

$$e_T(h) = (1 - \alpha_T)e_T + \alpha_H e_H \tag{2}$$

$$e_H(t) = (1 - \alpha_H)e_H + \alpha_T e_T \tag{3}$$

Through introduction of decoupling parameters and the fuzzy control system operation, we ultimately get perform operations which is the concrete considering temperature and humidity affect each other.

4.2.2. Algorithm

Whether to construct fuzzy controller reasonably is related to the precision of fuzzy control system, the structure of fuzzy logic controller is shown in Figure 8. The reasoning process is divided into the following four steps [12]: Firstly, transform the amount of input and output into fuzzy sets, and define their universe, and then build a fuzzy table by the actual changes scope of the input and output amount, Secondly, establish the knowledge base through the knowledge and experience of experts, and form the fuzzy control rule table; Thirdly, use fuzzy table and fuzzy control rule table, adopt offline indirect reasoning to establish control table, and calculate the amount of the corresponding fuzzy control; Finally, make fuzzy control amount defuzzification for transforming into ultimate control parameters.

Table 1. Related Operation to the Changes of Temperature and Humidity

	Operate the shade	Ventilate the window	Temperature	Humidity
1	0	0	↑	↑
2	0	1	↓	↓
3	1	0	↑	↓
4	1	1	↑	↓

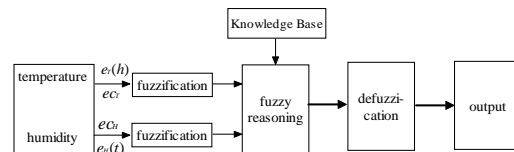

Figure 8. The Structure of Fuzzy Logic Controller

5. System Test

In order to test the validity of data transmission and the rationality decision of expert decision system, we selected an agriculture sightseeing garden located in XuShui, Hebei province as the experimental base. The base has 10 greenhouses with tomato as the main crops. We selected Jan. 5, 2013 as the test date, and that day would be in the tomato blossom period. The test system consists of four terminal nodes and a sink node. The four terminal nodes were deployed to one greenhouse block to gather information in climate variables between lower and upper flora. The air temperature and humidity sensor and light intensity

sensor were located on the lifting lever of terminal node. By changing the lifting lever height, the system can adapt to a variety of crops. The specific installation positions of nodes are: Node 1 was placed 320 cm away from the side wall of the greenhouse and it was hanged in 100 cm 's height. Node 2 was 160 cm away from the side wall and it was placed at the height of 123 cm . Node 3 was located above Node 2. Distance between Node 4 and Node 1 was 195 cm .

5.1. Wireless Transmission Test

Through the actual deployment, when the communication distance of the node is about 30m, the system can be completed in setting up the wireless sensor network and all terminal nodes form self-organizing networks within 30 seconds. After data sampling, the terminal nodes can send data within 30 seconds; after receiving the data, sink node can send the data to the mobile phone within 2 minutes by SMS.

5.2. Temperature and Humidity Decision Effect in 24 Hours of Blossom Period

During the day, farmers entered the greenhouse for 6 times, the time were 7, 9, 11, 13, and 15, 17 o'clock respectively; at night they entered into the greenhouse 4 times, times were 23, 2 and 5 o'clock respectively. Through the decision-making system, 10 times decision scheme were given (Temperature is abbreviated as T, its unit was $^{\circ}C$, while relative humidity is abbreviated as H, its unit was $RH\%$). We can get the line chart of Temperature and humidity within 24 hours through the decision result data, as shown in Figure 9 and Figure 10.

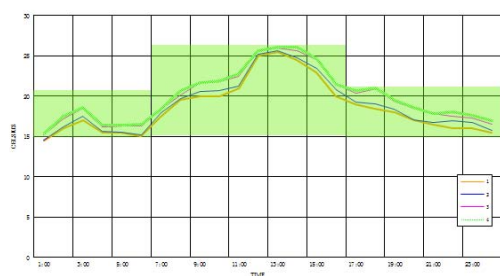

Figure 9. Decision Temperature in 24 hours of Blossom Period

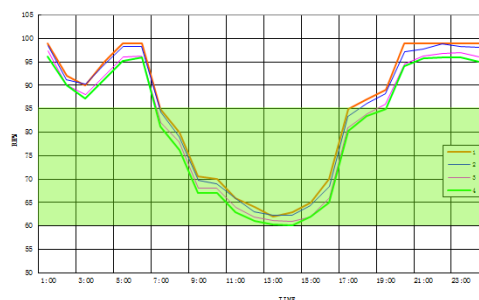

Figure 10. Decision Humidity in 24 Hours of Blossom Period

The following conclusions can be obtained from the diagram:

1) Since nodes 1 and node 2 were located in the lower part of the dense foliage of tomato plants, the relative humidity measured by these two nodes is a little higher than node 3 and node 4.

2) The area marked green in figure 10 is within the optimal growth temperature range in tomato blossom period. We can see that decision-making in temperature is always within the range of optimum growth during the day (7:00 am to 18:00); during the night (pm18:00 to 7:00 the next day), we can see that the decision-making temperature is always in the appropriate temperature range. In Figure 11 where marked green is for the suitable humidity range, we can also see that humidity substantially ensure the appropriate humidity through the decision during the day. Because there is no corresponding dehumidification equipment during the night, the moisture inevitably began to increase as the temperature decreases. Although decision-making system gives decision scheme, but farmers do not have enough executive capability for humidity, so humidity is no longer as the result of decision data in the night.

6. Conclusions and Future work

The system generated by solar cell power and lithium battery energy storage device is the development trend of future energy supply device of low-power wireless sensor; ZigBee wireless network are used in data transmission, which effectively change the traditional wired detection method, avoiding complicated wiring; In the remote control terminal, the system sets up expert decision systems, using fuzzy decoupling algorithm for environmental control and

realizing decoupling control of temperature and humidity. And it greatly improved the decision-making effect of this system. The experimental results show that the system achieves automatic real-time monitoring of environmental parameters and gives correct decision plans, which is of a broad application prospect.

With the application and popularization of the system and the development of technology, this study will also conduct further research in the following areas:

First, because the angles of the sun are changing, our following work will take the design of solar photovoltaic panels' servo system into consideration, making solar panels, like sunflower, directly face the sun at any time, to keep the perpendicular angle of sun's rays and solar panels to improve the utilization of solar energy.

Second, with the popularity of 3G network, the system will take 3G technology into account, to realize the image and video transmission function in the future.

Acknowledgments

This work was supported by the high school scientific and technological research guidance project in Hebei province (No.Z2011271 & No.11227179) and the science and technology research guidance project in Baoding (No.12ZN022)

References

- [1] Jonas M, Marland G, Winiwarter W, White T, Nahorski Z, Bun R, Nilsson S, Milfried. Benefits of dealing with uncertainty in greenhouse gas inventories: Introduction. *Climatic Change*. 2010; 103(1): 3-18.
- [2] Fitch M, Nekovee M, Kawade S, Briggs K, MacKenzie R. Wireless services provision in TV white space with cognitive radio technology: A telecom operators perspective and experience. *IEEE Communications Magazine*. 2011; 49(3): 64-73.
- [3] Dae-Heon Park, Beom-Jin kang, Kyung-Ryong Cho. A Study on Greenhouse Automatic Control System Based on Wireless Sensor Network. *Wireless Personal Communications*. 2011; 56(1): 117-130.
- [4] Watteyne T, Molinaro A, Richichi MG, Dohler M. From MANET To IETF ROLL Standardization:A Paradigm Shift in WSN Routing Protocols. *IEEE Communications Surveys Tutorials*. 2011; 13(4): 688-707.
- [5] Sifuentes E, Casas O, Pallas-Arey R. Wireless Magnetic Sensor Node for Vehicle Detection with Optical Wake-Up. *IEEE Sensors Journal*. 2011; 11(8): 1669-1676.
- [6] Sabri N, Aljunid SA, Ahmad RB, Yahya A, Kamaruddm R, Salim MS. Wireless sensor actor network based on fuzzy inference system for greenhouse climate control Source. *Journal of Applied Sciences*. 2011; 11(17): 3104-3116.
- [7] Panwar NL, Kaushik SC, Kothari S. Solar greenhouse an option for renewable and sustainable farming. *Renewable and Sustainable Energy Reviews*. 2011; 15(8): 3934-3945.
- [8] Okundamiya MS, Nzeako AN. Model for optimal sizing of a wind energy conversion system for green-mobile applications. *International Journal of Green Energy*. 2013; 10(2) : 205-218.
- [9] Yu Ksel E, Nielson HR, Nielson FA. Secure Key Establishment Protocol for ZigBee Wireless Sensor Networks. *Computer Journal*. 2011; 54(4): 589-601.
- [10] Sabri N, Aljunid SA, Ahmad RB, Malek MF, Yahya A, Kamaruddin R, Salim MS. Smart Prolong Fuzzy Wireless Sensor-Actor Network for Agricultural Application. *Journal of Information Science and Engineering*. 2012; 28(2): 295-316.
- [11] Her-Terng Y, Chieh-Li C. Fuzzy sliding mode controller design for maximum power point tracking control of a solar energy system. *Transactions of the Institute of Measurement and Control*. 2012; 34(5): 557-565.
- [12] Ehret David L, Hill Bernard D, Helmer Tom, Edwards Diane R. Neural network modeling of greenhouse tomato yield, growth and water use from automated crop monitoring data. *Computers and Electronics in Agriculture*. 2011; 79(1): 82-89.