

State Feedback Linearization of a Non-linear Permanent Magnet Synchronous Motor Drive

Pilla Ramana^{1*}, Karlapudy Alice Mary², Munagala Surya Kalavathi³

¹Dept. of EEE, GMR Institute of Technology, Rajam, Srikakulam, AP-532127, India

²Vishwakarma Institute of Information Technology, Visakhapatnam, AP-533045, India

³Dept. of EEE, JNTUCE, Jawaharlal Nehru Technological University, Hyderabad, AP-500072, India

e-mail: pramana.gmrit@gmail.com

Abstract

Control system design for inverter fed drives previously used the classical transfer function approach for single-input singleoutput (SISO) systems. Proportional plus Integral (PI) controllers were designed for individual control loops. It is found that the transient response of a PI controller is slow and is improved by pole placement through state feedback. However, the effective gains of the PI controller are substantially decreased as a function of the increase of motor speed. A control system is generally characterized by the hierarchy of the control loops, where the outer loop controls the inner loops. The inner loops are designed to execute progressively faster. The speed controller (PI controller) processes the speed error and generates the reference torque. In the inner loop, firstly a non-linear controller is designed for the system by which the system nonlinearity is canceled using state or exact feedback linearization. In addition, a linear state feedback control law based on pole placement technique including the integral of output error (IOE) is used in order to achieve zero steady state error with respect to reference current specification, while at the same time improving the dynamic response. The proposed scheme has been validated through extensive simulation using MATLAB.

Keywords: Permanent Magnet Synchronous Motor, Non-linear controller, PI controller, State feedback controller, Integral of Output Error

1. Introduction

Although ac drives require advanced control techniques for control of voltage, frequency and current, they have many advantages over dc drives like reduced power line disturbances, lower power demand on start, controlled acceleration, controlled starting current, adjustable operating speed and adjustable torque. The permanent magnet motors are similar to the salient pole motors, except that there is no field winding and the field is provided instead by mounting permanent magnets in the rotor. The equations of the salient pole motors may be applied to the PM motors, if the excitation voltage is maintained constant. Due to this, there is no excitation voltage source, field winding, collecting rings and brushes; resulting in improving efficiency when compared to other machines. By considering various features such as good dynamic performance, easy controllability, high torque to inertia ratio, high efficiency and improved power factor, Permanent Magnet Synchronous Motor (PMSM) drives [1-2] are used in robotics, machine tools, pumps, ventilators, compressors etc.

The mathematical model of a PMSM [1-2] is non-linear and cannot be represented in linear state space form. Thus, the conventional control system design techniques are not applicable to this system directly. Isidori [3] and M. Ilic-Spong et al. [4] developed the concept of dynamic feedback linearization to switched reluctance motor. KS Low et al. [5] applied the feedback linearization [6] technique to transform the nonlinear equations into a linear time invariant state model for a PMSM. The state transformation is essentially the familiar d-q transformation, whilst the non-linear feedback law performs decoupling and compensation for the influence of back emf in the motor. Zribi and Chiasson [7] proposed exact linearization for position control of PM stepper motor. Jun Zhang et al. [8] discuss decoupling control applied to PMSM using exact linearization. AK Parvathy et al. [9] applied quadratic linearization to PMSM, since PMSM can be adequately described by a quadratic model during normal operation. Safieh Izad and Mahmood Ghanbari [10] discussed speed control of permanent magnet synchronous motor using feedback linearization method.

In this paper, exact linearization of the model of a PMSM with damper windings has been attempted. The proposed controller represented in the conventional two-loop structure [11] for the motor drive is shown in Figure 1. The outer loop is the speed controller, the output of which is the reference value of the torque, T_e^* . From this value, the reference values of the currents such as i_{qs}^* and i_{ds}^* are computed for a desired internal angle (ψ) and a desired torque angle (δ). This gives rise to the flexibility in choosing the power factor of the motor from lagging to leading values including unity. The field oriented control [12] can also be obtained as a special case, by setting the power factor angle to be equal to the torque angle, resulting in complete decoupling between the armature flux and the field flux, thus, producing a dc motor like behavior. In this sense, the proposed control scheme is more general than conventional field oriented control. The inner (current) loop is then considered. Here, firstly a non-linear controller is designed for the system by which the system nonlinearity is canceled. In addition to this, a linear state feedback control law [13-14] based on pole placement technique including the integral of output error (IOE) is used in order to achieve zero steady state error with respect to reference current specification, while at the same time improving the dynamic response [2].

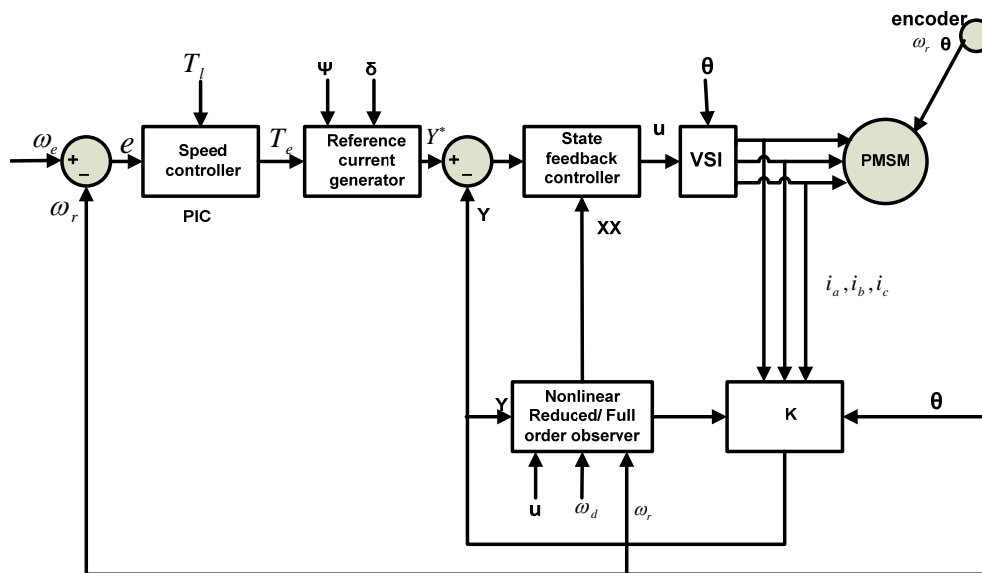

Figure 1. Block-diagram of proposed control system

2. Mathematical Modelling of PMSM

In order to design a control system for high performance drive, the mathematical model [17-18] of the machine is very much essential. To develop mathematical model of PMSM, the actual machine in a-b-c reference frame [19] is converted into d-q axis representation. By using mathematical modelling, the complexity of calculations is reduced while analyzing the system performance of any machine. Also the time variant inductance is treated as time invariant inductance and the sinusoidal quantities are represented as dc quantities. The schematic diagram of PMSM with damper windings is as shown in Figure 2. The model of PMSM with damper winding has been developed on rotor reference frame using d-q axis [19] representation.

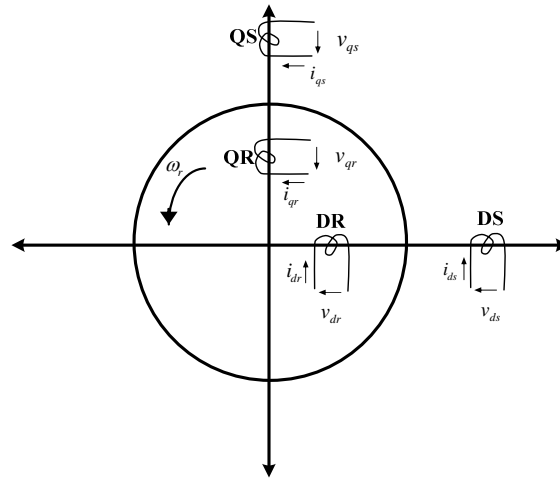

Figure 2. Permanent Magnet Synchronous Machine

The modelling equations of PMSM in rotor reference frame are given as below:

$$v_{qs} = r_a i_{qs} + l_{qs} p i_{qs} + l_{aq} p i_{qr} + \omega_r l_{ds} i_{ds} + \omega_r l_{ad} i_{dr} \quad (1)$$

$$v_{ds} = r_a i_{ds} + l_{ds} p i_{ds} + l_{ad} p i_{dr} - \omega_r l_{qs} i_{qs} - \omega_r l_{aq} i_{qr} \quad (2)$$

$$v_{dr} = r_{dr} i_{dr} + l_{dr} p i_{dr} + l_{ad} p i_{ds} \quad (3)$$

$$v_{qr} = r_{qr} i_{qr} + l_{qr} p i_{qr} + l_{aq} p i_{qs} \quad (4)$$

The electrical torque developed is,

$$T_e = \frac{3}{2} \times \frac{P}{2} [(l_{ad} - l_{aq}) i_{ds} i_{qs} + l_{ad} i_{qs} i_{dr} - l_{aq} i_{qr} i_{ds}] \quad (5)$$

The torque balance equation of the given system is

$$p \omega_r = \frac{P}{2J} [T_e - T_l - \frac{2}{P} J \omega_r] \quad (6)$$

The above equations can be written in matrix form as,

$$\begin{bmatrix} v_{qs} \\ v_{ds} \\ v_{qr} \\ v_{dr} \end{bmatrix} = \begin{bmatrix} r_a + l_{qs} p & \omega_r l_{ds} & l_{aq} p & \omega_r l_{ad} \\ -\omega_r l_{qs} & r_a + l_{ds} p & -\omega_r l_{aq} & l_{ad} p \\ l_{aq} p & 0 & r_{qr} + l_{qr} p & 0 \\ 0 & l_{ad} p & 0 & r_{dr} + l_{dr} p \end{bmatrix} \begin{bmatrix} i_{qs} \\ i_{ds} \\ i_{qr} \\ i_{dr} \end{bmatrix} \quad (7)$$

Now to bring these equations in terms of state space representation and the modified equations as,

$$\begin{bmatrix} l_{qs} & 0 & l_{aq} & 0 \\ 0 & l_{ds} & 0 & l_{ad} \\ l_{aq} & 0 & l_{qr} & 0 \\ 0 & l_{ad} & 0 & l_{dr} \end{bmatrix} \begin{bmatrix} pi_{qs} \\ pi_{ds} \\ pi_{qr} \\ pi_{dr} \end{bmatrix} = \begin{bmatrix} r_a & \omega_r l_{ds} & 0 & \omega_r l_{ad} \\ -\omega_r l_{qs} & r_a & -\omega_r l_{aq} & 0 \\ 0 & 0 & r_{qr} & 0 \\ 0 & 0 & 0 & r_{dr} \end{bmatrix} \begin{bmatrix} i_{qs} \\ i_{ds} \\ i_{qr} \\ i_{dr} \end{bmatrix} + \begin{bmatrix} v_{qs} \\ v_{ds} \\ v_{qr} \\ v_{dr} \end{bmatrix} \quad (8)$$

From the above equation we can define the following matrices for simplification,

$$A_x = \begin{bmatrix} r_a & \omega_r l_{ds} & 0 & \omega_r l_{ad} \\ -\omega_r l_{qs} & r_a & -\omega_r l_{aq} & 0 \\ 0 & 0 & r_{qr} & 0 \\ 0 & 0 & 0 & r_{dr} \end{bmatrix} \quad (9)$$

$$A_y = \begin{bmatrix} l_{qs} & 0 & l_{aq} & 0 \\ 0 & l_{ds} & 0 & l_{ad} \\ l_{aq} & 0 & l_{qr} & 0 \\ 0 & l_{ad} & 0 & l_{dr} \end{bmatrix} \quad (10)$$

$$x = [i_{qs} \quad i_{ds} \quad i_{qr} \quad i_{dr}]^T \quad (11)$$

$$B_x = \begin{bmatrix} 1 & 0 \\ 0 & 1 \\ 0 & 0 \\ 0 & 0 \end{bmatrix} \quad (12)$$

Thus, equation (8) can be written in the form,

$$A_y \dot{x} = A_x x + B_x u \quad (13)$$

or it will be modified as,

$$\dot{x} = Ax + Bu \quad (14)$$

with $A = (A_y^{-1} A_x)$ & $B = (A_y^{-1} B_x)$

3. Design of the Speed Controller (PI Controller)

The basic assumption in separating the speed loop from the overall closed loop system (figure 1) is that the dynamics of the current controller is sufficiently fast, so that no appreciable change in the speed takes place during its transient phase. This has to be ensured by design and implies that the closed loop band-widths of these two loops must differ by at least a factor of ten. A proportional-cum-integral (PI) controller is used for this loop. The output of the PI controller is the reference torque T_e^* , from which the reference currents, i_{qs}^* and i_{ds}^* can be generated. The design of the gain constants of this controller is as follows:

Considering the torque balance equation (6) involving speed (i.e., mechanical part),

$$p \omega_r = \frac{P}{2J} [T_e - T_l - \frac{2}{P} J \omega_r] \quad (15)$$

And the torque balance equation for no. of poles, P=4 is taken as

$$p \omega_r = \frac{2}{J} [T_e - T_l - \frac{\beta \omega_r}{2}] \quad (16)$$

The equation of PI controller is

$$T_e^* = k_p e + k_i \int_0^t e dt \quad (17)$$

Where,

$$e = (\omega_e - \omega_r) \quad (18)$$

Here ω_e is the set speed, ω_r is the reference speed and k_p and k_i are the proportional and integral gains of the PI controller respectively.

Substituting (17) and (18) in (16) and taking Laplace transform, we get

$$(s\omega_r - \omega_{r0}) = \frac{2}{J} \left[\left(k_p + \frac{k_i}{s} \right) (\omega_e - \omega_r) - T_l - \left(\frac{3}{2} \right) \omega_r \right] \quad (19)$$

For $T_l = 0$ and $\omega_{r0} = \omega_e$ rearranging the terms in equation (19),

$$\left[s + \frac{\beta}{J} + \frac{2}{J} \left(k_p + \frac{k_i}{s} \right) \right] \omega_r = \left[\frac{2}{J} \left(k_p + \frac{k_i}{s} \right) + 1 \right] \omega_e \quad (20)$$

From which the ratio, $\left(\frac{\omega_r}{\omega_e} \right)$ is obtained as

$$\frac{\omega_r}{\omega_e} = \frac{\frac{2}{J} \left(k_p + \frac{k_i}{s} \right) + 1}{s + \frac{\beta}{J} + \frac{2}{J} \left(k_p + \frac{k_i}{s} \right)} = \frac{\left(k_p + \frac{k_i}{s} \right) s + \frac{2}{J} k_i}{s^2 + \left(\frac{\beta}{J} + \frac{2}{J} k_p \right) s + \frac{2}{J} k_i} \quad (21)$$

This is the standard form of transfer function for a second order system and the denominator can be represented in the form

$$s^2 + 2\xi\omega_n s + \omega_n^2 = 0 \quad (22)$$

where

ξ = desired value of damping ratio, and

ω_n = desired value of natural frequency

The characteristics of the above system is

$$s^2 + \left(\frac{\beta}{J} + \frac{2}{J} k_p \right) s + \frac{2}{J} k_i = 0 \quad (23)$$

Therefore, equating the corresponding terms in equations (22) and (23)

$$\omega_n^2 = \frac{2k_i}{J} \quad (24)$$

$$2\xi\omega_n = \frac{\beta}{2} + \frac{2k_p}{J} \quad (25)$$

The value of ξ is usually determined from the requirement of permissible maximum overshoot and the un-damped natural frequency, ω_n determines the time response. The controller gains, k_i and k_p are obtained as,

$$k_i = \frac{J}{2}\omega_n^2 \quad (26)$$

$$k_p = J\xi\omega_n - \frac{\beta}{2} \quad (27)$$

Assigning proper values of ξ and ω_n and using the values of J and β , the numerical values of proportional and integral gain constants can be computed.

4. State Feedback Linearization

It is evident from equations (1) - (4) that the system matrices representing the electrical subsystem of PMSM are functions of ω_r , which varies with the operating point and makes the system model coupled and non-linear. Thus, standard techniques of linear system theory cannot be applied directly to design the control system in this situation. To overcome this problem, feedback linearization has been suggested by Isidori [3]. The central idea of the approach is to transform a non-linear model into a linear one by state feedback to which linear control techniques can be applied.

The system model using only the voltage equations (i.e, the electrical subsystem) is expressed as

$$\dot{x} = Ax + Bu \quad (28)$$

Partitioning A into A_1 and A_2

$$\dot{x} = (A_1 + \omega_r A_2)x + Bu \quad (29)$$

Thus, the system matrix A in equation (29) has a term proportional to ω_r . To cancel this, a feedback term is needed, which depends on the product $\omega_r x$. Choose a feedback control law of the form,

$$u = u_1 + u_2 \quad (30)$$

where u_1 and u_2 are the input control vectors of the non-linear and linear parts respectively. The non-linear feedback control law is chosen as

$$u_1 = \omega_r k_1 x \quad (31)$$

where k_1 is the feedback gain matrix.

Substituting (30) and (31) in (29),

$$\begin{aligned} \dot{x} &= (A_1 + \omega_r A_2)x + B(u_1 + u_2) \\ \text{Or } \dot{x} &= A_1 x + Bu_2 + \omega_r (A_2 + Bk_1)x \end{aligned} \quad (32)$$

In order to get exact cancelation of the non-linear term,

$$A_2 + Bk_1 = 0 \tag{33}$$

$$\text{Or } A_2 = -Bk_1 \tag{34}$$

If k_1 is taken as

$$k_1 = \begin{bmatrix} 0 & l_{ds} & 0 & l_{ad} \\ -l_{qs} & 0 & -l_{aq} & 0 \end{bmatrix} \tag{35}$$

Then, equation (34) is satisfied.

Thus, equation (32) changes to the standard linear form

$$\dot{x} = A_1x + Bu_2 \tag{36}$$

Alternatively, one can choose,

$$u = (\omega_r - \omega_{d1})k_1x + u_2 \tag{37}$$

where ω_{d1} is a design constant, which can be chosen for a trade off between the linear and non-linear components of the control signal. Substituting equation (37) in (32),

$$\dot{x} = (A_1 + \omega_{d1}A_2)x + Bu_2 = A_d x + Bu_2 \tag{38}$$

Where

$$A_d = A_1 + \omega_{d1}A_2 \tag{39}$$

Thus, the system non-linearity is exactly cancelled. This linearization is valid for all operating points.

5. Results and Discussions

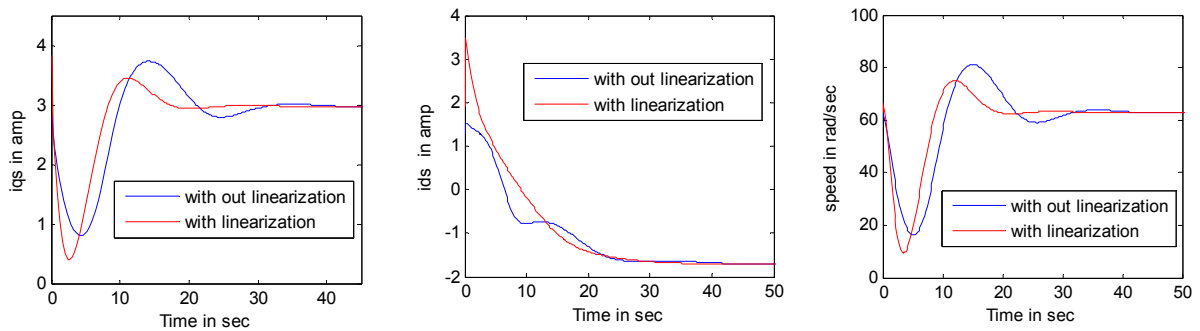

Figure 3. Simulation results of the state feedback controller with and without feedback linearization

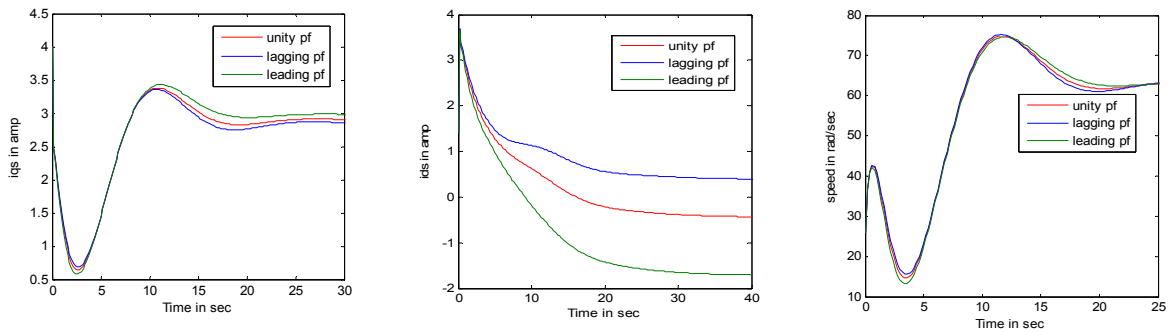

Figure 4. Simulation results of the drive system for different values of (i) $\delta = 8.735^\circ$ (unity pf) (ii) $\delta = 5^\circ$ (lagging pf) (iii) $\delta = 15^\circ$ (leading pf)

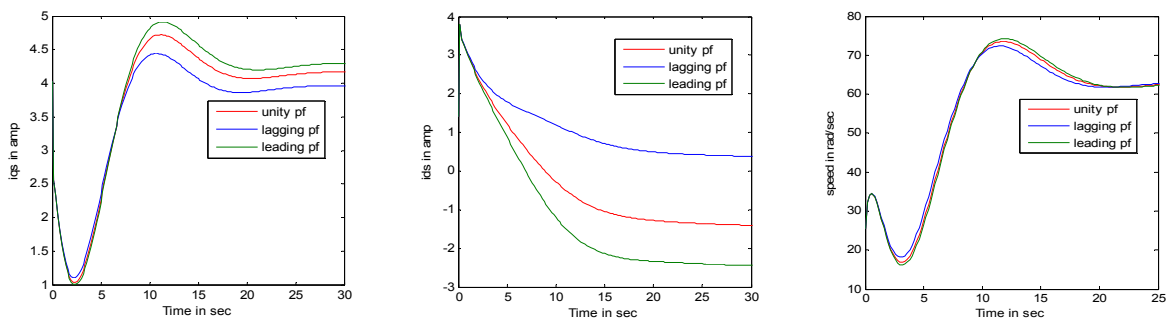

Figure 5. Simulation results of the drive system for different values of (i) $\psi = -19.1^\circ$ (unity pf) (ii) $\psi = 5^\circ$ (lagging pf) (iii) $\psi = -30^\circ$ (leading pf)

Figure 3 clearly shows that the transient responses have improved with feedback linearization. The initial overshoots in the currents are reduced and steady state values are achieved fastly with the non-linear controller. For a wider change in speed reference, the linear controller fails, but the proposed one continuous to work. The simulation results of the proposed controller as shown in Figure 4 for different values of δ , the currents are settled at different steady state values. Figure 5 shows the simulation results of the proposed controller for different values of Ψ resulting in variation of power factor from lagging to leading including unity. The currents are, however, not very sensitive to variation in ψ .

6. Conclusion

In this paper the design presupposes that the control system for the inner current loop acts much faster so that for all practical purposes, it can be considered to be instantaneous to the outer speed loop. A PI controller for speed loop has been designed by choosing suitable values of ζ and ω_n as specifications to obtain the desired speed response. The output of the PI controller is the reference torque, from which the reference currents are generated based on the specified values of the torque angle (δ) and the internal angle (ψ) of the motor. Simulation results clearly indicates that many shoots without exact feedback linearization bounding the system to be oscillatory when compared with the exact feedback linearization, though the final steady state values remain the same.

Appendix-A: Machine Ratings and Parameters

Machine Ratings and Parameters of Permanent Magnet Synchronous Motor (PMSM):

Motor specification	Value
Rated voltage	400V
Rated current	2.17A
Rated speed	1500rpm
Number of Poles	04
Rated power	1.2/1.5kW
Power factor	0.8/1.0
Viscous coefficient	0.0048N.m/sec/rad
Moment of Inertia	0.048kg.m ²

References

- [1] Pillay P, Krishnan R. Modeling of Permanent Magnet Motor Drives. *IEEE Transactions on Industrial Electronics*. 1988; 55(4):537-541
- [2] Pillay P, Krishnan R. Modeling, simulation and analysis of Permanent magnet motor drives, Part-I: The Permanent Magnet Synchronous Motor Drive. *IEEE Transactions on Industry Applications*. 1989; 25(2): 265-273.
- [3] Isidori A. Nonlinear control systems. German: Springer-verleg. 1989.
- [4] Ilic-Spong M, Marino R, Peresada SM, David G.Taylor. Feedback linearizing control of switched reluctance motors. *IEEE Transactions on Automatic control*. 1987; 32(5): 371-379.
- [5] KS Low, MF Rahman, KW Lim. *The dq Transformation and feedback linearization of a permanent magnet synchronous motor*. International Conference on Power Electronics and Drive Systems. 1995: 292-296.
- [6] Wu Z, Shen Y, Pan T, Ji Z. *Feedback linearization control of PMSM based on differential geometry theory*. 5th IEEE conference on Industrial Electronics and Applications. 2010: 2047-2051.
- [7] Zribi M, Chiasson J. Position control of PM stepper motor by exact linearization. *IEEE Transactions on Automatic Control*. 1991; 36(5): 620- 625.
- [8] Jun Zhang , Zhaojun Meng, Rui Chen, Changzhi Sun, Yuejun An. Decoupling control of PMSM based on exact linearization. *International Conference on Electronic and Mechanical Engineering and Information Technology*. 2011:1458-1461.
- [9] Parvathy AK, Rajagopalan D, Kamaraj V. Analysis and Application of Quadratic Linearization to the Control of Permanent Magnet Synchronous Motor. *International Journal on Electrical Engineering and Informatic*. 2014; 6(4): 644-664.
- [10] Safieh Izad, Mahmood Ghanbari. Speed Control of Permanent Magnet Synchronous Motor using Feedback Linearization Method. *Indian Journal of Fundamental and Applied Life Sciences*. 2015; 5(S1): 3293-3298.
- [11] Alice Mary K, Patra A, De NK, Sengupta S. Design and Implementation of the Control System for an Inverter-fed Synchronous Motor Drive. *IEEE Transactions on Control Systems Technology*. 2002; 10(6):853-859.
- [12] Blaschke F. The principle of field orientation as applied to the new TRANSVECTOR closed loop control system for rotating field machines. *Siemens Rev*. 1972; 34(2):217-220.
- [13] Hasirci U, Balikci U. *Non-linear and adaptive state feedback control of variable speed PMSM drives*. 7th IEEE Asian Control Conference. 2009: 605-1610.
- [14] Gang Liu, Cong Zhang. LQR Control of Permanent Magnet Synchronous Motor Based on Exact State Feedback Linearization. *International Review on Electrical Engineering*. 2013; 8(2): 626-632.
- [15] Ming Yin, Wang Cong, Jin Li, Lei Wang. *Optimal speed control of PMSM for electric propulsion based on exact linearization via state feedback*. IEEE International Conference on Information and Automation. 2010: 1972 – 1977
- [16] Zedong Zheng, Yongdong Li, Maurice Fadel. Novel Position Controller for PMSM Based on State Feedback and Load Torque Feed-forward. *Journal of Power Electronics*. 2011; 11(2): 140-147.
- [17] Bimbra PS. Generalized theory of Electrical machines. 4th edition: Khanna Publishers. 2004.
- [18] Bose BK. Modern Power Electronics and AC Drives: Beijing China machine press. 2005.
- [19] Krishnan R. Electric motor drives: Modeling analysis and control. 2nd edition: Prentice Hall of India. 2007.