

# Design and Implementation of the Application Layer Communication Protocol Based on Wireless Sensor Network

Changshun Chen

College of Information Engineering, Yangzhou Polytechnic College  
Wenchang west road 458, Yangzhou, Jiangsu, China, telp/fax:0514-87697092  
e-mail: 1025469638@qq.com

## Abstract

The user-defined communication protocol is the key step to develop application system based on Wireless Sensor Network. Through the analysis on the application of the wireless sensor network architecture and communication needs, a kind of simple and practical application layer communication protocol with detailed design of protocol data structure is proposed in this paper. Based on that, a communication protocol programming prototype is written in C# language. Through the test of wireless sensor network intelligent community monitoring system, it proves that the system data transmission based on this proposal is reliable and programming is simple and convenient.

**Keywords:** wireless sensor network, communication protocol, data structure, program prototype

Copyright © 2013 Universitas Ahmad Dahlan. All rights reserved.

## 1. Introduction

Wireless Sensor Networks (WSN) is a distributed network using wireless communication technology to realize information collection, transmission and processing [1-2]. In the study of Wireless Sensor Networks, data transmission method or protocol is always a research hotspot in this field, and communication protocol with simple and effective and easy programming is mostly hopeful to quickly build application system. In this paper, a simple communication model is established through analysis on the application of the wireless sensor network architecture and communication needs, and a programming prototype which can rapidly achieve application system is also designed.

## 2. Basic Framework of Application System

The typical application system of wireless sensor network is composed of a host machine, convergence gateway and control unit. The basic architecture can be seen in Figure 1.

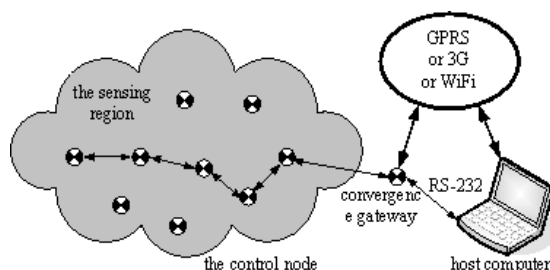

Figure 1. The Basic Architecture of Wireless Sensor Network

According to the demand of application, the control unit node is reasonably distributed in the control region. Control unit comprises two modules of the sensing and control, which can

be selected by software. Nodes automatically form a network through the network adaptive function and communicate with the convergence gateway through the “route hop” or “jump”. Convergence gateway is the distributing centre of measuring and controlling node data transmission. It on one hand transmits the control command from host machine to the control nodes and on the other hand, receives sensor data of each control node. Convergence gateway can be connected with the host computer through the RS-232 serial mode, GPRS, 3G, WiFi and broadband networks. The host computer receives the upload perception data of convergence gateway, and stores them into the database after analysis. These stored data can be presented to the managers in ordinary form or web mode for query, statistics and history tracking, and also can send control demand to realize the closed loop control of the specified object by gathering gateway starting control unit according to the management command [3-4].

### 3. Communication Protocol Architecture

Wireless sensor network is data-centric task network, the nodes of which using the identification number, commands and data transmission among nodes, convergence gateway and host machine are all dependent on the network communication protocol which includes the physical layer, data link layer, network layer, transport layer and application layer. The system structure is shown in Figure 2 [5-7].

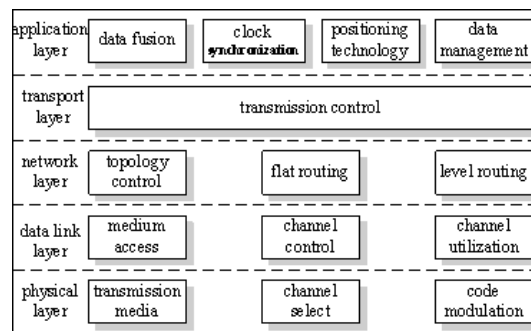

Figure 2. Wireless Sensor Network Communication Protocol Architecture

The application layer is closely related to the specific application and environment and design of which depends on the specific application demand. The main task of application layer is the acquisition of data and a preliminary treatment. The characteristics of basing on the data center and facing to the specific application require the WSN to quickly and effectively organize the information of each node and fusion to extract useful information directly to the users, instead of the traditional network addressing process. Meanwhile, in order to adapt to different network requirements, the function of clock synchronization, positioning technology and so on should also be considered [8-10].

### 4. Design of Application Layer Communication Protocol

Based on the above analysis, the main problems to solve for the application layer communication protocol in wireless sensor networks include two aspects, i.e., how to send collection and control command from host computer to nodes and how to return sensor data from nodes to host machine.

#### 4.1. Downlink Command Design

When the host computer sends command to coordinate gateway and then gateway sends it to control node, there are four factors should be considered. First is the difference of sensor data acquisition and actuator control, the second is the command execution node pointing and selection, the third is the physical differences between different actuator, and the

last one is programming and analysis convenience of command data package. Based on this, the downlink command data package structure is designed as shown in Table 1.

Table 1. WSN Downlink Command Packet Structure

Command head	Command type	Command name	Command address	Command parameter	Command tail
1	3	3	2	6	1
#	"WSN"	"R/T"+"XX" R: collect T: control	0x----	Null value replaced by 'N'	*

Command head: the beginning of identify command, fixed as ANSI symbol"#".  
 Command type: named as ANSI symbol "WSN" for wireless sensor network.  
 Command name: command detail content, for example: the noise sensor data acquisition, starting stepper motor etc.  
 Command address: the network node command directed to.  
 Command parameter: identification command used for command expansion.  
 Command tail: the end of identification command, fixed as ANSI symbol"\*".  
 According to the above protocol format, the downlink command for noise data acquisition, DC motor control, and RFID card control is shown in Table 2.

Table 2. WSN Downlink Command

command	value
Noise acquisition	#WSNRZS+node network address(2)+NNNNNN *
DC motor control	#WSNTZL+node network address(2)+turn(1)+speed(1)+NNNN*
RFID card control	#WSNTRF+node network address(2)+open or close RFIDreader control code(1)+NNNNN*

**4.2. Design of Upstream Return Data Package**

After the host machine sends collection and control command to WSN, nodes receive the command, analysis and execute it and return the results to the host computer. Two aspects information should be included in the return data package: one is whether the execution is successful; the other is, if successful, returning the collected sensor data in a specific format. The return data package design can be seen in Table 3.

Table 3. WSN Command Return Data Package Structure

Command head	Command type	Command name	Command status	Command address	Command return data	Command tail
1	3	3	1	2	21	1
#	"WSN"	"R/T"+"XX" R: collect T: control	S: success E: failure	0x----	Null value replaced by 'N'	*

Definition and command of return data package are similar. According to the above protocol rule, the result data return package from noise and RFID control node is listed in Table 4.

Table 4. WSN Command Return Data Package

command	Command return data package
Noise acquisition	#WSNRZS+node network address(2)+NNNNNN *
RFIDcard control	#WSNRZS+command status(1)+node network address(2)+ noise data(1)+ NNNNNNNNNNNNNNNNNNNNN*
RFID card control	#WSNTRF+command status(1)+node network address(2)+RFID card number data(16)+ NNNNN*

## 5. Application of the Application Layer Communication Protocol in the Monitoring and Management System of Intelligent Community

Based on the above communication protocol, a monitoring and management system of Intelligent Community with PC as host machine, CC2530 as the core to form the intelligent measurement and control node, ARM6410 as the core of setting up the coordination gateway, is developed. Host computer runs the monitoring and management program, convergence gateway is in charge of the establishment and management of WSN network, and the control nodes are responsible for the implementation of the sensing data collection and control command. Whether in PC or nodes, the method for programming the application layer protocol is similar, that is, firstly converting the user demand into the command of byte protocol specification, and then sending it from host PC to the convergence gateway, which analyze the command and start the acquisition or actuator of corresponding nodes control. After finishing the task, the collection result or the state of execution will be organized according to the protocol specification into data package and returned to the host machine. Finally, the host computer analyzes the acquired data package, separates the relevant information to display and store, compares the return results with the present value and determines the next command need to issue [8].

Limiting to the length of paper, only the core C# program in host computer relevant with application layer protocol is presented as flows, the programs in convergence gateway and control nodes are similar.

```
namespace WinFormMonitor
{
    public partial class Form_Monitor : Form
    {
        // Initialization, definition of process variables
        List<byte> dataList = new List<byte>();
        StringBuilder strBud = new StringBuilder();
        StringBuilder strBud1 = new StringBuilder();
        //form loading, serial port setting up and opening
        private void Form_Monitor_Load(object sender, EventArgs e)
        {
            s_Port.PortName = comPorts.Text;
            s_Port.BaudRate = int.Parse(comRate.Text);
            s_Port.Open();
        }
        //the host computer send downlink command to WSN through the serial prot.
        private void SendNetCmd(string s)
        {
            //transfer the command to the corresponding byte code
            List<byte> buf = new List<byte>();
            buf.Add(Convert.ToByte('#'));
            buf.Add(Convert.ToByte('R'));
            buf.Add(Convert.ToByte('Z'));
            buf.Add(Convert.ToByte('S'));
            buf.Add(Convert.ToByte(0x01));
            buf.Add(Convert.ToByte(0x00));
            buf.Add(Convert.ToByte('N'));
            buf.Add(Convert.ToByte('*'));
            //write the byte code command to the serial buffer
            s_Port.Write(buf.ToArray(), 0, buf.Count);
            timerMain.Enabled = true;
        }
        // when the serial port receives the return data from sensor node
        private void s_Port_DataReceived(object sender, SerialDataReceivedEventArgs e)
        {
            int n = s_Port.BytesToRead;
            byte[] buf = new byte[n];
            s_Port.Read(buf, 0, n);
        }
    }
}
```

```

this.Invoke((EventHandler)
{
    foreach (byte b in buf)
    {
        dataList.Add(b);
    }
}
}
// Regular inspection, analysis of serial port received postback data and corresponding
treatment
private void timerMain_Tick(object sender, EventArgs e)
{
    for (int i = 0; i <= record.Count - 1; i++)
    {
        // Check the command type
        for (int j = 5; j <= 7; j++)
        {
            strBud1.Clear();
            strBud1.Append(record [i][j].ToString());
            ComType += strBud1.ToString;
        }
        // Check the command execution status
        for (int j = 8; j <= 8; j++)
        {
            strBud1.Clear();
            strBud1.Append(record [i][j].ToString());
            ComState += strBud1.ToString();
        }
        // The corresponding treatment according to the results of analysis
        if (DatType == "5A5353") //noise
        {
            for (int j = 10; j <= 10; j++)
            {
                strBud1.Clear();
                strBud1.Append(record [i][j].ToString());
                zsData += strBud1;
            }
            zs = (Convert.ToDecimal(zsData)).ToString();
            listView1.Items.Add(new ListViewItem(new string[] { netAdr, zs }));
        }
    }
}
}
}
}

```

## 6. Conclusion

System structure of communication protocol for Wireless Sensor Networks is studied in the view of developing wireless sensor network application system in this paper. A application layer communication protocol based on architecture model of host machine, coordinate gateway, and control node is designed and the detailed programming scheme and prototype is also given. Through the practical application of wireless sensor network in intelligent community monitoring system, it is confirmed that this scheme is convenient in programming, reliable in communication and stable in system.

The application layer protocol for wireless sensor network designed in this paper has good portability and scalability. On the basis of maintaining the overall scheme of the protocol, with slight adjustment and expansion on the reservation, it can be applied in a variety of application fields and then the intelligent application system based on wireless sensor network can be quickly developed.

**References**

- [1] Atzori L, Ieraand A, Morabito G. The Internet of things: A survey. *Computer Network*. 2010; 54(15): 2787-2805.
- [2] Ruiling Liu, Xianglin Li. Summary of wireless sensor network research and Application. *Computer application technology*. 2010; 6(12): 3093-3094.
- [3] Changlin Shu et al. Method for wireless sensor network component development. *Micro computer information*. 2010; 26(3-2): 30-32.
- [4] Endong Tong et al. Service construction and concurrency control of sensor network. *Journal of electronic science and technology university*. 2011; 40(3): 322-332.
- [5] Xiang Chen. Research on security strategy based on Wireless Sensor Network. *Digital technology and application*. 2010; 5.
- [6] GUO L W, LIU D H, ZHANG X L, et al. Design of intelligent detecting system based on wireless transmission. *Journal of Hejiang University (SCIENCE A)*. 2007; 8(3): 490-494.
- [7] Li Baozhu, Wang Hui. A low complexity localization algorithm in wireless sensor network. *Innovative Computing & Communication*. 2010: 1260-1264.
- [8] WON-SUK J, WILLIAM M, MIROSLAW J. Wireless sensor networks as part of a web-based building environmental monitoring system. *Automation in Construction*. 2008; 17(3): 29-736.
- [9] Babak Namazi. EnergyEfficient MultiSPEED Routing Protocol for Wireless Sensor Networks. *International Journal of Electrical and Computer Engineering (IJECE)*. 2013; 3(2).
- [10] Chin-Yuan Hsieh. Prediction of Forest Temperature Microchange by Wireless Sensor Network Technology. *International Journal of Electrical and Computer Engineering (IJECE)*. 2012; 2(5): 632-638.