

A New Regularity to Generate High-dimensional Hyperchaotic System

Jianming Liu

Hebei Key Lab of Industrial Computer Control Engineering, Yanshan University, Qinhuangdao, China
e-mail: ppkkkk@126.com

Abstract

The chaotic system plays an important role in information communication, electrical equipment, computer cryptography and so on. In this paper, four new high-dimensional complex hyperchaotic systems are found. A new overlaying regularity to generate a new high-dimensional complex hyperchaotic system is found by overlaying a series of low-dimensional chaotic system with the Duffing chaotic system. The regularity to generate high-dimensional complex hyperchaotic system is analyzed. The features of chase space maps and Lyapunov exponents' maps are analyzed. The results of theoretical analysis and experiment show that new systems having strong chaotic features.

Keywords: electrical equipment, cryptography, complex chaos, high-dimensional chaos

Copyright © 2013 Universitas Ahmad Dahlan. All rights reserved.

1. Introduction

The theory of relativity, the chaotic phenomenon and the quantum mechanics are three important scientific discoveries in the 20th century [1]. The chaotic phenomenon is widespread in information communication field [2]. There often were some noises in the electrical equipment and communication [3]. Those noises were some uncertain messy output waveform [4]. In the past, they were generally considered to be due to the circuit to generate self-excited oscillation and noises. In fact, in many cases, the circuit was in a chaotic state. Therefore, to understand the chaotic phenomenon and its produced regularity in electrical equipment and communication has important significance [5]. Because the outputs of chaotic system is very sensitive to the changes of initial conditions and has the andrandom characteristics that encryption required, it has become an important branch of researching for the information security [6].

To any chaotic information encryption, the higher dimension it has, the better security it has. Now, only a few of five-dimensional complex chaotic systems have been found. By adding the state feedback controller on low-dimensional chaotic systems, some five-dimensional hyperchaotic systems are generated. For example: in 2009, Huaqing Li added state feedback on the three-dimensional Lorenz system to generate a five-dimensional Lorenz hyperchaotic system [7]. In 2010, Feng Han added state feedback on the three-dimensional Lu chaotic system to generate a five-dimensional Lu hyperchaotic system [8]. In 2011, Lu Huang added state feedback on the three-dimensional Chen chaotic system to generate a five-dimensional Chen hyperchaotic system [9]. In this paper, we will study how to generate a six-dimensional complex hyperchaotic system and explore the law to generate high-dimensional complex hyperchaotic system. The result of this study will further reveal the operation mechanism of the high-dimensional hyperchaotic oscillation circuits. The result of this research will has practical significance in cryptography, communication, electronic and electrical equipments.

2. New Duffing-Lorenz Chaotic System

2.1. The Form of the Duffing-Lorenz Chaotic System

Duffing system has rich nonlinearity dynamics characteristics [10]. It is one of the commonly used system in information transmit field. Duffing system is as the following:

$$\begin{cases} \dot{x} = y \\ \dot{y} = -dy - x^3 + e \cos wt \end{cases} \quad (1)$$

D and e are real constants. The form of the Lorenz system is as the following:

$$\begin{cases} \dot{x} = a(y - x) \\ \dot{y} = bx - xz - y \\ \dot{z} = xy - cz \end{cases} \quad (2)$$

The parameters of a~c are real constants. Equation (1) and Equation (2) are overlaid into a new Duffing-Lorenz complex hyperchaotic system:

$$\begin{cases} \dot{x} = a(y - x) + dzu - w \\ \dot{y} = cx - xz - y \\ \dot{z} = xy - bz \\ \dot{u} = v \\ \dot{v} = -ev - u^3 + f \cos(w) \\ \dot{w} = gx \end{cases} \quad (3)$$

The parameters of a~g are real constants.

2.2. Phase Space

The phase spaces of Duffing Lorenz complex hyperchaotic system are shown in Figure 1.

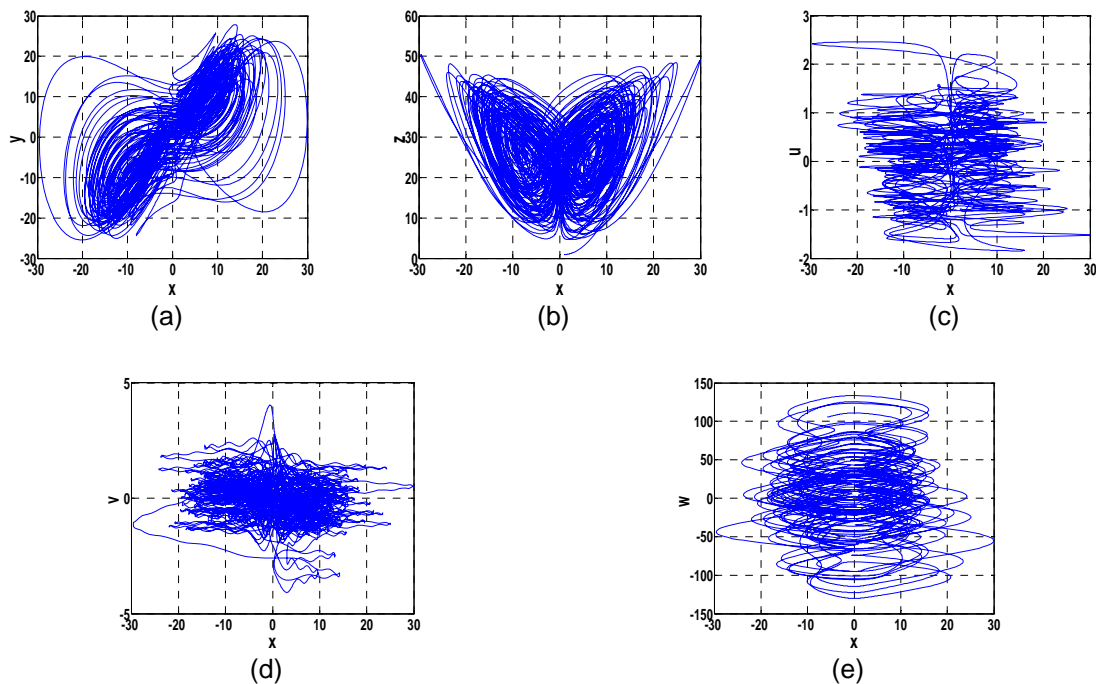

Figure 1. Phase Space Pictures (a) x-y, (b) x-z, (c) x-u, (d) x-v, (e) x-w

2.3. Lyapunov Exponent Analysis

In the baseline parameters of $a=10$, $b=8/3$, $c=28$, $d=-2.5$, $e=0.6$, $f=-8$, $g=9.7$, $x=1$, $y=1$, $z=1$, $u=1$, $v=1$, $w=1$ and $dt=0.005$, the Lyapunov exponents [11] with the parameters change are shown in Figure 2(a)-(g).

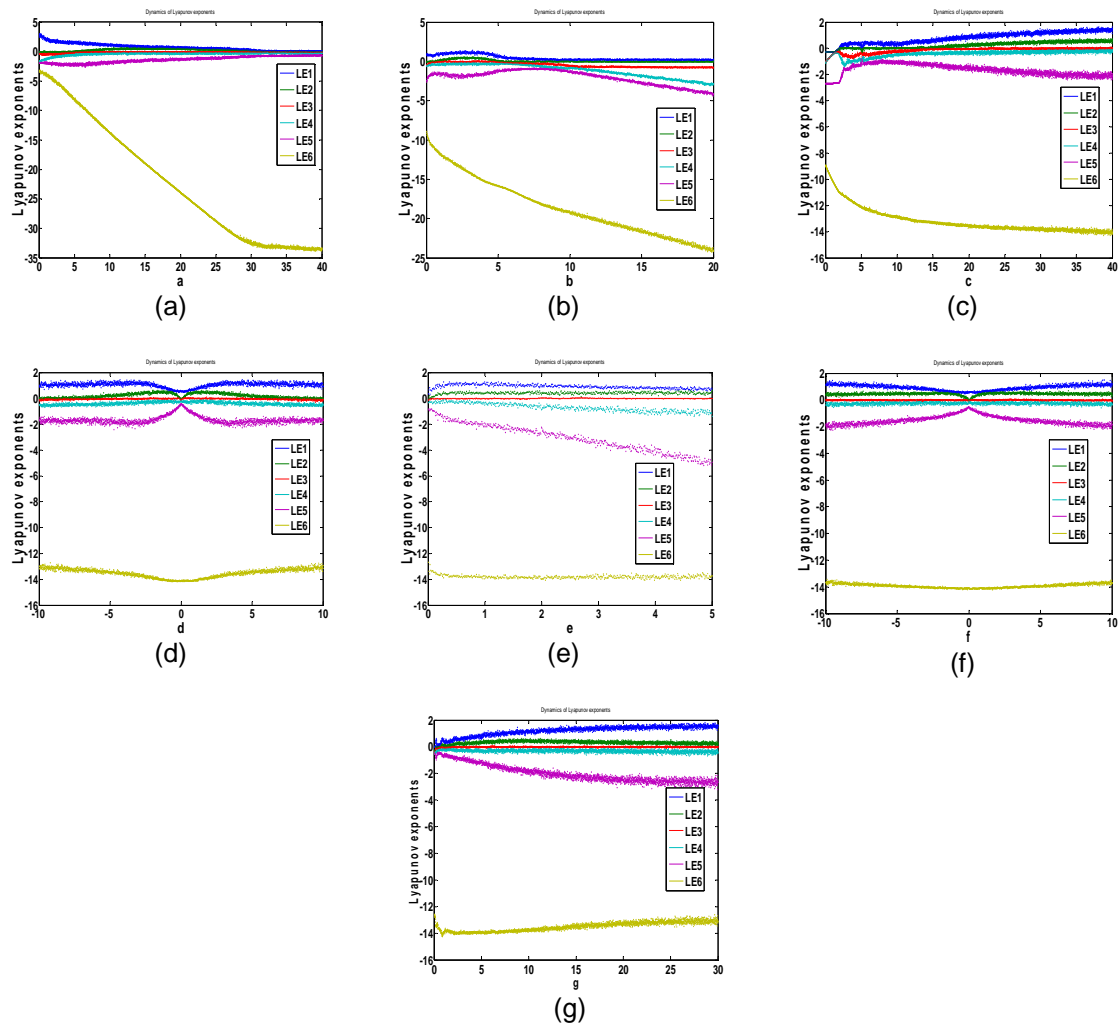

Figure 2. Lyapunov Pictures (a) a change, (b) b change, (c) c change, (d) d change, (e) e change, (f) f change, (g) g change

The results of the experiment show the steady state, the chaotic state and the hyper chaotic state when the parameters change of the Duffing-Lorenz chaotic system. When there are two positive Lyapunov exponents in the same time, the system of Duffing-Lorenz complex chaotic is in the hyperchaotic state.

2.4. Power Spectrum Analysis

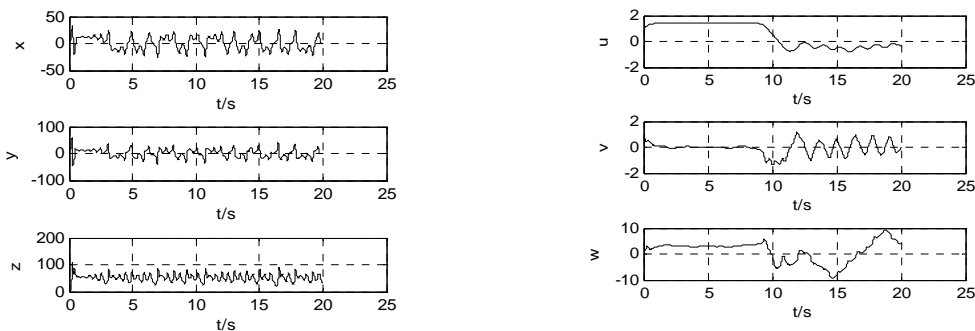

Figure 3. System Time-domain Waveform

The time-domain waveform of chaotic system is similar periodicity. The power spectrum waveform of the cycle signal is discrete. The power spectrum waveform of non-periodic signal is continuous and smooth. The power spectrum waveform of chaotic system is continuous and has a number of peaks. The power spectrum waveform and time-domain waveform of Equation (3) are shown in Figure 3 and Figure 4.

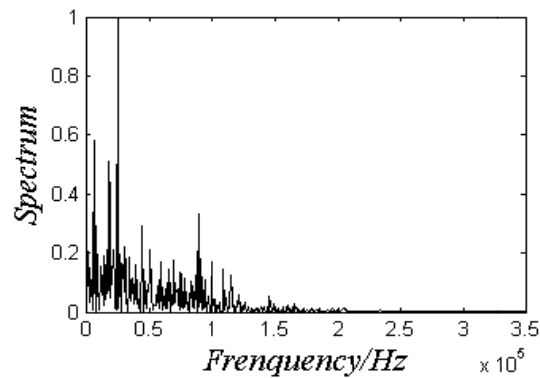

Figure 4. The Power Spectrum Waveform

The waveforms of Figure 3 and Figure 4 show that they have the chaotic characteristics.

3. New Duffing-Lu Chaotic System

3.1. The Form of the Duffing-Lu Chaotic System

Lu chaotic system is as the following:

$$\begin{cases} \dot{x} = a(y - x) \\ \dot{y} = -xz + cy \\ \dot{z} = xy - dz \end{cases} \quad (4)$$

The parameters of a ~ c are real constants. The external excitation part of the Duffing system is replaced by an autonomous part and the positive feedback is introduced. Then, Equation (1) and Equation (4) are overlaid into a new Duffing-Lu complex hyperchaotic system.

$$\begin{cases} \dot{x} = a(y - x) + bw \\ \dot{y} = -xz + cy \\ \dot{z} = x^2 - dz \\ \dot{u} = v \\ \dot{v} = -ev - u^3 + f \cos(w) \\ \dot{w} = gyz \end{cases} \quad (5)$$

The parameters of a ~ g are real constants.

3.2. Phase Space

The phase spaces of Duffing-Lu complex hyperchaotic system are:

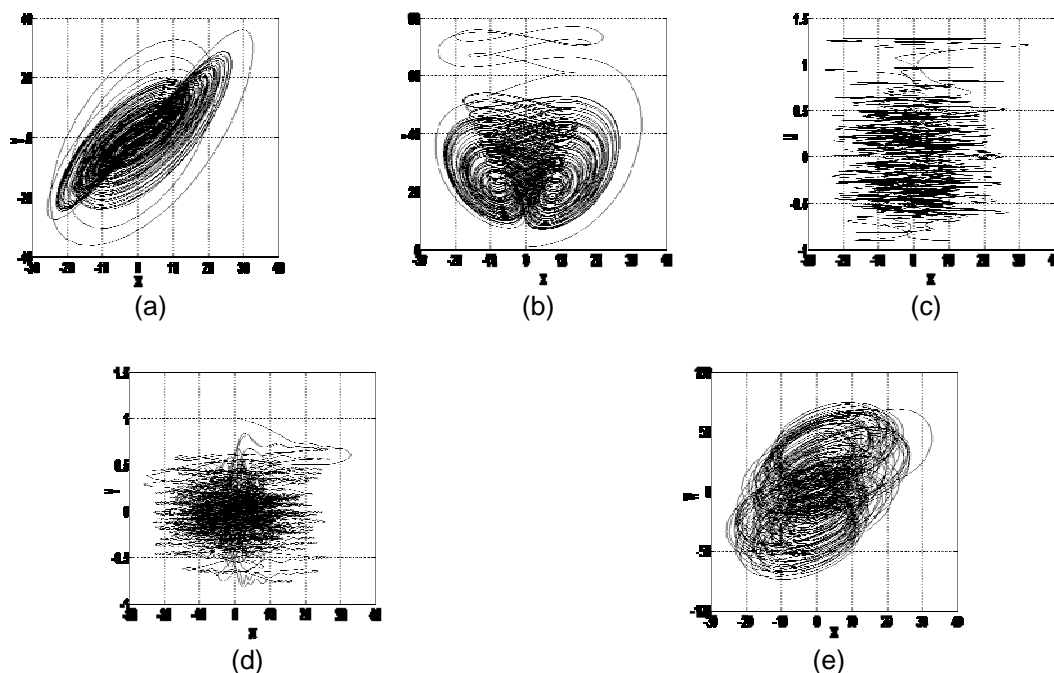

Figure 5. Phase Space Pictures (a) x-y, (b) x-z, (c) x-u, (d) x-v, (e) x-w

3.3. Lyapunov Exponent Analysis

When the initial conditions are $a=36$, $b=1$, $c=20$, $d=3$, $e=0.6$, $f=3$, $g=1$, $x=1$, $y=1$, $z=1$, $u=1$, $v=1$, $w=1$ and $dt=0.005$, the Lyapunov exponents are 1.22, 0.16, -0.38, -0.54, -1.17 and -18.85. Since there are two positive Lyapunov exponents, the system of Equation (5) is in the hyperchaotic state.

4. New Duffing-Chen Chaotic System

4.1. The Form of the Duffing-Chen Chaotic System

The form of Chen chaotic system is:

$$\begin{cases} \dot{x} = a(y - x) \\ \dot{y} = (c - a)x - xz + cy \\ \dot{z} = xy - bz \end{cases} \quad (6)$$

Equation (1) and equation (6) are overlaid into a new six-dimensional Duffing-Chen complex hyperchaotic system:

$$\begin{cases} \dot{x} = a(y - x) + gv \\ \dot{y} = (b - a)x - xz + hy + w \\ \dot{z} = xy - cz \\ \dot{u} = v \\ \dot{v} = -dv - u^3 + e \cos(w) \\ \dot{w} = fxv \end{cases} \quad (7)$$

The parameters of a-h are real constants.

4.2. Phase Space

The phase spaces of Duffing-Chen complex hyperchaotic system are:

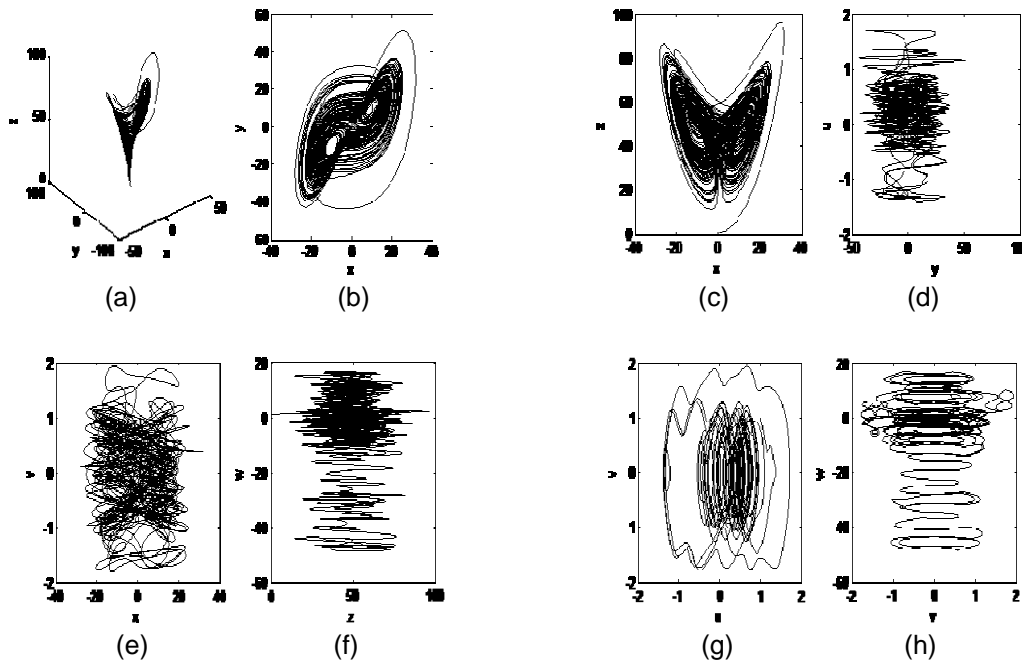

Figure 6. Phase Space Pictures (a) x-y-z, (b) x-y, (c) x-z, (d) y-u, (e) x-v, (f) z-w, (g) u-v, (h) v-w

4.3. Lyapunov Exponent Analysis

When the parameters are $a=10$, $b=55$, $c=8/3$, $d=0.6$, $e=-3$, $f=1$, $g=3$, $h=1$, $x=1$, $y=1$, $z=1$, $u=1$, $v=1$, $w=1$ and $dt=0.005$, the Lyapunov exponents are 0.970, 3.108, -1.468, -0.461, -3.574 and -10.829. The system is in the hyperchaotic state.

5. The Regularity to Generate High-dimensional Chatic System

By the analysis of three kinds of the new six-dimensional hyperchaotic system, it is discovered that the external excitation part of the original Duffing system of Equation (1) is replaced by an autonomous part and the appropriate parametric positive feedback controller is added. Then, by the bridge of the autonomous part, the Duffing chaotic system and three-dimensional chaotic system are combined into a new six-dimensional complex hyperchaotic system. The overlaying regularity is composed by three parts. The upper part is low-dimensional chaotic system and the parameters feedback of f_1 . The middle part is Duffing system. The lower part is external excitation part. By selecting the parameters feedback of f_1 and the f_2 , a series of the new high-dimensional complex hyperchaotic system can be generated. The new overlaying regularity of complex hyperchaotic system is shown in Figure 7.

upper part : another chaotic system + f1
middle part : duffing chaotic system
lower part : + f2

Figure 7. The Overlaying Regularity

6. The Verify of Regularity

6.1. The Complex Chaotic System

Chebyshev chaotic system is as the following:

$$x_{n+1} = \cos(k \cos^{-1}(x_n)), -1 \leq x_n \leq 1 \tag{8}$$

K is real constant. To verify the validity of the overlaying regularity, a new Duffing-Chebyshev chaotic system is constructed based on the above mentioned overlaying regularity. The external excitation part of Duffing system is replaced by an autonomous part and the positive feedback controller is introduced. Then, by selecting the parameters, the Chebyshev chaotic system and the Duffing chaotic system are overlaid into a new hyperchaotic system.

$$\begin{cases} \dot{x} = \cos(f \cos^{-1}(\sin(w))) \\ \dot{u} = v \\ \dot{v} = -dv - u^3 + e \cos(w) \\ \dot{w} = auv + b(w - cx) \end{cases} \tag{9}$$

The parameters of a~f are real constants. When a=0.09, b=25, c=1, d=1, f=1, g=3, h=15, x=0, u=0, v=0, w=0, dt=0.005 and e=3.9 or e=4.1, the phase space pictures of four-dimensional Duffing-Chebyshev complex hyperchaotic system are shown in Figure 8(a)-(b).

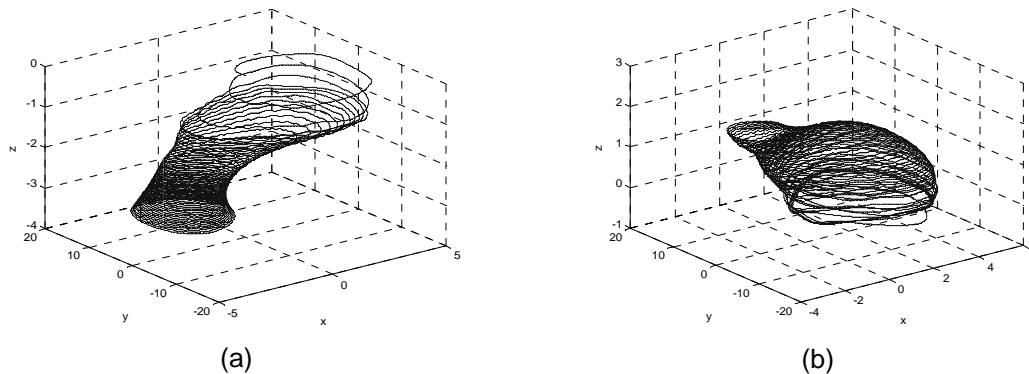

Figure 8. Phase Space Pictures (a) e=3.9, (b) e=4.1

6.2. Lyapunov Exponent Analysis

When a=0.09, b=25, c=1, d=1, e=4, f=1, g=3, h=15, x=0, u=0, v=0, w=0 and dt=0.005, the new complex system is sometimes in the hyperchaotic state as shown in Figure 9.

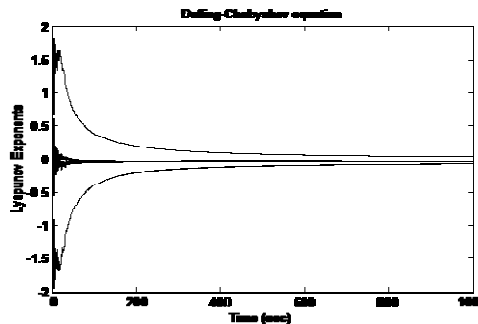

Figure 9. Lyapunov exponent

7. Conclusion

Now, the five-dimensional complex hyperchaotic systems have been built by adding the feedback controller to a three-dimensional chaotic system. In this paper, there are three new six-dimensional complex hyperchaotic systems and a new four-dimensional complex hyperchaotic system to be found. A new overlaying regularity is found by overlaying a series of low-dimensional chaotic system and the Duffing chaotic system to generate a new high-dimensional complex chaotic system. The results of theoretical analysis and experiment reveal the relationship between the low-dimensional chaotic system and the high-dimensional complex hyperchaotic system. The result of this research has practical significance to analyze and design the high-dimensional chaotic system in communication, electrical equipment, computer cryptography and so on.

Acknowledgments

The work was supported by the 2012 Natural Science Foundation of the Hebei Province, China (F2012203088).

References

- [1] Weijian Ren, Chaohai Kang, Yingying Li, Liying Gong. Chaotic Immune Genetic Hybrid Algorithms and Its Application. *TELKOMNIKA*. 2013; 11(2): 975-984.
- [2] Teddy Mantoro, Andri Zakariya. Securing E-mail Communication Using Hybrid Cryptosystem on Android-based Mobile Devices. *TELKOMNIKA*. 2012; 10(4): 827-834.
- [3] Wu Zhu, Qi Ding, Weiya Ma, Y Gui, Huafu Zhang. Research on High Frequency Amplitude Attenuation of Electric Fast Transient Generator. *TELKOMNIKA*. 2013; 11(1): 97-102.
- [4] Gao Qiang, Yan Hua, Yang Hongye. The Research of Chaos-based M-ary Spreading Sequences. *TELKOMNIKA*. 2012; 10(8): 2151-2158.
- [5] Zhang Wei. The Electromagnetic Interference Model Analysis of the Power Switching Devices. *TELKOMNIKA*. 2013; 11(1): 167-172.
- [6] Jinhui Sun, Geng Zhao, Xufei Li. An Improved Public Key Encryption Algorithm Based on Chebyshev Polynomials. *TELKOMNIKA*. 2013; 11(2): 864-870.
- [7] Li Huaqing, Luo Xiaohua, Dai Xiangguang. A hyperchaotic system and its synchronism projection. *Acta Electronica Sinica*. 2009; 37(3): 654-657.
- [8] Han Feng, Tang Jiashi. Dynamical Behaviors of Five dimensional Controlled Chaotic System. *Journal of dynamics and control*. 2010; 8(3): 250-253.
- [9] Huang Lu, Tang Jiashi. Analysis of Circuit Realization and Controlling Method of the Fifth Dimension Chen System. *Journal of Hainan Normal University*. 2011; 24(3): 283-287.
- [10] Nie Chunyan. Chao system and weak signal check. Beijing: Qinghua Press. 2009: 9-21.
- [11] Yu WB. Experiment and Analysis of Chaotic Computation. Beijing: Science Press. 2008: 26-39.