

MATLAB based design and performance analysis of electronically commutated BLDC motor

Issa Etier¹, Anci Manon Mary A.², Nithiyananthan Kannan³

¹Department of Electrical Engineering, Hashemite University, Zarqa, Jordan

²Department of Electrical and Electronics Engineering, Karpagam College of Engineering, India

³Department of Electrical Engineering, Faculty of Engineering, Rabigh, King Abdulaziz University, Saudi Arabia

Article Info

Article history:

Received Mar 11, 2021

Revised Aug 5, 2021

Accepted Aug 13, 2021

Keywords:

Brushless direct current motor
Fractional order proportional
integral derivative controllers
Proportional integral derivative
controllers

ABSTRACT

The main objective of this research work is to design the electronically commutated brushless direct current (BLDC) motor and analysis its performance in MATLAB environment. The use of BLDC engine is expanding daily, the performance analysis is progressively significant and the consumer loyalty is significant. In light of the ranking and requirements, the BLDC engine is planned. The BLDC motor is widely used in a variety of fields. Low ripple input supply and a suitable speed controller are needed to achieve desired motor output. The output of BLDC motors, such as torque, voltage, and speed response, is examined in this paper. The controller parameters have been fine-tuned to improve motor speed. It has been discovered that a three phase voltage source inverter (VSI) fed BLDC motor with a fractional-order proportional-integral-derivative (FOPID) controller provides superior BLDC motor response. The outcomes are broke down utilizing the MATLAB programming.

This is an open access article under the [CC BY-SA](https://creativecommons.org/licenses/by-sa/4.0/) license.



Corresponding Author:

Nithiyananthan Kannan

Department of Electrical Engineering, Faculty of Engineering, Rabigh

King Abdulaziz University

Jeddah, Saudi Arabia

Email: nmajaknap@kau.edu.sa

1. INTRODUCTION

The brushless direct current (BLDC) is likewise as the perpetual magnet BLDC motor additionally as poly or several stage engines. Electronic controller is the main part of this magnet BLDC motor. In this way, a BLDC motor impels the framework that will come together into single alternating current (AC) engine, a rotor position sensor and strong state inverter. The transistor utilizes for small power drives and thyristors for high force drives by the strong state inverter. Rotor position sensor screen the pole imparts the control sign for regulating on the controlled switches of the state inverter in the proper grouping. The transistor uses for little force drives and thyristors for high power drives by the solid state inverter. Rotor position sensor screen the post gives the control sign for managing of the state inverter in the proper grouping [1]-[5].

The BLDC motor was not having any brushes in the commutator and brushes are disposed from the motor. An issue of substitution is understood utilizing the electronic recompense. An attribute of the BLDC engine was pretty much like the regular direct current (DC) engine, the compensation for the brushless DC engine is finished by detecting and exchanging which is of a few kinds. This motor will detect attractively and exchanging was done by power transistors. In this way, the phase commutation and torque ripple generation method can be obtained.

A BLDC motor framework ought to have the speed-torque attributes of the customary direct current perpetual magnet engines. The speed torque attributes of regular DC engine subsequently the BLDC motor have similar qualities. A controllable AC engine framework relies upon a variable recurrence, variable air conditioning voltage, which must be facilitated with the small speed to create a controllable slip recurrence current in windings of rotor, in light of fact a transformer can be viewed from the rotor-stator structure, and this doesn't function admirably in small frequencies. These are crucial distinction between AC motor and BLDC motor. In view of the fact that the field torque was created with association of an attractive field delivered by a lasting magnet rotor, and attractive field because of a DC in a stator structure [6]-[9].

Inside little engine the center rotor part obtains the immediate torque pole is legitimately associated with it. A rotor needs to approach the use of spiral channels in the ventilating pipes. The utilization of hub pipes is to create the way stream to outspread of the channels. The push ring is utilized for the cooling reason on the rings. Push rings are mostly utilized on pivotal channels. Because of absence of commutator portions, brushes have to adapt permanent magnet rotor. Here rotor was comprised with strong barrel shaped mellow steel. Because it is an electronic engine electronic compensation is utilized rather than commutating the armature current utilizing brushes. Two types of windings are dealt with precisely the equivalent, albeit some affordable controllers are intended to peruse potential difference between basic focal point with star associated winding. MATLAB based simulation has been implemented for the performance analysis of the proposed work. Similarly, many software tools have played a major role in the analysis of the applications of electrical power analysis and reported [10]-[25].

2. BRUSHLESS DIRECT CURRENT ENGINE

The activity of BLDC motor is comprising of three sections namely (I) modeling (ii) controller (iii) inverter. In every electronic application proportional integral and derivative controller is utilized cautiously for ideal yield and precise one. For regulating the framework proportional-integral-derivative (PID) controller is utilized generally, procedure associated with the controller is to obtain the three factors and the increasing accomplished was done by regulating the modes of the three factors are proportional, integral and derivative. Different control arrangements techniques are designed for controlling of speed plan of brushless direct current motor. Be that as it may, particle swarm optimization (PSO) fractional-order proportional-integral-derivative (FOPID) controller algorithm is a simple execution, adaptable and profoundly dependable. This framework gives the second order system by PSO and was created with utilizing derivative controller and fractional order proportional integral. For speed control of BLDC motor the derivative controller and fractional order proportional integral has been utilized. The general diagram of BLDC is shown in Figure 1. Here performance analysis of the BLDC motor utilizing derivative controller and proportional integral is examined and simulated. The analysis of BLDC motor as torque speed, harmonics, stator voltage and current has been examined utilizing the MATLAB programming.

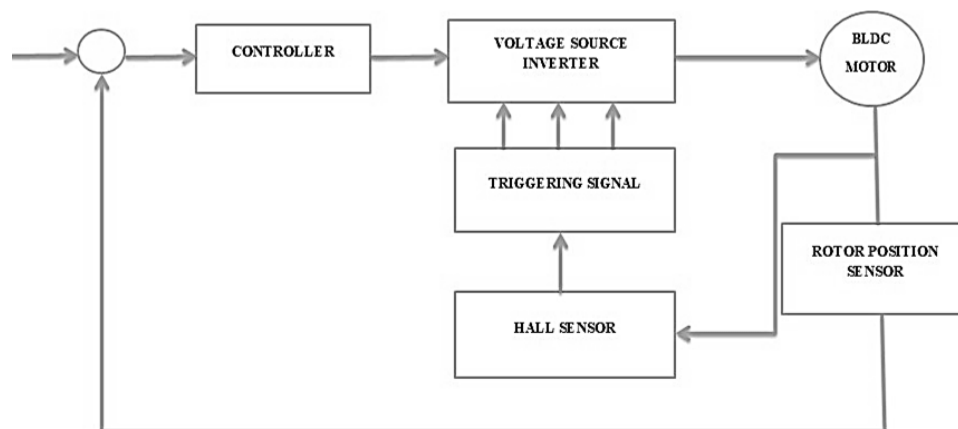

Figure 1. General diagram of BLDC

3. SENSORS AND SWITCHES

The magnitude and polarity of the magnetic field is detected by sensor with the help of hall effect sensing system. Logic compatible signal levels are formed by amplification of signals. The sensors are used to sense the same of the permanent magnet magnetic field in the air gap and are fixed on the stator side of the

motor. The yield of the control to the logic of the controller function setup to give current to suitable coil in the stator and the framework can give pay to armature reaction effect which is noticeable in structure.

An electrical optical switch is nothing but combination of the photo transistor and the light-emitting diode (LED). An electro optical switch is nothing but angular sensing. The shutter mechanism controls transmission of light in sensor and transmitter. The place of the shaft in the engine was decided by the sensor, and gives data change to the logic circuit. It changes over place sign into a power sign, and afterward controls the stage change in the stator winding. So many sorts of sensors are there and has its individual qualities.

4. PID AND FOPID

The best possible outcome is required from the shut circle framework to get the reasonable outcome. So, to get exact outcome the corresponding basic and the subsidiary blend was coordinated and the exhibition was examined. The block diagram of PID is shown in Figure 2. The exchange capacity of corresponding indispensable and subordinate is required and it is referenced underneath,

$$c(s) = K_p \left[1 + \tau_d s + \frac{1}{\tau_i s} \right]$$

The low order of controller was picked for the worldwide appropriate, by the low order it very well may useful in semantic instance-salient object (SISO) framework. A loop is planned by the two controllers from single input single output framework, then numerous inputs multiple output loop is formed. The primary purpose behind utilizing these controllers is tremendous; hence likewise it is utilized within enterprises. In the specific function the procedure have to regulate for different level for the controller has utilized. The significant is picking factors in PID controller. On the off chance that any procedure is turned out badly the stability of the system will be changed and closed loop system will be unpredictable.

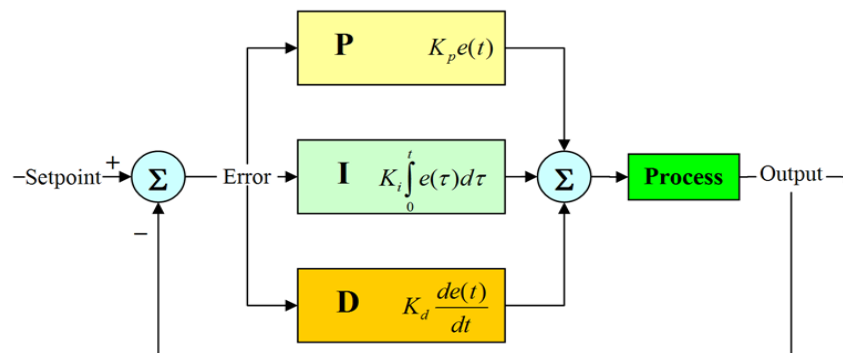

Figure 2. Block diagram of PID

The advent of fractional calculus in recent years has enabled the transition from classical models and controllers to those represented by non integer order differential equations. Fractional-order dynamic models and controllers were developed as a result. The control flow of fractional order PID is shown in Figure 3. Previous research works had suggested a parallel version of the fractional-order PID controller. The fact that these controllers have two additional "tuning knobs" that can be used to change the control law in a way that benefits the control loop is driving interest in using fractional-order (FO) PID controllers in the industry the graphical representation representation of fractional order PID is shown in Figure 4.

$$G_c(s) = U(s)E(s) = K_p + K_i s^{-\lambda} + K_d s^\mu$$

Where $(\lambda, \mu) > 0$.

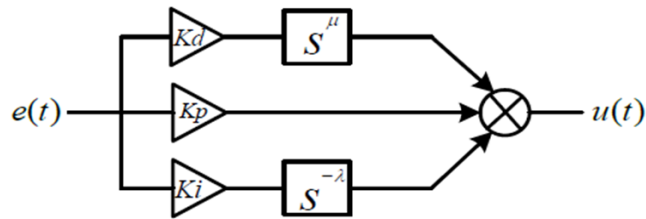

Figure 3. Control flow of fractional order PID

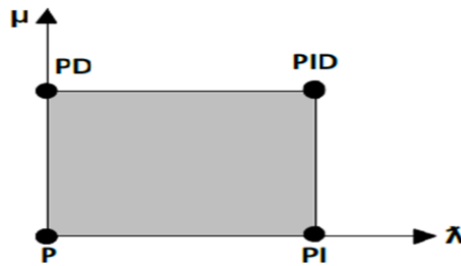

Figure 4. Graphical representation of fractional order PID

5. RESULTS AND DISCUSSION

The inverter block, current block, torque block, back EMF block are the four key components of the BLDC motor drive simulation model. It has been shown in Figure 5. The output of BLDC motor with FOPID is shown in the Figures 6-8. The phasor voltage of BLDC motor with FOPID is shown in Figure 6. The speed response of PID and FOPID is shown in Figure 7, from the Figure 7 it is clearly shown that FOPID is superior to PID. The torque of BLDC motor with FOPID is shown in Figure 8.

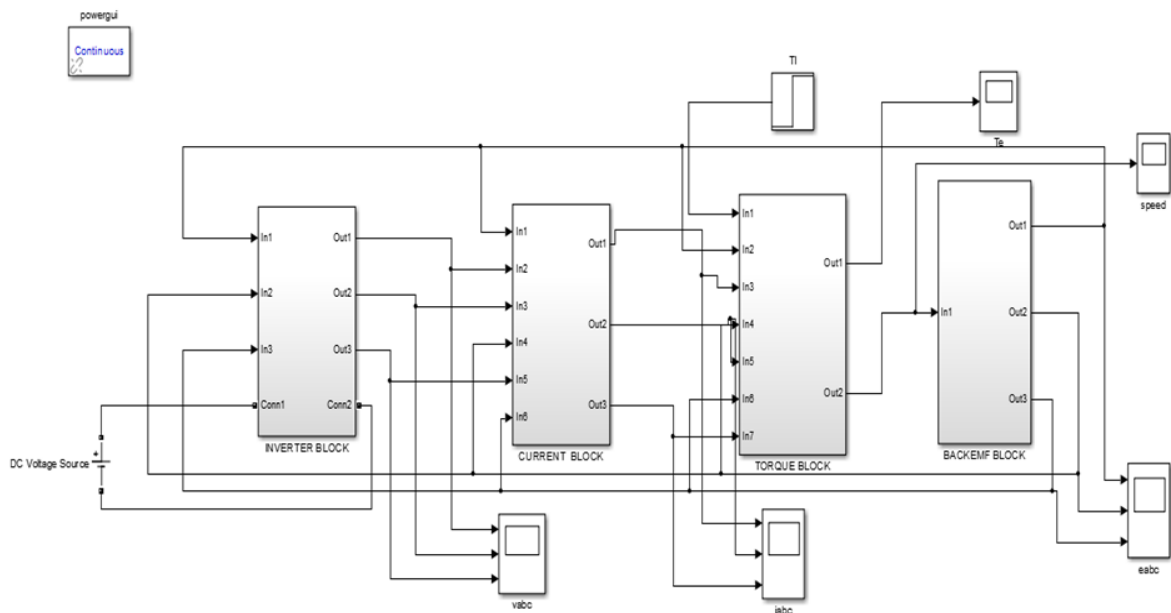

Figure 5. Simulation diagram

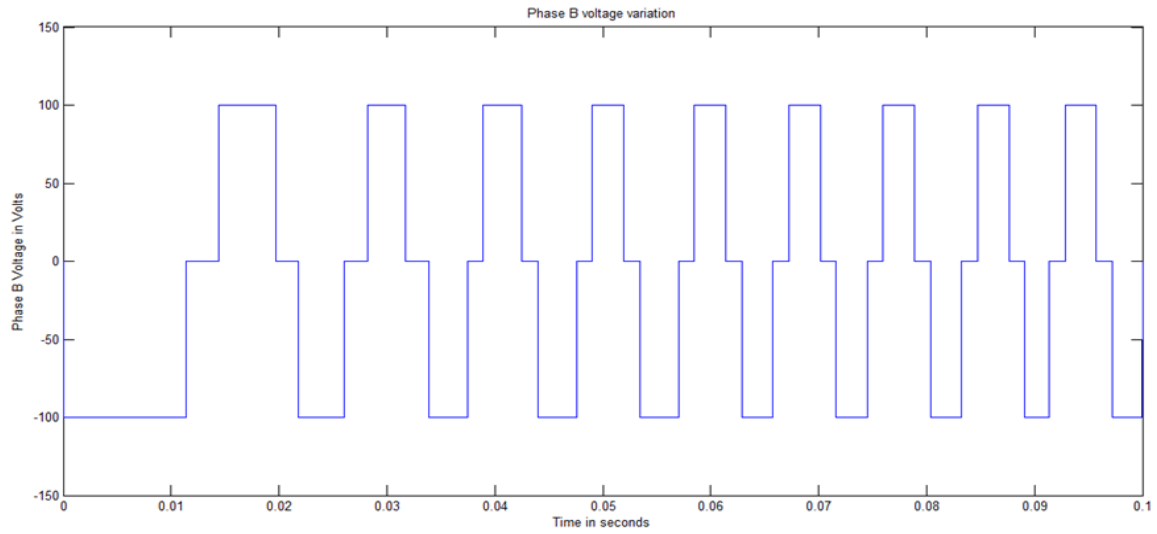

Figure 6. Output of BLDC motor (phasor voltage)

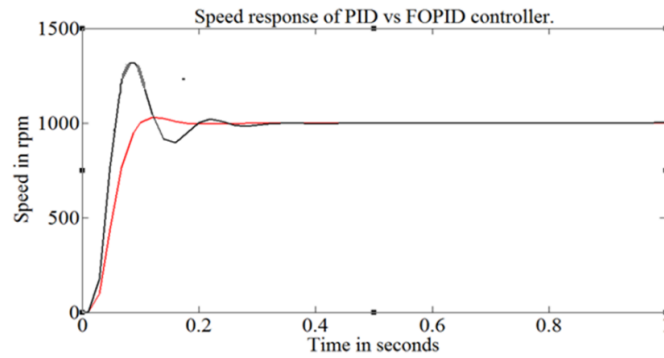

Figure 7. Speed response of PID and FOPID controller

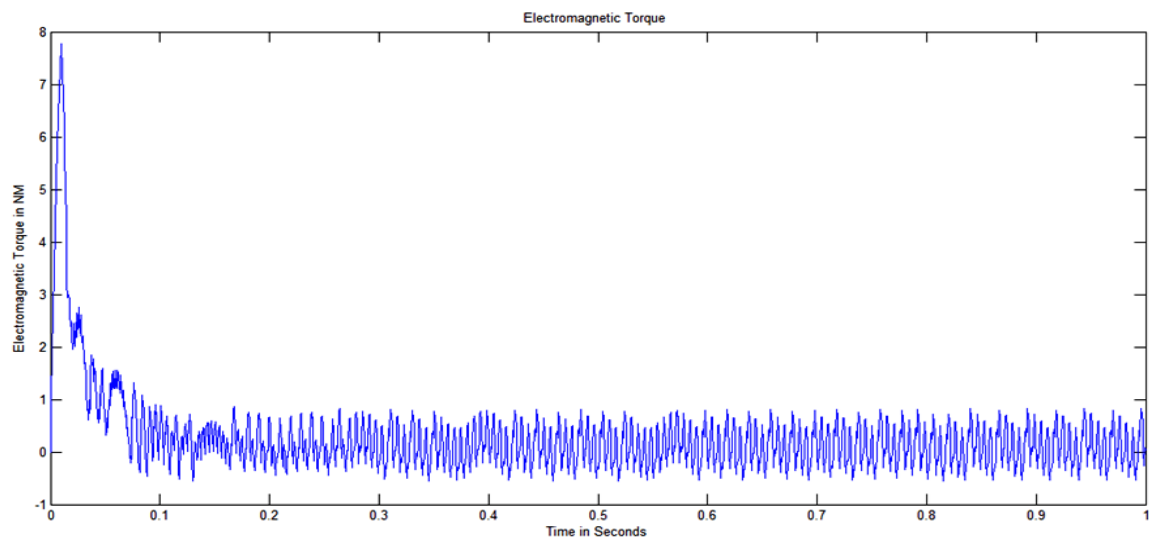

Figure 8. Torque of BLDC motor

6. CONCLUSION

This paper speaks to the structure and investigation of the proportional integral derivative controller and fractional order proportional integral derivative controller for the electronically commutated BLDC motor. In today's dynamic environment, where businesses prefer to invest capital in order to lower the cost of goods and increase the benefits to consumers, industrialization of controllers is a significant challenge. Accordingly, by taking a gander at these two controllers the presentation examination of FOPID is superior when contrasted with corresponding indispensable controller. FOPID controllers have technological advantages over integer-order counterparts, as illustrated, but the expense of manufacturing such controllers, as well as the cost-benefit analysis, are prohibitive. In such a case, it is suggested to look how to industrialized FOPID controllers considering financial factors. This is an open question that needs to be addressed in future research.

REFERENCES

- [1] J. Gouthaman, R. Bharathwajanprabhu, and A. Srikanth, "Automated urban drinking water supply control and Water theft identification system," Students' Technology Symposium, pp. 87-91, June, 2011, doi: 10.1109/TECHSYM.2011.5783807.
- [2] T. M. Jahns, "Torque production in permanent-magnet synchronous motor drives with rectangular current excitation," *IEEE Trans. Ind. Appl.*, vol. 20, no. 4, pp. 803-813, August, 1984.
- [3] R. Karthikeyan and S. Chenthur Pandian, "Generalized space vector PWM algorithm for minimizing THD in hybrid multilevel inverters," *International Review of Electrical Engineering*, vol. 6, no. 5, pp. 2094-2099, October, 2011.
- [4] R. Karthikeyan and S. Chendur Pandian, "An efficient multilevel inverter system for reducing THD with Space Vector Modulation," *International Journal of Computer Applications*, vol. 23, no. 2, pp. 0975-8887, 2011.
- [5] J. S. Ko, "Robust position control of BLDC motors using Integral-Proportional-Plus Fuzzy logic controller," *IEEE Trans. On IEEE*, vol. 24, no. 9, October, 2011, doi: 10.1109/41.238020.
- [6] R. Krishnan and A. J. Beutler, "Performance and design of an axial field permanent magnet synchronous motor servo drive," in *IEEE IAS Annual Meeting*, pp. 634-640, 1985.
- [7] P. Pillay and R. Krishnan, "Modeling analysis and simulation of a high performance, vector controlled, permanent magnet synchronous motor drive," *IEEE IAS Annu. Meeting*, April, 1987.
- [8] A. K. Singh and K. Kumar, "Modelling and Simulation of PID Controller Type PMSBLDC Motor," *Proceedings of National Seminar on Infrastructure Development Retrospect and prospects*, 2002, pp. 137-146.
- [9] H. K. Samitha Ransara and U. K. Madawala, "A Torque Ripple Compensation Technique for a Low-Cost Brushless DC Motor Drive," *IEEE Transactions on Industrial Electronics*, vol. 62, no. 10, pp. 6171-6182, Oct. 2015, doi: 10.1109/TIE.2015.2423664.
- [10] C. Xia, Y. Xiao, W. Chen and T. Shi, "Torque Ripple Reduction in Brushless DC Drives Based on Reference Current Optimization Using Integral Variable Structure Control," *IEEE Transactions on Industrial Electronics*, vol. 61, no. 2, pp. 738-752, Feb. 2014, doi: 10.1109/TIE.2013.2254093.
- [11] X. Huang, A. Goodman, C. Gerada, Y. Fang and Q. Lu, "A Single Sided Matrix Converter Drive for a Brushless DC Motor in Aerospace Applications," *IEEE Transactions on Industrial Electronics*, vol. 59, no. 9, pp. 3542-3552, Sept. 2012, doi: 10.1109/TIE.2011.2171171.
- [12] M. Brackley and C. Pollock, "Analysis and reduction of acoustic noise from a brushless DC drive," *IEEE Transactions on Industry Applications*, vol. 36, no. 3, pp. 772-777, May-June 2000, doi: 10.1109/28.845052.
- [13] K. Sundararaju and Nirmal Kumar, "Control analysis of STATCOM with enhanced methods for compensation of load variation," *A. European Journal of Scientific Research*, vol. 53, no. 4, pp. 590-597, May, 2002.
- [14] K. Nithiyananthan, and V. Ramachandran, "Versioning-based service-oriented model for multi-area power system online economic load dispatch," *Computers and Electrical Engineering*, vol. 39, no. 2, pp. 433-440, 2013, doi: 10.1016/j.compeleceng.2012.09.016.
- [15] S. Samson Raja, R. Sundar, A. Amutha, and K. Nithiyananthan, "Virtual Stability Estimator Model For Three Phase Power System Network," *Indonesian J. Elec. Eng. & Comp. Sci.*, vol. 4, no. 3, pp. 520-525, December, 2016, doi: 10.11591/ijeecs.v4.i3.pp520-525.
- [16] S. Thomas, K. Nithiyananthan, and A. Eski, "Investigations on transient behavior of an energy conservation chopper fed DC series motor subjected to a change in duty cycle," *Journal of Green Engineering*, vol. 9, no. 1, pp. 92-111, April, 2019.
- [17] G. Kasilingam, J. Pasupuleti, and K. Nithiyananthan, "Implementation and analysis of BBO algorithm for better damping of rotor oscillations of a synchronous machine," *Advances in Intelligent Systems and Computing*, vol. 672, pp. 73-85, January, 2018, doi: 10.1007/978-981-10-7512-4_8.
- [18] K. Nithiyananthan, and Pransu Jain, "Logixpro Based Scada Simulation Model For Packaging System In Dry Ice Plant," *International Journal of Electrical and Computer Engineering*, vol. 5, no. 2, pp. 443-453, June, 2015, doi: 10.11591/ijece.v5i3.
- [19] M. Yi Wen, and Ching-Chang Wong Han-Chen Wu, "Speed Control of BLDC Motors Using Hall Effect Sensors Based on DSP," *IEEE*, vol. 2, pp. 7-9, July, 2016, doi: 10.1109/ICSSE.2016.7551633.
- [20] A. Padalkar, "Speed and Position Control of BLDC Motor using Internal Hall Sensors and Hardware Design," *International Conference on Information Processin*, pp. 16-19, 2015.

- [21] A. Kumar, U. Sharma and B. Singh, "Single Switch Boost-Flyback PFC Converter for BLDC Motor Drive used in Ceiling Fan," *IEEE International Conference on Computing, Power and Communication Technologies (GUCON)*, pp. 534-539, October 2020.
- [22] B. Prakash Adangi Kiran Kumar Vadlamudi, "High Response and Variable Speed Operated BLDC Drive with Current Control Technique," *2015 International Conference on Electrical, Electronics, Signals, Communication and Optimization (EESCO)*, September, 2015, doi: 10.1109/EESCO.2015.7253673.
- [23] A. bin Jidin, A. R. bin Abdullah, and M. N. bin Othman Norhazilina Binti Bahari, "Modeling and Simulation of Torque Hysteresis Controller for Brushless DC Motor Drives," *IEEE Symposium on Industrial Electronics and Applications (ISIEA2012, Bandung, Indonesia)*, pp. 23-26, 2011.
- [24] H. Chen and H. Huang, "Design of buck-type current source inverter fed brushless DC motor drive and its application to position sensorless control with square-wave current," *IET Electric Power Applications*, vol. 7, pp. 416-426, May, 2013, doi: 10.1049/iet-epa.2013.0002.
- [25] S. Jianwen *et al.*, "A novel microcontroller-based sensorless brushless DC (BLDC) motor drive for automotive fuel pumps," *IEEE Transactions on Industry Applications*, vol. 39, pp. 1734-1740, December, 2003, doi: 10.1109/TIA.2003.818973.

BIOGRAPHIES OF AUTHORS



Dr. Issa Etier is an Associate Prof. in the Electrical Eng. Dept at Hashemite University. He joined the Electrical Eng. Dept in 2005. He received his Master's and Ph. D. Degrees in Electrical Eng. in Institute of Energy and Automation Technology from T. U. Berlin in 1996 and 2005, respectively. Chair and establishment of the Department of Energy Engineering at the Zarqa University. His research interests include Renewable Energy systems, Energy conversion and Photovoltaic Systems.



Ancil Manon Mary A. received the B.Tech. degree in Electrical and Electronics Engineering from the Karunya University, Coimbatore, India in 2009, the M.Tech. degree in Applied Electronics from Karunya University, Coimbatore, India, in 2011. She is currently working as Assistant Professor in department of Electrical Engineering at Karpagam College of Engineering, Coimbatore, India. Her research interests are multilevel inverters and pulse width modulation techniques for drives.



Prof. Dr. Nithiyannathan Kannan is currently working as a Professor in the Department of Electrical Engineering, King Abdulaziz University, Rabigh, Saudi Arabia. He has 21 years of teaching/research experience. He completed his PhD in Power System Engineering from the College of Engineering, Guindy Campus, Anna University, India in 2004. He is an active member of IET (UK) and he received Chartered Engineer title in 2016 from Engineering Council, UK. His areas of interest are computer applications to power system engineering, modelling of modern power systems, renewable energy, smart grid and micro grid.