High Power Factor Power Design

Zhang Jing-yi

The School of Information Engineering Wuhan University of Technology,
Wuhan, Hubei, China 430070
e-mail: 313823836@qq.com

Abstract

The PFC circuit takes UCC28019 made by TI Company as the core of system control, realize the power factor correction circuit functions, and the circuit power factor can be measured. Through a variety of detection circuit, with the support SCM control. And 30V~36V output voltage regulator can be set; with over-current protection circuits function, and be able to automatically back. Output current, voltage, and little significant value are displayed by display modules.

Keywords: PFC; Voltage adjust; High-efficiency

Copyright © 2013 Universitas Ahmad Dahlan. All rights reserved.

1. Introduction

From the 1960s, with the development of power electronics technology, there were a large number of power electronic devices emerged in the industrial and life domestic. For instant, when the rectifier device and the electronic rectifier connected to the grid, the current of the grid will produce a non-sinusoidal distortion, lead up to the voltage of the grid producing a non-sinusoidal distortion and a higher harmonic which may affect the normal operation of other electrical equipment, communications, it may also affect the safety of operation of the power generation equipment if it is serious. So, how to improve the input current waveform and power factor of power electronic devices has become an important factor which will be considered by power electronic product development [1]. The traditional correction of power factor technology is the passive PFC, linking a resonant filter in the AC side or a passive filtering network consist of filtering inductance and filtering capacitance behind the rectifier bridge, make the input current harmonic content satisfy harmonic limit requirements, so as to improve the power factor. The passive PFC has some advantages like simple structure, high reliability, low cost, small EMI etc. But the required low frequency filtering inductance and filtering capacitance value is big, so may cause their large size, circuit heavy and hard to get good power factor. In order to overcome this shortcomings, this paper introduces a design of high-power-factor power supply based on active PFC, the use of active PFC realizes the power factor correction of circuit, make the electricity equipment hanging on the side of the grid electricity into a closely pure impedance load, not only can restrain power grid side harmonic current, improve the network side power factor, reduce the high harmonics noise and pollution, improve the quality of power grid, also make the power electromagnetic compatibility ability strengthened [2].

2. Schematic Designs

The system uses the technique of active PFC circuit to realize the power factor correction, namely adding a power conversion circuit between the load of the rectifier circuit and output capacitance, correct the input current to the same phase of the sine wave with the input voltage. Application of high speed PIC18F66J10 PIC micro controller to process the sampling signal will be able to accomplish the function such as voltage setting. System uses UCC28019 as the main control chip of the PFC circuit. UCC28019 is a controller with 8 pin and continuous current mode (CCM), with minimal harmonic distortion can get close to the unit power factor level, very suitable for the PFC application in the design. Plus control circuit and some auxiliary circuit, can get the overall scheme of the system design, as shown in Figure 1.

microcomputer software control; voltage regulator will have a better performance with two aspects.

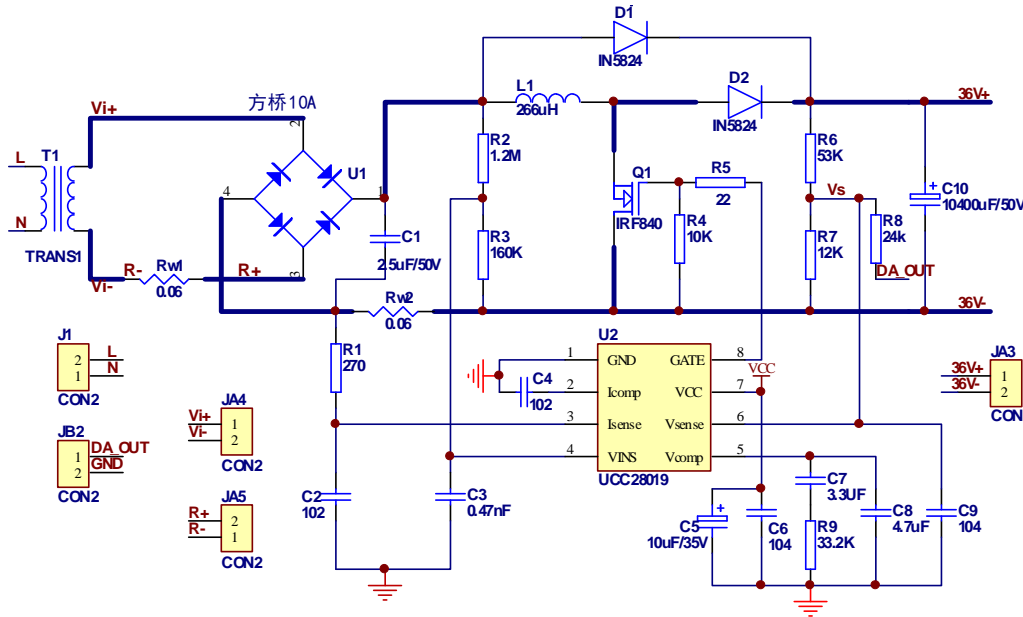

Figure 2. PFC control circuit

The sampling resistance R_{W2} uses the constantan wire which with a little temperature excursion and a high precision. All the resistance of the current of all the detection circuit in this system will use constantan wire, in order to ensure the accuracy of the sampling current in the system [5]. But when the current value is too large, the constantan wire will account for a certain pressure drop, the pressure drop will influence the accuracy of the output voltage value, so in the use of voltage compensation in the program design, to offset the impact of the constantan wire [6].

In this design the flowing current can reach more than 7A when the switch tube conduction, so choose the field-effect tube 75NF75 as PFC circuit switch tube with fast switching speed, high input impedance, small driving power, small switching loss and the maximum current for 75A.

Circuit inductance calculation can be expressed as follows:

$$I_{IN-RMS(max)} = \frac{P_{out(max)}}{\eta V_{IN(min)} Pf} = \frac{100w}{0.92 \times 18v \times 0.99} = 6.10A \quad (1)$$

$$I_{IN-PEAK(max)} = \sqrt{2} I_{IN-RMS(max)} = \sqrt{2} \times 6.10A = 8.625A \quad (2)$$

$$I_{RIPPLE} = \Delta I_{RIPPLE} \times I_{IN-PEAK(max)} = 1.725A \quad (3)$$

$$L_{BST(min)} \geq \frac{V_{out} D(1-D)}{f_{sw(tp)} I} = \frac{36 \times 0.5 \times 0.5}{65000 \times 1.725} = 80.26 \mu H \quad (4)$$

Current loop sampling resistor (constantan wire) can be calculated as follows:

$$R_{SENSE} = \frac{V_{soc}}{I_{L-PEAK(max)} \times 1.25} = \frac{0.66}{9.49 \times 1.25} = 0.0556\Omega \quad (5)$$

3.2. Detection and Protection Circuit Design

The function of the circuit is acquiring each part of the electrical signal in the circuit and the over current protection of the circuit [7].

Detection circuit part consists of voltage detection circuit, current detection circuit, the load intelligent detection circuit and phase detection circuit. In order to realize the control strategy, the system tests four individual: input rectifier voltage, input inductance current, output voltage and output current.

3.2.1. The Phase Detection Circuit

This design calculate the power factor value by means of the difference of phase of input voltage and current, so, you need a circuit to acquire the phase relationship between voltage and current, we acquire the phase difference through the phase detection circuit [8]. Phase detection circuit including current phase detection and voltage phase detection, detection circuit as shown in Figure 3 and Figure 4.

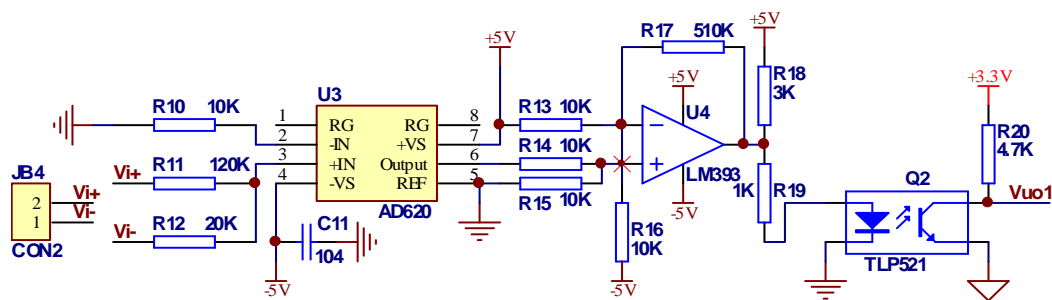

Figure 3. Voltage phase detection circuit

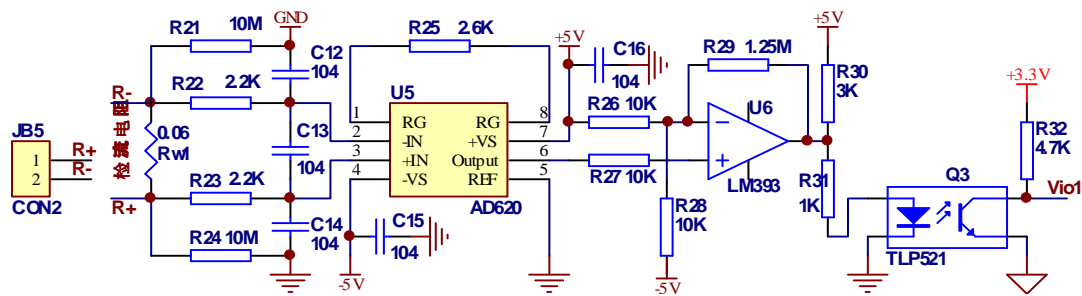

Figure 4. Current phase detection circuit

3.2.2. Intelligent Load Detection Circuit

The system uses intelligent load detection circuit with over-current protection, after debugging, the system can automatically return to normal. Circuit diagram as shown in Figure 5 shows, the current only go through the relay contact when the system good running, the relay controlled disconnect when add heavy duty happened flow [9]. If the load is adjusted for big resistance form, according to the series partial pressure principle, the difference pressure of diode and 2k resistance ports decreases, and use the software to determine whether it is in the safe load range. When the load reduce, microcomputer control relay to be closed, make the circuit returned to normal.

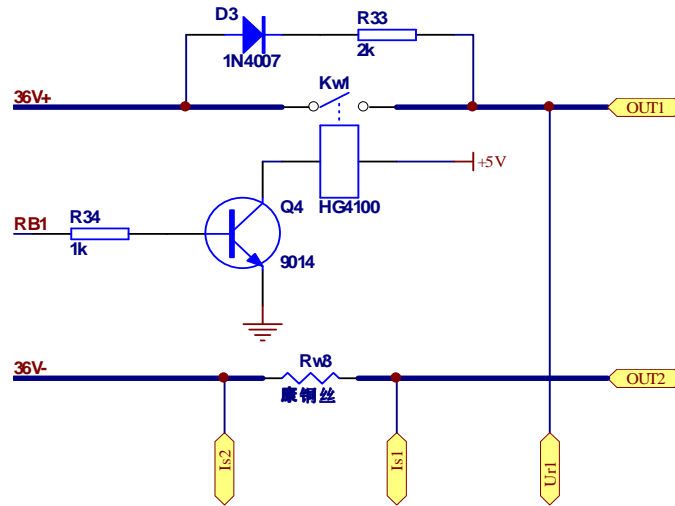

Figure 5. Intelligent load detection circuit

3.2.3. Voltage Sampling Circuit

Output voltage detection and current detection adopts high precision instrument amplifier AD620 to realize, the circuit is shown in Figure 6 and Figure 7. By changing the compensation resistance R_G between 1 and 8 feet in AD620 chip to change the magnification G in AD620 chip. The relationship between them is $G = \frac{49.4k}{R_G} + 1$

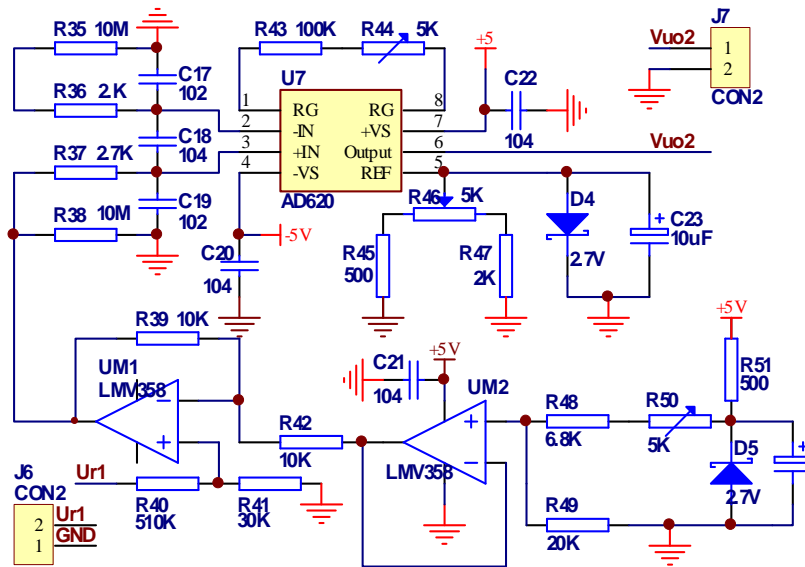

Figure 6. Voltage sampling circuit

From the above discussion, use the constantan wire as sampling resistance of current detection circuit, the constantan wire value and the detected voltage value is small, therefore, the signal must be accurately amplified by AD620 before sending to the microcomputer to calculate processing. The current detection circuit is shown in Figure 7.

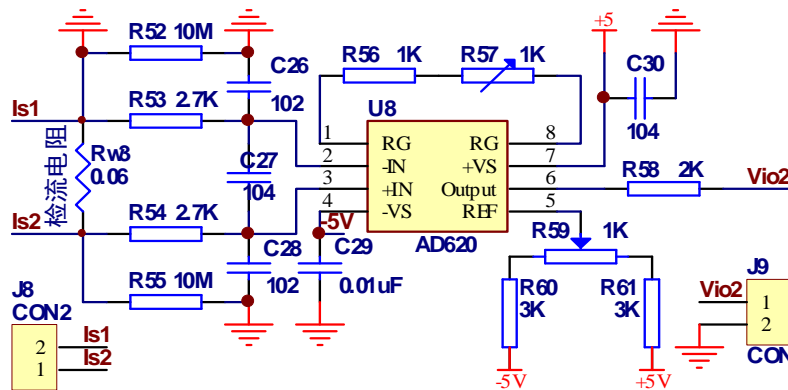

Figure 7. Current detection circuit

3.3. Microcomputer control circuit and A/D conversion circuit

As a part of the control circuit in this design, the microcomputer is the system controller as well as to realize the function of data processing and operation. The Design select the high speed PIC18F66J10 microcontroller, there are A/D conversion module and other analog and digital circuit integrated on the chip. PIC18F66J10 microcontroller receives the voltage from the detection circuit and analog current signals, converted to digital signals then sending to digital display module to display, at the same time, send the signal to D/A converter by SPI interface after process by the software, then it will output a analog control signal, send back to the PFC circuit after going through a resistor network, constitute a double feedback control [10].

The output signal of microcomputer can realize the control to the circuit only before passing a D/A conversion circuit, the design uses MCP4922 with a low power consumption and a D/A converter to realize the digital-to-analog conversion of the signal. The circuit is shown in Figure 8.

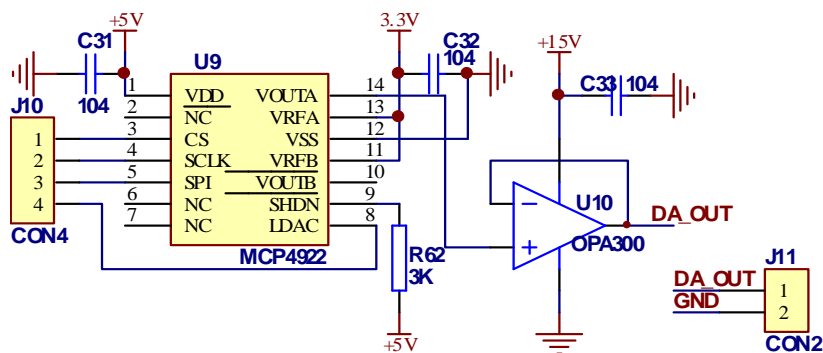

Figure 8. MCP4922 D/A conversion circuit

The analog signal of D/A module is not directly used to control the output voltage signal, but rather to achieve the purpose of control the value of the output voltage by combining a VS signal from the UCC28019 through a feedback resistance network, as shown in Figure 9.

As follows:

$$\frac{V_{OUT} - 5}{53} = \frac{5 - V_{SET}}{24} + \frac{5}{12} \tag{6}$$

$$\begin{aligned} V_{OUT} &= \frac{5 \times 53}{24} - \frac{53}{24} V_{SET} + \frac{5 \times 53}{12} + 5 \\ &= 38.125 - 2.2V_{SET} \end{aligned} \tag{7}$$

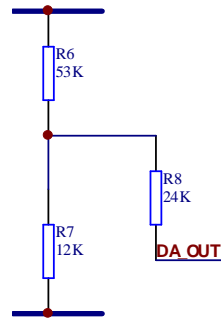

Figure 9. Feedback resistor network

4. Software Design

The tasks of software system are as follows: current sampling (over-current protection), voltage sampling, current/voltage phase difference detection, power factor operation, man-machine interface communication and voltage control PID arithmetic [11]. The System uses time-sharing multitasking way to coordinate the task. The CPU time is divided into a small time slice to 1 ms as a unit, each time slice assign a task, (already to ensure that each task period of time less than 1 ms), every ten ms as a cycle. Voltage and current phase detection through the interrupt to achieve, voltage, and current input to the CPU external interrupt port, acquisition two interrupt time to determine the phase difference power factor [12].

5. Results and Performance Analysis

As shown in Table 1, the maximum output voltage is 36.10V in this high power factor power design, the minimum output voltage is 35.96, the maximum absolute value of the error is 0.1V, the maximum error is 0.27%, less than 2%, and the precision is very high.

Table1 Voltage regulation test table

Vi(V)	Io(A)			
	0.5	1	1.5	2
15	36.04	36.00	35.97	35.96
16	36.07	36.03	35.98	35.97
17	36.06	36.04	35.99	35.97
18	36.07	36.05	36.02	35.99
19	36.10	36.08	36.02	35.98

When the U2 transform from 15V to 22V, the voltage regulation $S_u(I_o=2A)$ is

$$S_u = \frac{|U_{21} - U_{15}|}{U_{15}} \times 100\%$$

When the output current value is up to 2.5A, the over-current protection of output current will start up automatic.

Observing the distortion factor of the testing waveform with an oscilloscope when the vice side current of the transformer is sine wave is 2.2%. Observing the waveform of circuit current and voltage, the oscilloscope displays the current waveform leading voltage 260 μ s, calculating the power factor value is about 99.7%, is very close to the showed value of power factor detection 99.6%.

In addition, we have done a power factor measurement display module, current and voltage sampling and display circuit can achieve a high precision and accuracy, and the measurement error of current and voltage and power factor is less than 2%[13]. In the

transformer's vice edge is 18V AC, we adjust the value of the load, which makes the current for different values, to verify the accuracy of voltage display value and the actual value, is recorded as Table 2.

Table 2. The error of Output current and voltage

Load current 0.5A	Measured value U0	30.00	31.00	32.00	33.00	34.00	35.00	36.00
	Actual value U1	30.11	31.08	32.13	32.89	34.12	35.09	36.12
	Error	0.37%	0.25%	0.41%	0.33%	0.35%	0.26%	0.33%
Load current 1A	Measured value U2	30.00	31.00	32.00	33.00	34.00	35.00	36.00
	Actual value U3	30.03	31.06	31.95	33.10	34.17	35.10	36.09
	Error	0.1%	0.19%	0.16%	0.3%	0.2%	0.27%	0.25%
Load current 1.5A	Measured value U4	30.00	31.00	32.00	33.00	34.00	35.00	36.00
	Actual value U5	30.03	31.05	32.09	33.06	34.10	35.12	36.08
	Error	0.1%	0.18%	0.28%	0.2%	0.24%	0.34%	0.25%
Load current 2.0A	Measured value U6	30.00	31.00	32.00	33.00	34.00	35.00	36.00
	Actual value U7	30.01	31.07	32.05	33.11	33.92	35.01	36.05
	Error	0%	0.22%	0.15%	0.3%	0.236%	0%	0.14%

6. Conclusion

As it is showed in the test data, the design has been good to complete the expected meter goal, the value of power factor reaches as high as 99%, and the stability is good. But there are also some deficiencies, such as there is clutter in output, and there is a large error between the output voltage set value and actual output value, etc., these problems need to improve in the future study [14].

References

- [1] Dewan SB, Straughen A. *Power Semiconductor Circuits*. John Wiley and Sons, New York. 1975.
- [2] Hart DW. *Introduction to Power Electronics*. Prentice-Hall. 1994.
- [3] Mohan N. *Power Electronics*. 3rd Edition, Wiley. 2003.
- [4] Robert WE, Dragan M. *Fundamentals of Power Electronics*. Second Edition, Springer, ISBN 0-7923-7270-0.
- [5] Shepherd W, et al. *Power Electronics and motor control*. Cambridge University Press. 2nd Edition 1995.
- [6] Kantonidou MM. Engineering Education and Engineering Practice: A Student Teacher Perspective // *Electronics and Electrical Engineering*. 2010; 6: 167-170.
- [7] Bagdanavicius N, Andriukaitis D, et al. Possibilities of Electronics Engineering Studies in University and College. *Electronics and Electrical Engineering*. 2011; 7: 32-36.
- [8] Prikler L, Høidalen HK. ATPDraw Users' Manual. *SINTEF Energy Research*. 2002.
- [9] PD Tan and RD Middlebrook. "A unified model for current-programmed converters". *IEEE Trans. Power Electron*. 1995; 10(4): 397-408.
- [10] RA Cheville, A McGovern, and KS Bull. "The light applications in science and engineering research collaborative undergraduate laboratory for teaching (LASER CULT)-relevant experiential learning in photonics". *IEEE Trans. Educ*. 2005; 48(2): 254-263.
- [11] R Holloway and G Eirea. "Model current-mode control with ease and accuracy". *Power Electron. Technol*. 2008: 22–25.
- [12] Yang Han. A pedagogical approach for modeling and simulation of switching mode DC-DC converters for power electronics course. *TELKOMNIKA*. 2012; 10(6): 1319-1326.
- [13] Ping Li*, Tao Liang, Yangchun Cheng, Liang Zhao. High frequency characteristic of rogowski coil. *TELKOMNIKA*. 2012; 10(8): 2209-2214.
- [14] A Mantri, S Dutt, JP Gupta, and M Chitkara. "Design and evaluation of a PBL-based course in analog electronics". *IEEE Trans. Educ*. 2008; 51(4): 432-438.