

Modeling Technology in Traveling-Wave Fault Location

Tang Jinrui*, Yin Xianggen, Zhang Zhe

State Key Laboratory of Advanced Electromagnetic Engineering and Technology, Huazhong University of Science and Technology, Wuhan 430074, China

*Corresponding author, e-mail: tangjinrui@hust.edu.cn

Abstract

Theoretical research and equipment development of traveling-wave fault location seriously depend on digital simulation. Meanwhile, the fault-generated transient traveling wave must be transferred through transmission line, mutual inductor and secondary circuit before it is used. So this paper would mainly analyze and summarize the modeling technology of transmission line and mutual inductor on the basis of the research achievement. Firstly several models of transmission line (multiple Π or T line model, Bergeron line model and frequency-dependent line model) are compared in this paper with analysis of wave-front characteristics and characteristic frequency of traveling wave. Then modeling methods of current transformer, potential transformer, capacitive voltage transformer, special traveling-wave sensor and secondary cable are given. Finally, based on the difficult and latest research achievements, the future trend of modeling technology in traveling-wave fault location is prospected.

Keywords: traveling wave, fault location, transmission line model, mutual inductor model

Copyright © 2013 Universitas Ahmad Dahlan. All rights reserved.

1. Introduction

Fault location based on the fault-generated traveling wave has the advantages of more accurate positioning result and less influence by saturation characteristic of current transformer, fault resistance, fault type and the operating mode of system compared with impedance-based fault location. It has already become a focus in recent years and has been widely applied into transmission network [1-2]. Actually, all the waveform in instant beginning of the fault course, fault transient state and fault steady state can be regarded as traveling wave [3]. Based on it, traveling-wave-based fault-location algorithm can be grouped into the following main categories: 1) algorithms based on wave-front identification (single-ended algorithm, two-ended algorithm and network-based algorithm); 2) algorithms based on characteristic frequency of traveling wave [4].

Compared with its wide application, test technology of traveling-wave fault location falls behind obviously. Early verification of traveling-wave fault-location technology is difficult to operate directly in power grid, while different fault types can't appear in a short time. At the same time, normal dynamic physical simulation can't meet the test demand because of the limitation of transmission line model and other factors [5]. Therefore, theoretical research and equipment development of traveling-wave fault location seriously depend on digital simulation [6]. Meanwhile, frequency of the transient signals used in both methods mentioned above can be greater than 10 kHz and the fault-generated transient traveling wave must be transferred through transmission line, mutual inductor and secondary circuit before it is used.

Most electromagnetic transient simulation softwares are based on the principles outlined in the classic 1969 paper by Hermann Dommel (ATP-EMTP, EMTP-RV, MicroTran, PSCAD/EMTDC and etc.) [7]. Thus this paper would analyze and summarize the modeling technology of transmission line, mutual inductor and secondary circuit based on the latest research achievements, meanwhile, take the PSCAD/EMTDC as an example, it would propose the key points of modeling technology in traveling-wave fault location.

2. Transmission Line Model

The following transmission line models have been provided in simulation softwares: multiple Π or T line model, Bergeron line model and frequency-dependent line model.

2.1. Multiple Π or T Line Model

The principle of distributed parameter circuit should be used to analyze the traveling wave propagation in transmission line. As shown in Figure 1, multiple Π or T line model is used and a short circuit fault happens at the end.

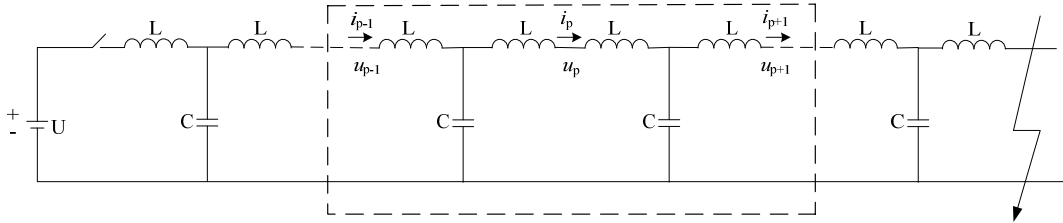

Figure 1. Multiple Π or T Line Model

Assume equivalent inductance of the system is zero, from the analysis in [5], multiple Π line model and multiple T line model have the same difference equation, the voltage at the p^{th} chain of the line is as follows:

$$u_p(t) = U \left(1 - \frac{p}{n} - \frac{1}{n} \sum_{k=1}^n \cot \frac{k\pi}{2n} \sin \frac{kp\pi}{n} \cos \omega_k t \right) \tag{1}$$

where: $\omega_k = \frac{2}{\sqrt{LC}} \sin \frac{k\pi}{2n}$.

The Equation (1) shows that: 1) oscillation would happen in the chain network; 2) there exists n oscillating angular frequencies which equals the number of the chains. In digital simulation or dynamic physical simulation, number of the chains can't be infinite. Then it can't simulate the traveling wave front accurately and can't meet the test demand of the fault location algorithm based on wave-front identification as shown in Figure 2.

When n approaches to infinity, Equation (2) can be derived and it is the basis of characteristic-frequency fault-location algorithm.

$$f_0 = \left[\lim_{n \rightarrow \infty} \left(\frac{2}{\sqrt{LC}} \sin \frac{k\pi}{2n} \right) \right] / 2\pi = \frac{k}{2 * l * \sqrt{LC}} \tag{2}$$

Thus simulation results of multiple Π or T line model can't describe the actual wave-front characteristics and characteristic frequency of traveling wave because of the limited number of the chains.

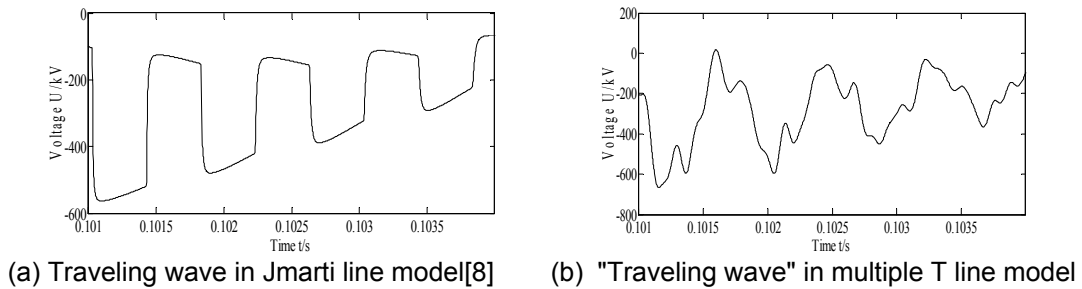

Figure 2. Comparison of Simulation Results between Jmarti and Multiple T Line Model

2.2. Bergeron Line Model

Assume parameters of the conductor are independent of frequency, Bergeron model can be used for transient calculation for lossless transmission line as shown in Figure 3. When line loss is taken into account, the total system resistance can be equivalent to lumped parameter ($1/2$ in the middle of the line and $1/4$ at each end).

Actually parameters are affected by frequency due to skin effect and it is the main reason of traveling-wave dispersion. The dispersion will be more obvious in zero-mode wave. For a three-phase transmission line, comparison of the simulation results between Bergeron model and Jmarti model in which dispersion is considered is shown in Figure 4 when a single phase-to-ground fault happens.

From the analysis mentioned above, Bergeron line model can't meet the test demand of the fault location algorithm based on wave-front identification because it ignores the traveling-wave dispersion. But traveling-wave propagation would be simulated accurately when the skin effect can be omitted. Because the frequency of the component used in fault location algorithm based on characteristic frequency is usually low and the algorithm doesn't need to recognize wave fronts [4], the dispersion has little affection on this algorithm. Thus Bergeron can be used to test the fault location algorithm based on characteristic frequency to some extent.

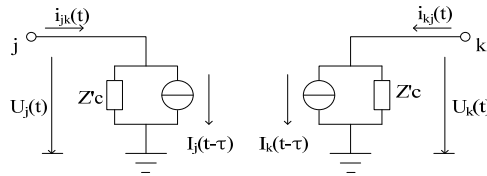
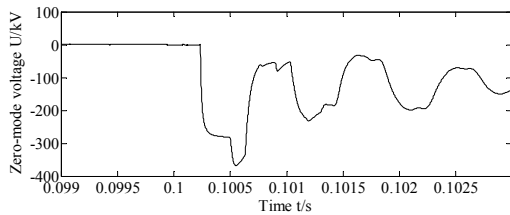
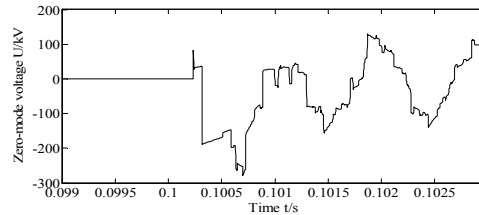

Figure 3. Bergeron Line Model



(a) Traveling wave in Jmarti line model



(b) Traveling wave in Bergeron line model

Figure 4. Comparison of Simulation Results between Jmarti and Bergeron Line Model

2.3. Frequency-dependent Line Model

When parameters of the conductor vary with frequency, the traveling wave propagation must be calculated in frequency domain while the electromagnetic transient calculation is easy to carry out in time domain. To solve this problem, one method is to treat the characteristic impedance and propagation coefficient with approximation by rational function based on Bode diagram [8].

The current on both sides of transmission line $k-m$ is as follows:

$$\begin{cases} I_k = \frac{U_k}{Z_c} + I_{kh} \\ I_m = \frac{U_m}{Z_c} + I_{mh} \\ I_{kh} = -\frac{1}{Z_c} (U_m + Z_c I_m) A = -\frac{2F_m}{Z_c} A \\ I_{mh} = -\frac{1}{Z_c} (U_k + Z_c I_k) A = -\frac{2F_k}{Z_c} A \end{cases} \quad (3)$$

where: I_k, U_k – current and voltage on the k side; I_m, U_m – current and voltage on the m side; Z_c – characteristic impedance; A – propagation coefficient, $A = e^{-\sqrt{ZY}l}$, l – length of the line $k-m$.

The line model proposed in [8] is the known Jmarti line model. In the paper two rational functions are utilized to simulate $Z_c(\omega)$ and $A(\omega)$. The principle of this method is to use analog filtering technology to identify frequency-dependent parameters in fact. Based on this method, Jmarti line model still has the basic form as same as Bergeron line model and thus it is easy to be realized in the common electromagnetic transient program such as ATP-EMTP, PSCAD/EMTDC and etc.

Besides the "Frequency dependent (Mode)" model which is Jmarti line model, PSCAD/EMTDC also provides "The Frequency Dependent (Phase)" model. It transcends the frequency dependent transformation matrix problem by direct formulation in the phase domain. Based on these models, PSCAD/EMTDC gives out the corresponding models of overhead lines and cables.

Because the parameters calculation of cables are complicated, early versions of PSCAD/EMTDC don't provide multi-core cable model. Models of three-core cable, four-core cable and eight-core cable begin to appear in PSCAD X4 version.

At present, many researches haven been done to develop more reliable and more accurate line model [9], but Jmarti line model is still the common model used in traveling-wave fault location.

3. Mutual Inductor Model

Besides the propagation in transmission line, fault-generated transient voltage and current signal also need to be transferred through mutual inductor before it is used for fault location. At present mutual inductors using in traveling-wave fault location can be grouped into the following categories: (1) current transformer (CT) [10] or potential transformer (PT) [11]; (2) capacitive voltage transformer (CVT) [12]; (3) special traveling-wave sensor [1, 13].

Many literatures have studied modeling method of CT, PT and CVT, but most of them are focused on accurate transient simulation under 10kHz to test relaying protection algorithm and accurate simulation to simulate saturation characteristics of current transformer [14-16].

3.1. Modeling Method of CT and PT

PSCAD/EMTDC provides two models of CT (Jiles-Atherton-based CT model and Lucas-based CT model) and a single model of PT. These models are all built to study relaying protection algorithm and they are not suitable to be applied in traveling-wave fault location.

At present, modeling methods of CT and PT in the frequency range of traveling wave are mainly divided into two classes: (a) distributed model based on the internal structure; (b) transfer function model based on frequency response parameters.

3.1.1. Distributed Model based on the Internal Structure

Through the theoretical analysis and experimental test, literature [17] regarded CT or PT as a special transformer and divided the wave process into electrostatic induction process, free oscillation process and electromagnetic induction process. Thus distributed model of CT or PT can be built based on the distributed model of single-phase transformer and the theoretical analysis of wave process in the coil. The distributed model is shown in Figure 5. For this model, Identification of parameters is the difficulty while the researchers should be very clear about the internal structure of CT or PT and do a lot of experimental studies [18-19].

3.1.2. Transfer Function Model based on Frequency Response Parameters

To build transfer function model of CT or PT, firstly the wide-band transfer characteristics and scattering parameters of the transformers are measured, then the measured data is fitted with rational approximation formulas to obtain transfer function, finally the model of CT or PT can be built based on the circuit model synthesized by the transfer function [20-21].

The rational transfer function of CT or PT can be written as follows:

$$f(s) = \sum_{n=1}^N \frac{c_n}{s-a_n} + d \quad (4)$$

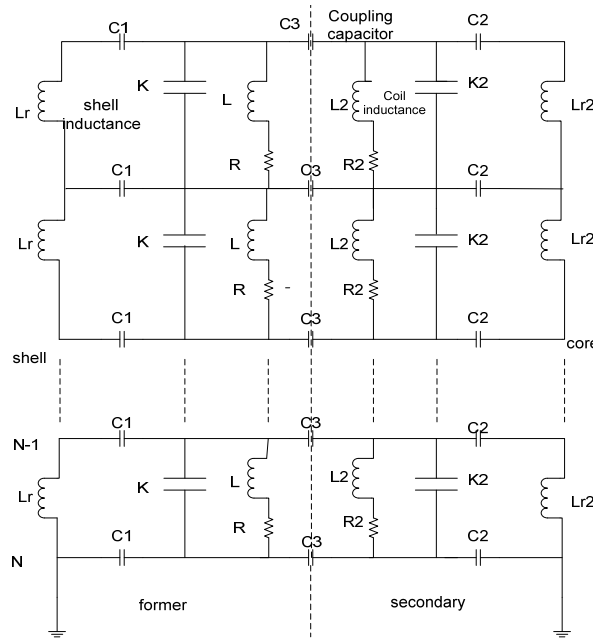

Figure 5. Distributed Model of CT or PT based on Internal Stricter

The residues c_n and poles a_n are either real quantities or complex conjugate pairs, while d is real. N is the total number of poles. Assume there are K complex conjugate pole pairs and $N-2K$ real poles in left half plane, then formula (4) is modified as:

$$f(s) = \sum_{n=1}^K f_{1n}(s) + \sum_{n=1}^K f_{2n}(s) + \sum_{n=2K+1}^N f_{3n}(s) + f_4(s) \tag{5}$$

Where:

$$f_{1n}(s) = \frac{2c_m p_m - 2p_{in} c_{in}}{s^2 + 2p_m s + p_m^2 + p_{in}^2} \tag{6}$$

$$f_{2n}(s) = \frac{2c_m s}{s^2 + 2p_m s + p_m^2 + p_{in}^2} \tag{7}$$

$$f_{3n}(s) = \frac{c_n}{s - a_n} \tag{8}$$

$$f_{4n}(s) = d \tag{9}$$

$$\begin{cases} a_{2n-1} = -p_m + j p_{in} \\ a_{2n} = -p_m - j p_{in} \end{cases} \quad (n=1, \dots, K) \tag{10}$$

$$\begin{cases} c_{2n-1} = c_m + j c_{in} \\ c_{2n} = c_m - j c_{in} \end{cases} \quad (n=1, \dots, K) \tag{11}$$

According to the transfer function of capacitance and inductance, (6-9) can be realized using the three circuits shown in Figure 6.

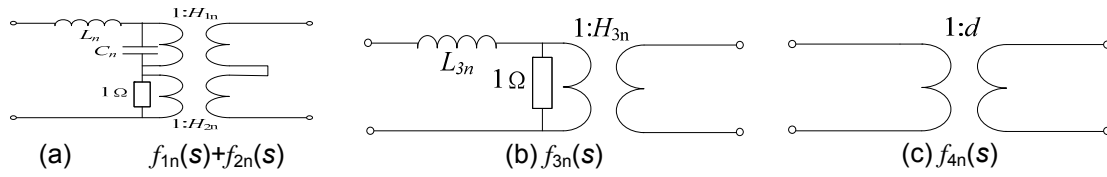

Figure 6. Equivalent Model for Transfer Function

In Figure 6, $H_{1n} = 2 \frac{c_m p_m - p_{in} c_{in}}{p_m^2 + c_{in}^2}$, $H_{2n} = \frac{c_m}{p_m}$, $L_n = \frac{1}{2 p_m}$, $C_n = \frac{2 p_m}{p_m^2 + p_{in}^2}$, $H_{3n} = -\frac{c_n}{a_n}$, $L_{3n} = -\frac{1}{a_n}$.

Based on the analysis mentioned above, transfer function model for CT or PT is given in Figure 7.

Modeling method based on transfer function only needs function-generator and numerical memory oscilloscope to get the wide-band transfer characteristics while the distributed model needs to know internal structure and do a lot of experimental studies.

3.2. Modeling Method of CVT

CVT, mainly including capacitive divider, intermediate voltage inductor, intermediate voltage transformer (SDT), damping arrangement and the burden [14], is widely used in the power systems whose voltage level is 220kv and above.

The equivalent circuit of CVT is shown in Figure 8. Literature [15] presented that transient response of CVT would have several resonant modes when considering the effect of stray capacitance, namely the frequency response of CVT presented obvious band-pass and band-stop characteristics. Without regard to the stray capacitance between the SDT primary winding and secondary winding, literature [15] analyzed the transient response characteristics of CVT.

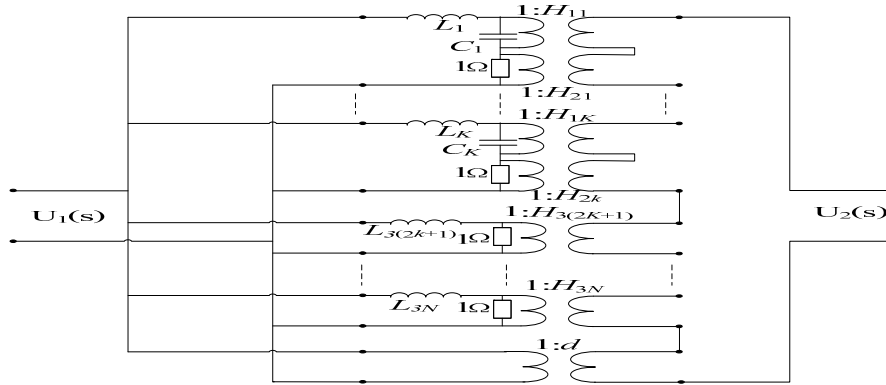

Figure 7. Transfer Function Model based on Frequency Response Parameters

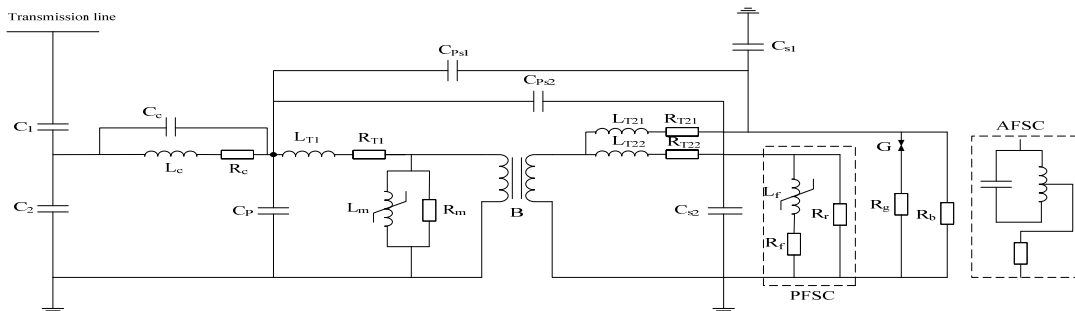

Figure 8. Equivalent Circuit of CVT

Literature [12] proposed that the stray capacitance C_{ps} between the SDT primary winding and secondary winding would affect the high-frequency response characteristic of CVT (above 10kHz), namely C_{ps} would lead to obvious resonance in the band range of traveling wave. Thus the traveling-wave fault location must take C_{ps} into account.

The single model of CVT provided by PSCAD/EMTDC doesn't contain the stray capacitance C_p of the SDT primary winding and the stray capacitance C_{ps} . According to the analyses of literatures [12, 15], they would affect the high-frequency response characteristic of CVT obviously, so the provided CVT model in PSCAD/EMTDC can't meet the test demand of traveling-wave fault location.

3.3. Modeling Method of Special Traveling-wave Sensor

Traveling-wave sensors are usually installed around CVT or other capacitive equipments [1, 13, 22] in the substation and always have good transient response effect. But due to different structures, they are hard to be modeled based on the internal structure. So the modeling method based on frequency response parameters is feasible in this situation.

4. Secondary Cable Model and Burden Model

Generally speaking, only transferred through secondary cable first can the signals obtained from mutual inductors be finally used for fault location equipment. Traveling-wave propagation in secondary cable is the same as that in transmission line and it would cause wave-front free oscillation [23].

The burden would affect the frequency response of CVT or other mutual inductors [14], so it should also be considered in simulation.

5. Summary and Prospect

At present, 1) Jmarti line model is the most widely used model in traveling-wave fault location, the influence of its error on wave front and how to build a more effective line model need further research; 2) modeling method of mutual inductor is the key part in traveling-wave digital simulation, and the CT model, PT model, CVT model provided by PSCAD/EMTDC can't meet the test demand; 3) distributed characteristic of the windings should be taken into account in CT and PT modeling; 4) stray capacitance should be considered in CVT modeling; 5) the influence of secondary cable on the signal used for fault location can't be ignored; 6) modeling technology is very useful for the study of traveling-wave extraction method and traveling-wave fault-location algorithm; 7) development of smart substation, especially the application of electronic instrument transformer, would bring new challenges to traveling-wave fault location, the corresponding modeling technology should be further studied.

Acknowledgments

This research was supported by the National Natural Science Foundation of China (No. 51177058).

References

- [1] Lee H, Mousa AM. GPS travelling wave fault locator system s: investigation into the anomalous measurements related to lightning strikes. *IEEE Transactions on Power Delivery*. 1996; 11(3): 1214-1223.
- [2] Su HS, Zhang YC. Distribution grid fault location applying transient zero-mode current. *Telkomnika*. 2012; 10(5): 883-890.
- [3] Li YY. Research of carrier-pilot protection with directional comparison based on unified traveling wave. PhD Thesis. Beijing: Tsinghua University; 2005.
- [4] Borghetti A, Bosetti M, Silvestro MD, et al. Continuous-wavelet transform for fault location in distribution power networks: definition of mother wavelets inferred from fault originated transients. *IEEE Transactions on Power Systems*. 2008; 23(2): 380-388.
- [5] Tang Y, Chen H. *Selection of transmission line models for travelling-wave protection studies*. Proceedings of the CSEE. 1997; 17(4): 269-273.

- [6] Zhen W, Chen W, Chen P, et al. Simulation method and test technology of transmission line traveling wave. *Electric Power Automation Equipment*. 2011; 31(6): 74-78.
- [7] Huang WJ. Modeling and Simulation Research on Lightning Over-voltage of 500kV Hydroelectric Station. *Telkomnika*. 2012; 10(4): 619-624.
- [8] Marti JR. Accurate modeling of frequency-dependent transmission lines in electromagnetic transient simulations. *IEEE Transactions on Power Apparatus and Systems*. 1982; 101(1): 147-157.
- [9] Kocar I, Mahseredjian J, Olivier G. Improvement of numerical stability for the computation of transients in lines and cables. *IEEE Transactions on Power Delivery*. 2010; 25(2): 1104-1111.
- [10] Dong XZ, Ge YZ, Xu BY. *Research of fault location based on current travelling waves*. Proceedings of the CSEE. 1999; 19(4): 76-80.
- [11] Ji T. Study of the fault location and fault phase position selection based on traveling waves using electromagnetic voltage transformer in neutral non-effective grounding system. *Transactions of China Electrotechnical Society*. 2012; 27(8): 172-178.
- [12] Wang ZH, Yin XG, XZ Hang XB, et al. Analysis and practice of fault location by voltage traveling wave of CVT. *Automation of Electric Power Systems*. 2005; 28(22): 63-68.
- [13] Zeng XJ, Yin XG, Lin FC, et al. *Study of fault location for transmission lines based on the sensor of traveling-wave*. Proceedings of the CSEE. 2001; 22(6): 42-46.
- [14] Vermeulen HJ, Dann LR, Rooijen J Van. Equivalent circuit modelling of a capacitive voltage transformer for power system harmonic frequencies. *IEEE Transactions on Power Delivery*. 1995; 10(4): 1743-1749.
- [15] Kezunovic M, Fromen CW, Nilsson SL. Digital models of coupling capacitor voltage transformers for protective relay transient studies. *IEEE Transactions on Power Delivery*. 1992; 7(4): 1927-1935.
- [16] Annakkage UD, McLaren PG, Dirks E, et al. A current transformer model based on the Jiles-Atherton theory of ferromagnetic hysteresis. *IEEE Transactions on Power Delivery*. 2000; 15(1): 57-61.
- [17] Zeng XJ, Liu ZY, Qu MZ, et al. Simulative analysis and experimental test of the transmission characteristics of transient traveling-wave in transformer. *Journal of Changsha University of Science and Technology (Natural Science)*. 2004; 1(1): 71-75.
- [18] Wang ZJ. Transient voltage distribution and its simulation in EHV large transformer windings. PhD Thesis. Beijing: Tsinghua University; 1990.
- [19] Tang J, Sheng SL, Li J, et al. *Propagation characteristics of partial discharge pulses in transformer windings*. Proceedings of the CSEE. 2002; 22(10): 91-96.
- [20] Wu ML, Cui X. *Modeling of wide frequency characteristic of potential transformer*. Proceedings of the CSEE. 2003; 23(10): 1-5.
- [21] Zhou C, He ZY, Luo GM. Transient simulation of electromagnetic potential transformer and analysis on its traveling wave transfer characteristics. *Power System Technology*. 2007; 31(2): 84-89.
- [22] Chu XH, Zeng XJ, Deng F, et al. *Novel PCB sensor based on Rogowski coil for transmission lines fault detection*. Power & Energy Society General Meeting (PESGM). Calgary. 2009:1-4.
- [23] Spoor D, Zhu JG. Improved single-ended traveling-wave fault-location algorithm based on experience with conventional substation transducers. *IEEE Transactions on Power Delivery*. 2006; 21(3): 1714-1720.