

---

## Wind Powered Sprinkler System

**Chin Jung Huang**

Department of Mechanical and Computer Aided Engineering, St. John's University  
No. 499, Sec. 4, Tam King Road, Tamsui District, New Taipei City 251,  
Taiwan/+886939138496/+886228010039  
e-mail: jimrong@mail.sju.edu.tw

### **Abstract**

*Due to limited energy resources, excessive emission of CO<sub>2</sub>, global warming, increase of mean temperature, serious impacts have resulted on our living environment, and thus, energy saving and carbon reduction have become urgent issues. Planting grass, flowers and trees can absorb and reduce CO<sub>2</sub>, thus meeting the requirements for energy saving and carbon reduction in environmental protection. At present, most of lawns or gardens in Taiwan are maintained by manual or traditional semiautomatic watering device. Whether the lawn needs to be watered and the amount of water to be sprinkled depends on subjective decision. When the lawn is watered without examining the moisture content of the soil beforehand, it causes waste of time, labor, water and cost. The intelligent wind powered watering system developed by this study used an electromechanical integrated design system to control the humidity probe, and used the electricity generated by natural wind power and pumping device to control the sprinkling action. This system sprinkles water by sensing the soil moisture content, and stops sprinkling automatically when the soil moisture content is enough, thus achieving the purposes of cost and energy saving.*

**Keywords:** wind energy, intelligent, sprinkler system

**Copyright © 2013 Universitas Ahmad Dahlan. All rights reserved.**

### **1. Introduction**

Due to limited energy resources, excessive emission of CO<sub>2</sub>, global warming, increase of mean temperature, serious impacts have resulted on our living environment, and thus, energy saving and carbon reduction have become urgent issues. Planting grass or flowers and trees can absorb and reduce CO<sub>2</sub>, thus meeting the requirements for energy saving and carbon reduction in environmental protection. At present, most of lawns or flower gardens in Taiwan are maintained by manual or traditional semiautomatic watering device. Whether the lawn needs to be watered and the amount of water to be sprinkled depends on subjective decision. When the lawn is watered without examining the moisture content of the soil beforehand, it causes waste of time, labor, water and cost. In view of this, it is necessary to develop a wind powered sprinkler system, which can detect the soil moisture content automatically, use the electricity generated by natural wind power, accumulate natural rainwater, sprinkles water as occasion requires, and stop sprinkling automatically when the soil moisture content is enough, thus achieving the purposes of cost and energy saving.

This wind powered sprinkler system is mainly powered by wind, it is powered by Taiwan power grid until the wind power is insufficient. It is equipped with a soil moisture content probe of automatic sensor to detect the water demand of the flowers, grass and trees planted on the lawn. It is equipped with a rainwater collecting barrel to collect rainwater. It sprinkles water when needed, and stops sprinkling automatically when the soil moisture content is enough for effective control and saving cost, water resource and energy. The comparison of this wind powered sprinkler system with traditional semiautomatic watering device is shown in Table 1.

### **2. Related Studies**

Sprinkler system is mostly used for emergency fire fighting. The watering device is powered by stable and effectively controlled electric energy. At present, the watering device is used for watering lawns or gardens, or cooling the roofs of sheet iron built workshops. The watering device is also powered by electric energy, and it is manually or semi-automatically controlled. Domestic studies on the application of wind energy mainly aim at increasing the wind

power generating efficiency [1, 2], the wind energy conversion system [3], the wind energy based storage battery charging and discharging circuit design [4], and the Research of Technology Policies for Taiwan Renewable Energy Industry [5]. Since the wind energy is unstable, there are few studies of applying wind energy to watering devices, especially the wind powered sprinkler system. Related researches of wind power application are shown in Table 2.

Table 1. Comparison between Wind Powered Sprinkler System and Semiautomatic Wind Powered Sprinkler System

Item	Semiautomatic watering device	Wind powered sprinkler system
Decision on sprinkling	Personal decision	Soil moisture content of automatic sensor
Sprinkling mode	Manual	Sprinkling if necessary, sprinkling is stopped automatically if soil moisture content is enough.
Power supply	Taiwan power grid	Mainly powered by wind, Taiwan power grid is applied if wind power is insufficient.
Water consumption	High	Low
Practicability	Moderate	High

Table 2. Related Researches of Wind Power Application

Authors	Subject	Proposed Methods	Studied Results
Hanaa T. El-Madany etc al. [6]	Optimization and Feasibility Analysis of Satellite Earth Station Power System Using Homer	This paper used HOMER software to do simulation and optimal sizing of earth station power system using. Using solar and wind energy provided a continuous electric power production to determine the optimum system operation.	PV/battery system, PV/wind/battery system and wind/battery system are compared with respect to the total net present cost (NPC) and leveled cost of energy. The total NPC of wind/battery system was still higher as compared to PV/battery system and PV/wind/battery system provided if the wind speed is low enough.
D.K. Agrawal etc al. [7]	Demand Shifting Bidding in a Hybrid System with Volatile Wind Power Generation	This paper proposed a formulation of social welfare equation with price responsive demand shifting bidding and economic emission dispatch with emphasis on integration of wind power.	The example on IEEE 30 bus system generator data showed the effectiveness of the proposed model. The proposed algorithm can be used for the operation planning in the day-ahead as well as the long term planning of wind units in a constrained thermal power system.
Yingchao Zhang etc al. [8]	Performance Analysis of Doubly Excited Brushless Generator with Outer Rotor for Wind Power Application	This paper discussed variable speed constant frequency (VSCF) wind power generation, combined with the characteristic of radial laminated barrier doubly excited brushless generator (DEBG), focuses on the design and performance verification of a DEBG with outer rotor(1.5MW/600rpm) for wind power generator application.	Using finite element analysis, the magnetic fields distribution, the torque capability, EMF of winding, radial magnetic force and efficiency are investigated. All results show that the DEBG with outer rotor is potential to achieve high efficiency, low cost, low vibration and noise, enhanced reliability and flexible control for VSCF generation system applications.
Sajjad Farajianpour etc al. [9]	Improved Bacterial Foraging Algorithm for Optimum Economic Emission Dispatch with Wind Power	This paper proposed an improved bacterial foraging algorithm (IBFA) is employed to solve economic emission dispatch (EED) problem.	The results for the various weights are presented and pareto-optimal curve is drawn. This trend is achieved for both with and without wind generation system states (10% of the total load demand is supply by wind generation system).
Feng Yongxin etc al. [10]	Study of Fault Diagnosis Method for Wind Turbine with Decision Classification Algorithms and Expert System	This paper proposed a fault diagnosis method to combine the decision classification algorithms and expert system, and stated steps for data mining based on CTree, meanwhile developed the fault diagnosis system based on CLIPS.	The expert system has the advantages of high compatibility, low cost and easy to integrate with external systems. The test results showed that the misdiagnosis rate within 5%.

### 3. Methods of System Control

The wind powered sprinkler system proposed in this study uses an electromechanical integrated design system to control the soil moisture content probe, and uses the electricity generated by natural wind power and pumping device to control the sprinkling action integrally. It sprinkles water as needed by detecting the soil moisture content of flowers, grass and trees planted on the lawn. It stops sprinkling automatically if the soil moisture content is enough for effective control and saving cost, water resource and energy. The schematic diagram of the structure of the proposed system is shown in Figure 1. The wind powered sprinkler system control action is shown in Figure 2.

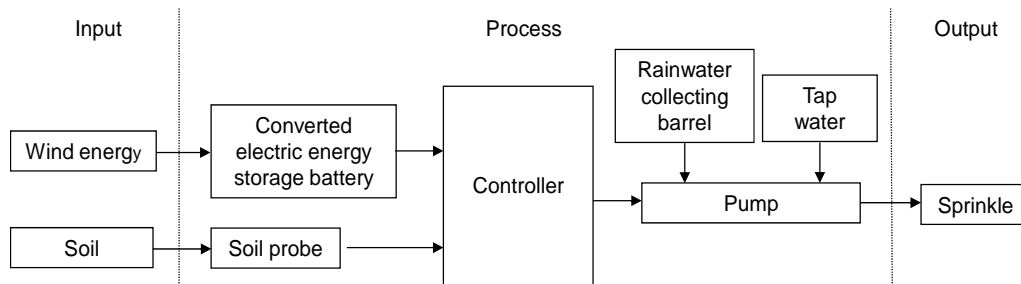

Figure 1. Schematic Diagram of Structure of Wind Powered Sprinkler System

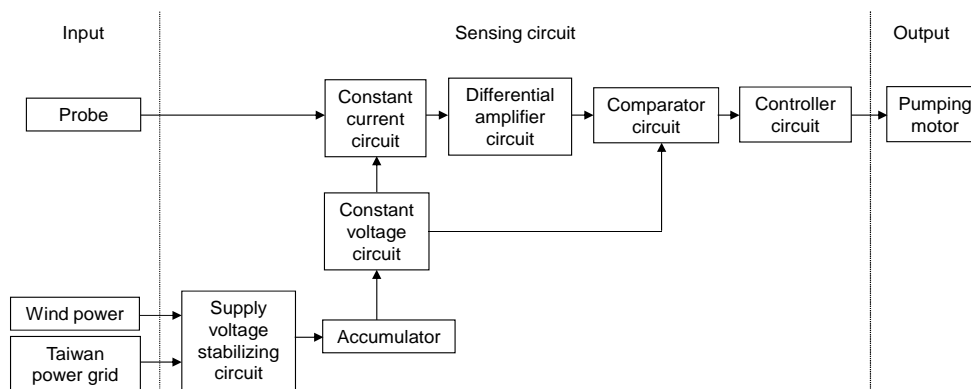

Figure 2. Wind Powered Sprinkler System Control Actuation

#### 3.1. Control Principle

The control circuit of the proposed system is designed using the most fundamental and comprehensive Ohm's Law in the circuit theory, as shown in Equation (1).

$$V = I \cdot R \quad (1)$$

I: current; R: resistance; V: voltage

According to Equation (1), if the current is a fixed value, when the resistance is high, the voltage is also high. As the conduction resistance of dry soil is higher than the conduction resistance of wet soil, the voltage is higher. When the voltage reaches the preset threshold, it is enough to drive the motor to sprinkle water. After a period of sprinkling, the dry soil turns into wet soil, the conduction resistance of wet soil decreases, and the voltage drops accordingly. Therefore, the voltage fails to reach the preset threshold, and it cannot drive the motor to sprinkle water, thus, the sprinkling action is stopped. The soil moisture content sensing actuation design is described in Table 3. The soil moisture content sensing principle is described below:

The sensors are two parallel iron rods or copper rods, and the spacing is fixed.

The probes are connected to the constant current circuit. The detection is based on  $V=i \cdot R$ .

Due to the constant current circuit, when two probes are inserted in the soil, different levels of soil humidity result in different electrical resistances, and different voltages can be obtained by changing the electrical resistance, so as to determine the soil moisture content.

Table 3. Soil Moisture Content Sensing Actuation Design

Soil type	Conduction resistance	Circuit voltage	Actuation
Very dry soil	High	High	Voltage is enough to drive motor, large sprinkling volume
Dry soil	Medium	Medium	Voltage is enough to drive motor, moderate sprinkling volume
Wet soil	Low	Low	Voltage is enough to drive motor, small sprinkling volume
Very wet soil	Zero	Zero	Under voltage fails to drive motor to sprinkle water

### 3.2. Circuit design

The power supply circuit used 9V dry battery, 7085 could convert DC above 5V into stable 5V DC, as shown in Figure 3. The constant current circuit design was based on LM385-2.5 constant voltage IC generating 2.5V, Point P could obtain constant voltage. The two probes were connected to P and G points. When the soil humidity changed, the electrical resistance between two probes changed accordingly, as shown in Figure 4. The soil moisture content sensing circuit design is shown in Figure 5. In terms of the difference amplifier circuit design, the initial value was subtracted from the voltage obtained by the probe, and the result was amplified 3.3 times to obtain the voltages in different soils, as shown in Figure 6. Finally, the analog voltage was converted by ADC0804 and fed in 8051, and displayed on LCD. The finished circuit is as shown in Figure 7.

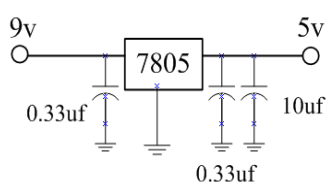

Figure 3. Circuit of Power Supply

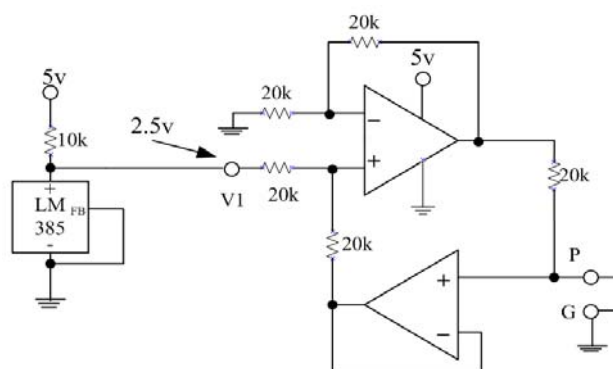

Figure 4. Constant Current Circuit Design

### 3.3. Mechanism Design

This blade mechanism starts up when the wind force is of light air (0.3 m/s-1.5m/s). When the wind force is of light breeze (1.6 m/s-3.3m/s), the blade is in operation to convert wind energy into electric energy for the pumping motor to start up the watering system. The wind energy drives the blades and is converted into electric energy. The electric energy is then stored in the accumulator for sprinkling.

The blade tail adjusts the windward side automatically with the wind direction, so as to maximize the efficiency of converting wind energy into electric energy. When the accumulator is fully charged, the electric energy converted from wind energy is discharged automatically for the LED. When the wind force is too large, the tail is adjusted to 45° windward side automatically to avoid the overload damaging the blade.

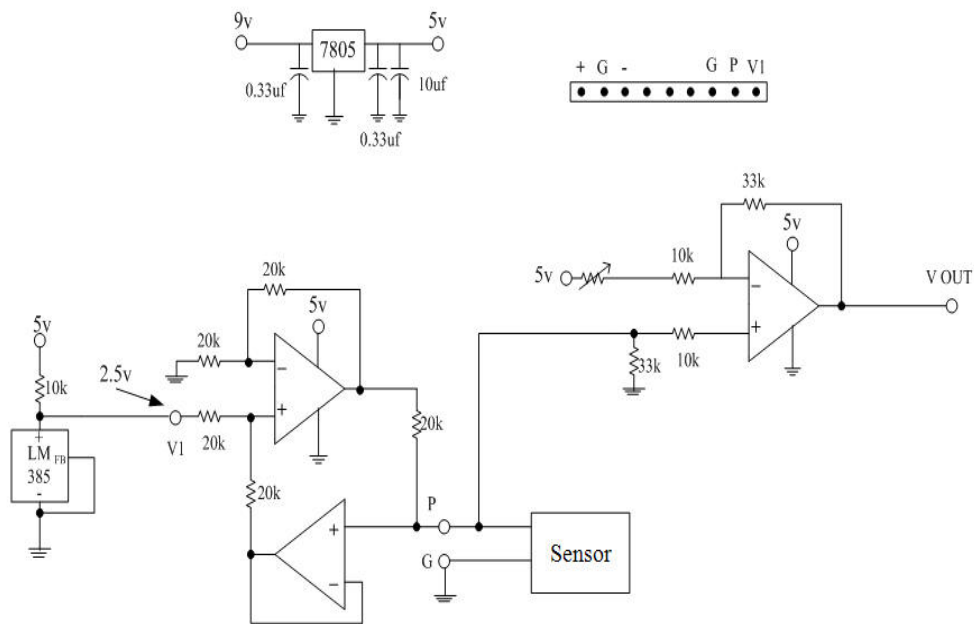

Figure 5. Soil Moisture Content Sensing Circuit

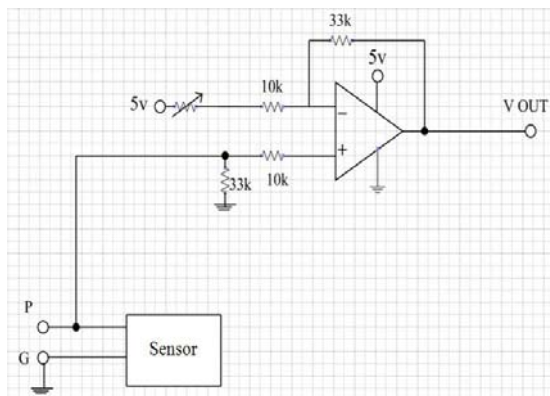

Figure 6. Difference Amplifier Circuit

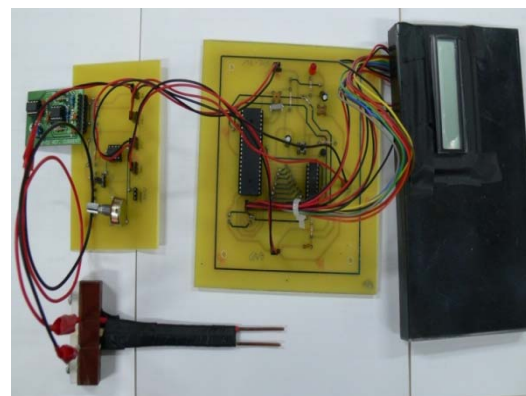

Figure 7. Finished Circuit

### 3.4. Implementation and Test

This study implemented the wind powered sprinkler system to test its function according to the control circuit and mechanism design. Three tests were conducted. The results showed that the system could convert wind energy into electric energy for the pumping motor to start up the watering device when the human face could sense a breeze about light breeze scale (1.6 m/s-3.3 m/s). The actual system is shown in Figure 8. The system was tested on the lawn in a campus. There were one dry soil area and one wet soil area (watered in advance). The electrical conductivity probe was inserted in the wet soil area, and the sprinkler was not actuated. When the electrical conductivity probe was taken out and inserted in the dry soil area, the motor was driven smoothly to sprinkle water, and the sprinkling was stopped automatically about 4 minutes later. The electrical conductivity probe was inserted in the original wet soil area, the sprinkler was not actuated. The test results met the actuation control requirement, as shown in Figure 9.

The electrical conductivity probe was inserted in the dish garden barrels with different soil moisture contents. When the soil moisture content was high, the sprinkler was not actuated.

When the soil moisture content was moderate, the motor drove sprinkling on the dish garden barrel for about 3 minutes. When the soil moisture content was low, the dish garden barrel was sprinkled with water for about five minutes before the sprinkling was stopped automatically. In order to control the soil moisture content, the resistance varied with the soil moisture content; thus, the resistance indicated soil moisture content was designed. The test of resistance indicated soil moisture content is shown in Figure 10.



Figure 8. Embodiment of Wind Powered Sprinkler System



Figure 9. Test of Wind Powered Sprinkler System on Campus Lawn



Figure 10. Test of Resistance Indicated Soil Moisture Content

#### 4. Conclusion

The conclusions of this study are as follows.

- (1) The proposed wind powered sprinkler system uses the electric energy converted from natural wind energy and natural rainfall. The automatic sensor detects the soil moisture content to determine whether to start up the sprinkler system and the sprinkling duration automatically, sprinkling if necessary, and the sprinkling is stopped automatically when the soil moisture content is enough. The electricity generated by natural wind power and natural rainfall are used. The natural resources are used efficiently.
- (2) The blade tail adjusts the windward side automatically with the wind direction, so as to maximize the efficiency of converting wind energy into electric energy. When the wind force is too large, the tail is adjusted to 45° windward side automatically to avoid the overload damaging the blade.
- (3) The proposed system has simple control circuit and low production cost. This system has been patented by the Taiwan Intellectual Property Office. Patent Number: M397693. February 11, 2011.

**References**

- [1] Chao JY. A Study of Increasing Wind Power Generating Efficiency. Master's thesis. Da-Yeh University, Changhua, Taiwan; 2008.
- [2] Chen JH. A Study of Design of Blades Efficiently Extracting Wind Energy for Vertical Axis Wind Power Generation System. Master's thesis. Mingdao University, Chiayi, Taiwan; 2005.
- [3] Chen KS. A Study of Optimal Capacitor for Power Distribution Feeder and Wind Energy Conversion System Planning. Master's thesis. Southern Taiwan University of Science and Technology, Tainan, Taiwan; 2006.
- [4] Cheng TJ. Design of Wind Energy Based Storage Battery Charging and Discharging Circuit. Master's thesis. National Chiao Tung University, Hsinchu, Taiwan; 1997.
- [5] Kuo CC. The Research of Technology Policies for Taiwan Renewable Energy Industry. Master's thesis. National Changhua University of Education, Changhua, Taiwan; 2005.
- [6] Hanaa T El-Madany, Faten H Fahmy, Ninet MA, El-Rahman, Hassen TDorrah. Optimization and Feasibility Analysis of Satellite Earth Station Power System Using Homer. *TELKOMNIKA Indonesia Journal of Electrical Engineering*. 2012; 10(2): 359-370.
- [7] DK Agrawal, NP Patidar, RK Nema. Demand Shifting Bidding in a Hybrid System with Volatile Wind Power Generation. *TELKOMNIKA Indonesia Journal of Electrical Engineering*. 2012; 10(1): 33-42.
- [8] Yingchao Zhang, Huijuan Liu, Haijiao Zhang, Xiang Zhao. Performance Analysis of Doubly Excited Brushless Generator with Outer Rotor for Wind Power Application. *TELKOMNIKA Indonesia Journal of Electrical Engineering*. 2012; 10(3): 471-476.
- [9] Sajjad Farajianpour, Ali Mohammadi, Saeed Tavakoli, S Masoud Barakati. Improved Bacterial Foraging Algorithm for Optimum Economic Emission Dispatch with Wind Power. *TELKOMNIKA Indonesia Journal of Electrical Engineering*. 2012; 10(4): 640-648.
- [10] Feng Yongxin, Yang Tao, Yang Wenguang, Jiang Dongxiang. Study of Fault Diagnosis Method for Wind Turbine with Decision Classification Algorithms and Expert System. *TELKOMNIKA Indonesia Journal of Electrical Engineering*. 2012; 10(5): 905-910.